

**INSTALLATION, OPERATION,
AND MAINTENANCE MANUAL**
WITH PARTS LIST



10 SERIES PUMP

MODEL
12B64-B

GORMAN-RUPP PUMPS

www.grpumps.com

Register your new
Gorman-Rupp pump online at
www.grpumps.com/register.

Valid serial number and e-mail address required.

RECORD YOUR PUMP MODEL AND SERIAL NUMBER

Please record your pump model and serial number in the spaces provided below. Your Gorman-Rupp distributor needs this information when you require parts or service.

Pump Model: _____

Serial Number: _____

TABLE OF CONTENTS

INTRODUCTION	PAGE I – 1
SAFETY - SECTION A	PAGE A – 1
INSTALLATION – SECTION B	PAGE B – 1
Pump Dimensions	PAGE B – 1
PREINSTALLATION INSPECTION	PAGE B – 1
POSITIONING PUMP	PAGE B – 2
Lifting	PAGE B – 2
Mounting	PAGE B – 2
Clearance	PAGE B – 2
SUCTION AND DISCHARGE PIPING	PAGE B – 2
Materials	PAGE B – 2
Line Configuration	PAGE B – 2
Connections to Pump	PAGE B – 2
Gauges	PAGE B – 3
SUCTION LINES	PAGE B – 3
Fittings	PAGE B – 3
Strainers	PAGE B – 3
Sealing	PAGE B – 3
Suction Lines In Sumps	PAGE B – 3
Suction Line Positioning	PAGE B – 3
DISCHARGE LINES	PAGE B – 4
Siphoning	PAGE B – 4
Valves	PAGE B – 4
Bypass Lines	PAGE B – 4
AUTOMATIC AIR RELEASE VALVE	PAGE B – 5
ALIGNMENT	PAGE B – 6
Coupled Drives	PAGE B – 6
V-Belt Drives	PAGE B – 7
OPERATION – SECTION C	PAGE C – 1
PRIMING	PAGE C – 1
STARTING	PAGE C – 1
Rotation	PAGE C – 1
OPERATION	PAGE C – 2
Lines With a Bypass	PAGE C – 2
Lines Without a Bypass	PAGE C – 2
Leakage	PAGE C – 2
Liquid Temperature And Overheating	PAGE C – 2
Strainer Check	PAGE C – 2
Pump Vacuum Check	PAGE C – 2
STOPPING	PAGE C – 3
Cold Weather Preservation	PAGE C – 3
BEARING TEMPERATURE CHECK	PAGE C – 3
TROUBLESHOOTING – SECTION D	PAGE D – 1
PREVENTIVE MAINTENANCE	PAGE D – 3

TABLE OF CONTENTS
(continued)

PUMP MAINTENANCE AND REPAIR - SECTION E	PAGE E – 1
STANDARD PERFORMANCE CURVE	PAGE E – 1
PARTS LIST:	
Pump Model	PAGE E – 3
PUMP AND SEAL DISASSEMBLY AND REASSEMBLY	PAGE E – 4
Back Cover Removal	PAGE E – 4
Suction Check Valve Removal and Disassembly	PAGE E – 4
Pump Casing Removal	PAGE E – 5
Impeller Removal	PAGE E – 5
Seal Removal and Disassembly	PAGE E – 5
Shaft and Bearing Removal and Disassembly	PAGE E – 6
Shaft and Bearing Reassembly and Installation	PAGE E – 7
Seal Reassembly and Installation	PAGE E – 8
Impeller Installation And Adjustment	PAGE E – 9
Pump Casing Installation	PAGE E – 10
Suction Check Valve Installation	PAGE E – 10
Back Cover Installation	PAGE E – 10
Final Pump Assembly	PAGE E – 10
LUBRICATION	PAGE E – 11
Seal Assembly	PAGE E – 11
Bearings	PAGE E – 11
Power Source	PAGE E – 11

INTRODUCTION

Thank You for purchasing a Gorman-Rupp pump. **Read this manual** carefully to learn how to safely install and operate your pump. Failure to do so could result in personal injury or damage to the pump.

Because pump installations are seldom identical, this manual cannot possibly provide detailed instructions and precautions for every aspect of each specific application. Therefore, it is the responsibility of the owner/installer of the pump to ensure that applications not addressed in this manual are performed **only** after establishing that neither operator safety nor pump integrity are compromised by the installation. Pumps and related equipment **must** be installed and operated according to all national, local and industry standards.

If there are any questions regarding the pump or its application which are not covered in this manual or in other literature accompanying this unit, please contact your Gorman-Rupp distributor, or The Gorman-Rupp Company:

The Gorman-Rupp Company
P.O. Box 1217
Mansfield, Ohio 44901—1217
Phone: (419) 755—1011
 or:
Gorman-Rupp of Canada Limited
70 Burwell Road
St. Thomas, Ontario N5P 3R7
Phone: (519) 631—2870

For information or technical assistance on the power source, contact the power source manufacturer's local dealer or representative.

HAZARD AND INSTRUCTION DEFINITIONS

The following are used to alert maintenance personnel to procedures which require special attention, to those which could damage equipment, and to those which could be dangerous to personnel:



Immediate hazards which WILL result in severe personal injury or death. These instructions describe the procedure required and the injury which will result from failure to follow the procedure.



Hazards or unsafe practices which COULD result in severe personal injury or death. These instructions describe the procedure required and the injury which could result from failure to follow the procedure.



Hazards or unsafe practices which COULD result in minor personal injury or product or property damage. These instructions describe the requirements and the possible damage which could result from failure to follow the procedure.

NOTE

Instructions to aid in installation, operation, and maintenance or which clarify a procedure.

SAFETY - SECTION A

This information applies to 10 Series basic pumps. Gorman-Rupp has no control over or particular knowledge of the power source which will be used. Refer to the manual accompanying the power source before attempting to begin operation.

Because pump installations are seldom identical, this manual cannot possibly provide detailed instructions and precautions for each specific application. Therefore, it is the owner/installer's responsibility to ensure that applications not addressed in this manual are performed only after establishing that neither operator safety nor pump integrity are compromised by the installation.



Before attempting to open or service the pump:

1. Familiarize yourself with this manual.
2. Disconnect or lock out the power source to ensure that the pump will remain inoperative.
3. Allow the pump to completely cool if overheated.
4. Check the temperature before opening any covers, plates, or plugs.
5. Close the suction and discharge valves.
6. Vent the pump slowly and cautiously.
7. Drain the pump.



This pump is designed to handle corrosive liquids containing specified entrained solids, residues and slurries. Do not attempt to pump volatile or flammable liquids which may damage the pump or endanger personnel as a result of pump failure.



After the pump has been installed, make certain that the pump and all piping or hose connections are tight, properly supported and secure before operation.



Do not operate the pump against a closed discharge valve for long periods of time. If operated against a closed discharge valve, pump components will deteriorate, and the liquid could come to a boil, build pressure, and cause the pump casing to rupture or explode.



Do not remove plates, covers, gauges, pipe plugs, or fittings from an overheated pump. Vapor pressure within the pump can cause parts being disengaged to be ejected with great force. Allow the pump to cool before servicing.



Allow an over-heated pump to completely cool before servicing. Do not re-

move plates, covers, gauges, or fittings from an over-heated pump. Liquid within the pump can reach boiling temperatures, and vapor pressure within the pump can cause parts being disengaged to be ejected with great force. After the pump completely cools, drain the liquid from the pump by removing the casing drain plug. Use caution when removing the plug to prevent injury to personnel from hot liquid.



This pump is designed to pump materials which could cause serious illness or injury through direct exposure or emitted fumes. Wear protective clothing, such as rubber gloves, face mask, and rubber apron, as necessary before disassembling the pump or piping.



Overheating may produce dangerous

fumes. Use extreme caution when venting the pump, or when removing covers, plates, plugs, or fittings.



Do not operate the pump without shields and/or guards in place over the drive shafts, belts, and/or couplings, or other rotating parts. Exposed rotating parts can catch clothing, fingers, or tools, causing severe injury to personnel.



Never run this pump backwards. Be certain that rotation is correct before fully engaging the pump.

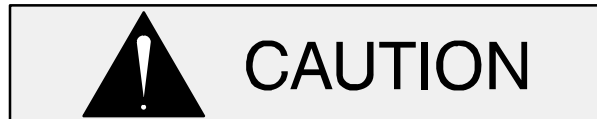

Pumps and related equipment must be installed and operated according to all national, local and industry standards.

INSTALLATION – SECTION B

Review all SAFETY information in Section A.

Since pump installations are seldom identical, this section offers only general recommendations and practices required to inspect, position, and arrange the pump and piping.

Most of the information pertains to a standard **static lift** application where the pump is positioned above the free level of liquid to be pumped.

If installed in a **flooded suction application** where the liquid is supplied to the pump under pressure, some of the information such as mounting, line configuration, and priming must be tailored to the

specific application. Since the pressure supplied to the pump is critical to performance and safety, **be sure** to limit the incoming pressure to 50% of the maximum permissible operating pressure as shown on the pump performance curve (see Section E, Page 1).

For further assistance, contact your Gorman-Rupp distributor or the Gorman-Rupp Company.

Pump Dimensions

See Figure B-1 for the approximate physical dimensions of this pump.

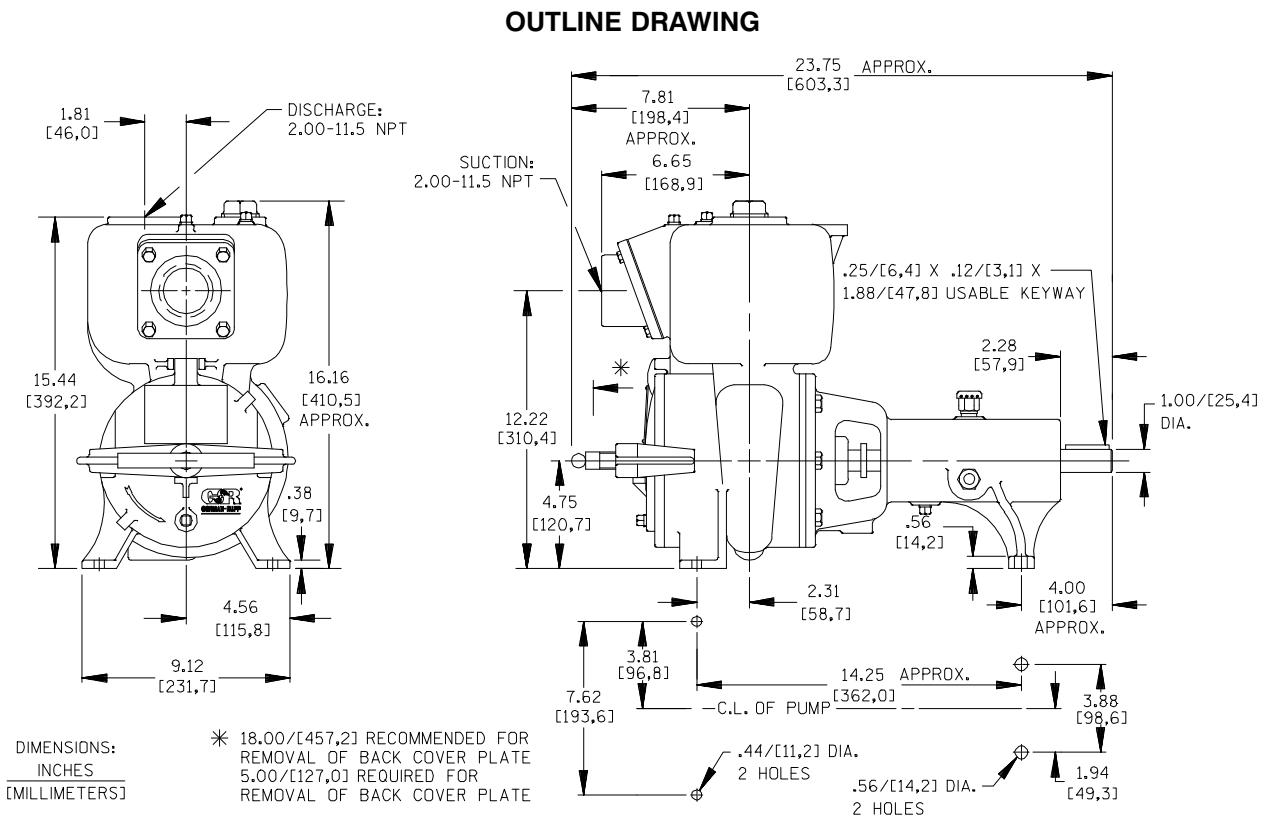

PREINSTALLATION INSPECTION

The pump assembly was inspected and tested before shipment from the factory. Before installation, inspect the pump for damage which may have occurred during shipment. Check as follows:

- a. Inspect the pump for cracks, dents, damaged threads, and other obvious damage.
- b. Check for and tighten loose attaching hardware. Since gaskets tend to shrink after drying, check for loose hardware at mating surfaces.

- c. Carefully read all tags, decals, and markings on the pump assembly, and perform all duties indicated. Note that the pump shaft rotates in the required direction.



Only operate this pump in the direction indicated by the arrow on the pump body and on the accompanying decal. Otherwise, the impeller could become loosened from the shaft and seriously damage the pump.

- d. Check levels and lubricate as necessary. Refer to **LUBRICATION** in the **MAINTENANCE AND REPAIR** section of this manual and perform duties as instructed.
- e. If the pump has been stored for more than 12 months, some of the components or lubricants may have exceeded their maximum shelf life. These **must be inspected or replaced** to ensure maximum pump service.

If the maximum shelf life has been exceeded, or if anything appears to be abnormal, contact your Gorman-Rupp distributor or the factory to determine the repair or updating policy. **Do not** put the pump into service until appropriate action has been taken.

POSITIONING PUMP

Lifting

Pump unit weights will vary depending on the mounting and drive provided. Check the shipping tag on the unit packaging for the actual weight, and use lifting equipment with appropriate capacity. Drain the pump and remove all customer-installed equipment such as suction and discharge hoses or piping before attempting to lift existing, installed units.



The pump assembly can be seriously

damaged if the chains or cables used to lift and move the unit are improperly wrapped around the pump.

Mounting

Locate the pump in an accessible place as close as practical to the liquid being pumped. Level mounting is essential for proper operation.

The pump may have to be supported or shimmed to provide for level operation or to eliminate vibration.

Clearance

A minimum clearance of **18 inches** in front of the cover plate is required to permit removal of the cover and easy access to the pump interior.

SUCTION AND DISCHARGE PIPING

Pump performance is adversely effected by increased suction lift, discharge elevation, and friction losses. See the performance curve on Page E-1 to be sure your overall application allows pump to operate within the safe operation range.

Materials

Either pipe or hose maybe used for suction and discharge lines; however, the materials must be compatible with the liquid being pumped. If hose is used in suction lines, it must be the rigid-wall, reinforced type to prevent collapse under suction. Using piping couplings in suction lines is not recommended.

Line Configuration

Keep suction and discharge lines as straight as possible to minimize friction losses. Make minimum use of elbows and fittings, which substantially increase friction loss. If elbows are necessary, use the long-radius type to minimize friction loss.

Connections to Pump

Before tightening a connecting flange, align it exactly with the pump port. Never pull a pipe line into place by tightening the flange bolts and/or couplings.

Lines near the pump must be independently supported to avoid strain on the pump which could cause excessive vibration, decreased bearing life, and increased shaft and seal wear. If hose-type lines are used, they should have adequate support to secure them when filled with liquid and under pressure.

Gauges

Most pumps are drilled and tapped for installing discharge pressure and vacuum suction gauges. If these gauges are desired for pumps that are not tapped, drill and tap the suction and discharge lines not less than 18 inches (457,2 mm) from the suction and discharge ports and install the lines. Installation closer to the pump may result in erratic readings.

SUCTION LINES

To avoid air pockets which could affect pump priming, the suction line must be as short and direct as possible. When operation involves a suction lift, the line must always slope upward to the pump from the source of the liquid being pumped; if the line slopes down to the pump at any point along the suction run, air pockets will be created.

Fittings

Suction lines should be the same size as the pump inlet. If reducers are used in suction lines, they should be the eccentric type, and should be installed with the flat part of the reducers uppermost to avoid creating air pockets. Valves are not normally used in suction lines, but if a valve is used, install it with the stem horizontal to avoid air pockets.

Strainers

If a strainer is furnished with the pump, be certain to use it; any spherical solids which pass through a strainer furnished with the pump will also pass through the pump itself.

If a strainer is not furnished with the pump, but is installed by the pump user, make certain that the total area of the openings in the strainer is at least

three or four times the cross section of the suction line, and that the openings will not permit passage of solids larger than the solids handling capability of the pump.

This pump is designed to handle up to 1-1/4 inch (31,8 mm) diameter spherical solids.

Sealing

Since even a slight leak will affect priming, head, and capacity, especially when operating with a high suction lift, all connections in the suction line should be sealed with pipe dope to ensure an airtight seal. Follow the sealant manufacturer's recommendations when selecting and applying the pipe dope. The pipe dope should be compatible with the liquid being pumped.

Suction Lines In Sumps

If a single suction line is installed in a sump, it should be positioned away from the wall of the sump at a distance equal to 1-1/2 times the diameter of the suction line.

If there is a liquid flow from an open pipe into the sump, the flow should be kept away from the suction inlet because the inflow will carry air down into the sump, and air entering the suction line will reduce pump efficiency.

If it is necessary to position inflow close to the suction inlet, install a baffle between the inflow and the suction inlet at a distance 1-1/2 times the diameter of the suction pipe. The baffle will allow entrained air to escape from the liquid before it is drawn into the suction inlet.

If two suction lines are installed in a single sump, the flow paths may interact, reducing the efficiency of one or both pumps. To avoid this, position the suction inlets so that they are separated by a distance equal to at least 3 times the diameter of the suction pipe.

Suction Line Positioning

The depth of submergence of the suction line is critical to efficient pump operation. Figure B—2 shows recommended minimum submergence vs. velocity.

NOTE

The pipe submergence required may be reduced by installing a standard pipe increaser fitting at the end of the suction line. The larger opening size will

reduce the inlet velocity. Calculate the required submergence using the following formula based on the increased opening size (area or diameter).

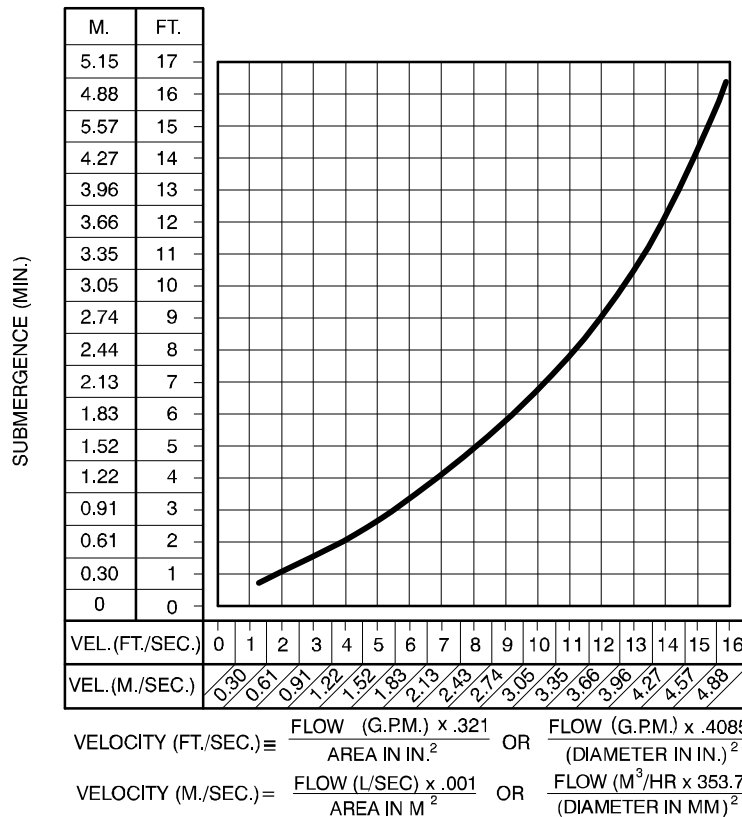

Figure B-2. Recommended Minimum Suction Line Submergence vs. Velocity

DISCHARGE LINES

Siphoning

Do not terminate the discharge line at a level lower than that of the liquid being pumped unless a siphon breaker is used in the line. Otherwise, a siphoning action causing damage to the pump could result.

Valves

If a throttling valve is desired in the discharge line, use a valve as large as the largest pipe to minimize friction losses. Never install a throttling valve in a suction line.

A check valve in the discharge line is normally recommended, but it is not necessary in low discharge head applications.

With high discharge heads, it is recommended that a throttling valve and a system check valve be installed in the discharge line to protect the pump from excessive shock pressure and reverse rotation when it is stopped.



If the application involves a high discharge head, gradually close the discharge throttling valve before stopping the pump.

Bypass Lines

Self-priming pumps are not air compressors. During the priming cycle, air from the suction line must be vented to atmosphere on the discharge side. If the discharge line is open, this air will be vented through the discharge. However, if a check valve has been installed in the discharge line, the discharge side of the pump must be opened to atmospheric pressure through a bypass line installed be-

tween the pump discharge and the check valve. A self-priming centrifugal pump **will not prime** if there is sufficient static liquid head to hold the discharge check valve closed.

NOTE

The bypass line should be sized so that it does not affect pump discharge capacity; however, the bypass line should be at least 1 inch (25,4 mm) in diameter to minimize the chance of plugging.

In **low discharge head applications** (less than 30 feet (9,1 m)), it is recommended that the bypass line be run back to the wet well, and located 6 inches below the water level or cut-off point of the low level pump. In some installations, this bypass outline may be terminated with a six-to-eight foot (1,8 to 2,4 m) length of 1-1/4 inch (31,8 mm) I.D. **smooth-bore** hose; air and liquid vented during the priming process will then agitate the hose and break up any solids, grease, or other substances likely to cause clogging.



A bypass line that is returned to a wet well must be secured against being drawn into the pump suction inlet.

It is also recommended that pipe unions be installed at each 90° elbow in a bypass line to ease disassembly and maintenance.

In **high discharge head applications** (more than 30 feet (9,1 m)), an excessive amount of liquid may be bypassed and forced back to the wet well under the full working pressure of the pump; this will reduce overall pumping efficiency. **Therefore, it is recommended that a Gorman-Rupp Automatic Air Release Valve be installed in the bypass line.**

Gorman-Rupp Automatic Air Release Valves are reliable, and require minimum maintenance. See **Automatic Air Release Valves** in this section for installation and theory of operation of the Automatic Air Release Valve. Consult your Gorman-Rupp distributor, or contact the Gorman-Rupp Company for selection of an Automatic Air Release Valve to fit your application.

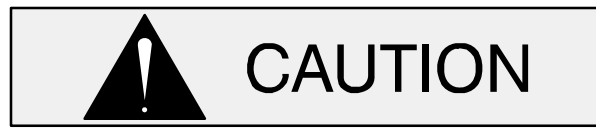

Except in certain specific applications (to prevent flooding during service of an automatic air release valve in a below-ground lift station), if a manual shut-off valve is installed **anywhere** in a bypass line, it **must** be a full-opening, **ball-type** valve to prevent plugging by solids.



A manual shut-off valve should not be installed in any bypass line. A manual shut-off valve may inadvertently be left closed during operation. A pump which has lost prime may continue to operate without reaching prime, causing dangerous overheating and possible explosive rupture of the pump casing. Personnel could be severely injured.

Allow an over-heated pump to cool before servicing. Do not remove plates, covers, gauges, or fittings from an over-heated pump. Liquid within the pump can reach boiling temperatures, and vapor pressure within the pump can cause parts being disengaged to be ejected with great force. After the pump cools, drain the liquid from the pump by removing the casing drain plug. Use caution when removing the plug to prevent injury to personnel from hot liquid.

AUTOMATIC AIR RELEASE VALVE

When properly installed, a Gorman-Rupp Automatic Air Release Valve will permit air to escape through the bypass line and then close automatically when the pump is fully primed and pumping at full capacity.



WARNING!

Some leakage (1 to 5 gallons [3.8 to 19 liters] per minute) will occur when the valve is fully closed. **Be sure the bypass line is directed back to the wet well or tank to prevent hazardous spills.**

Consult the manual accompanying the Air Release Valve for additional information on valve installation and performance.

ALIGNMENT

The alignment of the pump and its power source is critical for trouble-free mechanical operation. In either a flexible coupling or V-belt driven system, the driver and pump must be mounted so that their shafts are aligned with and parallel to each other. It is imperative that alignment be checked after the pump and piping are installed, and before operation.

NOTE

Check **Rotation**, Section C, before final alignment of the pump.

When mounted at the Gorman-Rupp factory, driver and pump are aligned before shipment. Misalignment will occur in transit and handling. Pumps **must** be checked and realigned before operation. Before checking alignment, tighten the foundation bolts. The pump casing feet and/or pedestal feet, and the driver mounting bolts should also be tightly secured.



WARNING!

When checking alignment, disconnect the power source to ensure that the pump will remain inoperative.

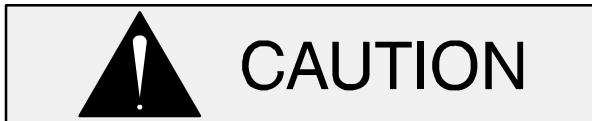

CAUTION

Adjusting the alignment in one direction may alter the alignment in another direc-

tion. Check each procedure after altering alignment.

Coupled Drives

When using couplings, the axis of the power source must be aligned to the axis of the pump shaft in both the horizontal and vertical planes. Most couplings require a specific gap or clearance between the driving and the driven shafts. Refer to the coupling manufacturer's service literature.

Align spider insert type couplings by using calipers to measure the dimensions on the circumference of the outer ends of the coupling hub every 90°. The coupling is in alignment when the hub ends are the same distance apart at all points (see Figure B-3).

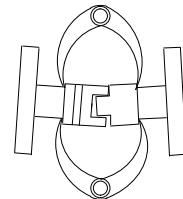

Figure B-3. Alignment of V-Belt Driven Pumps

Align non-spider type couplings by using a feeler gauge or taper gauge between the coupling halves every 90°. The coupling is in alignment when the hubs are the same distance apart at all points (see Figure B-4).

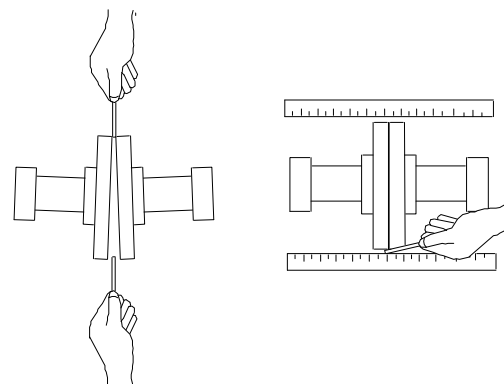

Figure B-4. Alignment of V-Belt Driven Pumps

Check parallel adjustment by laying a straightedge across both coupling rims at the top, bottom, and

side. When the straightedge rests evenly on both halves of the coupling, the coupling is in horizontal parallel alignment. If the coupling is misaligned, use a feeler gauge between the coupling and the straightedge to measure the amount of misalignment.

V-Belt Drives

When using V-belt drives, the power source and the pump must be parallel. Use a straightedge along the sides of the pulleys to ensure that the pulleys are properly aligned (see Figure B-5). In drive systems using two or more belts, make certain that the belts are a matched set; unmatched sets will cause accelerated belt wear.

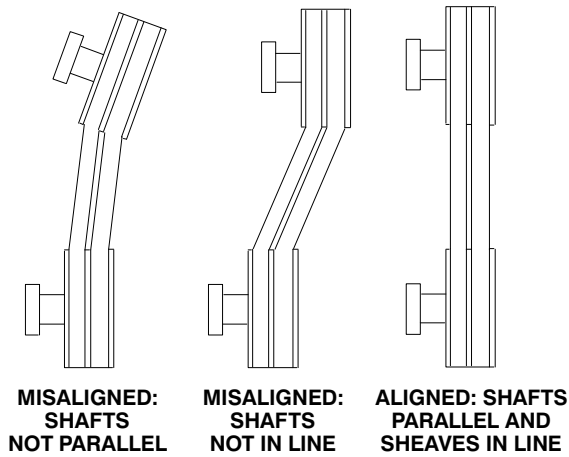

Figure B-5. Alignment of V-Belt Driven Pumps

Tighten the belts in accordance with the belt manufacturer's instructions. If the belts are too loose, they will slip; if the belts are too tight, there will be excessive power loss and possible bearing failure. Select pulleys that will match the proper speed ratio; overspeeding the pump may damage both pump and power source.



Do not operate the pump without the guard in place over the rotating parts. Exposed rotating parts can catch clothing, fingers, or tools, causing severe injury to personnel.

OPERATION – SECTION C

Review all **SAFETY** information in Section A.

Follow the instructions on all tags, labels and decals attached to the pump.



This pump is designed to handle **corrosive liquids containing specified entrained solids, residues and slurries. Do not attempt to pump volatile, or flammable liquids which may damage the pump or endanger personnel as a result of pump failure.**



Pump speed and operating condition points must be within the continuous performance range shown on the curve (see Section E, Page 1).

PRIMING

Install the pump and piping as described in **INSTALLATION**. Make sure that the piping connections are tight, and that the pump is securely mounted. Check that the pump is properly lubricated (see **LUBRICATION** in **MAINTENANCE AND REPAIR**).

This pump is self-priming, but the pump should never be operated unless there is liquid in the pump casing.



Never operate this pump unless there is liquid in the pump casing. The pump will not prime when dry. Extended operation of a dry pump will destroy the seal assembly.

Add liquid to the pump casing when:

1. The pump is being put into service for the first time.
2. The pump has not been used for a considerable length of time.
3. The liquid in the pump casing has evaporated.

Once the pump casing has been filled, the pump will prime and reprime as necessary.



After filling the pump casing, reinstall and tighten the fill plug. Do not attempt to operate the pump unless all connecting piping is securely installed. Otherwise, liquid in the pump forced out under pressure could cause injury to personnel.

To fill the pump, remove the pump casing fill cover or fill plug in the top of the casing, and add clean liquid until the casing is filled. Replace the fill cover or fill plug before operating the pump.

STARTING

Consult the operations manual furnished with the power source.

Rotation

The correct direction of pump rotation is indicated by an arrow on the pump body or accompanying decals. If the pump is operated in the wrong direction, the impeller could become loosened from the shaft and seriously damage the pump.



The pump must operate in the direction indicated by the arrow on the pump, or accompanying decals. Reverse rotation could loosen the impeller and seriously damage the pump.

Consult the operating manual furnished with the pump power source before attempting to start the power source.

If an electric motor is used to drive the pump, remove V-belts, couplings, or otherwise disconnect the pump from the motor before checking motor rotation. Operate the motor independently while observing the direction of the motor shaft, or cooling fan.

If rotation is incorrect on a three-phase motor, have a qualified electrician interchange any two of the three phase wires to change direction. If rotation is incorrect on a single-phase motor, consult the literature supplied with the motor for specific instructions.

OPERATION

Lines With a Bypass

Close the discharge throttling valve (if so equipped) so that the pump will not have to prime against the weight of the liquid in the discharge line. Air from the suction line will be discharged through the bypass line back to the wet well during the priming cycle. When the pump is fully primed and liquid is flowing steadily from the bypass line, open the discharge throttling valve. Liquid will then continue to circulate through the bypass line while the pump is in operation.

Lines Without a Bypass

Open all valves in the discharge line and start the power source. Priming is indicated by a positive reading on the discharge pressure gauge or by a quieter operation. The pump may not prime immediately because the suction line must first fill with liquid. If the pump fails to prime within five minutes, stop it and check the suction line for leaks.

After the pump has been primed, partially close the discharge line throttling valve in order to fill the line slowly and guard against excessive shock pressure which could damage pipe ends, gaskets, sprinkler heads, and any other fixtures connected to the line. When the discharge line is completely filled, adjust the throttling valve to the required flow rate.

Leakage

No leakage should be visible at pump mating surfaces, or at pump connections or fittings. Keep all line connections and fittings tight to maintain maximum pump efficiency.

Liquid Temperature And Overheating

The **maximum** liquid temperature for this pump is 160° F (71° C). Do not apply it at a higher operating temperature.

Overheating can occur if operated with the valves in the suction or discharge lines closed. Operating against closed valves could bring the liquid to a boil, build pressure, and cause the pump to rupture or explode. If overheating occurs, stop the pump and allow it to cool before servicing it. Refill the pump casing with cool liquid.



Do not remove plates, covers, gauges, pipe plugs, or fittings from an overheated pump. Vapor pressure within the pump can cause parts being disengaged to be ejected with great force. Allow the pump to cool before servicing.

Strainer Check

If a suction strainer has been shipped with the pump or installed by the user, check the strainer regularly, and clean it as necessary. The strainer should also be checked if pump flow rate begins to drop. If a vacuum suction gauge has been installed, monitor and record the readings regularly to detect strainer blockage.

Never introduce air or steam pressure into the pump casing or piping to remove a blockage. This could result in personal injury or damage to the equipment. If backflushing is absolutely necessary, **liquid pressure** must be limited to 50% of the maximum permissible operating pressure shown on the pump performance curve (see Section E, Page 1).

Pump Vacuum Check

With the pump inoperative, install a vacuum gauge in the system, using pipe dope on the threads.

Block the suction line and start the pump. At operating speed the pump should pull a vacuum of 20 inches (508,0 mm) or more of mercury. If it does not, check for air leaks in the seal, gasket, or discharge valve.

Open the suction line, and read the vacuum gauge with the pump primed and at operation speed. Shut off the pump. The vacuum gauge reading will immediately drop proportionate to static suction lift, and should then stabilize. If the vacuum reading falls off rapidly after stabilization, an air leak exists. Before checking for the source of the leak, check the point of installation of the vacuum gauge.

STOPPING

Never halt the flow of liquid suddenly. If the liquid being pumped is stopped abruptly, damaging shock waves can be transmitted to the pump and piping system. Close all connecting valves slowly.



If the application involves a high discharge head, gradually close the discharge throttling valve before stopping the pump.

After stopping the pump, disconnect the power source or lock it out to ensure that the pump will remain inoperative.

Cold Weather Preservation

In below freezing conditions, drain the pump to prevent damage from freezing. Also, clean out any solids by flushing with a hose. Operate the pump

for approximately one minute; this will remove any remaining liquid that could freeze the pump rotating parts. If the pump will be idle for more than a few hours, or if it has been pumping liquids containing a large amount of solids, drain the pump, and flush it thoroughly with clean water. To prevent large solids from clogging the drain port and preventing the pump from completely draining, insert a rod or stiff wire in the drain port, and agitate the liquid during the draining process. Clean out any remaining solids by flushing with a hose.

BEARING TEMPERATURE CHECK

Bearings normally run at higher than ambient temperatures because of heat generated by friction. Temperatures up to 160°F (71°C) are considered normal for bearings, and they can operate safely to at least 180°F (82°C).

Checking bearing temperatures by hand is inaccurate. Bearing temperatures can be measured accurately by placing a contact-type thermometer against the housing. Record this temperature for future reference.

A sudden increase in bearing temperatures is a warning that the bearings are at the point of failing to operate properly. Make certain that the bearing lubricant is of the proper viscosity and at the correct level (see **LUBRICATION** in Section E). Bearing overheating can also be caused by shaft misalignment and/or excessive vibration.

When pumps are first started, the bearings may seem to run at temperatures above normal. Continued operation should bring the temperatures down to normal levels.

TROUBLESHOOTING – SECTION D

Review all SAFETY information in Section A.



Before attempting to open or service the pump:

1. Familiarize yourself with this manual.
2. Disconnect or lock out the power source to ensure that the pump will remain inoperative.
3. Allow the pump to completely cool if overheated.
4. Check the temperature before opening any covers, plates, or plugs.
5. Close the suction and discharge valves.
6. Vent the pump slowly and cautiously.
7. Drain the pump.

TROUBLE	POSSIBLE CAUSE	PROBABLE REMEDY
PUMP FAILS TO PRIME	Not enough liquid in casing. Suction check valve contaminated or damaged. Air leak in suction line. Lining of suction hose collapsed. Leaking or worn seal or pump gasket. Suction lift or discharge head too high. Strainer clogged.	Add liquid to casing. See PRIMING . Clean or replace check valve. Correct leak. Replace suction hose. Check pump vacuum. Replace leaking or worn seal or gasket. Check piping installation and install bypass line if needed. See INSTALLATION . Check strainer and clean if necessary.
PUMP STOPS OR FAILS TO DELIVER RATED FLOW OR PRESSURE	Air leak in suction line. Lining of suction hose collapsed. Suction intake not submerged at proper level or sump too small. Impeller or other wearing parts worn or damaged.	Correct leak. Replace suction hose. Check installation and correct submergence as needed. Replace worn or damaged parts. Check that impeller is properly centered and rotates freely.

TROUBLE	POSSIBLE CAUSE	PROBABLE REMEDY
PUMP STOPS OR FAILS TO DELIVER RATED FLOW OR PRESSURE (cont.)	<p>Leaking or worn seal or pump gasket.</p> <p>Impeller clogged.</p> <p>Pump speed too slow.</p> <p>Pump running backwards.</p> <p>Suction lift or discharge head too high.</p>	<p>Check pump vacuum. Replace leaking or worn seal or gasket.</p> <p>Free impeller of debris.</p> <p>Check driver output; check belts or couplings for slippage.</p> <p>Check direction of rotation and correct by interchanging any two motor leads at control box. (See Pump Rotation, Section C).</p> <p>Check piping installation and install bypass line if needed. See INSTALLATION.</p>
PUMP REQUIRES TOO MUCH POWER	<p>Pump speed too high.</p> <p>Discharge head too low.</p> <p>Liquid solution too thick.</p>	<p>Check driver output check that sheaves or couplings are correctly sized.</p> <p>Adjust discharge valve.</p> <p>Dilute if possible.</p>
PUMP CLOGS FREQUENTLY	<p>Discharge flow too slow.</p> <p>Suction check valve or foot valve clogged or binding.</p>	<p>Open discharge valve fully to increase flow rate, and run power source at maximum governed speed.</p> <p>Clean valve.</p>
EXCESSIVE NOISE	<p>Cavitation in pump.</p> <p>Pumping entrained air.</p> <p>Pump or drive not securely mounted.</p> <p>Impeller clogged or damaged.</p>	<p>Reduce suction lift and/or friction losses in suction line. Record vacuum and pressure gauge readings and consult local representative or factory.</p> <p>Locate and eliminate source of air bubble.</p> <p>Secure mounting hardware.</p> <p>Clean out debris; replace damaged parts.</p>
BEARINGS RUN TOO HOT	<p>Bearing temperature is high, but within limits.</p> <p>Low or incorrect lubricant.</p> <p>Suction and discharge lines not properly supported.</p> <p>Drive misaligned.</p>	<p>Check bearing temperature regularly to monitor any increase.</p> <p>Check for proper type and level of lubricant.</p> <p>Check piping installation for proper support.</p> <p>Align drive properly.</p>

PREVENTIVE MAINTENANCE

Since pump applications are seldom identical, and pump wear is directly affected by such things as the abrasive qualities, pressure and temperature of the liquid being pumped, this section is intended only to provide general recommendations and practices for preventive maintenance. Regardless of the application however, following a routine preventive maintenance schedule will help assure trouble-free performance and long life from your Gorman-Rupp pump. For specific questions concerning your application, contact your Gorman-Rupp distributor or the Gorman-Rupp Company.

Record keeping is an essential component of a good preventive maintenance program. Changes in suction and discharge gauge readings (if so

equipped) between regularly scheduled inspections can indicate problems that can be corrected before system damage or catastrophic failure occurs. The appearance of wearing parts should also be documented at each inspection for comparison as well. Also, if records indicate that a certain part (such as the seal) fails at approximately the same duty cycle, the part can be checked and replaced before failure occurs, reducing unscheduled down time.

For new applications, a first inspection of wearing parts at 250 hours will give insight into the wear rate for your particular application. Subsequent inspections should be performed at the intervals shown on the chart below. Critical applications should be inspected more frequently.

Preventive Maintenance Schedule					
Item	Service Interval*				
	Daily	Weekly	Monthly	Semi-Annually	Annually
General Condition (Temperature, Unusual Noises or Vibrations, Cracks, Leaks, Loose Hardware, Etc.)	I				
Pump Performance (Gauges, Speed, Flow)	I				
Bearing Lubrication		I			R
Seal Lubrication (And Packing Adjustment, If So Equipped)		I			R
V-Belts (If So Equipped)			I		
Air Release Valve Plunger Rod (If So Equipped)			I	C	
Front Impeller Clearance (Wear Plate)				I	
Rear Impeller Clearance (Seal Plate)				I	
Check Valve					I
Pressure Relief Valve (If So Equipped)					C
Pump and Driver Alignment					I
Shaft Deflection					I
Bearings					I
Bearing Housing					I
Piping					I
Driver Lubrication – See Mfgr’s Literature					I

Legend:
 I = Inspect, Clean, Adjust, Repair or Replace as Necessary
 C = Clean
 R = Replace

* Service interval based on an intermittent duty cycle equal to approximately 4000 hours annually. Adjust schedule as required for lower or higher duty cycles or extreme operating conditions.

PUMP MAINTENANCE AND REPAIR - SECTION E

MAINTENANCE AND REPAIR OF THE WEARING PARTS OF THE PUMP WILL MAINTAIN PEAK OPERATING PERFORMANCE.

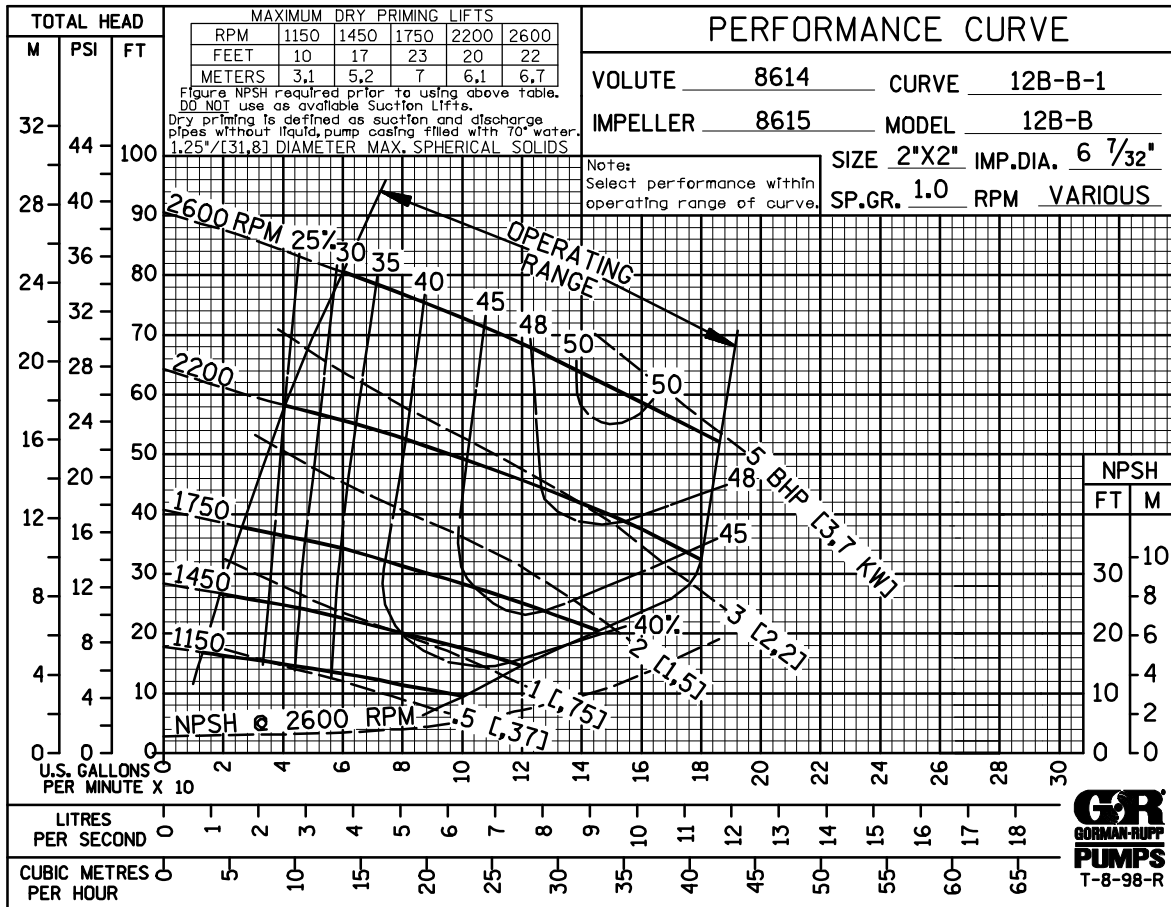

*** STANDARD PERFORMANCE FOR PUMP MODEL 12B64-B**

* Based on 70° F (21° C) clear water at sea level with minimum suction lift. Since pump installations are seldom identical, your performance may be different due to such factors as viscosity, specific gravity, elevation, temperature, and impeller trim.

Contact the Gorman-Rupp Company to verify performance or part numbers.



If your pump serial number is followed by an "N", your pump is **NOT** a standard production model.

Pump speed and operating condition points must be within the continuous performance range shown on the curve.

SECTION DRAWING

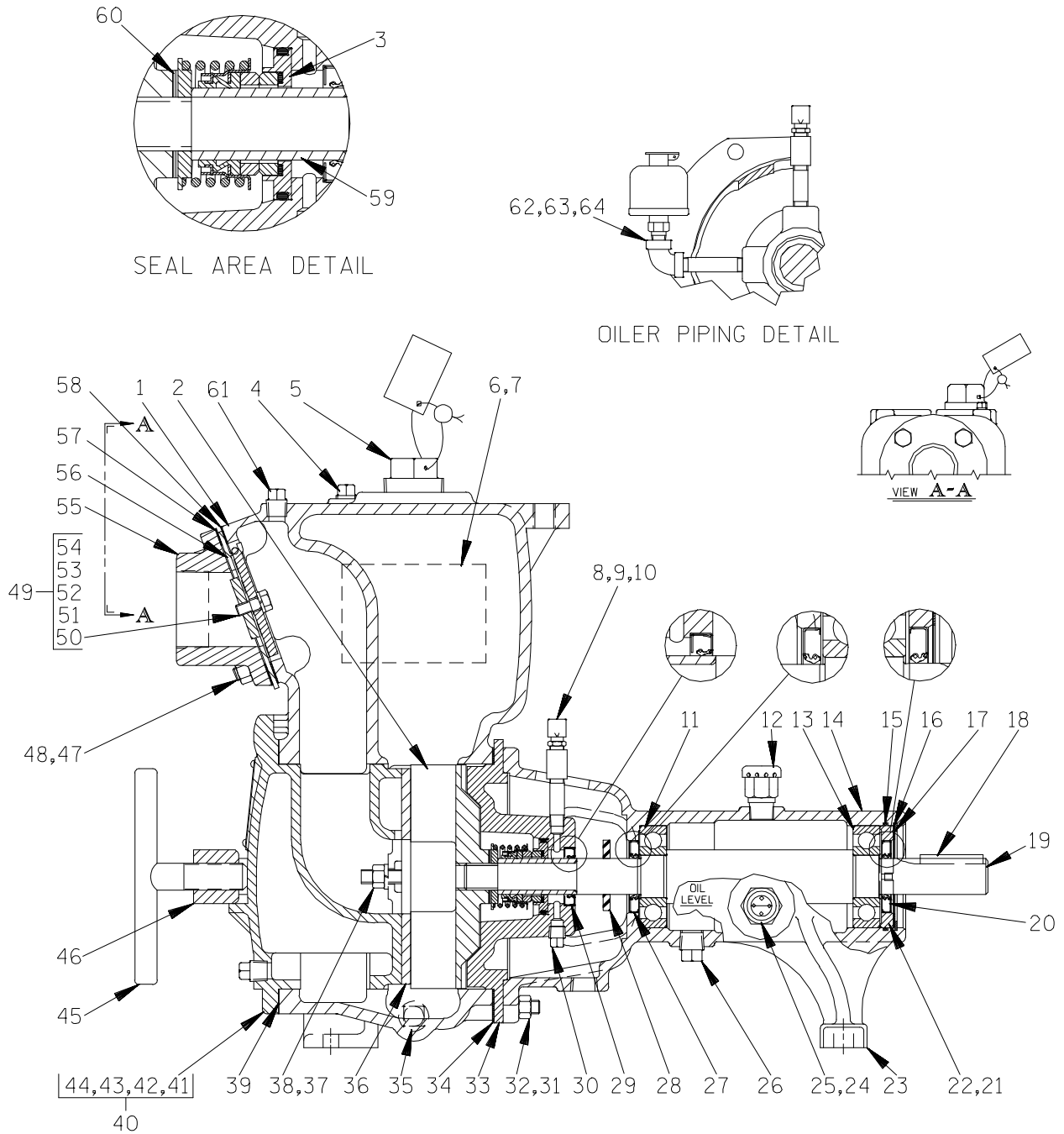

Figure E-1. Pump Model 12B64-B

PARTS LIST
Pump Model 12B64-B
 (From S/N 1373729 Up)

If your pump serial number is followed by an "N", your pump is **NOT** a standard production model. Contact the Gorman-Rupp Company to verify part numbers.

ITEM NO.	PART NAME	PART NUMBER	MAT'L CODE	QTY	ITEM NO.	PART NAME	PART NUMBER	MAT'L CODE	QTY
1	PUMP CASING	8614	17180	1	43	-WARNING PLATE	2613EV	17090	1
2 *	IMPELLER	8615	1718H	1	44	-DRIVE SCREW	BM#04-03	17000	4
3 *	SEAL ASSY	13294A	----	1	45	CLAMP BAR ASSY	8618	24000	1
4	PIPE PLUG	P04	17090	1	46	CLAMP BAR	8617	11010	1
5	FILL PLUG ASSY	48271-094	----	1	47	STUD	C0606-1/2	17090	4
6	NAME PLATE	38818-021	17010	1	48	HEX NUT	D06	17090	4
7	DRIVE SCREW	BM#04-03	17000	4	49	FLAP VALVE ASSY	9849B	----	1
8	PIPE NIPPLE	T0206	15079	1	50	-SMALL VALVE WT	9848	17090	1
9	PIPE COUPLING	AE02	15079	1	51	-HEX HD CAPSCREW	B0503	17090	1
10	AIR VENT	S1530	----	1	52	-LOCK WASHER	J05	17090	1
11 *	BALL BEARING	S390	----	1	53 *	-FLAP VALVE GASKET	9847G	19540	1
12	AIR VENT	S1730	----	1	54	-LARGE VALVE WT	9847	17190	1
13 *	BALL BEARING	S390	----	1	55	SUCTION FLANGE	1361	17070	1
14	ROTATION DECAL	2613M	----	1	56	FLAP VALVE SEAT	9846	17190	1
15 *	O-RING	26152-149	----	1	57 *	FLAP VALVE GASKET	9846G	19370	1
16	BEARING ADJ SHIM SET	5464	----	1	58 *	FLAP VALVE GASKET	9846G	19370	1
17	RETAINING RING	S219	----	1	59	SHAFT SLEEVE	4024	17090	1
18 *	SHAFT KEY	N0407	15990	1	60	IMP ADJ SHIM SET	2Y	17090	REF
19 *	IMPELLER SHAFT	38514-212	1706H	1	61	PIPE PLUG	P04	17090	1
20 *	OIL SEAL	25227-216	----	1	62	BOTTLE OILER	S1933	----	1
21	BEARING RETAINER	38322-517	26000	1	63	ELBOW	R02	11999	1
22	ALLEN HD SETSCREW	GA#10-01S	15990	2	64	PIPE NIPPLE	T0208	15079	1
23	PEDESTAL	3212C	10010	1	NOT SHOWN:				
24	SIGHT GAUGE	26714-011	----	1		INSTRUCTION LABEL	2613GK	----	1
25	PIPE PLUG	P06	15079	1		LUBE DECAL	38816-079	----	1
26	PEDESTAL DRAIN PLUG	P06	15079	1		SUCTION STICKER	6588AG	----	1
27 *	OIL SEAL	25227-216	----	1		PRIMING STICKER	6588AH	----	1
28	SLINGER RING	S351	19120	1		DISCHARGE STICKER	6588BJ	----	1
29 *	OIL SEAL	S1912	----	1		G-R DECAL	GR-03	----	1
30	PIPE PLUG	P02	15079	1		INSTRUCTION TAG	38817-011	----	1
31	STUD	C0607	17090	6		INSTRUCTION TAG	38817-012	----	1
32	HEX NUT	D06	17090	6	OPTIONAL:				
33	SEAL PLATE	38272-225	17070	1	CASING HEATER:				
34 *	CASING GASKET SET	229G	19410	1		-120V	47811-032	----	1
35	CASING DRAIN PLUG	P08	17090	1		-240V	47811-033	----	1
36 *	WEAR PLATE ASSY	9852	1718H	1	HI TEMP SHUT-DOWN KITS:				
37	HEX NUT	D06	17090	2		-145° F	48313-186	----	1
38	LOCK WASHER	J06	17090	2		-130° F	48313-256	----	1
39	BACK COVER GASKET	8616G	19370	1		-120° F	48313-257	----	1
40	BACK COVER ASSY	42111-950	----	1		HIGH TEMP SHUT-DOWN THERMOSTAT KIT:			
41	-BACK COVER	NOT AVAILABLE		1		-145° F	48313-172	----	1
42	-PIPE PLUG	P04	17090	1					

* INDICATES PARTS RECOMMENDED FOR STOCK

PUMP AND SEAL DISASSEMBLY AND REASSEMBLY

Review all SAFETY information in Section A.

Follow the instructions on all tags, label and decals attached to the pump.

This pump requires little service due to its rugged, minimum-maintenance design. However, if it becomes necessary to inspect or replace the wearing parts, follow these instructions which are keyed to the sectional view (see Figure 1) and the accompanying parts list.

This manual will alert personnel to known procedures which require special attention, to those which could damage equipment, and to those which could be dangerous to personnel. However, this manual cannot possibly anticipate and provide detailed precautions for every situation that might occur during maintenance of the unit. Therefore, it is the responsibility of the owner/maintenance personnel to ensure that **only** safe, established maintenance procedures are used, and that any procedures not addressed in this manual are performed **only** after establishing that neither personal safety nor pump integrity are compromised by such practices.

Before attempting to service the pump, disconnect or lock out the power source to ensure that the pump will remain inoperative. Close all valves in the suction and discharge lines.

For power source disassembly and repair, consult the literature supplied with the power source, or contact your local power source representative.



Before attempting to open or service the pump:

1. **Familiarize yourself with this manual.**
2. **Disconnect or lock out the power source to ensure that the pump will remain inoperative.**
3. **Allow the pump to completely cool if overheated.**

4. **Check the temperature before opening any covers, plates, or plugs.**
5. **Close the suction and discharge valves.**
6. **Vent the pump slowly and cautiously.**
7. **Drain the pump.**



This pump is designed to pump materials which could cause serious illness or injury through direct exposure or emitted fumes. Wear protective clothing, such as rubber gloves, face mask, and rubber apron, as necessary before disassembling the pump or piping.

Back Cover Removal

Before attempting to service the pump, remove the pump casing drain plug (35) and drain the pump. Clean and reinstall the drain plug.

The wear plate (36) is easily accessible and may be serviced by removing the back cover assembly (40). Loosen the clamp bar screw (45) and remove the clamp bar (46). Pull the back cover and wear plate from the pump casing. Remove the back cover gasket (39). Clean the mating surfaces of the back cover plate and pump casing.

Inspect the wear plate and replace it if badly scored or worn. To remove the wear plate, disengage the hardware (37 and 38) securing it to the back cover.

If no further disassembly is required, see **Back Cover Installation**.

Suction Check Valve Removal and Disassembly

To remove the suction check valve, reach through the back cover opening and lift the check valve assembly off the hooks on the flap valve seat (56).

Inspect the check valve parts for wear or damage. If replacement is required, remove the hardware (51 and 52) and separate the check valve gasket (53) and weights (50 and 54).

It is not necessary to remove the suction flange (55) unless replacement of the flange, gaskets (57 and 58) or check valve seat (56) is required. To remove the suction flange, remove the nuts (48). Separate the suction flange, gaskets and check valve seat from the pump casing.

If no further disassembly is required, see **Suction Check Valve Installation**.

Pump Casing Removal

To service the impeller or seal assembly, disconnect the discharge piping. Remove the hardware securing the pump to the base. Disconnect the power source.

Remove the nuts (32) and separate the pump casing and gasket set (34) from the seal plate (33) and pedestal (23). Clean the mating surfaces of the seal plate and pump casing. Tie and tag the casing gaskets, or measure and record their thickness for ease of reassembly.

Tie and tag any leveling shims used under the pump casing mounting feet to ease reassembly.

Impeller Removal

Before removing the impeller, remove the bottle oiler and piping (62, 63 and 64). Remove the seal cavity drain plug (30) and drain cavity to prevent the oil from escaping when the impeller is removed. Clean and reinstall the drain plug.

Immobilize the impeller by wedging a block wood between the vanes. If removed, install the shaft key (18). Install a lathe dog on the drive end of the shaft (19) with the “V” notch positioned over the shaft keyway.

With the impeller rotation still blocked, use a long piece of heavy bar stock to pry against the arm of the lathe dog in a counterclockwise direction (when facing the drive end of the shaft) as shown in Figure E–2. **Use caution** not to damage the shaft or keyway. When the impeller breaks loose, remove the lathe dog and wood block.

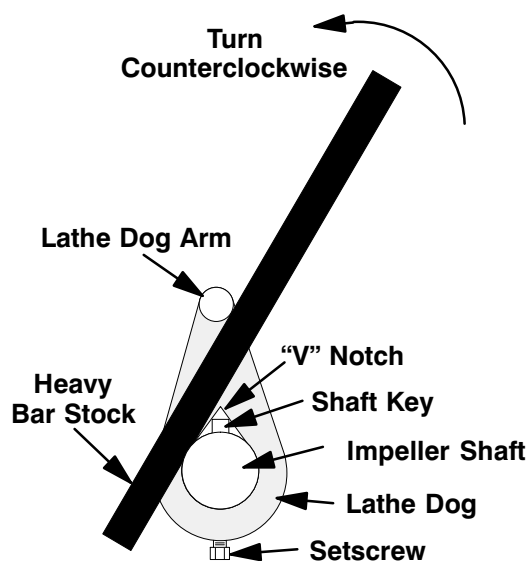

Figure E–2. Loosening Impeller

Unscrew the impeller from the shaft. Use caution when removing the impeller; tension on the seal spring will be released as the impeller is unscrewed.

Inspect the impeller and replace it if cracked or badly worn. Slide the impeller adjusting shims (60) off the impeller shaft. Tie and tag the shims or measure and record their thickness for ease of reassembly.

Seal Removal and Disassembly

Remove the spring centering washer and seal spring. Slide the shaft sleeve (59) and rotating portion of the seal off the shaft as a single unit. Apply oil to the sleeve and work it up under the bellows. Slide the rotating portion of the seal off the sleeve.

Remove the air vent and piping (8, 9 and 10) from the seal plate and slide the seal plate and stationary portion of the seal assembly off the shaft as a unit. Position the seal plate on a flat surface with the impeller side down. Use a suitably sized dowel to press the seal stationary components from the seal plate bore.

Position the seal plate on a flat surface with the impeller side up and press the oil seal (29) from the seal plate.

Inspect the seal plate and replace it if cracked or badly worn.

If no further disassembly is required, see **Seal Reassembly and Installation**.

Shaft and Bearing Removal and Disassembly

When the pump is properly operated and maintained, the pedestal should not require disassembly. Disassemble the shaft and bearings **only** when there is evidence of wear or damage.



Shaft and bearing disassembly in the field is not recommended. These operations should be performed only in a properly-equipped shop by qualified personnel.

Remove the pedestal drain plug (26) and drain the bearing lubricant. Clean and reinstall the drain plug.

Remove the slinger ring (28).

Use snap ring pliers to remove the bearing retaining ring (17) from the pedestal bore. Remove the bearing shim set (16). Tie and tag the shims or measure and record their thickness for ease of reassembly.

Remove the setscrews (22) from the bearing retainer (21) and install two 10-32 UNF by 1 inch long screws (not supplied) in the holes. Use two screwdrivers to pry against the heads of the screws to remove the bearing retainer from the pedestal bore. **Do not** use the screws as jacking screws to remove the retainer. Remove the screws from the retainer and reinstall the setscrews.

Press the oil seal (20) from the bearing retainer. Remove the bearing retainer O-ring (15) from the groove in the pedestal bore.

Place a block of wood against the impeller end of the shaft and tap the shaft and assembled bearings (11 and 13) from the pedestal. **Be careful** not to damage the shaft.

After removing the shaft and bearings, clean and inspect the bearings **in place** as follows.



To prevent damage during removal from the shaft, it is recommended that bearings be cleaned and inspected **in place**. It is **strongly** recommended that the bearings be replaced **any** time the shaft and bearings are removed.

Clean the pedestal, shaft and all component parts (except the bearings) with a soft cloth soaked in cleaning solvent. Inspect the parts for wear or damage and replace as necessary.



Most cleaning solvents are toxic and flammable. Use them only in a well ventilated area free from excessive heat, sparks, and flame. Read and follow all precautions printed on solvent containers.

Inspect the shaft for distortion, nicks or scratches, or for thread damage on the impeller end. Dress small nicks and burrs with a fine file or emery cloth. Replace the shaft if defective.

Clean the bearings thoroughly in **fresh** cleaning solvent. Dry the bearings with filtered compressed air and coat with light oil.



Bearings must be kept free of all dirt and foreign material. Failure to do so will greatly shorten bearing life. **Do not** spin dry bearings. This may scratch the balls or races and cause premature bearing failure.

Rotate the bearings by hand to check for roughness or binding and inspect the bearing balls. If rotation is rough or the bearing balls are discolored, replace the bearings.

The bearing tolerances provide a tight press fit onto the shaft and a snug slip fit into the pedestal. Replace the bearings, shaft, or pedestal if the proper bearing fit is not achieved.

If bearing replacement is required, use a bearing puller or an arbor (or hydraulic) press to remove the bearings from the shaft.

Press the inboard oil seal (27) from the pedestal bore.

Shaft and Bearing Reassembly and Installation

Clean and inspect the bearings as indicated in **Shaft and Bearing Removal and Disassembly**.



To prevent damage during removal from the shaft, it is recommended that bearings be cleaned and inspected **in place**. It is **strongly** recommended that the bearings be replaced **any** time the shaft and bearings are removed.

The bearings may be heated to ease installation. An induction heater, hot oil bath, electric oven, or hot plate may be used to heat the bearings. Bearings should **never** be heated with a direct flame or directly on a hot plate.

NOTE

*If a hot oil bath is used to heat the bearings, both the oil and the container must be **absolutely** clean. If the oil has been previously used, it must be **thoroughly** filtered.*



Use caution when handling hot bearings to prevent burns.

After the bearings have been installed and allowed to cool, check to ensure that they have not moved away from the shaft shoulders in shrinking. If movement has occurred, use a suitably sized sleeve and a press to reposition the bearings against the shaft shoulders.

If heating the bearings is not practical, use a suitably sized sleeve and an arbor (or hydraulic) press to install the bearings on the shaft.



When installing the bearings onto the shaft, **never** press or hit against the outer race, balls, or ball cage. Press **only** on the inner race.

Position the inboard oil seal (27) in the pedestal (23) with the lip positioned as shown in Figure E-1. Press the oil seal into the pedestal until the face is **just flush** with the machined surface in the pedestal.



When installing the shaft and bearings into the bearing bore, push against the outer race. **Never** hit the balls or ball cage.

Slide the shaft and assembled bearings into the pedestal until the inboard bearing seats against the pedestal bore. **Be careful** not to roll or damage the lip of the oil seal (27).

Install a new O-ring (15) in the groove in the pedestal and lubricate it with light grease.

Press the outboard oil seal (20) into the bearing retainer (21) with the lip positioned as shown in Figure E-1. Be sure the setscrews (22) are fully screwed into the bearing retainer. Position the bearing retainer in the pedestal bore with the setscrews positioned horizontally in line. **Be careful** not to damage the lip of the oil seal (20) on the shaft keyway. Press the bearing retainer into the pedestal until it is fully seated against the outboard bearing.

Install the same thickness of bearing adjusting shims (16) as previously removed. Secure the bearing retainer and shims using the bearing retaining ring (17) and check the shaft endplay.

NOTE

Shaft endplay should be between .002 and .010 inch (.05 to .25 mm). Add or remove bearing adjusting shims to achieve the correct endplay.

Slide the slinger ring (28) onto the shaft.

Lubricate the pedestal as indicated in **LUBRICATION** at the end of this section.

Seal Reassembly and Installation

Clean the seal cavity and shaft with a cloth soaked in fresh cleaning solvent.



Most cleaning solvents are toxic and flammable. Use them only in a well ventilated area free from excessive heat, sparks, and flame. Read and follow all precautions printed on solvent containers.

Inspect the impeller shaft for damage. Small scratches or nicks may be removed with a fine file or emery cloth. If excessive wear exists, the shaft will have to be replaced.

The seal is not normally reused because wear patterns on the finished faces cannot be realigned during reassembly. This could result in premature failure. If necessary to reuse an old seal in an emer-

gency, **carefully** wash all metallic parts in **fresh** cleaning solvent and allow to dry thoroughly.

Handle the seal parts with extreme care to prevent damage. Be careful not to contaminate precision finished faces; even fingerprints on the faces can shorten seal life. If necessary, clean the faces with a non-oil based solvent and a clean, lint-free tissue. Wipe **lightly** in a concentric pattern to avoid scratching the faces.

Inspect the seal components for wear, scoring, grooves, and other damage that might cause leakage. Clean and polish the shaft sleeve (61), or replace it if there are nicks or cuts on either end. If any components are worn, replace the complete seal; **never mix old and new seal parts.**

If a replacement seal is being used, remove it from the container and inspect the precision finished faces to ensure that they are free of any foreign matter.

To ease installation of the seal, lubricate the O-rings and shaft sleeve (4) with water or a very **small** amount of oil, and apply a drop of light lubricating oil on the finished faces. Assemble the seal as follows, (see Figure E-3).

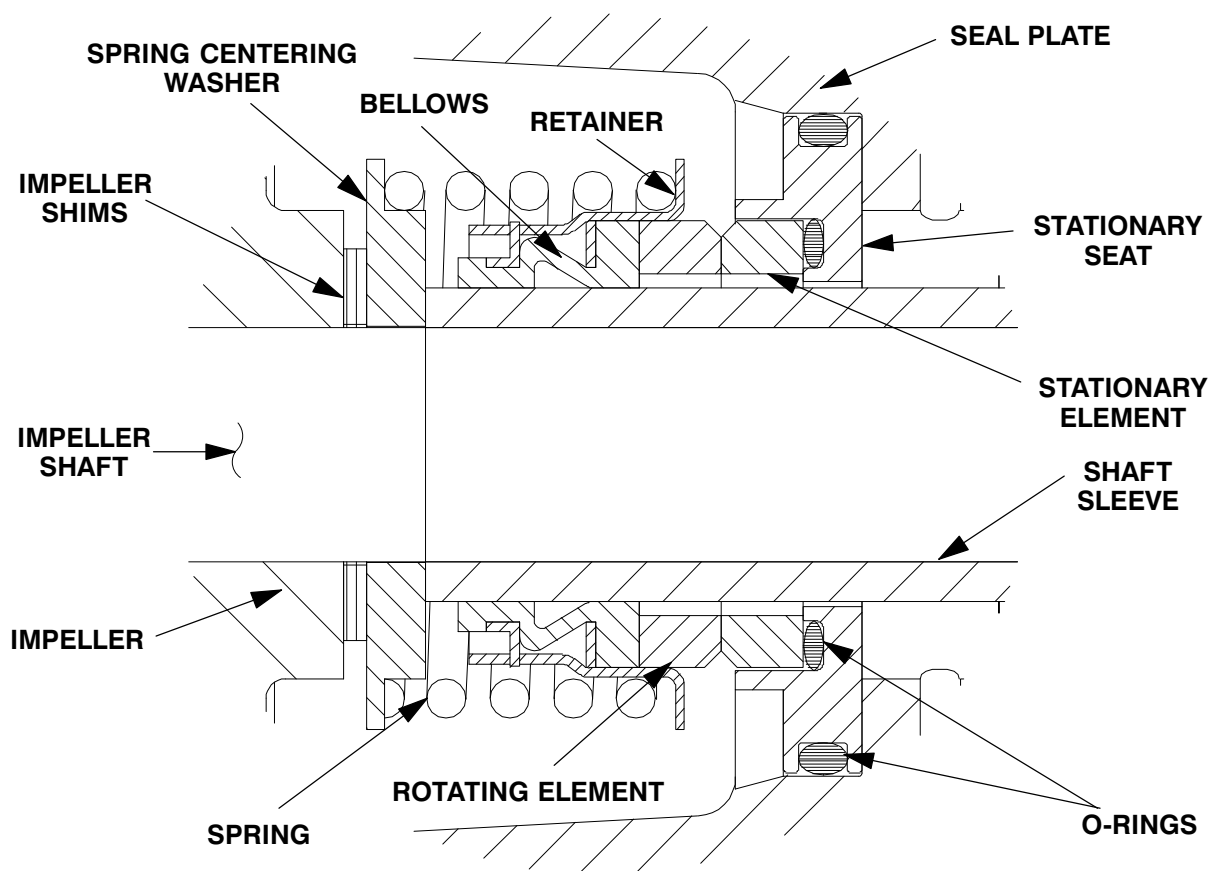

Figure E-3. Seal Assembly



This seal is not designed for operation at temperatures above 160°F (71°C). Do not use at higher operating temperatures.

Position the seal plate (33) on a flat surface with the impeller side down. Apply a light coating of oil to the oil seal (29) and press it into the seal plate with the lip positioned as shown in Figure E-1.

Position the seal plate on a flat surface with the impeller side up. Press the stationary subassembly (consisting of the stationary seat, O-rings and stationary element) into the seal plate until fully seated in the seal plate bore.

Slide the seal plate over the shaft until fully seated against the pedestal (23). **Be careful** not to damage the lip of the oil seal (29) on the shaft threads.

Align the threaded hole for the air vent (10) with the opening in the top of the pedestal and temporarily secure the seal plate using two capscrews and

nuts (3/8-16 UNC by 1-1/2 inches long, not supplied).

Lubricate the shaft sleeve (59) with light oil and slide the rotating subassembly (consisting of the rotating element, retainer and bellows) onto the sleeve until the rotating element is **just flush** with the chamfered end of the sleeve. Slide the shaft sleeve and rotating subassembly onto the shaft until the sealing faces contact. Continue to push the sleeve through the seal until it bottoms against the shaft shoulder. **Be careful** not to damage or roll the lip of the oil seal (29). Install the seal spring and spring centering washer.

Lubricate the seal assembly as indicated in **LUBRICATION**, after the impeller has been installed.

Impeller Installation And Adjustment

Inspect the impeller, and replace it if cracked or badly worn. Install the same thickness of impeller shims (60) as previously removed and screw the impeller onto the shaft until tight.

A clearance of .020 to .040 inch (0,51 to 1,02 mm) between the impeller and the seal plate is necessary for maximum pump efficiency. Measure this clearance and add or remove impeller shims until this clearance is reached.

NOTE

Be sure the seal plate is tight against the pedestal while measuring this clearance.

Install the bottle oiler and piping (62, 63 and 64).

Pump Casing Installation

Remove the hardware temporarily securing the seal plate to the pedestal. Install the same thickness of pump casing gaskets (34) as previously removed and secure the pump casing (1) to the seal plate and pedestal with the nuts (32). **Do not** fully tighten the nuts at this time.

NOTE

The back cover assembly must be in place to adjust the impeller face clearance.

A clearance of .008 to .015 inch (0,20 to 0,38 mm) between the impeller and the wear plate (36) is also recommended for maximum pump efficiency. Set this clearance by adding or removing gaskets in the pump casing gasket set (34) until the impeller scrapes against the wear plate when the shaft is turned by hand. After the impeller scrapes, add approximately .008 inch (0,20 mm) of gaskets.

After the face clearance has been set, tighten the nuts (32) securing the pump casing to the pedestal.

Suction Check Valve Installation

If the suction flange (55) was removed, install new gaskets (57 and 58) and the check valve seat (56) and secure the suction flange to the pump casing with the nuts (48).

Inspect the check valve components and replace as required. If the check valve was disassembled, assemble the check valve gasket (53) and weights (50 and 54) and secure with the hardware (50 and 51).

Reach through the back cover opening and hang the check valve on the hooks on the valve seat (56) with the large weight toward the inside of the pump casing.

Check the operation of the check valve to ensure proper seating and free movement.

Back Cover Installation

If the wear plate (36) was removed for replacement, secure it to the back cover assembly (40) using the attaching hardware (37 and 38). The wear plate must be concentric to prevent binding when the back cover assembly is installed.

Clean any scale or debris from the contacting surfaces on the pump casing that might prevent a good seal with the back cover.

NOTE

To ease future disassembly, apply a film of grease or 'Never-Seez' on the back cover shoulder, or any surface that contacts the pump casing. This action will reduce rust and scale build-up.

Replace the back cover gasket (39) and slide the back cover assembly into the pump casing.

Secure the back cover assembly by installing the clamp bar (46) and tightening the clamp bar screw (45). **Do not** over-tighten the clamp bar screw; it should be just tight enough to seal the back cover shoulder.

Check for scraping or binding between the impeller and wear plate and correct any that exists before putting the pump back into service.

Final Pump Assembly

Secure the pump to the base with the previously removed hardware. Be sure to reinstall any leveling shims used under the pump casing or pedestal mounting feet. Install the shaft key (18) and connect the power source.

Be sure the pump and power source are securely mounted to the base.

Install the suction and discharge lines and open all valves. Make certain that all piping connections are tight, properly supported and secure. Open all the valves in the suction and discharge lines.

Be sure the pump and power source have been properly lubricated, see **LUBRICATION**.

Remove the fill plug assembly (5) and fill the pump casing with clean liquid. Reinstall the fill plug and tighten it.

Refer to **OPERATION**, Section C, before putting the pump back into service.

LUBRICATION

Seal Assembly

Fill the bottle oiler (62) with SAE No. 30 non-detergent oil. Check the oil level regularly and keep the bottle oiler full.

Bearings

The pedestal was fully lubricated when shipped from the factory. Check the oil level regularly through the sight gauge (24) and maintain it at the middle of the gauge. When lubrication is required, add SAE No. 30 non-detergent oil through the hole for the air vent (10). **Do not** over-lubricate. Over-lu-

brication can cause the bearings to over-heat, resulting in premature bearing failure.

Under normal conditions, drain the pedestal once each year and refill with clean oil to the middle of the sight gauge. Change the oil more frequently if the pump is operated continuously or installed in an environment with rapid temperature change.

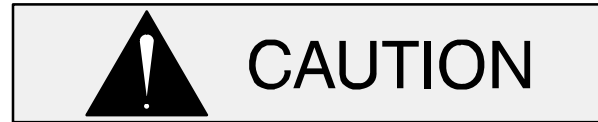

Monitor the condition of the bearing lubricant regularly for evidence of rust or moisture condensation. This is especially important in areas where variable hot and cold temperatures are common.

For cold weather operation, consult the factory or a lubricant supplier for the recommended grade of oil.

Power Source

Consult the literature supplied with the power source, or contact your local power source representative.

**For Warranty Information, Please Visit
www.grpumps.com/warranty
or call:
U.S.: 419-755-1280
Canada: 519-631-2870
International: +1-419-755-1352**

GORMAN-RUPP PUMPS