

10SERIES™

INSTALLATION, OPERATION, PARTS LIST, AND MAINTENANCE MANUAL

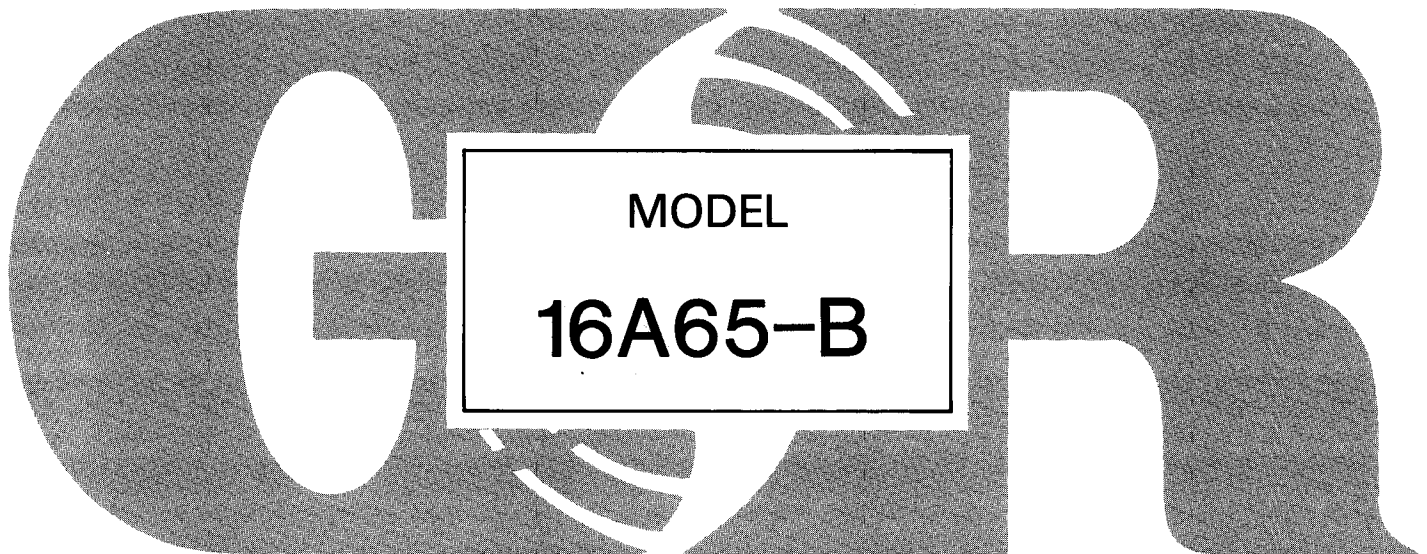

THE GORMAN-RUPP COMPANY • MANSFIELD, OHIO
GORMAN-RUPP OF CANADA LIMITED • ST. THOMAS, ONTARIO, CANADA

Printed in U.S.A.

Copyright by the Gorman-Rupp Company

TABLE OF CONTENTS

INTRODUCTION	I-1
WARNINGS - SECTION A	A-1
INSTALLATION - SECTION B	B-1
Pump Dimensions	B-1
PREINSTALLATION INSPECTION	B-2
POSITIONING PUMP	B-2
Mounting	B-2
Clearance	B-2
Lifting	B-2
SUCTION AND DISCHARGE PIPING	B-3
Materials	B-3
Line Configuration	B-3
Connections to Pump	B-3
Gauges	B-3
SUCTION LINES	B-4
Fittings	B-4
Strainers	B-4
Sealing	B-4
Suction Lines In Sumps	B-4
Suction Line Positioning	B-5
DISCHARGE LINES	B-5
Siphoning	B-5
Valves	B-6
Bypass Lines	B-6
ALIGNMENT	B-6
Coupled Drives	B-7
V-Belt Drives	B-8
OPERATION - SECTION C	C-1
PRIMING	C-1
STARTING	C-2
Rotation	C-2
OPERATION	C-2
Lines With a Bypass	C-2
Lines Without a Bypass	C-3
Leakage	C-3
Overheating	C-3
Strainer Check	C-3
Pump Vacuum Check	C-4
STOPPING	C-4
Cold Weather Preservation	C-4
BEARING TEMPERATURE CHECK	C-4
TROUBLESHOOTING - SECTION D	D-1
MAINTENANCE AND REPAIR - SECTION E	E-1
PERFORMANCE CURVE	E-1
PUMP MODEL - PARTS LIST	E-3
PUMP AND SEAL DISASSEMBLY AND REASSEMBLY	E-4
Suction Check Valve Disassembly	E-4
Pump Disassembly	E-4
Seal Disassembly	E-4
Impeller Shaft And Bearing Disassembly	E-5
Impeller Shaft And Bearing Reassembly	E-6
Seal Reassembly	E-7
Pump Reassembly	E-8
Suction Check Valve Reassembly	E-9
LUBRICATION	E-9
Seal Assembly	E-9
Bearings	E-9

INTRODUCTION

This Installation, Operation, and Maintenance Manual is designed to help you achieve the best performance and longest life from your Gorman-Rupp pump.

This pump is an 10 Series, semi-open impeller, self-priming centrifugal model designed for pumping liquids with specified entrained solids, residues, and materials that can be highly corrosive and abrasive.

If there are any questions regarding the pump which are not covered in this manual or in other literature accompanying this unit, please contact your Gorman-Rupp distributor, or write:

The Gorman-Rupp Company	or	Gorman-Rupp of Canada Limited
P.O. Box 1217		70 Burwell Road
Mansfield, Ohio 44901		St. Thomas, Ontario N5P 3R7

For information or technical assistance on the POWER SOURCE, contact the POWER SOURCE manufacturer's local dealer or representative.

The following are used to alert maintenance personnel to procedures which require special attention, to those which could damage equipment, and to those which could be dangerous to personnel:

NOTE

Instructions to aid in installation, operation, and maintenance or which clarify a procedure.

CAUTION

Instructions which must be followed to avoid causing damage to the product or other equipment incidental to the installation. These instructions describe the requirements and the possible damage which could result from failure to follow the procedures.

WARNING

```

////////////////////////////////////
//
// These instructions must be followed to avoid causing in- //
// jury or death to personnel, and describe the procedure //
// required and the injury which could result from failure //
// to follow the procedure. //
// //
////////////////////////////////////

```

WARNINGS

WARNINGS - SECTION A

THESE WARNINGS APPLY TO 10 SERIES BASIC PUMPS. GORMAN-RUPP HAS NO CONTROL OVER OR PARTICULAR KNOWLEDGE OF THE POWER SOURCE WHICH WILL BE USED. REFER TO THE MANUAL ACCOMPANYING THE POWER SOURCE BEFORE ATTEMPTING TO START THE POWER SOURCE.

WARNING

Before attempting to open or service the pump:
1. Familiarize yourself with this manual.
2. Disconnect the POWER SOURCE to ensure that the pump will remain inoperative.
3. Allow the pump to cool if overheated.
4. Vent the pump slowly and cautiously.
5. Close the suction and discharge valves.
6. Check the temperature before opening any covers, plates, or plugs.
7. Drain the pump.

WARNING

Do not attempt to pump any liquids for which this pump has not been designed.

WARNING

If this pump is used to pump volatile or corrosive fluids, wear protective safety equipment, such as goggles and rubber gloves and apron, when working on the pump.

WARNING

After the pump has been installed, make certain that the pump and all piping connections are secure before attempting to operate the pump.

WARNINGS

WARNING

```

////////////////////////////////////
//
// Do not operate the pump without shields and/or guards in //
// place over the drive shafts, belts and/or couplings, or //
// other rotating parts. Exposed rotating parts can catch //
// clothing, fingers, or tools, causing severe injury to //
// personnel. //
// //
////////////////////////////////////

```

WARNING

```

////////////////////////////////////
//
// Do not operate the pump against a closed discharge valve //
// for long periods of time. This could bring the liquid //
// to a boil, build pressure, and cause the pump to rupture //
// or explode. //
// //
////////////////////////////////////

```

WARNING

```

////////////////////////////////////
//
// Overheated pumps can cause severe burns and injury. If //
// overheating of the pump casing occurs: //
// //
// 1. Stop the pump immediately. //
// 2. Allow the pump to cool. //
// 3. Refer to instructions in this manual before re- //
// starting the pump. //
// //
////////////////////////////////////

```

WARNING

```

////////////////////////////////////
//
// Do not remove plates, covers, gauges, pipe plugs, or //
// fittings from an overheated pump. Vapor pressure within //
// the pump can cause parts being disengaged to be ejected //
// with great force. Allow the pump to cool before servic- //
// ing. //
// //
////////////////////////////////////

```

INSTALLATION - SECTION B

Seldom are two pump installations identical. The information presented in this section is a summary of the recommended installation practices related to inspection, pump positioning, hardware, suction and discharge piping, and sumps. For further assistance, contact your Gorman-Rupp distributor or the Gorman-Rupp Company.

Pump Dimensions

See Figure 1 for the approximate physical dimensions of this pump.

OUTLINE DRAWING

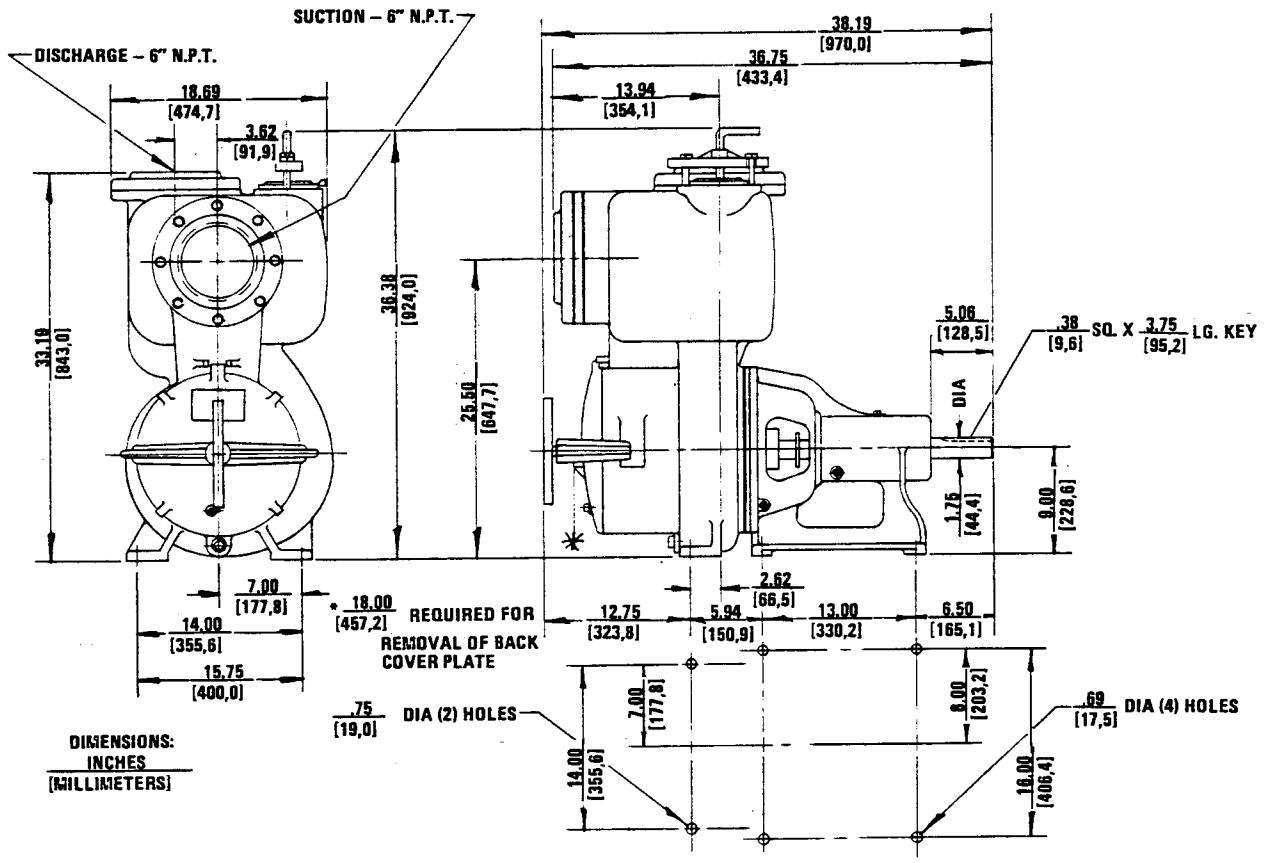

Figure 1. Pump Model 16A65-B

PREINSTALLATION INSPECTION

The pump assembly was inspected and tested before shipment from the factory. Before installation, inspect the pump for damage which may have occurred during shipment. Check as follows:

- a. Inspect the pump assembly for cracks, dents, damaged threads, and other obvious damage.
- b. Check for and tighten loose bolts, nuts, capscrews, and other attaching hardware. Since gaskets tend to shrink after drying, check for and tighten loose nuts and capscrews securing mating surfaces.
- c. Carefully read all tags, decals, and markings on the pump assembly, and perform all duties indicated. Note the direction of rotation indicated on the pump. Check that the pump shaft rotates in the required direction.

CAUTION

Only operate this pump in the direction indicated by the arrow on the pump body and on the accompanying decal. Otherwise, the impeller could become loosened from the shaft and seriously damage the pump.

- d. Check all lubricant levels and lubricate as necessary. Refer to LUBRICATION in the MAINTENANCE AND REPAIR section of this manual and perform duties as instructed.

POSITIONING PUMP

Mounting

Locate the pump in an accessible place as close as practical to the liquid being pumped. Level mounting is essential for proper operation. The pump may have to be supported or shimmed to provide for level operation or to eliminate vibration.

Clearance

A minimum clearance of **18 inches** in front of the cover plate is required to permit removal of the cover and easy access to the pump interior.

Lifting

Use lifting equipment with a capacity of at least 3500 pounds. This pump weighs approximately 660 pounds, not including the weight of accessories and base.

CAUTION

The pump assembly can be seriously damaged if the cables or chains used to lift and move the unit are improperly wrapped around the pump.

SUCTION AND DISCHARGE PIPING

Materials

Either pipe or hose may be used for suction and discharge lines. Piping materials must be compatible with the liquid being pumped. If hose is used in suction lines, it must be the rigid-wall, reinforced type to prevent collapse under suction. Using piping couplings in suction lines is not recommended.

Line Configuration

Keep suction and discharge lines as straight as possible to minimize friction losses. Make minimum use of elbows and fittings, which substantially increase friction loss. If elbows are necessary, use the long-radius type to minimize friction loss.

Connections to Pump

Before tightening a connecting flange, align it exactly with the pump port. Never pull a pipe line into place by tightening the flange bolts and/or couplings.

Lines near the pump must be independently supported to avoid strain on the pump which could cause excessive vibration, decreased bearing life, and increased shaft and seal wear. If hose-type lines are used, they should have adequate support to secure them when filled with liquid and under pressure.

Gauges

Most pumps are drilled and tapped for installing discharge pressure and vacuum suction gauges. If these gauges are desired for pumps that are not tapped, drill and tap the suction and discharge lines close to the pump before installing the lines.

SUCTION LINES

To avoid air pockets which could affect pump priming, the suction line must be as short and direct as possible. When operation involves a suction lift, the line must always slope upward to the pump from the source of the liquid being pumped; if the line slopes down to the pump at any point along the suction run, air pockets will be created.

Fittings

Suction lines should be the same size as the pump inlet. If reducers are used in suction lines, they should be the eccentric type, and should be installed with the flat part of the reducers uppermost to avoid creating air pockets. Valves are not normally used in suction lines, but if a valve is used, install it with the stem horizontal to avoid air pockets.

Strainers

If a strainer is furnished with the pump, be certain to use it; any entrained solids which pass through a strainer furnished with the pump will also pass through the pump itself.

If a strainer is not furnished with the pump, but is installed by the pump user, make certain that the total area of the openings in the strainer is at least three or four times the cross section of the suction line, and that the openings will not permit passage of solids larger than the solids handling capability of the pump.

Sealing

Since even a slight leak will affect priming, head, and capacity, especially when operating with a high suction lift, all connections in the suction line should be sealed with pipe dope to ensure an airtight seal. In volatile and/or corrosive service, the pipe dope should be compatible with the liquid being pumped.

Suction Lines In Sumps

If a single suction line is installed in a sump, it should be positioned away from the wall of the sump at a distance equal to one and one-half times the diameter of the suction line.

If there is a liquid flow from an open pipe into the sump, the flow should be kept away from the suction inlet because the inflow will carry air down into the sump, and air entering the suction line will reduce pump efficiency.

If it is necessary to position inflow close to the suction inlet, install a baffle between the inflow and the suction inlet at a distance one and one-half

times the diameter of the suction pipe. The baffle will allow entrained air to escape from the liquid before it is drawn into the suction inlet.

If two suction lines are installed in a single sump, the flow paths may interact, reducing the efficiency of one or both pumps. To avoid this, position the suction inlets so that they are separated by a distance equal to at least three times the diameter of the suction pipe.

Suction Line Positioning

The depth of submergence of the suction line is critical to efficient pump operation. Figure 2 shows recommended minimum submergence vs. velocity.

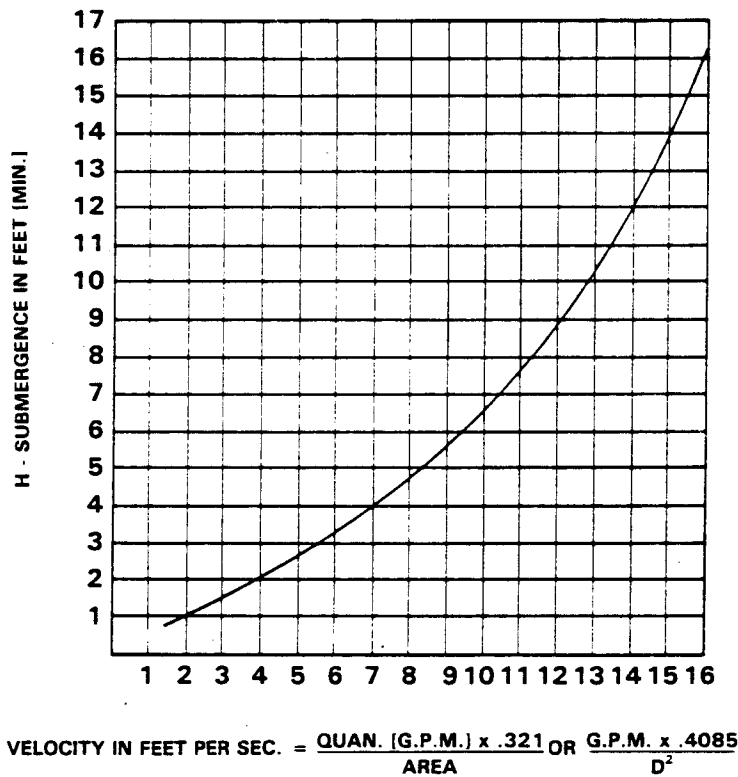

Figure 2. Recommended Minimum Suction Line Submergence Vs. Velocity

DISCHARGE LINES

Siphoning

Do not terminate the discharge line at a level lower than that of the liquid being pumped unless a siphon breaker is used in the line. Otherwise, a siphoning action causing damage to the pump could result.

INSTALLATION

Valves

If a throttling valve is desired in the discharge line, use a valve as large as the largest pipe in the line to minimize friction losses. Never install a throttling valve in a suction line.

A check valve in the discharge line is normally recommended, but is not necessary in low discharge head applications.

With high discharge heads, it is recommended that a throttling valve and a check valve be installed in the discharge line to protect the pump from excessive shock pressure and reverse rotation when it is stopped.

Bypass Lines

If it is necessary to permit the escape of air to atmosphere during initial priming or in the repriming cycle, install a bypass line between the pump and the discharge check valve. The bypass line should be sized so that it does not affect pump discharge capacity.

Either a Gorman-Rupp automatic air release valve - which will automatically open to allow the pump to prime, and automatically close when priming is accomplished - or a hand-operated shutoff valve should be installed in the bypass line.

NOTE

The bypass line may clog frequently, particularly if the valve remains closed. If this condition occurs, either use a larger bypass line or leave the shutoff valve open during the pumping operation.

Do not terminate the discharge line at a level lower than that of the liquid being pumped unless a siphon breaker is used in the line. Otherwise, a siphoning action could result, causing damage to the pump.

ALIGNMENT

The alignment of the pump and its power source is critical for trouble-free mechanical operation. In either a flexible coupling or V-belt driven system, the driver and pump must be mounted so that their shafts are aligned with and parallel to each other. It is imperative that alignment be checked after the pump is installed, and before operation.

NOTE

Check **Rotation**, Section C, before final alignment of the pump.

When mounted at the Gorman-Rupp factory, driver and pump are aligned before shipment. Misalignment can occur in transit and handling. Pumps should be checked, and realigned if necessary, before being put into operation. Before checking alignment, tighten the foundation bolts. The pump casing feet and/or pedestal feet, and the driver mounting bolts should also be tightly secured.

WARNING

```

////////////////////////////////////
//
// When checking alignment, disconnect the power source to //
// ensure that the pump will remain inoperative.           //
//
////////////////////////////////////

```

CAUTION

Adjusting the alignment in one direction may alter the alignment in another direction. Check each procedure after altering alignment.

Coupled Drives

When using couplings, the axis of the power source must be aligned to the axis of the pump shaft in both the horizontal and vertical planes. Most couplings require a specific gap or clearance between the driving and the driven shafts. Refer to the coupling manufacturer's service literature.

Align spider insert type couplings by using calipers to measure the dimensions on the circumference of the outer ends of the coupling hub every 90 degrees. The coupling is in alignment when the hub ends are the same distance apart at all points (see figure 2A).

Align non-spider type couplings by using a feeler gauge or taper gauge between the coupling halves every 90 degrees. The coupling is in alignment when the hubs are the same distance apart at all points (see figure 2B).

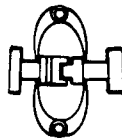

Figure 2A. Aligning Spider-Type Couplings



Figure 2B. Aligning Non-Spider Type Couplings

Check parallel adjustment by laying a straightedge across both coupling rims at the top, bottom, and side. When the straightedge rests evenly on both halves of the coupling, the coupling is in horizontal parallel alignment. If the coupling is misaligned, use a feeler gauge between the coupling and the straightedge to measure the amount of misalignment.

V-Belt Drives

When using V-belt drives, the power source and the pump must be parallel. Use a straightedge along the sides of the pulleys to ensure that the pulleys are properly aligned (see figure 2C). In drive systems using two or more belts, make certain that the belts are a matched set; unmatched sets will cause accelerated belt wear.

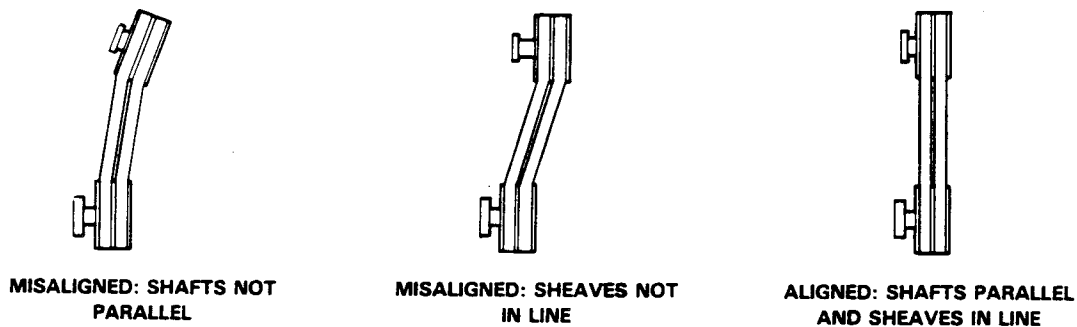

Figure 2C. Alignment of V-Belt Driven Pumps

Tighten the belts in accordance with the belt manufacturer's instructions. If the belts are too loose, they will slip; if the belts are too tight, there will be excessive power loss and possible bearing failure. Select pulleys that will match the proper speed ratio; overspeeding the pump may damage both pump and power source.



WARNING

```
////////////////////////////////////  
//  
// Do not operate the pump without a guard over the rotat- //  
// ing parts. Exposed rotating parts can catch clothing, //  
// fingers, or tools, causing severe injury to personnel. //  
//  
////////////////////////////////////
```

OPERATION

OPERATION - SECTION C

WARNING

```

////////////////////////////////////
//
// Do not attempt to pump any liquids for which this pump //
// has not been designed. //
// //
////////////////////////////////////

```

PRIMING

Install the pump and piping as described in INSTALLATION. Make sure that the piping connections are tight, and that the pump is securely mounted. Check that the pump is properly lubricated (see LUBRICATION in MAINTENANCE AND REPAIR).

This pump is self-priming, but the pump should never be operated unless there is liquid in the volute.

CAUTION

<p>Never operate a self-priming pump unless there is liquid in the volute. The pump will not prime when dry. Extended operation of a dry pump will destroy the seal assembly.</p>

Add liquid to the volute casing when:

1. The pump is being put into service for the first time.
2. The pump has not been used for a considerable length of time.
3. The liquid in the volute casing has evaporated.

Once the volute housing has been filled, the pump will prime and reprime as necessary.

WARNING

```

////////////////////////////////////
//
// After filling the volute casing, do not attempt to oper- //
// ate the pump unless all connecting piping is securely //
// installed. Otherwise, liquid in the pump forced out un- //
// der pressure could cause injury to personnel. //
// //
////////////////////////////////////

```

To fill the pump, remove the volute fill cover or fill plug at the top of the casing and add clean liquid until the pump is filled. Replace the fill cover or fill plug before operating the pump.

STARTING

Consult the operations manual furnished with the POWER SOURCE.

Rotation

The correct direction of pump rotation is indicated by an arrow on the pump body and on the accompanying decal. If the pump is operated in the wrong direction, the impeller could become loosened from the shaft and seriously damage the pump.

CAUTION

Only operate this pump in the direction indicated by the arrow on the pump body and on the accompanying decal. Otherwise, the impeller could become loosened from the shaft and seriously damage the pump.

Consult the operating manual furnished with the pump power source before attempting to start the power source.

If an electric motor is being used as a power source, remove V-belts, couplings, or otherwise disconnect the pump from the motor before checking motor rotation. Operate the motor independently, and check rotation. If incorrect, have the motor wiring checked by qualified personnel.

If a three-phase electric motor is being used, check rotation by starting the pump for a moment to see if the rotation is correct. If the shaft, coupling, or V-belt is not visible, rotation can usually be determined by observing the motor cooling fan. If the rotation is incorrect, have qualified personnel interchange any two of the three-phase wires to change direction.

OPERATION

Lines With a Bypass

Either a Gorman-Rupp automatic air release valve or a hand operated shutoff valve may be installed in a bypass line.

If a Gorman-Rupp automatic air release valve has been installed, close the throttling valve in the discharge line. The Gorman-Rupp valve will automatically open to allow the pump to prime, and automatically close when priming has been accomplished. After the pump has been primed, and liquid is flowing steadily from the bypass line, open the discharge throttling valve.

If a hand operated shutoff valve has been installed, close the throttling valve in the discharge line, and open the bypass shutoff valve so that the pump will not have to prime against the weight of the liquid in the discharge line. When

the pump has been primed, and liquid is flowing steadily from the bypass line, close the bypass shutoff valve and open the discharge throttling valve.

Lines Without a Bypass

Open all valves in the discharge line and start the power source. Priming is indicated by a positive reading on the discharge pressure gauge or by a quieter operation. The pump may not prime immediately because the suction line must first fill with liquid. If the pump fails to prime within five minutes, stop it and check the suction line for leaks.

After the pump has been primed, partially close the discharge line throttling valve in order to fill the line slowly and guard against excessive shock pressure which could damage pipe ends, gaskets, sprinkler heads, and any other fixtures connected to the line. When the discharge line is completely filled, adjust the throttling valve to the required flow rate.

Leakage

No leakage should be visible at pump mating surfaces, or at pump connections or fittings. Keep all line connections and fittings tight to maintain maximum pump efficiency.

Overheating

Overheating can occur if the valves in the suction or discharge lines are closed. Operating against closed valves could bring the liquid to a boil, build pressure, and cause the pump to rupture or explode. If overheating occurs, stop the pump and allow it to cool before servicing it. Refill the volute casing with cool liquid.

WARNING

```

////////////////////////////////////
//                               //
// Do not remove plates, covers, gauges, pipe plugs, or //
// fittings from an overheated pump. Vapor pressure within //
// the pump can cause parts being disengaged to be ejected //
// with great force. Allow the pump to cool before servic- //
// ing. //
//                               //
////////////////////////////////////

```

Strainer Check

If a suction strainer has been shipped with the pump or installed by the user, check the strainer regularly, and clean it as necessary. The strainer should also be checked if pump flow rate begins to drop.

Pump Vacuum Check

With the pump inoperative, install a vacuum gauge in the system, using pipe dope on the threads. Block the suction line and start the pump. At operating speed the pump should pull a vacuum of 20 inches or more of mercury. If it does not, check for air leaks in the seal, gasket, or discharge valve.

Open the suction line, and read the vacuum gauge with the pump primed and at operation speed. Shut off the pump. The vacuum gauge reading will immediately drop proportionate to static suction lift, and should then stabilize. If the vacuum reading falls off rapidly after stabilization, an air leak exists. Before checking for the source of the leak, check the point of installation of the vacuum gauge.

STOPPING

Never halt the flow of liquid suddenly. If the liquid being pumped is stopped abruptly, damaging shock waves can be transmitted to the pump and piping system. Close all connecting valves slowly. If the pump is driven by an engine, reduce the throttle speed slowly and allow the engine to idle for approximately two minutes before stopping.

After stopping the pump, disconnect the power source to ensure that the pump will remain inoperative.

Cold Weather Preservation

In below freezing conditions, drain the pump to prevent damage from freezing. Also, clean out any solids by flushing with a hose. Operate the pump for approximately one minute; this will remove any remaining liquid that could freeze the pump rotating parts.

If the pump will be idle for more than a few hours, or if it has been pumping liquids containing a large amount of solids, drain the pump, and flush it thoroughly with clean water. To prevent large solids from clogging the drain port and preventing the pump from completely draining, insert a rod or stiff wire in the drain port, and agitate the liquid during the draining process. Clean out any remaining solids by flushing with a hose.

BEARING TEMPERATURE CHECK

Bearings normally run at higher than ambient temperatures because of heat generated by friction. Temperatures up to 160°F are considered normal for pedestal bearings, and they can operate safely to at least 180°F.

Checking bearing temperatures by hand is inaccurate. Bearing temperatures can be measured accurately by placing a contact-type thermometer against the housing. Record this temperature for future reference.

A sudden increase in bearing temperatures is a warning that the bearings are at the point of failing to operate properly. Make certain that the bearing

OPERATION

lubricant is of the proper viscosity and at the correct level (see LUBRICATION in MAINTENANCE AND REPAIR). Bearing overheating can also be caused by shaft misalignment and/or excessive vibration.

When pumps are first started, the bearings may seem to run at temperatures above normal. Continued operation should bring the temperatures down to normal levels.

TROUBLESHOOTING - SECTION D

WARNING

```

////////////////////////////////////
// Before attempting to open or service the pump: //
// //
// 1. Familiarize yourself with this manual. //
// 2. Disconnect the POWER SOURCE to ensure that the //
// pump will remain inoperative. //
// 3. Allow the pump to cool if overheated. //
// 4. Vent the pump slowly and cautiously. //
// 5. Close the suction and discharge valves. //
// 6. Check the temperature before opening any covers, //
// plates, or plugs. //
// 7. Drain the pump. //
////////////////////////////////////
    
```

TROUBLE	POSSIBLE CAUSE	PROBABLE REMEDY
PUMP FAILS TO PRIME	Air leak in suction line.	Correct leak.
	Lining of suction hose collapsed.	Replace suction hose.
	Suction check valve clogged or binding.	Clean valve.
	Leaking or worn seal or pump gasket.	Check pump vacuum. Replace leaking or worn seal or gasket.
	Suction lift or discharge head too high.	Check piping installation and install bypass line if needed. See INSTALLATION.
	Strainer clogged.	Check strainer and clean if necessary.
PUMP STOPS OR FAILS TO DELIVER RATED FLOW OR PRESSURE	Air leak in suction line.	Correct leak.
	Suction intake not submerged at proper level or sump too small.	Check installation and correct as needed. Check submergence chart (Section B).
	Lining of suction hose collapsed.	Replace suction hose.
	Impeller or other wearing parts worn or damaged.	Replace worn or damaged parts. Check that impeller is properly centered and rotates freely.

TROUBLE	POSSIBLE CAUSE	PROBABLE REMEDY
PUMP STOPS OR FAILS TO DELIVER RATED FLOW OR PRESSURE (cont.)	<p>Impeller clogged.</p> <p>Pump speed too slow.</p> <p>Discharge head too high.</p> <p>Suction lift too high.</p> <p>Leaking or worn seal or pump gasket.</p> <p>Strainer clogged.</p>	<p>Free impeller of debris.</p> <p>Check driver output; check belts or couplings for slippage.</p> <p>Install bypass line.</p> <p>Reduce suction lift.</p> <p>Check pump vacuum. Replace leaking or worn seal or gasket.</p> <p>Check strainer and clean if necessary.</p>
PUMP REQUIRES TOO MUCH POWER	<p>Pump speed too high.</p> <p>Discharge head too low.</p> <p>Liquid solution too thick.</p>	<p>Check driver output; check that sheaves or couplings are correctly sized.</p> <p>Adjust discharge valve.</p> <p>Dilute if possible.</p>
PUMP CLOGS FREQUENTLY	<p>Discharge flow too slow.</p> <p>Suction check valve clogged or binding.</p>	<p>Open discharge valve fully to increase flow rate, and run engine at maximum governed speed.</p> <p>Clean valve.</p>
EXCESSIVE NOISE	<p>Cavitation in pump.</p> <p>Pumping entrained air.</p> <p>Pump or drive not securely mounted.</p> <p>Impeller clogged or damaged.</p>	<p>Reduce suction lift and/or friction losses in suction line.</p> <p>Locate and eliminate source of air bubble.</p> <p>Secure mounting hardware.</p> <p>Clean out debris; replace damaged parts.</p>

TROUBLE	POSSIBLE CAUSE	PROBABLE REMEDY
BEARINGS RUN TOO HOT	Bearing temperature is high, but within limits. Low or incorrect lubricant. Suction and discharge lines not properly supported. Drive misaligned.	Check bearing temperature regularly to monitor any increase. Check for proper type and level of lubricant. Check piping installation for proper support. Align drive properly.

MAINTENANCE AND REPAIR - SECTION E

MAINTENANCE AND REPAIR OF THE WEARING PARTS OF THE PUMP WILL MAINTAIN PEAK OPERATING PERFORMANCE.

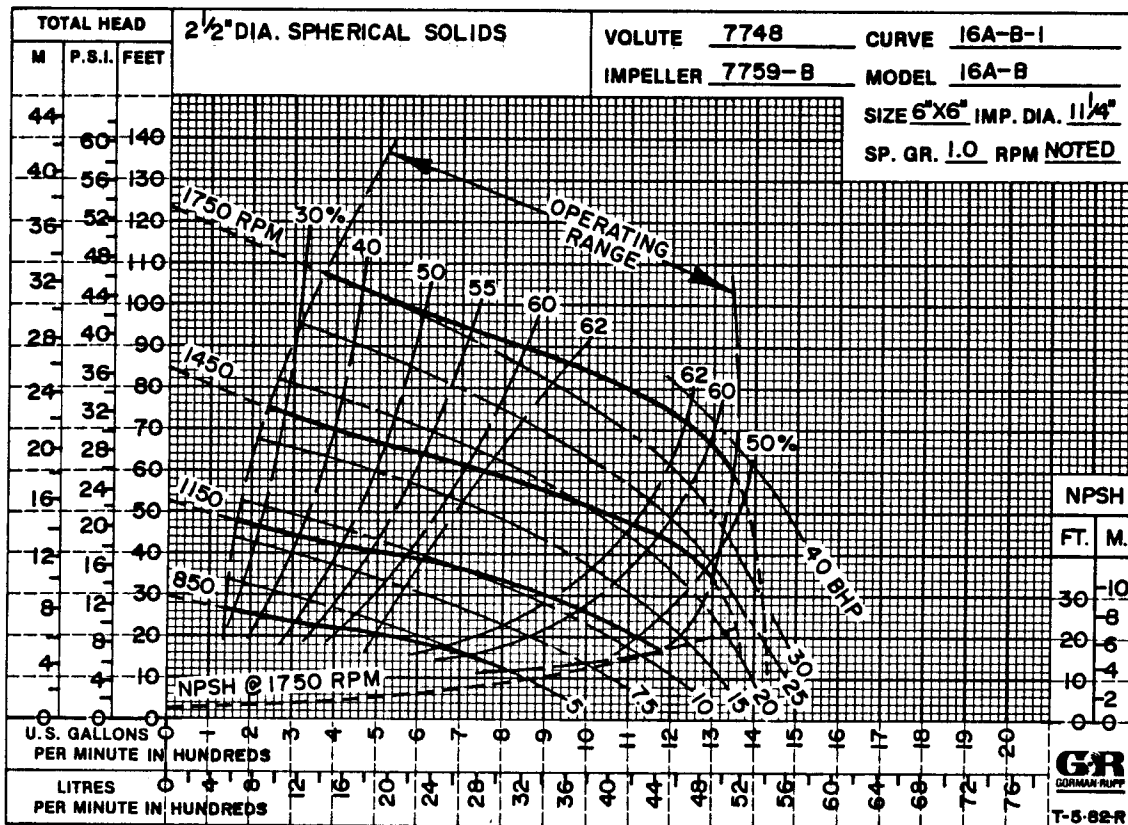

***STANDARD PERFORMANCE FOR PUMP MODEL 16A65-B**

*Based on 70°F clear water at sea level with minimum suction lift. Since pump installations are seldom identical, your performance may be different due to such factors as viscosity, specific gravity, elevation, temperature, and impeller trim.

If your pump serial number is followed by an "N", your pump is NOT a standard production model. Contact the Gorman-Rupp Company to verify performance or part numbers.

PARTS LIST
PUMP MODEL 16A65-B
 (From S/N 776101 up)

ITEM NO.	PART NAME	PART NUMBER	MATL CODE	QTY	ITEM NO.	PART NAME	PART NUMBER	MATL CODE	QTY
1	VOLUTE CASING	7748	1718H	1	35	PED DRAIN PLUG	P00004	11990	1
2	*IMPELLER	7759-B	1718H	1	36	*BALL BEARING	S01030	-----	1
3	*SEAL ASSEMBLY	25271-773	-----	1	37	*BEARING CAP	4998	10010	1
4	*SUCT FLANGE GSKT	1679-GD	19050	1	38	STUD	C00607	15991	6
5	*FLAP VALVE SEAT	7261	17070	1	39	LOCKWASHER	J00006	15991	6
6	*FLAP VALVE SEAT GASKET	7261-GC	19050	2	40	HEX NUT	D00006	15991	6
7	ACCESSORY PLUG	P00004	17090	1	41	STUD	C00810	17090	8
8	DISCH FLANGE	1758	17070	1	42	HEX NUT	D00008	17090	8
9	*DISCH FLANGE GSKT	1679-GD	19050	1	43	*VOL GASKET SET	34-GC	19050	1
10	LOCKWASHER	J00012	17090	8	44	*WEAR PLATE	2545-X	1718H	1
11	HEX HD CAPSCREW	B01208	17090	8	45	VOL DRAIN PLUG	P00016	17090	1
12	FILL COVER CLAMP BAR	38111-004	11000	1	46	COVER DRAIN PLUG	P00008	17090	1
13	MACHINE BOLT	A01014	15991	2	47	*COVER	42111-949	-----	1
14	FILL COVER CLAMP SCREW	31912-009	15000	1	48	LOCKWASHER	J00008	17090	2
15	FILL COVER	42111-385	-----	1	49	HEX NUT	D00008	17090	2
16	*FILL COVER GSKT	50-G	19210	1	50	COVER CLAMP BAR	2547	11000	1
17	PIPE PLUG	P00004	17090	1	51	COVER CLAMP SCREW	2536	24000	1
18	*DEFLECTOR	3209	19120	1	52	*COVER GASKET	7668-GC	19050	1
19	*VENTED PED PLUG	4823	11990	1	53	STUD	C01214	17090	8
20	PEDESTAL	3020	10010	1	54	HEX NUT	D00012	17090	8
21	*BALL BEARING	S01066	-----	1	55	CHECK VALVE ASSY	7265-B	-----	1
22	*BRG RETAINING RING	S00272	-----	1		* VALVE WEIGHT	7262	17090	1
23	*IMPELLER SHAFT	11904	1706H	1		* VALVE WEIGHT	7263	17090	1
24	*SHAFT KEY	N00615	15990	1		* CHECK VALVE	7264-B	21010	1
25	*SEAL PLATE	11895-B	1718H	1		HEX HD CAPSCREW	B00403	17090	2
26	*SEAL CLAMP	11899	17070	1		LOCKWASHER	J00004	17090	2
27	PIPE PLUG	P00004	17090	1	56	RD HD MACH SCREW	X00404	17090	2
28	*SHAFT SLEEVE	11906	17090	1	57	SUCTION FLANGE	1758	17190	1
29	STUD	C00607	17090	2		NOT SHOWN:			
30	HEX NUT	D00006	17090	2		NAME PLATE	2613-D	13990	1
31	*IMPELLER WASHER	3039-A	17090	1		ROTATION DECAL	2613-CU	00000	1
32	*IMPELLER CAPSCREW	BT01004-S	17090	1		TRASH PUMP DECAL	6588-AV	00000	1
33	*IMP SHIM SET	5091	17090	1		COVER WARNING	38816-097	13990	1
34	*BRG SHIM SET	8546	15990	1		PLATE			
						FILL COVER	2613-EV	13990	1
						WARNING PLATE			

*INDICATES PARTS RECOMMENDED FOR STOCK

Above Serial Numbers Do Not Apply To Pumps Made In Canada.

CANADIAN SERIAL NO AND UP

PUMP AND SEAL DISASSEMBLY AND REASSEMBLY

This pump requires little service due to its rugged, minimum-maintenance design. If it becomes necessary to inspect and/or replace the wearing parts, however, follow these instructions, which are keyed to the sectional view (see figure 1) and the accompanying parts list.

By removing the back cover plate and power source, all service functions except the check valve maintenance can be performed without disconnecting the suction or discharge piping.

Before attempting to service the pump, disconnect the power source, and close all connecting valves.

WARNING

```

////////////////////////////////////
//                               //
// If this pump is used to pump volatile or corrosive flu- //
// ids, wear protective safety equipment, such as goggles //
// and rubber gloves and apron, when working on the pump. //
//                               //
////////////////////////////////////

```

Suction Check Valve Disassembly

Remove the suction piping. Remove hex nuts (54) securing the suction flange (57) to the volute casing (1). Pull the check valve assembly (55) along with the gaskets (4 and 6) and valve seat (5) from the suction port opening. Remove the capscrews and lockwashers securing the valve weights to the valve gasket.

Pump Disassembly

Remove the volute drain plug (45) and drain the pump. For access to the wear plate (44), impeller (2), and seal assembly (3), loosen the clamp bar screw (51) and remove the clamp bar (50). Pull the back cover (47) from the volute. Inspect the wear plate, and replace it if severely scored or worn.

Immobilize the impeller by placing a block of wood between the vanes. Remove the impeller capscrew (32) and the impeller washer (31). Turn the drive end of the shaft counterclockwise and unscrew the impeller. Inspect the impeller, and replace it if cracked or badly worn.

Remove the impeller adjusting shims (33). For ease of reassembly, tag and tie the shims, or measure and record their thickness.

Seal Disassembly

There are three setscrews around the circumference of the seal retainer. These screws secure the seal assembly to the shaft sleeve (28) and ensure proper

spring tension. Remove the shaft sleeve and the seal assembly - with the exception of the stationary seat and gaskets - as a complete unit. **Do not loosen the seal retainer setscrews until the distance between the impeller end of the seal retainer and the impeller end of the shaft sleeve has been measured and recorded. This measurement is critical.**

Using an allen wrench, loosen the seal retainer setscrews, and slide the seal assembly off the shaft sleeve.

To remove the stationary seal seat and gaskets, the seal plate (25) must be separated from the impeller shaft. (See **Impeller Shaft And Bearing Disassembly**) After the seal plate has been disassembled, remove the hex nuts (30) securing the seal clamp (26) and seal components.

Clean the seal plate cavity, the seal clamp cavity, and shaft with a soft cloth soaked in cleaning solvent.

WARNING

```

////////////////////////////////////
//
// Most cleaning solvents are toxic and flammable. Use //
// them only in a well-ventilated area free from excessive //
// heat, sparks, and flame. Read and follow all prec- //
// autions printed on solvent containers. //
// //
////////////////////////////////////
```

If no further disassembly is required see **Seal Reassembly**.

Impeller Shaft And Bearing Disassembly

Remove power source and pedestal mounting hardware to provide clearance.

Remove hex nuts (42) and separate the volute gasket set (43), seal plate (25), and pedestal (20) from volute casing. Record the thickness of the gasket set.

Drain the bearing lubricant by removing the pedestal drain plug (35). Clean and reinstall the drain plug.

Remove the slinger ring (18) and shaft key (24).

Remove the hex nuts (40) and lockwashers (39) securing the bearing cap (37) to the pedestal.

Remove the bearing retaining ring (22) and shim set (34). Tie and tag the shim set, or measure and record their thickness.

Place a block of wood against the drive end of the shaft and force the shaft and bearings out of the pedestal.

Use a bearing puller to remove the inboard bearing (36) and outboard bearing (21) from the impeller shaft.

Impeller Shaft And Bearing Reassembly

Clean the bore of the pedestal and all component parts with a cloth soaked in cleaning solvent. Inspect the parts for wear, and replace as necessary.

WARNING

```

////////////////////////////////////
//
// Most cleaning solvents are toxic and flammable. Use //
// them only in a well-ventilated area free from excessive //
// heat, sparks, and flame. Read and follow all prec- //
// autions printed on solvent containers. //
// //
////////////////////////////////////

```

Soak the bearings in cleaning solvent free of grit or metallic particles. Inspect the bearings, and replace as necessary.

Press the inboard and outboard bearings onto the impeller shaft until they seat squarely against the shaft shoulders.

NOTE

Shielded side of bearings must face away from shaft shoulder to insure proper bearing lubrication.

Press the shaft and assembled bearings into the pedestal bore until the inboard bearing snap ring seats squarely against the pedestal shoulder.

Apply a light coat of "Loctite Plastic Gasket" or equivalent to the contacting surface of the bearing cap and secure it to the pedestal using the attaching hardware.

Install required number of bearing shims.

NOTE

Shaft endplay should be between .002 and .010 inch.

Install the bearing retaining ring and check the shaft end play. Adjust the shaft travel as required.

Install the slinger ring and shaft key.

Secure the volute gasket set, seal plate, and pedestal to the volute housing. Be sure to use the same thickness of gaskets as were removed.

NOTE

Do not install the seal plate at this time if the seal assembly is to be replaced. Push a new stationary seat and gasket into the seal clamp and secure it to the seal plate before further reassembly.

Install pedestal mounting hardware and connect the power source.

Lubricate the pedestal as indicated in the LUBRICATION, Section E.

Seal Reassembly

The seal is not normally reused because of the high polish on its lapped faces, but if it is necessary to reuse the old seal, wash all metallic parts in cleaning solvent and dry thoroughly.

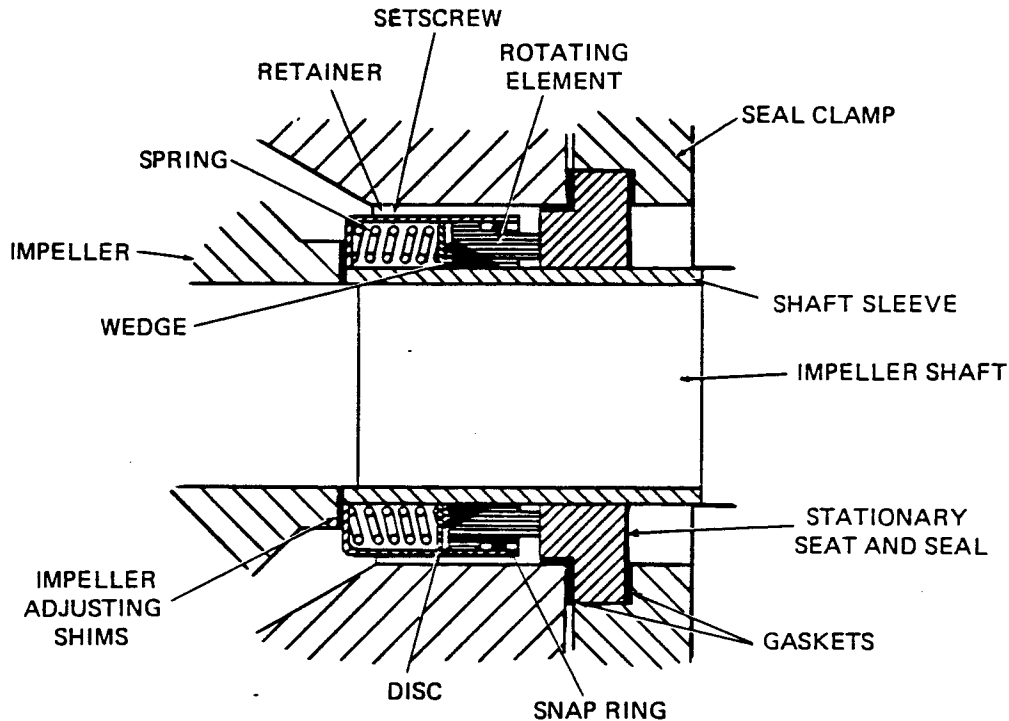

Figure 2. 25271-773 Seal Assembly

Inspect the seal components for wear, scoring, grooves, and other damage that might cause leakage. If any components are worn, replace the complete seal; never mix old and new seal parts.

See figure 2 for the correct order of installation of seal components.

CAUTION

This seal is not designed for operation at temperatures above 160°F. Do not use at higher operating temperatures.

Clean and polish the shaft sleeve, or replace it if there nicks or cuts on the end.

Place a drop of light lubricating oil on the lapped faces of the seal.

If the **old seal** assembly is being reinstalled, inspect the stationary seat and gaskets. Reassemble the parts in seal clamp and secure the seal clamp to the seal plate.

Lubricate the wedge and disc with soft grease or oil, and slide the balance of the old seal assembly onto the shaft sleeve. Refer to the measurement taken before the seal retainer setscrews were loosened, position the seal retainer at the same distance between the impeller end of the retainer and the impeller end of the shaft sleeve, and tighten the setscrews. Slide the shaft sleeve and seal assembly onto the shaft as a complete unit.

If a completely **new seal** assembly is being installed, the seal plate must be separated from the impeller shaft. Install the stationary seat and gaskets into the seal clamp, and secure the seal clamp to the seal plate. Reassemble the seal plate to the volute casing and pedestal assemblies.

Lubricate the wedge and disc with soft grease or oil, and slide the balance of the new seal assembly onto the shaft sleeve. The new assembly is furnished with restraining clips which keep the seal spring under proper tension. Lubricate the wedge and disc with soft grease or oil, and slide the seal assembly onto the shaft sleeve. Refer to the measurement taken before the seal retainer setscrews on the old seal assembly were loosened, position the seal retainer at the same distance between the impeller end of the retainer and the impeller end of the shaft sleeve, and tighten the setscrews. Slide the shaft sleeve and seal assembly onto the shaft as complete unit, and **remove and discard the seal spring restraining clips**.

CAUTION

Be certain to remove the seal spring restraining clips before proceeding with pump reassembly. If the pump is operated with these clips in place, serious damage to both the seal assembly and the pump could result.

Pump Reassembly

Slide the required number of impeller shims onto the shaft and screw the impeller completely on.

A clearance of .020 to .040 inch between the impeller and the seal plate is necessary for maximum pump efficiency. This clearance can be reached by adjusting the impeller shims.

Rotate the shaft by hand, and subtract impeller shims until the impeller binds against the seal plate. After the impeller binds, add .030 inch of impeller shims. Apply a light coat of "Never-Seez" compound on the threads of the impeller capscrew and install the impeller washer. Torque the capscrew to 90 ft. lbs.

A clearance of .008 to .015 inch between the impeller and wear plate is also critical to pump performance. This clearance may be adjusted by adding or subtracting volute casing gaskets.

To measure the clearance, install the back cover assembly and reach through the discharge port with a feeler gauge. If disassembly of the discharge piping is not practical, rotate the shaft by hand and subtract gaskets until the impeller binds against the wear plate. After the impeller binds, add .010 inch of gaskets then reassemble the pump.

Suction Check Valve Reassembly

Clean and inspect all the components of the check valve assembly. Replace any parts that are worn or damaged.

Secure the valve gasket between the valve weights using the two capscrews and lockwashers.

Position the check valve assembly into the valve seat pivot bracket.

Place a new flange gasket on each side of the valve seat and install the complete assembly into the suction port.

Secure the suction flange using hex nuts.

Check the operation of the suction check valve to insure the proper seating and free movement. Reinstall the suction piping.

LUBRICATION

Seal Assembly

This seal is lubricated by the medium being pumped.

Bearings

When shipped from the factory, the pump contains sufficient grease to lubricate the bearings for approximately 5,000 operating hours. Do not lubricate sooner than required. When additional grease is required, remove the vented pedestal plug (19) and add No. 0 pressure gun grease until the cavity is approximately one-third full, or just below the shaft. Clean and reinstall the vented pedestal plug.

**For U.S. and International Warranty Information,
Please Visit www.grpumps.com/warranty
or call:
U.S.: 419-755-1280
International: +1-419-755-1352**

**For Canadian Warranty Information,
Please Visit www.grcanada.com/warranty
or call:
519-631-2870**