**INSTALLATION, OPERATION,
AND MAINTENANCE MANUAL**
WITH PARTS LIST



10-SERIES PUMP

MODEL
14A57-B

THE GORMAN-RUPP COMPANY • MANSFIELD, OHIO
GORMAN-RUPP OF CANADA LIMITED • ST. THOMAS, ONTARIO, CANADA Printed in U.S.A.

TABLE OF CONTENTS

INTRODUCTION	I-1
WARNINGS - SECTION A	A-1
INSTALLATION - SECTION B	B-1
Pump Dimensions	B-1
PREINSTALLATION INSPECTION	B-2
POSITIONING PUMP	B-2
Lifting	B-2
Mounting	B-3
Clearance	B-3
SUCTION AND DISCHARGE PIPING	B-3
Materials	B-3
Line Configuration	B-3
Connections to Pump	B-3
Gauges	B-4
SUCTION LINES	B-4
Fittings	B-4
Strainers	B-4
Sealing	B-5
Suction Line Positioning	B-5
DISCHARGE LINES	B-6
Siphoning	B-6
Valves	B-6
Bypass Lines	B-6
ALIGNMENT	B-7
Coupled Drives	B-7
V-Belt Drives	B-8
OPERATION - SECTION C	C-1
PRIMING	C-1
STARTING	C-2
Rotation	C-2
OPERATION	C-2
Lines With a Bypass	C-2
Lines Without a Bypass	C-3
Leakage	C-3
Liquid Temperature And Overheating	C-3
Strainer Check	C-4
Pump Vacuum Check	C-4
STOPPING	C-4
Cold Weather Preservation	C-4
BEARING TEMPERATURE CHECK	C-5
PUMP TROUBLESHOOTING - SECTION D	D-1
PUMP MAINTENANCE AND REPAIR - SECTION E	E-1
PERFORMANCE CURVE	E-1
PUMP MODEL - PARTS LIST	E-3
PUMP AND SEAL DISASSEMBLY AND REASSEMBLY	E-4
Suction Check Valve Removal And Disassembly	E-4
Back Cover Removal	E-5
Pump Casing Removal	E-5
Impeller Removal	E-5
Packing Removal	E-6
Shaft And Bearing Removal And Disassembly	E-6
Shaft and Bearing Reassembly And Installation	E-7
Packing Installation	E-9
Impeller Installation	E-12
Pump Casing Installation	E-12
Back Cover Installation	E-13

Suction Check Valve Installation	E-13
Final Packing Adjustment	E-14
Final Pump Reassembly	E-14
LUBRICATION	E-14
Packing Assembly	E-14
Bearings	E-15
Power Source	E-15

INTRODUCTION

This Installation, Operation, and Maintenance Manual is designed to help you achieve the best performance and longest life from your Gorman-Rupp pump.

This pump is a 10 Series, semi-open impeller, self-priming centrifugal model with a suction check valve. The pump is designed for handling liquids containing specified entrained solids, residues and solutions that can be highly corrosive. The basic material of construction for wetted parts is Alloy 20 stainless steel. This alloy has a high nickel content, making it ideal for chemical and acid applications.

If there are any questions regarding the pump or application which are not covered in this manual or in other literature accompanying this unit, please contact your Gorman-Rupp distributor, or write:

The Gorman-Rupp Company	or	Gorman-Rupp of Canada Limited
P.O. Box 1217		70 Burwell Road
Mansfield, Ohio 44901-1217		St. Thomas, Ontario N5P 3R7

For information or technical assistance on the power source, contact the power source manufacturer's local dealer or representative.

The following are used to alert maintenance personnel to procedures which require special attention, to those which could damage equipment, and to those which could be dangerous to personnel:

NOTE

Instructions to aid in installation, operation, and maintenance or which clarify a procedure.

CAUTION

Instructions which must be followed to avoid causing damage to the product or other equipment incidental to the installation. These instructions describe the requirements and the possible damage which could result from failure to follow the procedures.

WARNING

```

////////////////////////////////////
//
// These instructions must be followed to avoid causing in- //
// jury or death to personnel, and describe the procedure //
// required and the injury which could result from failure //
// to follow the procedure. //
// //
////////////////////////////////////

```

WARNINGS

WARNINGS - SECTION A

THESE WARNINGS APPLY TO 10 SERIES BASIC PUMPS. GORMAN-RUPP HAS NO CONTROL OVER OR PARTICULAR KNOWLEDGE OF THE POWER SOURCE WHICH WILL BE USED. REFER TO THE MANUAL ACCOMPANYING THE POWER SOURCE BEFORE ATTEMPTING TO BEGIN OPERATION.

WARNING

Before attempting to open or service the pump:
1. Familiarize yourself with this manual.
2. Lock out or disconnect the power source to ensure that the pump will remain inoperative.
3. Allow the pump to cool if overheated.
4. Vent the pump slowly and cautiously.
5. Close the suction and discharge valves.
6. Check the temperature before opening any covers, plates, or plugs.
7. Drain the pump.

WARNING

This pump is designed to handle liquids containing specified entrained solids, residues and solutions that can be highly corrosive. Do not attempt to pump volatile or flammable liquids which may damage the pump or endanger personnel as a result of pump failure.

WARNING

This pump is designed to pump materials which could cause serious illness or injury through direct exposure or emitted fumes. Wear protective clothing, such as rubber gloves, face mask, and rubber apron, as necessary before disassembling the pump or piping.

WARNING

After the pump is installed, make sure the pump and all piping or hose connections are tight, properly supported and secure before operation.

WARNINGS

WARNING

```

////////////////////////////////////
//
// Do not operate the pump without shields and/or guards in //
// place over the drive shafts, belts and/or couplings, or //
// other rotating parts. Exposed rotating parts can catch //
// clothing, fingers, or tools, causing severe injury to //
// personnel. //
//
////////////////////////////////////

```

WARNING

```

////////////////////////////////////
//
// Do not operate the pump against a closed discharge valve //
// for long periods of time. This could bring the liquid //
// to a boil, build pressure, and cause the pump to rupture //
// or explode. //
//
////////////////////////////////////

```

WARNING

```

////////////////////////////////////
//
// Overheated pumps can cause severe burns and injury. If //
// overheating of the pump occurs: //
//
// 1. Stop the pump immediately. //
// 2. Allow the pump to cool. //
// 3. Refer to instructions in this manual before re- //
// starting the pump. //
//
////////////////////////////////////

```

WARNING

```

////////////////////////////////////
//
// Do not remove plates, covers, gauges, pipe plugs, or //
// fittings from an overheated pump. Vapor pressure within //
// the pump can cause parts being disengaged to be ejected //
// with great force. Allow the pump to cool before servic- //
// ing. //
//
////////////////////////////////////

```

INSTALLATION

INSTALLATION - SECTION B

Since pump installations are seldom identical, this section offers only general recommendations and practices required to inspect, position, and arrange the pump and piping.

Most of the information pertains to a standard **static lift application** where the pump is positioned above the free level of liquid to be pumped.

If installed in a **flooded suction application** where the liquid is supplied to the pump under pressure, some of the information such as mounting, line configuration, and priming must be tailored to the specific application. Since the pressure supplied to the pump is critical to performance and safety, **be sure** to limit the incoming pressure to 50% of the maximum permissible operating pressure as shown on the pump performance curve.

For further assistance, contact your Gorman-Rupp distributor or the Gorman-Rupp Company.

Pump Dimensions

See Figure 1 for the approximate physical dimensions of this pump assembly.

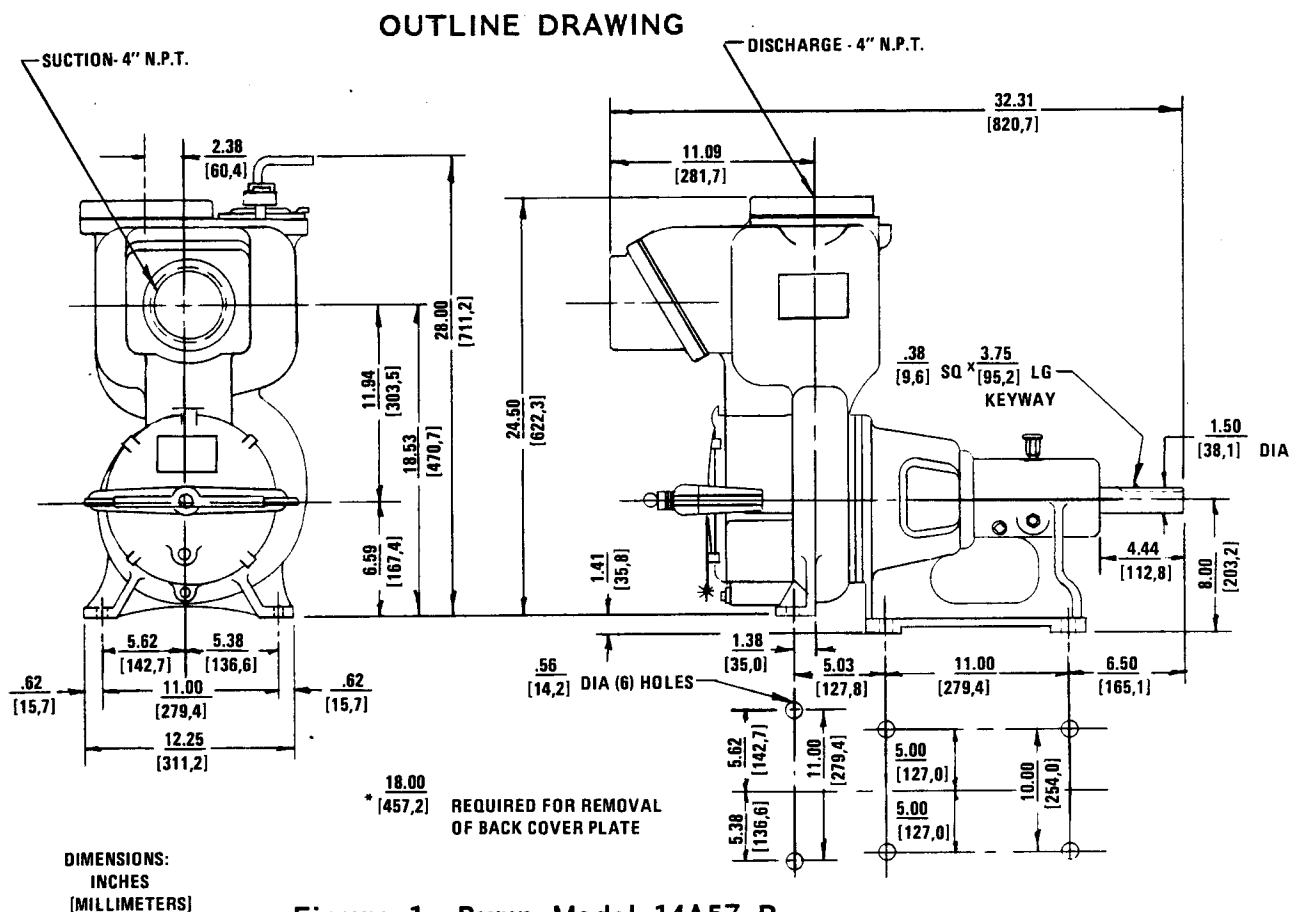

Figure 1. Pump Model 14A57-B

PREINSTALLATION INSPECTION

The pump assembly was inspected and tested before shipment from the factory. Before installation, inspect the pump for damage which may have occurred during shipment. Check as follows:

- a. Inspect the pump assembly for cracks, dents, damaged threads, and other obvious damage.
- b. Check for and tighten loose attaching hardware. Since gaskets tend to shrink after drying, check for loose hardware at mating surfaces.
- c. Carefully read all warning and cautions contained in this manual or affixed to the pump, and perform all duties indicated. Note the direction of rotation indicated on the pump. Check that the pump shaft rotates counterclockwise when facing the impeller.

CAUTION

Only operate this pump in the direction indicated by the arrow on the pump body and on the accompanying decal. Refer to Rotation, Section C.

- d. Check all lubricant levels and lubricate as necessary. Refer to LUBRICATION in the MAINTENANCE AND REPAIR section of this manual and perform duties as instructed.
- e. If the pump and power source have been stored for more than 12 months, some of the components or lubricants may have exceeded their maximum shelf life. These **must be inspected or replaced** to ensure maximum pump service.

If the maximum shelf life has been exceeded, or if anything appears to be abnormal, contact your Gorman-Rupp distributor or the factory to determine the repair or updating policy. **Do not** put the pump into service until appropriate action has been taken.

POSITIONING PUMP

Lifting

Use lifting equipment with a capacity of at least **1,500 pounds**. This pump weighs approximately **300 pounds**, not including the weight of accessories and base and power source. Customer installed equipment such as suction and discharge piping **must** be removed before attempting to lift.

CAUTION

The pump assembly can be seriously damaged if the cables or chains used to lift and move the unit are improperly wrapped around the pump.

Mounting

Locate the pump in an accessible place as close as practical to the liquid being pumped. Level mounting is essential for proper operation.

Clearance

A minimum clearance of **18 inches** in front of the cover plate is required to permit removal of the cover and easy access to the pump interior.

SUCTION AND DISCHARGE PIPING

Materials

Either pipe or hose may be used for suction and discharge lines; however, the materials must be compatible with the liquid being pumped. If hose is used in suction lines, it must be the rigid-wall, reinforced type to prevent collapse under suction. Using piping couplings in suction lines is not recommended.

Line Configuration

Keep suction and discharge lines as straight as possible to minimize friction losses. Make minimum use of elbows and fittings, which substantially increase friction loss. If elbows are necessary, use the long-radius type to minimize friction loss.

Connections to Pump

Before tightening a connecting flange, align it exactly with the pump port. Never pull a pipe line into place by tightening the flange bolts and/or couplings.

INSTALLATION

Lines near the pump must be independently supported to avoid strain on the pump which could cause excessive vibration, decreased bearing life, and increased shaft and seal wear. If hose-type lines are used, they should have adequate support to secure them when filled with liquid and under pressure.

Gauges

Most pumps are drilled and tapped for installing discharge pressure and vacuum suction gauges. If these gauges are desired for pumps that are not tapped, drill and tap the suction and discharge lines not less than 18 inches from the suction and discharge ports and install the lines. Installation closer to the pump may result in erratic readings.

SUCTION LINES

To avoid air pockets which could affect pump priming, the suction line must be as short and direct as possible. When operation involves a suction lift, the line must always slope upward to the pump from the source of the liquid being pumped; if the line slopes down to the pump at any point along the suction run, air pockets will be created.

Fittings

Suction lines should be the same size as the pump inlet. If reducers are used in suction lines, they should be the eccentric type, and should be installed with the flat part of the reducers uppermost to avoid creating air pockets. Valves are not normally used in suction lines, but if a valve is used, install it with the stem horizontal to avoid air pockets.

Strainers

If a strainer is furnished with the pump, be certain to use it; any spherical solids which pass through a strainer furnished with the pump will also pass through the pump itself.

If a strainer is not furnished with the pump, but is installed by the pump user, make certain that the total area of the openings in the strainer is at least three or four times the cross section of the suction line, and that the openings will not permit passage of solids larger than the solids handling capability of the pump.

This pump is designed to handle up to 1 7/8 inch diameter spherical solids.

Sealing

Since even a slight leak will affect priming, head, and capacity, especially when operating with a high suction lift, all connections in the suction line should be sealed with pipe dope to ensure an airtight seal. Follow the sealant manufacturer's recommendations when selecting and applying the pipe dope. The pipe dope should be compatible with the liquid being pumped.

Suction Line Positioning

The depth of submergence of the suction line is critical to efficient pump operation. Figure 2 shows recommended minimum submergence vs. velocity.

NOTE

The pipe submergence required may be reduced by installing a standard pipe increaser fitting at the end of the suction line. The larger opening size will reduce the inlet velocity. Calculate the required submergence using the following formula based on the increased opening size (area or diameter).

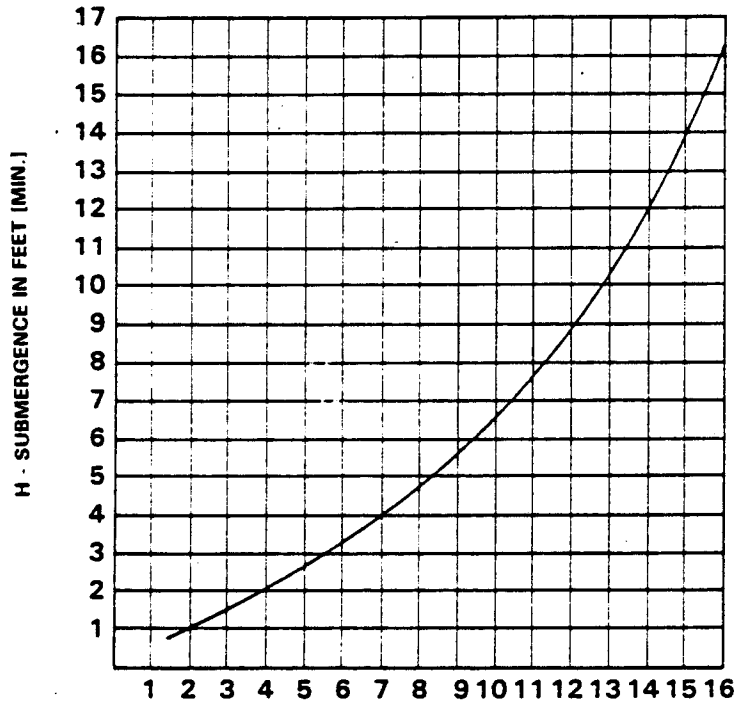

$$VELOCITY \text{ IN FEET PER SEC.} = \frac{QUAN. [G.P.M.] \times .321}{AREA} \text{ OR } \frac{G.P.M. \times .4085}{D^2}$$

Figure 2. Recommended Minimum Suction Line Submergence Vs. Velocity

INSTALLATION

DISCHARGE LINES

Siphoning

Do not terminate the discharge line at a level lower than that of the liquid being pumped unless a siphon breaker is used in the line. Otherwise, a siphoning action causing damage to the pump could result.

Valves

If a throttling valve is desired in the discharge line, use a valve as large as the largest pipe to minimize friction losses. Never install a throttling valve in a suction line.

With high discharge heads, it is recommended that a throttling valve and a system check valve be installed in the discharge line to protect the pump from excessive shock pressure and reverse rotation when it is stopped.

CAUTION

If application involves a high discharge head, gradually close the discharge throttling valve before stopping the pump.

Bypass Lines

If it is necessary to permit the escape of air to atmosphere during initial priming or in the repriming cycle, install a bypass line between the pump and the discharge check valve. The bypass line should be sized so that it does not affect pump discharge capacity.

It is recommended that a Gorman-Rupp Automatic Air Release Valve be installed in the bypass line. Do not install a manual shut-off valve in a bypass line. If a manual shut-off valve is installed to facilitate service of the Air Release Valve, the valve **must not** be left closed during operation. See the supplement at the end of this section for additional information on bypass lines and the Gorman-Rupp Automatic Air Release Valve.

NOTE

The bypass line may clog occasionally, particularly when pumping liquids containing large solids. If clogging occurs, locate and remove the clog. If the clog is located between the discharge check valve and the Air Release Valve, the valve will not close. If the clog is located in the Relief Valve itself, or in the line between the Relief Valve and the sump, the valve will not open.

Do not terminate the discharge line at a level lower than that of the liquid being pumped unless a siphon breaker is used in the line; otherwise, a siphoning action could result, causing damage to the pump.

ALIGNMENT

The alignment of the pump and its power source is critical for trouble-free mechanical operation. In either a flexible coupling or V-belt driven system, the driver and pump must be mounted so that their shafts are aligned with and parallel to each other. It is imperative that alignment be checked after the pump and piping are installed, and before operation.

NOTE

Check **Rotation**, Section C, before final alignment of the pump.

When mounted at the Gorman-Rupp factory, driver and pump are aligned before shipment. Misalignment will occur in transit and handling. Pumps **must** be checked and realigned before operation. Before checking alignment, tighten the foundation bolts. The pump casing feet and/or pedestal feet, and the driver mounting bolts should also be tightly secured.

WARNING

```

////////////////////////////////////
//                               //
// When checking alignment, disconnect the power source to //
// ensure that the pump will remain inoperative.           //
//                               //
////////////////////////////////////

```

CAUTION

<p>Adjusting the alignment in one direction may alter the alignment in another direction. Check each procedure after altering alignment.</p>
--

Coupled Drives

When using couplings, the axis of the power source must be aligned to the axis of the pump shaft in both the horizontal and vertical planes. Most couplings require a specific gap or clearance between the driving and the driven shafts. Refer to the coupling manufacturer's service literature.

Align spider insert type couplings by using calipers to measure the dimensions on the circumference of the outer ends of the coupling hub every 90 degrees. The coupling is in alignment when the hub ends are the same distance apart at all points (see Figure 3A).

Align non-spider type couplings by using a feeler gauge or taper gauge between the coupling halves every 90 degrees. The coupling is in alignment when the hubs are the same distance apart at all points (see Figure 3B).

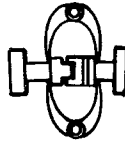

Figure 3A. Aligning Spider-Type Couplings

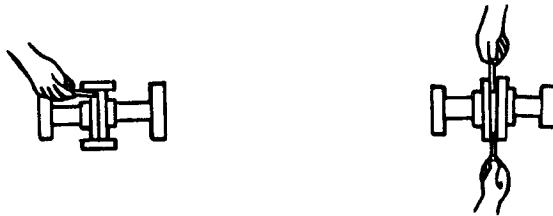

Figure 3B. Aligning Non-Spider Type Couplings

Check parallel adjustment by laying a straightedge across both coupling rims at the top, bottom, and side. When the straightedge rests evenly on both halves of the coupling, the coupling is in horizontal parallel alignment. If the coupling is misaligned, use a feeler gauge between the coupling and the straightedge to measure the amount of misalignment.

V-Belt Drives

When using V-belt drives, the power source and the pump must be parallel. Use a straightedge along the sides of the pulleys to ensure that the pulleys are properly aligned (see Figure 3C). In drive systems using two or more belts, make certain that the belts are a matched set; unmatched sets will cause accelerated belt wear.



Figure 3C. Alignment of V-Belt Driven Pumps

Tighten the belts in accordance with the belt manufacturer's instructions. If the belts are too loose, they will slip; if the belts are too tight, there will be excessive power loss and possible bearing failure. Select pulleys that will match the proper speed ratio; overspeeding the pump may damage both pump and power source.

WARNING

```
////////////////////////////////////  
//  
// Do not operate the pump without shields and/or guards in //  
// place over the drive shafts, belts and/or couplings, or //  
// other rotating parts. Exposed rotating parts can catch //  
// clothing, fingers, or tools, causing severe injury to //  
// personnel. //  
// //  
////////////////////////////////////
```

GORMAN-RUPP AUTOMATIC AIR RELEASE VALVE

Bypass Lines

Self-priming pumps are not air compressors. During the priming cycle, air from the suction line must be vented to atmosphere on the discharge side. If a check valve has been installed in the discharge line, the discharge side of the pump must be opened to atmospheric pressure through a bypass line between the pump discharge and the check valve. A self-priming centrifugal pump **will not prime** if there is sufficient static liquid head to hold the discharge check valve closed.

In **low discharge head applications** (less than 30 feet), it is recommended that the bypass line be run back to the wet well, and located 6 inches below the water level or cut-off point of the low level pump. The bypass line should be at least 1 inch in diameter to minimize the chance of plugging. The bypass line may be terminated with a six-to-eight foot length of 1 1/4 inch I.D. **smooth-bore** hose; air and liquid will then agitate the hose and break up any substances likely to cause clogging. It is also recommended that pipe unions be installed at each 90° elbow in a bypass line to ease disassembly and maintenance.



A BYPASS LINE THAT IS RETURNED TO A WET WELL MUST BE SECURED AGAINST BEING DRAWN INTO THE PUMP SUCTION INLET.

In **high discharge head applications** (more than 30 feet), an excessive amount of liquid may be bypassed and forced back to the wet well under the full working pressure of the pump; this will reduce overall pumping efficiency. **Therefore, it is recommended that a Gorman-Rupp Automatic Air Release Valve be installed in the bypass line.**

When properly installed and correctly adjusted to the application, the Gorman-Rupp Automatic Air Release Valve will permit air to escape through the bypass line, and then close automatically when the pump is fully primed and pumping at full capacity.

If the installation involves a flooded suction such as a below-ground lift station, a pipe union and manual shut-off valve may be installed in the bleed line to allow service of the valve without shutting down the station, and to eliminate the possibility of flooding. If a manual shut-off valve is installed **anywhere** in the air release piping, it **must** be a full-opening **ball type** valve to prevent plugging by solids.



IF A MANUAL SHUT-OFF VALVE IS INSTALLED IN A BYPASS LINE, IT MUST NOT BE LEFT CLOSED DURING OPERATION. A CLOSED MANUAL SHUT-OFF VALVE MAY CAUSE A PUMP WHICH HAS LOST PRIME TO CONTINUE TO OPERATE WITHOUT REACHING PRIME, CAUSING DANGEROUS OVERHEATING AND POSSIBLE EXPLOSIVE RUPTURE OF THE PUMP CASING. PERSONNEL COULD BE SEVERELY INJURED.

ALLOW AN OVER-HEATED PUMP TO COOL BEFORE SERVICING. DO NOT REMOVE PLATES, COVERS, GAUGES, OR FITTINGS FROM AN OVER-HEATED PUMP. LIQUID WITHIN THE PUMP CAN REACH BOILING TEMPERATURES, AND VAPOR PRESSURE WITHIN THE PUMP CAN CAUSE PARTS BEING DISENGAGED TO BE EJECTED WITH GREAT FORCE. AFTER THE PUMP COOLS, DRAIN THE LIQUID FROM THE PUMP BY REMOVING THE CASING DRAIN PLUG.

Theory of Operation

During the priming cycle, air from the pump casing is discharged through the bypass line, passing through the Air Release Valve (Figure 1). When the pump is fully primed, pressure against the valve diaphragm compresses the spring and closes the valve (Figure 2). The valve will remain closed until the pump loses its prime or stops.

When the pump shuts down, the spring returns the diaphragm to its original position. Any solids that may have accumulated in the diaphragm chamber settle to the bottom and are flushed out during the next priming cycle.

AIR RELEASE VALVE SUPPLEMENT

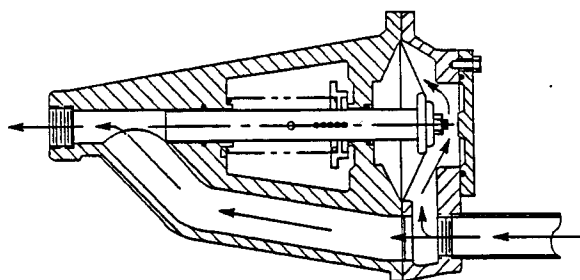

Figure 1. Valve in Open Position

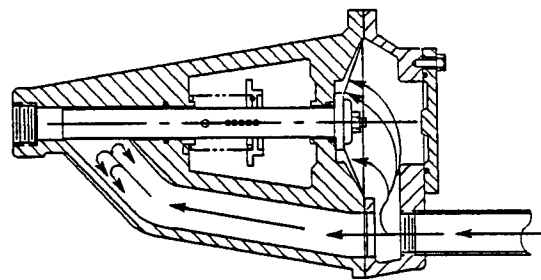
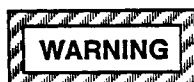

Figure 2. Valve in Closed Position



SOME LEAKAGE (1 TO 5 GPM) WILL OCCUR WHEN THE VALVE IS FULLY CLOSED. BE SURE THE BYPASS LINE IS DIRECTED BACK TO THE WET WELL OR TANK TO PREVENT HAZARDOUS SPILLS.

NOTE

The valve will remain open if the pump does not reach its designed capacity or head. The range of the valve closing pressure is established by the tension rate of the spring as ordered from the factory, and by adjusting the spring retaining pin up or down.

the plunger rod to increase or decrease spring tension.

Air Release Valve Installation

The Automatic Air Release Valve must be independently mounted in a horizontal position between the pump discharge port and the non-pressurized side of the discharge check valve (see Figure 3). The valve inlet is at the large end of the valve body, and is provided with standard 1 inch NPT pipe threads.

NOTE

If the Air Release Valve is to be installed on a staged pump application, contact the factory for specific installation instructions.

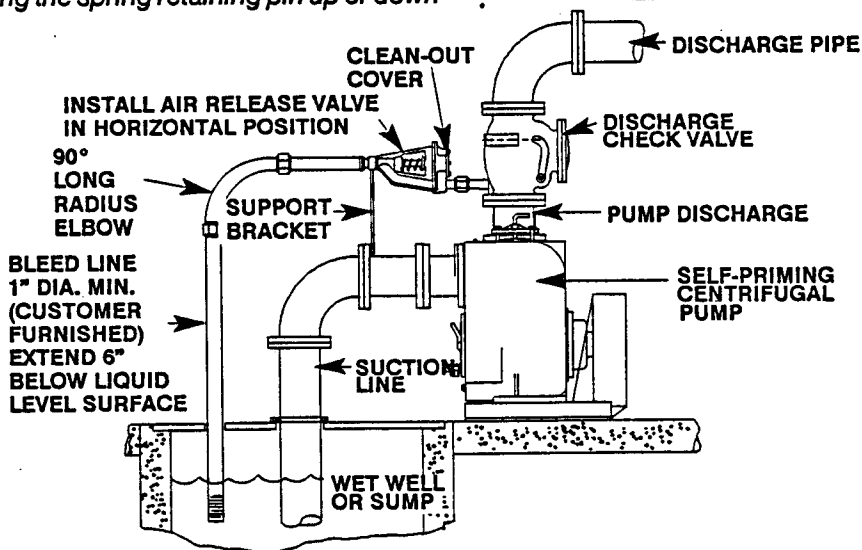

Figure 3. Typical Automatic Air Release Valve Installation

The valve outlet is located at the opposite end of the valve, and is also equipped with standard 1 inch NPT pipe threads. The outlet should be connected to a bleed line which slopes back to the wet well or sump. The bleed line must be the same size as the inlet piping, or larger. If piping is used for the bleed line, avoid the use of elbows whenever possible.

NOTE

It is recommended that each Air Release Valve be fitted with an independent bleeder line. However, if multiple Air Release Valves are installed in a system, the bleeder lines may be directed to a common manifold pipe. Contact the Gorman-Rupp Company for information about your specific application.

OPERATION - SECTION C

WARNING

```

////////////////////////////////////
//
// This pump is designed to handle liquids containing spec- //
// ified entrained solids, residues and solutions that can //
// be highly corrosive. Do not attempt to pump volatile or //
// flammable liquids which may damage the pump or endanger //
// personnel as a result of pump failure. //
//
////////////////////////////////////

```

PRIMING

Install the pump and piping as described in INSTALLATION. Make sure that the piping connections are tight, and that the pump is securely mounted. Check that the pump is properly lubricated (see LUBRICATION in MAINTENANCE AND REPAIR).

This pump is self-priming, but the pump should never be operated unless there is liquid in the casing.

CAUTION

<p>Never operate a self-priming pump unless there is liquid in the casing. The pump will not prime when dry. Extended operation of a dry pump will destroy the seal assembly.</p>

Add liquid to the pump casing when:

1. The pump is being put into service for the first time.
2. The pump has not been used for a considerable length of time.
3. The liquid in the pump casing has evaporated.

Once the pump casing has been filled, the pump will prime as necessary.

WARNING

```

////////////////////////////////////
//
// After filling the pump casing, reinstall and tighten the //
// fill plug. Do not attempt to operate the pump unless //
// all connecting piping is securely installed. Otherwise, //
// liquid in the pump forced out under pressure could cause //
// injury to personnel. //
//
////////////////////////////////////

```

OPERATION

To fill the pump, remove the pump casing fill cover or fill plug at the top of the casing and add clean liquid until the pump is filled. Replace the fill cover or fill plug before operating the pump.

NOTE

This pump is self-priming, however, it is **not** suited for unattended reprime applications. In the event of suction check valve failure and loss of prime, the pump casing **must** be refilled through the fill cover or fill plug.

STARTING

Consult the operations manual furnished with the power source.

Rotation

The correct direction of pump rotation is counterclockwise when facing the impeller. The pump could be damaged and performance adversely affected by incorrect rotation. If pump performance is not within the specified limits (see the curve on page E-1), check the direction of power source rotation before further troubleshooting.

OPERATION**Lines With a Bypass**

It is recommended that a Gorman-Rupp Automatic Air Release Valve be installed in the bypass line. Do not install a manual shut-off valve in a bypass line. If a manual shut-off valve is installed to facilitate service of the Air Release Valve, the valve **must not** be left closed during operation. See the supplement in Section B for additional information on bypass lines and the Gorman-Rupp Automatic Air Release Valve.

When operating with a Gorman-Rupp Automatic Air Release Valve, close the throttling valve in the discharge line. The Automatic Air Release Valve will automatically open to allow the pump to prime, and automatically close when priming has been accomplished. After the pump has primed and liquid is flowing steadily from the bypass line, open the discharge throttling valve.

Lines Without a Bypass

Open all valves in the discharge line and start the power source. Priming is indicated by a positive reading on the discharge pressure gauge or by a quieter

OPERATION

operation. The pump may not prime immediately because the suction line must first fill with liquid. If the pump fails to prime within five minutes, stop it and check the suction line for leaks.

After the pump has been primed, partially close the discharge line throttling valve in order to fill the line slowly and guard against excessive shock pressure which could damage pipe ends, gaskets, sprinkler heads, and any other fixtures connected to the line. When the discharge line is completely filled, adjust the throttling valve to the required flow rate.

Leakage

No leakage should be visible at pump mating surfaces, or at pump connections or fittings. Keep all line connections and fittings tight to maintain maximum pump efficiency.

The packing in the seal plate is lubricated by the liquid being pumped or by a flow of fresh liquid from an external source. A slight flow of liquid through the packing (approximately 50 drops per minute) must be maintained for lubrication. Do not over-tighten the gland nuts and cut off this flow. Refer to Final Packing Adjustment and LUBRICATION in Section E for details.

Liquid Temperature And Overheating

The maximum liquid temperature for this pump is 212° F. Do not apply it at a higher operating temperature.

Overheating can occur if operated with the valves in the suction or discharge lines closed. Operating against closed valves could bring the liquid to a boil, build pressure, and cause the pump to rupture or explode. If overheating occurs, stop the pump and allow it to cool before servicing it. Refill the pump casing with cool liquid.

WARNING

Warning text enclosed in a double-slash format: // Do not remove plates, covers, gauges, pipe plugs, or // fittings from an overheated pump. Vapor pressure within // the pump can cause parts being disengaged to be ejected // with great force. Allow the pump to cool before servic- // ing. //

Strainer Check

If a suction strainer has been shipped with the pump or installed by the user, check the strainer regularly, and clean it as necessary. The strainer should also be checked if pump flow rate begins to drop. If a vacuum suction gauge has been installed, monitor and record the readings regularly to detect strainer blockage.

Never introduce air or steam pressure into the pump casing or piping to remove a blockage. This could result in personal injury or damage to the equipment. If backflushing is absolutely necessary, **liquid pressure** must be limited to 50% of the maximum permissible operating pressure shown on the pump performance curve.

Pump Vacuum Check

With the pump inoperative, install a vacuum gauge in the system, using pipe dope on the threads. Block the suction line and start the pump. At operating speed the pump should pull a vacuum of 20 inches or more of mercury. If it does not, check for air leaks in the seal, gasket, or discharge valve.

Open the suction line, and read the vacuum gauge with the pump primed and at operating speed. Shut off the pump. The vacuum gauge reading will immediately drop proportionate to static suction lift, and should then stabilize. If the vacuum reading falls off rapidly after stabilization, an air leak exists. Before checking for the source of the leak, check the point of installation of the vacuum gauge.

STOPPING

Never halt the flow of liquid suddenly. If the liquid being pumped is stopped abruptly, damaging shock waves can be transmitted to the pump and piping system. Close all connecting valves slowly. On engine driven pumps, reduce the throttle speed slowly and allow the engine to idle briefly before stopping.

CAUTION

If application involves a high discharge head, gradually close the discharge throttling valve before stopping the pump.

After stopping the pump, lock out or disconnect the power source to ensure that the pump will remain inoperative.

Cold Weather Preservation

In below freezing conditions, drain the pump to prevent damage from freezing. Also, clean out any solids by flushing with a hose. Operate the pump for approximately one minute; this will remove any remaining liquid that could freeze the pump rotating parts.

If the pump will be idle for more than a few hours, or if it has been pumping liquids containing a large amount of solids, drain the pump, and flush it thoroughly with clean water. To prevent large solids from clogging the drain port and preventing the pump from completely draining, insert a rod or stiff wire in the drain port, and agitate the liquid during the draining process. Clean out any remaining solids by flushing with a hose.

BEARING TEMPERATURE CHECK

Bearings normally run at higher than ambient temperatures because of heat generated by friction. Temperatures up to 160°F are considered normal for bearings, and they can operate safely to at least 180°F.

Checking bearing temperatures by hand is inaccurate. Bearing temperatures can be measured accurately by placing a contact-type thermometer against the housing. Record this temperature for future reference.

A sudden increase in bearing temperatures is a warning that the bearings are at the point of failing to operate properly. Make certain that the bearing lubricant is of the proper viscosity and at the correct level (see LUBRICATION in MAINTENANCE AND REPAIR). Bearing overheating can also be caused by shaft misalignment and/or excessive vibration.

When pumps are first started, the bearings may seem to run at temperatures above normal. Continued operation should bring the temperatures down to normal levels.

PUMP TROUBLESHOOTING - SECTION D

WARNING

```

////////////////////////////////////
//
// Before attempting to open or service the pump:
//
// 1. Familiarize yourself with this manual.
// 2. Lock out or disconnect the power source to ensure
//    that the pump will remain inoperative.
// 3. Allow the pump to cool if overheated.
// 4. Vent the pump slowly and cautiously.
// 5. Close the suction and discharge valves.
// 6. Check the temperature before opening any covers,
//    plates, or plugs.
// 7. Drain the pump.
//
////////////////////////////////////
    
```

TROUBLE	POSSIBLE CAUSE	PROBABLE REMEDY
PUMP FAILS TO PRIME	Not enough liquid in casing.	Add liquid to casing. See PRIMING.
	Suction check valve contaminated or damaged.	Clean or replace check valve.
	Air leak in suction line.	Correct leak.
	Lining of suction hose collapsed.	Replace suction hose.
	Suction check valve or foot valve clogged or binding.	Clean valve.
	Leaking or worn seal or pump gasket.	Check pump vacuum. Replace leaking or worn seal or gasket.
	Suction lift or discharge head too high.	Check piping installation and install bypass line if needed. See INSTALLATION.
	Strainer clogged.	Check strainer and clean if necessary.
PUMP STOPS OR FAILS TO DELIVER RATED FLOW OR PRESSURE	Air leak in suction line.	Correct leak.
	Suction intake not submerged at proper level or sump too small.	Check installation and correct submergence as needed.

TROUBLE	POSSIBLE CAUSE	PROBABLE REMEDY
PUMP STOPS OR FAILS TO DELIVER RATED FLOW OR PRESSURE (cont.)	<p>Lining of suction hose collapsed.</p> <p>Impeller or other wearing parts worn or damaged.</p> <p>Impeller clogged.</p> <p>Pump speed too slow.</p> <p>Discharge head too high.</p> <p>Suction lift too high.</p> <p>Leaking or worn seal or pump gasket.</p> <p>Packing gland too tight (if so equipped).</p> <p>Strainer clogged.</p>	<p>Replace suction hose.</p> <p>Replace worn or damaged parts. Check that impeller is properly centered and rotates freely.</p> <p>Free impeller of debris.</p> <p>Check driver output; check belts or couplings for slippage.</p> <p>Install bypass line.</p> <p>Measure lift w/vacuum gauge. Reduce lift and/or friction losses in suction line.</p> <p>Check pump vacuum. Replace leaking or worn seal or gasket.</p> <p>Check packing gland and loosen if necessary.</p> <p>Check strainer and clean if necessary.</p>
PUMP REQUIRES TOO MUCH POWER	<p>Pump speed too high.</p> <p>Discharge head too low.</p> <p>Liquid solution too thick.</p> <p>Packing gland too tight (if so equipped).</p>	<p>Check driver output; check that sheaves or couplings are correctly sized.</p> <p>Adjust discharge valve.</p> <p>Dilute if possible.</p> <p>Check packing gland and loosen if necessary.</p>
PUMP CLOGS FREQUENTLY	<p>Discharge flow too slow.</p> <p>Suction check valve or foot valve clogged or binding.</p>	<p>Open discharge valve fully to increase flow rate, and run power source at maximum governed speed.</p> <p>Clean valve.</p>

TROUBLE	POSSIBLE CAUSE	PROBABLE REMEDY
EXCESSIVE NOISE	<p>Cavitation in pump.</p> <p>Pumping entrained air.</p> <p>Pump or drive not securely mounted.</p> <p>Impeller clogged or damaged.</p>	<p>Reduce suction lift and/or friction losses in suction line. Record vacuum and pressure gauge readings and consult local representative or factory.</p> <p>Locate and eliminate source of air bubble.</p> <p>Secure mounting hardware.</p> <p>Clean out debris; replace damaged parts.</p>
BEARINGS RUN TOO HOT	<p>Bearing temperature is high, but within limits.</p> <p>Low or incorrect lubricant.</p> <p>Suction and discharge lines not properly supported.</p> <p>Drive misaligned.</p> <p>Packing gland too tight (if so equipped).</p>	<p>Check bearing temperature regularly to monitor any increase.</p> <p>Check for proper type and level of lubricant.</p> <p>Check piping installation for proper support.</p> <p>Align drive properly.</p> <p>Check packing gland and loosen if necessary.</p>

PUMP MAINTENANCE AND REPAIR - SECTION E

MAINTENANCE AND REPAIR OF THE WEARING PARTS OF THE PUMP WILL MAINTAIN PEAK OPERATING PERFORMANCE.

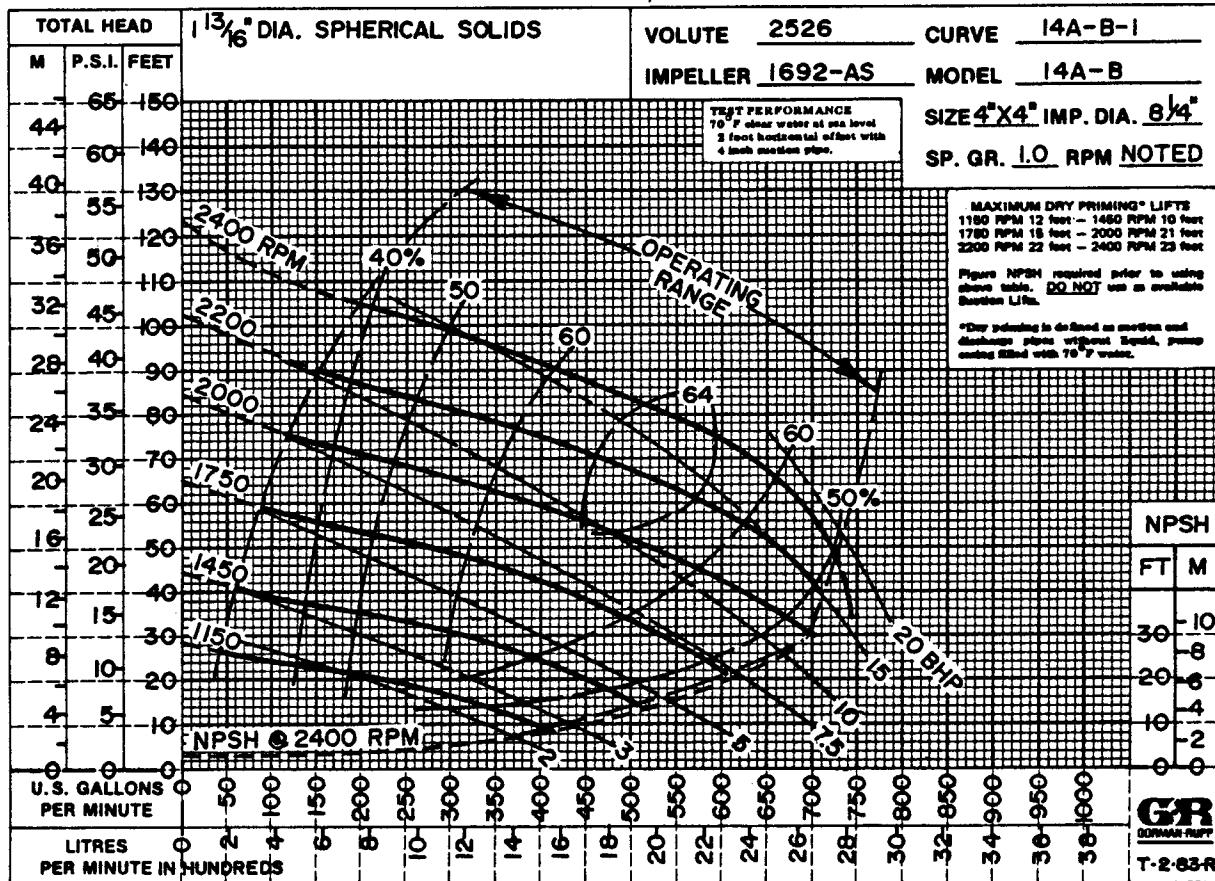

*STANDARD PERFORMANCE FOR PUMP MODEL 14A57-B

*Based on 70°F clear water at sea level with minimum suction lift. Since pump installations are seldom identical, your performance may be different due to such factors as viscosity, specific gravity, elevation, temperature, and impeller trim.

If your pump serial number is followed by an "N", your pump is NOT a standard production model. Contact the Gorman-Rupp Company to verify performance or part numbers.

SECTIONAL DRAWING

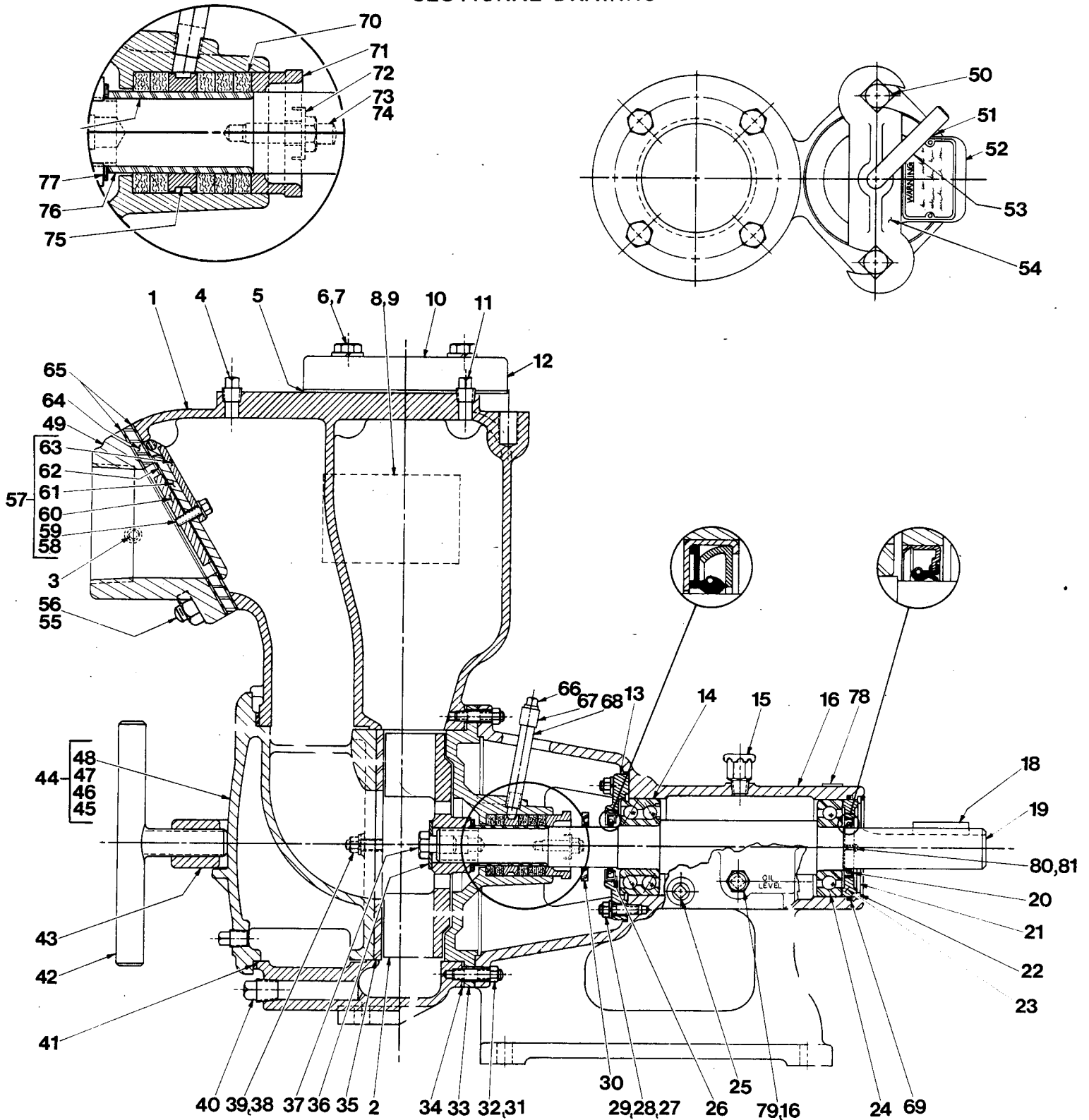

Figure 1. Pump Model 14A57-B

PARTS LIST
PUMP MODEL 14A57-B
 (From S/N 768001 up)

If your pump serial number is followed by an "N", your pump is **NOT** a standard production model. Contact the Gorman-Rupp Company to verify part numbers.

ITEM NO.	PART NAME	PART NUMBER	MATL CODE	QTY	ITEM NO.	PART NAME	PART NUMBER	MATL CODE	QTY
1	PUMP CASING	2526	17190	1	47	-DRIVE SCREW	BM#04-03	17000	4
2	*IMPELLER	1692-AS	17190	1	48	-CVR DRAIN PLUG	P06	17090	1
3	ACCESSORY PLUG	P04	17090	1	49	SUCTION FLANGE	1736	17190	1
4	ACCESSORY PLUG	P06	17090	1	50	MACHINE BOLT	A1012	17090	2
5	*DISCH FLANGE GSKT	1674-GC	19370	1	51	*FILL COVER GSKT	50-G	19210	1
6	HEX HD CAPSCREW	B1008	17090	4	52	FILL COVER ASSY	42111-381	-----	1
7	LOCKWASHER	J10	17090	4	53	CLAMP BAR SCREW	31912-009	15000	1
8	NAME PLATE	38818-023	17010	1	54	CLAMP BAR	38111-004	11010	1
9	DRIVE SCREW	BM#04-03	17000	4	55	STUD	C1011	17090	4
10	DISCH FLANGE	271	17190	1	56	HEX NUT	D10	17090	4
11	ACCESSORY PLUG	P04	17090	1	57	CHECK VALVE ASSY	9820-B	-----	1
12	DISCHARGE STICKER	6588-BJ	-----	1	58	-HEX HD CAPSCREW	B0404	17210	2
13	BEARING CAP	6691-A	10010	1	59	-LOCKWASHER	J04	17210	2
14	*BALL BEARING	S1040	-----	1	60	-VALVE WEIGHT	9819	17210	1
15	PED AIR VENT	S1703	-----	1	61	-VALVE WEIGHT	2936	17190	1
16	PIPE PLUG	P06	11990	1	62	*-VALVE GSKT	9823-G	19540	1
17	PEDESTAL	3064-C	10010	1	63	-VALVE ARM	9818	17210	1
18	*SHAFT KEY	N0608	15990	1	64	CHK VLV SEAT	9817	17210	1
19	*IMPELLER SHAFT	3065-E	17210	1	65	*CHK VLV SEAT GSKT	9817-G	19370	2
20	*OIL SEAL	25258-411	-----	1	66	PIPE PLUG	P04	17090	1
21	BRG RETAINING RING	S271	-----	1	67	PIPE COUPLING	AE04	11990	1
22	*BRG SHIM SET	8543	15990	1	68	PIPE NIPPLE	T0412	15070	1
23	BRG RETAINER	38322-516	26000	1	69	*BRG RET O-RING	S2085	-----	1
24	*BALL BEARING	S1080	-----	1	70	*PACKING	PP0624 1/2	22100	5
25	PED DRAIN PLUG	P06	11990	1	71	SPLIT GLAND	3023	17190	1
26	*OIL SEAL	S1452	-----	1	72	GLAND CLIP	3218	17000	2
27	STUD	C0606	15991	4	73	STUD	C0607	17090	2
28	LOCKWASHER	J06	15991	4	74	DEFORM LOCKNUT	DD06	17090	2
29	HEX NUT	D06	15991	4	75	*LANTERN RING	3395	19250	1
30	*SLINGER RING	2352	19120	1	76	*SHAFT SLEEVE	10368	17210	1
31	STUD	C0608	17090	8	77	*IMP SHIM SET	37-J	17090	1
32	HEX NUT	D06	17090	8	78	ROTATION DECAL	2613-M	-----	1
33	SEAL PLATE	3063-A	17190	1	79	SIGHT GAUGE	26714-011	-----	1
34	*CASING GASKET SET	2474-GD	19370	1	80	RD HD MACH SCREW	X#10-01 1/2S	15991	2
35	*WEAR PLATE	2605-X	17210	1	81	LOCKWASHER	J#10	15991	2
36	*IMPELLER WASHER	3039	17210	1		NOT SHOWN:			
37	*IMPELLER CAPSCREW	BT1004-S	17210	1		SUCTION STICKER	6588-AG	-----	1
38	HEX NUT	D06	17210	2		OPTIONAL:			
39	LOCKWASHER	J06	17210	2		CASING HEATER ASSYS:			
40	CASING DRAIN PLUG	P08	17090	1		-120V	47811-008	-----	1
41	*COVER GASKET	2527-GB	19370	1		-240V	47811-009	-----	1
42	COVER CLAMP SCREW	2536	24000	1		HI TEMP SHUT-DOWN KITS:			
43	COVER CLAMP BAR	2528	11010	1		-120°F	48313-257	-----	1
44	BACK COVER ASSY	42111-946	-----	1		-130°F	48313-256	-----	1
45	-BACK COVER	NOT AVAILABLE		1		-145°F	48313-186	-----	1
46	-WARNING PLATE	2613-EV	17090	1					

*INDICATES PARTS RECOMMENDED FOR STOCK

Above Serial Numbers Do Not Apply To Pumps Made In Canada.

CANADIAN SERIAL NO AND UP

PUMP AND SEAL DISASSEMBLY AND REASSEMBLY

This pump requires little service due to its rugged, minimum-maintenance design. However, if it becomes necessary to inspect or replace the wearing parts, follow these instructions which are keyed to the sectional view(s) (see Figures 1 and 2) and the accompanying parts list(s).

Before attempting to service the pump, lock out or disconnect the power source to ensure that the power source will remain inoperative and close all valves in the suction and discharge lines.

For power source disassembly and repair, consult the literature supplied with the power source, or contact your local power source representative.

WARNING

```

////////////////////////////////////
//
// Before attempting to open or service the pump:
//
// 1. Familiarize yourself with this manual.
// 2. Lock out or disconnect the power source to ensure
//    that the pump will remain inoperative.
// 3. Allow the pump to cool if overheated.
// 4. Vent the pump slowly and cautiously.
// 5. Close the suction and discharge valves.
// 6. Check the temperature before opening any covers,
//    plates, or plugs.
// 7. Drain the pump.
//
////////////////////////////////////

```

WARNING

```

////////////////////////////////////
//
// This pump is designed to pump materials which could
// cause serious illness or injury through direct exposure
// or emitted fumes. Wear protective clothing, such as
// rubber gloves, face mask, and rubber apron, as necessary
// before disassembling the pump or piping.
//
////////////////////////////////////

```

Suction Check Valve Removal And Disassembly

Before attempting to service the check valve assembly (57), remove the casing drain plug (40) and drain the pump. Clean and reinstall the drain plug.

For access to the check valve, remove the suction piping. Remove the nuts (56), and separate the suction flange (49), check valve, check valve seat (64), and gaskets (65) from the pump casing.

Inspect the check valve parts for wear or damage and, if replacement is required, remove the hardware (58 and 59) securing the valve weights (60, 61 and 63) and check valve (62).

Back Cover Removal

The wear plate (35) is easily accessible and may be serviced by removing the back cover assembly (44). Loosen the clamp bar screw (42) and remove the clamp bar (43). Pull the back cover and wear plate from the casing. Remove the back cover gasket (41) and clean the mating surfaces.

Inspect the wear plate for excessive wear or scoring. If replacement is required, remove the hardware (38 and 39) securing it to the back cover.

Pump Casing Removal

For access to the impeller (2) and packing, remove the discharge piping. Remove the hardware securing the pump casing to the base.

Remove the nuts (32) securing the pump casing to the seal plate (33) and pedestal (17). Install a standard 5/8-11 UNC lifting eye in the tapped hole in the pump casing. **Be sure** to screw the eye into the casing until fully engaged. Use a hoist and sling of suitable capacity to separate the pump casing from the pedestal.

WARNING

```

////////////////////////////////////
// Do not attempt to lift the complete pump unit using the //
// lifting eye. It is designed to facilitate removal or //
// installation of individual components only. Additional //
// weight may result in damage to the pump or failure of //
// the eye bolt. //
// //
////////////////////////////////////

```

Remove any leveling shims used under the casing mounting feet. Tie and tag the shims for ease of reassembly.

Remove the pump casing gaskets (34). For ease of reassembly, tie and tag the gaskets, or measure and record their thickness.

Impeller Removal

Remove the impeller capscrew and washer (36 and 37). Disconnect the power source and remove the shaft key (18). Install a lathe dog on the drive end of the shaft with the "V" notch positioned over the keyway. Immobilize the impeller (2) by inserting a block of wood between the vanes. Strike the lathe dog sharply in a counterclockwise direction (when facing the drive end of the shaft) until the impeller breaks loose. After the impeller breaks loose, remove the lathe dog and wood block and unscrew the impeller from the shaft.

Slide the impeller adjusting shims (77) off the impeller shaft. For ease of reassembly, tie and tag the shims, or measure and record their thickness.

Packing Removal

To remove the seal plate (33), and packing (70), remove the locknuts (74) and clips (72) compressing the split packing gland (71). Remove each half of the split gland from the seal plate bore.

Remove the auxiliary lubrication piping (66, 67 and 68) from the seal plate, and carefully slide the seal plate and packing off the shaft. If necessary, use a stiff wire with a hooked end to remove the packing and lantern ring (75) from the seal plate.

NOTE

An alternate method of removing the packing without disassembling the pump is to reach through the opening in the pedestal and remove the hardware and split packing gland. Use a stiff wire with a hooked end to remove the packing rings and lantern ring from the seal plate bore. Make sure all of the old packing is removed before installing the new packing.

Inspect the shaft sleeve (76) for nicks or scratches. Dress small nicks and burrs with a fine file or emery cloth. The shaft sleeve is secured by a shrink fit on the impeller shaft. If replacement is necessary, the sleeve must be uniformly heated and removed with a chisel. **Be careful** not to damage the impeller shaft.

If no further disassembly is required, see **Packing Installation**.

Shaft And Bearing Removal And Disassembly

When the pump is properly operated and maintained, the pedestal should not require disassembly. Disassemble the shaft and bearings **only** when there is evidence of wear or damage.

CAUTION

Shaft and bearing disassembly in the field is not recommended. These operations should be performed only in a properly-equipped shop by qualified personnel.

Remove the pedestal mounting hardware from the base. Tie and tag any shims under the mounting feet used for leveling.

Remove the pedestal drain plug (16) and drain the pedestal. Clean and reinstall the drain plug.

Remove the slinger ring (30).

Use snap ring pliers to remove the bearing retaining ring (21) from the pedestal bore. Remove the bearing shim set (22); tie and tag the shims, or measure and record their thickness for ease of reassembly.

MAINTENANCE AND REPAIR

Loosen the machine screws (80) in the bearing retainer (23), and pry the retainer from the pedestal bore using a screwdriver against the head of the machine screws.

Press the oil seal (20) from the bearing retainer, and remove the O-ring (69) from the pedestal bore.

Disengage the hardware (28 and 29) and remove the assembled bearing cover (13) and oil seal (26). Press the oil seal from the bearing cover.

Place a block of wood against the drive end of the shaft and tap the shaft and assembled bearings (14 and 24) out of the pedestal.

Use a bearing puller to remove the inboard and outboard bearings from the impeller shaft.

Shaft and Bearing Reassembly And Installation

Clean the pedestal, shaft and all component parts (except the bearings) with a soft cloth soaked in cleaning solvent. Inspect the parts for wear or damage and replace as necessary.

WARNING

```

////////////////////////////////////
//                               //
// Most cleaning solvents are toxic and flammable. Use //
// them only in a well-ventilated area free from excessive //
// heat, sparks, and flame. Read and follow all prec- //
// autions printed on solvent containers.                //
//                               //
////////////////////////////////////

```

Inspect the shaft for distortion, nicks or scratches or thread damage on the impeller end. Dress small nicks and burrs with a fine file or emery cloth. Replace the shaft if defective.

Clean the bearings thoroughly in **fresh** cleaning solvent. Dry the bearings with filtered compressed air and coat with light oil.

Rotate the bearings by hand to check for roughness or binding and inspect the bearing balls. If rotation is rough or the bearing balls are discolored, replace the bearings.

CAUTION

<p>Bearings must be kept free of all dirt and foreign material. Failure to do so will greatly shorten bearing life. DO NOT spin dry bearings. This may scratch the balls or races and cause premature bearing failure.</p>
--

The bearing tolerances provide a tight press fit onto the shaft and a snug slip fit into the pedestal. Replace the shaft or pedestal if the proper bearing fit is not achieved.

Lubricate the shaft with light oil and press the outboard bearing (24) onto the shaft until it seats squarely against the shaft shoulder.

CAUTION

When installing the bearings onto the shaft, NEVER press or hit against the outer race, balls, or ball cage. Press ONLY on the inner race.

Position the inboard bearing (24) on the shaft with the retaining ring facing toward the impeller end of the shaft. Press the bearing onto the shaft until it seats squarely against the shaft shoulder.

Slide the shaft and assembled bearings into the pedestal until the retaining ring on the inboard bearing seats against the pedestal.

CAUTION

When installing the shaft and bearings into the bearing bore, push against the outer race. NEVER hit the balls or ball cage.

Install the oil seal (26) in the bearing cover (13) with the lip positioned as shown in Figure 1. Apply a thin film of 'Loctite Plastic Gasket' or equivalent to the face of the bearing cover, and slide the bearing cover and oil seal over the shaft. Be careful not to damage the oil seal lip on the shaft threads. Secure the bearing cover with the hardware (28 and 29).

Install the oil seal (20) in the bearing retainer (23) with the lip positioned as shown in Figure 1. Replace the bearing retainer O-ring (69) in the pedestal, and press the bearing retainer into the pedestal until it seats against the bearing. Be careful not to cut the oil seal lip on the shaft keyway. **Be sure** the machine screws (80) are fully screwed into the bearing retainer, and that they are positioned horizontally inline.

Install the same thickness of bearing shims (22) as previously removed, and secure them with the retaining ring (21). Check the shaft endplay.

NOTE

Shaft endplay should be between .002 and .010 inch. Add or remove bearing adjusting shims to obtain this endplay.

Secure the pedestal to the base, and lubricate the bearings as indicated in **LUBRICATION**.

Packing Installation

(Figures 1 and 2)

Clean the bore of the seal plate, shaft sleeve and impeller shaft with a soft cloth soaked in cleaning solvent.

WARNING

```

////////////////////////////////////
//                               //
// Do not attempt to lift the complete pump unit using the //
// lifting eye. It is designed to facilitate removal or //
// installation of individual components only. Additional //
// weight may result in damage to the pump or failure of //
// the eye bolt.                               //
//                               //
////////////////////////////////////

```

Install the slinger ring (30) on the impeller shaft.

Lay the seal plate on a flat surface with the impeller side facing down, and temporarily center the shaft sleeve in the seal plate bore. If the shaft sleeve was not removed at disassembly, use a dowel or piece of tubing the same diameter as the sleeve to ease packing installation.

Install new packing rings into the seal bore as shown in Figure 2.

NOTE

It is recommended that replacement packing rings pre-cut to the correct width and length, and packaged in sets (see parts list), be ordered from The Gorman-Rupp Company or your Gorman-Rupp distributor. However, if bulk commercial packing will be used in this unit, prepare and install it in accordance with the steps outlined below in order to ensure that the packing will form a tight seal.

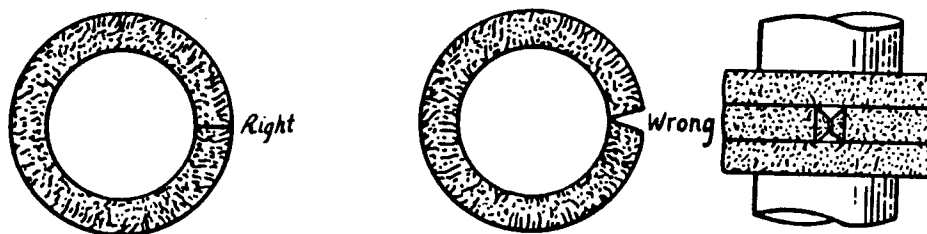

Step 1: Determine how much bulk packing will be required to fill the packing cavity, and wrap it around a rod of the same diameter as the shaft. With the packing wrapped around the rod, cut through each turn as shown.

If the cut rings are too thick and will not fit in the packing cavity, place each turn on a clean newspaper and use a length of pipe, as you would a rolling pin, to roll the ring until the thickness has been reduced. **Never** attempt to flatten a packing ring with a hammer.

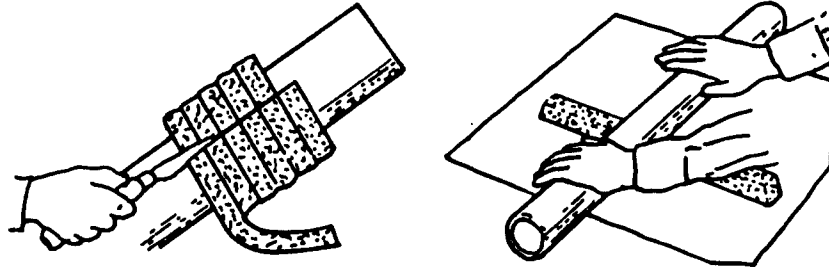

Step 2: It is critical that the ends of the cut packing rings meet in a tight parallel fit to ensure proper sealing. Check this fit; it should be correct if the packing was cut while wrapped around a rod, but if the packing was cut while laid out straight, the ends will meet at an angle. **Never** install a packing ring with an angled gap; pressure on adjacent packing rings will cause them to work into the gap and prevent the angled ring from closing properly around the shaft.

Some channel-type packing with a lead core may require a slight gap between packing ring ends to allow for expansion. Consult the packing manufacturer's installation instructions, and follow his recommendations.

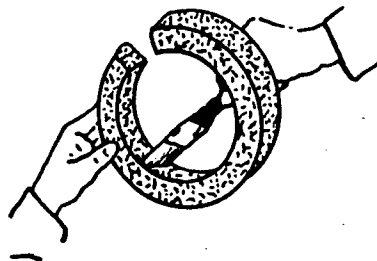

Step 3: Lubricate all metallic packings (foil type, lead core, etc.) with the lubricant recommended by the packing manufacturer. Generally, swabbing the inside diameter of this type packing with SAE No. 30 non-detergent oil provides sufficient lubrication.

MAINTENANCE AND REPAIR

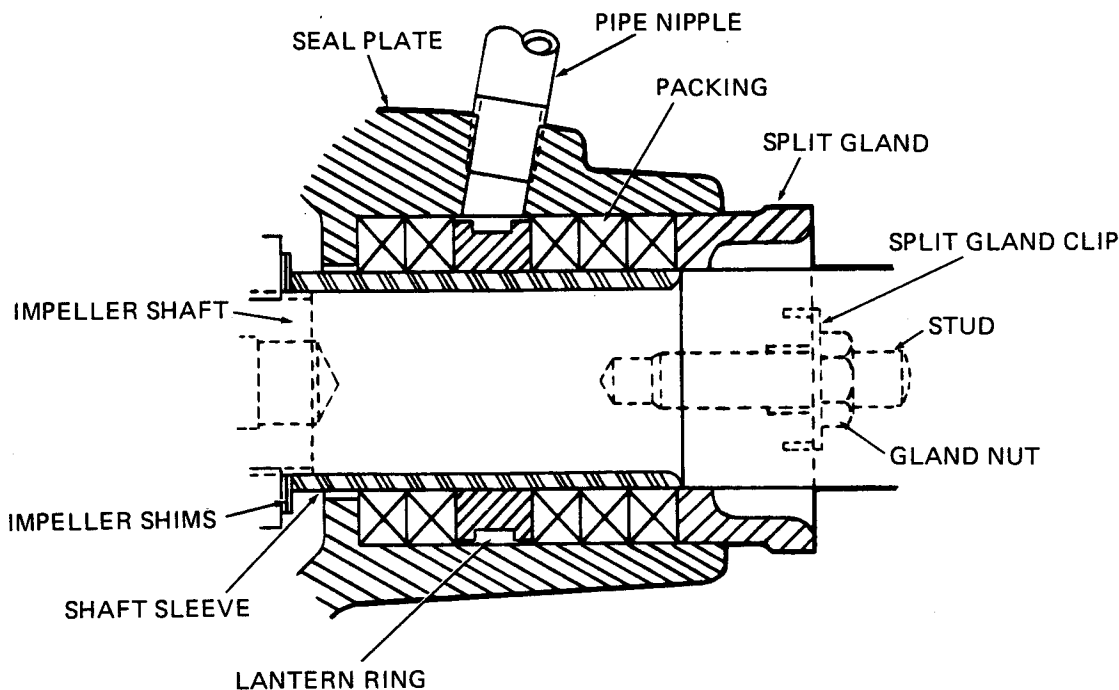

Figure 2. PP0624 1/2 Packing Seal Assembly

Dip the new packing rings in non-detergent oil before installation. Push each packing ring into the seal bore and compress it using a blunt ended sleeve (same diameter as packing gland) and mallet. Each successive layer must be compressed and rotated by 90° to prevent excessive leakage. **Be sure** the lantern ring is aligned with the lubrication port when the packing is fully compressed. Add enough packing to fill the seal plate to within 3/8 inch of the end.

Carefully slide the shaft sleeve, dowel or tube out of the packing.

If the shaft sleeve was removed, heat the replacement sleeve evenly and uniformly using an oil bath, oven or torch. **Quickly** slide the sleeve over the shaft until the chamfered end seats against the shaft shoulder. This operation must be done rapidly without allowing the sleeve to cool.

CAUTION

Do not allow the sleeve to hang up part way down the shaft. If this occurs, heat the sleeve enough to be removed, and repeat the uniform heating process. **DO NOT** try for force the sleeve onto the shaft. This can result in damage to the sleeve and/or shaft.

Position the assembled seal plate and packing rings on the impeller shaft and slide it on until the seal plate seats against the pedestal. Align the lubrication hole in the seal plate with the opening in the pedestal. Temporarily secure the seal plate to the pedestal using two capscrews and nuts (1/2 UNC X 1 1/2 inch long, not supplied).

Install the packing gland set in the seal plate and secure each half with the mounting hardware and gland clips. Draw up the deform locknuts evenly until they are snug, then back off the nuts until they just hold the packing gland set in position.

NOTE

Final packing adjustments should be made after the pump has been reassembled.

Reinstall the auxiliary lubrication piping (66, 67 and 68).

Impeller Installation

Inspect the impeller, and replace it if cracked or badly worn. Inspect the impeller and shaft threads for dirt or damage, and clean or dress the threads as required.

Install the same thickness of impeller shims (77) as previously removed, and screw the impeller on until tight.

A clearance of .020 to .040 inch between the impeller and the seal plate is necessary for maximum pump efficiency. Measure this clearance, and add or remove impeller shims until it is reached.

NOTE

The seal plate must be tight against the pedestal while setting the back impeller clearance.

Install the impeller capscrew and washer (36 and 37).

Pump Casing Installation

Remove the two capscrews temporarily securing the seal plate and install the same thickness of pump casing gaskets (34) as previously removed. Secure the pump casing to the seal plate and pedestal with the nuts (32). **Do not** fully tighten the nuts until the impeller face clearance has been set.

NOTE

If the pump has been completely disassembled, it is recommended that the back cover assembly be reinstalled at this point. The back cover assembly must be in place to adjust the impeller face clearance.

A clearance of .008 to .015 inch between the impeller and the wear plate is also recommended for maximum pump efficiency. This clearance must be set after installing the back cover, by adding or removing gaskets in the pump casing gasket set (34) until the impeller binds against the wear plate when the shaft is turned. After the impeller binds, add approximately .012 inch of gaskets.

NOTE

An alternate method of adjusting this clearance is to reach through the discharge port with a feeler gauge and measure the gap. Add or subtract pump casing gaskets accordingly.

When this clearance has been properly set, tighten the nuts (32) and secure the casing to the base with the previously removed hardware. Be sure to reinstall any leveling shims used under the casing mounting feet.

If a lifting eye was used to move the pump casing, **be sure** to remove the eye before putting the pump back into service.

WARNING

```

////////////////////////////////////
// Do not attempt to lift the complete pump unit using the //
// lifting eye. It is designed to facilitate removal or //
// installation of individual components only. Additional //
// weight may result in damage to the pump or failure of //
// the eye bolt. //
// //
////////////////////////////////////

```

Back Cover Installation

If the wear plate was removed for replacement, carefully center it on the back cover and secure it with the hardware (38 and 39). The wear plate must be concentric to prevent binding when the back cover is installed.

Replace the back cover gasket (41). Clean any debris from the contacting surfaces in the pump casing that might prevent a good seal with the back cover. Slide the back cover assembly into the pump casing. Secure the back cover assembly with the clamp bar (43) and clamp bar screw (42). **Do not** over-tighten the clamp bar screw; it should be just tight enough to ensure a good seal at the cover shoulder. Be sure the wear plate does not bind against the impeller.

Suction Check Valve Installation

Inspect the check valve components, and replace as required. Subassemble the check valve weights (60, 61 and 63) and gasket (62) using the attaching hardware (58 and 59).

Position the check valve in the check valve seat (64), and secure the check valve, valve seat, gaskets (65), and suction flange (49) in the suction port with the nuts (56).

Check the operation of the check valve to ensure proper seating and free movement.

Final Packing Adjustment

Start the pump and tighten the packing gland nuts evenly while the pump is operating. A slight flow of liquid through the packing (approximately 50 drops per minute) must be maintained for lubrication. Do not over-tighten the gland nuts and cut off this flow. After the gland has been adjusted, stop the pump. The shaft should rotate freely. If it does not, the gland is too tight.

If the old packing has been reinstalled and the flow of liquid through the packing cannot be controlled by adjusting the gland, the old packing must be replaced.

Final Pump Reassembly

Be sure the pump and pedestal are secure to the base and power source.

Install the suction and discharge lines and open all valves. Make certain that all piping connections are tight, properly supported and secure.

If a lifting eye was used to move the pump casing, **be sure** to remove the eye before putting the pump back into service.

WARNING

```

////////////////////////////////////
//                               //
// Do not attempt to lift the complete pump unit using the //
// lifting eye. It is designed to facilitate removal or //
// installation of individual components only. Additional //
// weight may result in damage to the pump or failure of //
// the eye bolt.                                           //
//                                                       //
////////////////////////////////////

```

Be sure the pump and power source have been properly lubricated, see LUBRICATION.

Fill the pump casing with clean liquid. Reinstall the fill plug and tighten it.

Refer to OPERATION, Section C, before putting the pump back into service.

LUBRICATION

Packing Assembly

The packing in the seal plate is lubricated by the liquid being pumped or by a flow of fresh liquid from an external source. When pumping clear liquids, prop-

er lubrication can be achieved by controlling the packing compression (**See Final Packing Adjustment**) to permit a slight flow of liquid through the packings.

When pumping non-lubricating liquids, fresh liquid should be supplied through the auxiliary piping in the seal plate (66, 67 and 68). Be sure the liquid supplied to the seal is compatible with the liquid being pumped, and that its flow is controlled to prevent dilution.

Bearings

The pedestal was fully lubricated when shipped from the factory. Check the oil level regularly through the sight gauge (79) and maintain it at the midpoint of the gauge. When lubrication is required, add SAE No. 30 non-detergent oil through the hole for the air vent (15). **Do not** over lubricate. Over-lubrication can cause the bearings to over-heat, resulting in premature bearing failure.

NOTE

The white reflector in the sight gauge must be positioned horizontally to provide proper drainage.

Under normal conditions, drain the pedestal once each year and refill with approximately 12 1/2 ounces of clean oil. Change the oil more frequently if the pump is operated continuously or installed in an environment with rapid temperature change.

CAUTION

Monitor the condition of the bearing lubricant regularly for evidence of rust or moisture condensation. This is especially important in areas where variable hot and cold temperatures are common.

For cold weather operation, consult the factory or a lubricant supplier for the recommended grade of oil.

Power Source

Refer to the literature accompanying the power source or contact your local power source representative for the manufacturer's recommendations.

**For U.S. and International Warranty Information,
Please Visit www.grpumps.com/warranty
or call:
U.S.: 419-755-1280
International: +1-419-755-1352**

**For Canadian Warranty Information,
Please Visit www.grcanada.com/warranty
or call:
519-631-2870**