SSERIES

INSTALLATION, OPERATION, PARTS LIST, AND MAINTENANCE MANUAL



THE GORMAN-RUPP COMPANY • MANSFIELD, OHIO
GORMAN-RUPP OF CANADA LIMITED • ST. THOMAS, ONTARIO, CANADA

Printed in U.S.A.

Copyright by the Gorman-Rupp Company

TABLE OF CONTENTS

INTRODUCTION	I-1
WARNINGS - SECTION A	A-1
INSTALLATION - SECTION B	B-1
PREINSTALLATION INSPECTION	B-1
Lubrication	B-2
PUMP INSTALLATION	B-2
Pump Specifications	B-2
Pump Dimensions	B-2
Lifting	B-3
Positioning The Pump	B-4
Piping	B-5
CONTROL BOX INSTALLATION	B-6
Enclosure	B-6
Dual Voltage Motor Wiring Instructions	B-6
Grounding Methods	B-10
Field Wiring Connections (Incoming Power)	B-11
Pump Power Cable Connections	B-12
LIQUID LEVEL DEVICES	B-13
OPERATION - SECTION C	C-1
CONTROL BOX FUNCTION	C-1
Component Function	C-1
PUMP OPERATION	C-2
Liquid Temperature And Overheating	C-2
Checking Pump Rotation	C-3
STARTING	C-4
Standard Pump (No Liquid Level Devices)	C-5
With Automatic Liquid Level Devices	C-5
STOPPING	C-5
Operation Checks	C-5
Cold Weather Preservation	C-6
TROUBLESHOOTING - SECTION D	D-1
TROUBLESHOOTING CHART	D-1
ELECTRICAL TESTING	D-4
Test Equipment	D-4
Voltage Imbalance	D-4
Motor And Motor Power Cable Continuity	D-5
Insulation Resistance	D-6
MAINTENANCE AND REPAIR - SECTION E	E-1
PERFORMANCE CURVE	E-1
PUMP MODEL - PARTS LIST	E-3
PUMP AND MOTOR DISASSEMBLY AND REASSEMBLY	E-4
PUMP END DISASSEMBLY	E-5
Strainer Disassembly	E-5
Draining Oil From Seal And Motor	E-5
Positioning Pump For Disassembly	E-5
Impeller Disassembly	E-6
Outer Seal Disassembly	E-6
Inner Seal Disassembly	E-7
PUMP END REASSEMBLY	E-7
Cleaning Old Parts	E-7
Inner Seal Reassembly	E-9
Outer Seal Reassembly	E-10
Impeller Reassembly	E-11
Diffuser, Wear Plate And Screen Reassembly	E-11
MOTOR DISASSEMBLY	E-12
Terminal Housing And Power Cable Disassembly	E-12

Pump Casing And Motor Housing Disassembly	E-13
Rotor And Stator Disassembly	E-13
Relief Valve	E-14
Hoisting Bail	E-15
MOTOR REASSEMBLY	E-15
Stator Reassembly	E-15
Rotor Assembly	E-16
Terminal Housing And Power Cable Reassembly	E-18
LUBRICATION	E-19
Motor End Seal Cavity	E-19
Motor Housing Cavity	E-20
FINAL ASSEMBLY	E-20

INTRODUCTION

This Installation, Operation, and Maintenance Manual is designed to help you achieve the best performance and longest life from your Gorman-Rupp pump.

This pump is designed to operate fully or partially submerged. It is capable of handling most nonvolatile and nonflammable liquids which are mildly corrosive and abrasive. The basic material of construction is aluminum with ductile iron or steel wearing parts. The integral dual voltage electric motor must be operated through the control box furnished with the pump. Neither the pump motor nor control box are explosion proof and should not be operated in a hazardous atmosphere.

If there are any questions regarding the pump or motor which are not covered in this manual or in other literature accompanying this unit, please contact your Gorman-Rupp distributor or the Gorman-Rupp Company:

The Gorman-Rupp Company	or	Gorman-Rupp of Canada Limited
P.O. Box 1217		70 Burwell Road
Mansfield, Ohio 44901		St. Thomas, Ontario N5P 3R7

The following are used to alert maintenance personnel to procedures which require special attention, to those which could damage equipment, and to those which could be dangerous to personnel:

NOTE

Instructions to aid in installation, operation, and maintenance or which clarify a procedure.

CAUTION

Instructions which must be followed to avoid causing damage to the product or other equipment incidental to the installation. These instructions describe the requirements and the possible damage which could result from failure to follow the procedures.

WARNING

```

////////////////////////////////////
//                               //
// These instructions must be followed to avoid causing in- //
// jury or death to personnel, and describe the procedure //
// required and the injury which could result from failure //
// to follow the procedure. //
//                               //
////////////////////////////////////

```

WARNINGS

WARNINGS - SECTION A

THESE WARNINGS APPLY TO THE "S-SERIES" SUBMERSIBLE MOTOR OPERATED PUMPS.

WARNING

```

////////////////////////////////////
//
// Before attempting to open or service the pump:
//
// 1. Familiarize yourself with this manual.
// 2. Lock out the motor to the control panel to ensure
//    that the pump will remain inoperative.
// 3. Allow the pump to cool if overheated.
// 4. Close the discharge valve (if used).
//
////////////////////////////////////

```

WARNING

```

////////////////////////////////////
//
// Do not attempt to pump volatile or flammable liquids for
// which this pump has not been designed.
//
////////////////////////////////////

```

WARNING

```

////////////////////////////////////
//
// Before connecting any cable to the control box, be sure
// to ground the control box. See Figure 5 on page B-10
// for suggested grounds.
//
////////////////////////////////////

```

WARNING

```

////////////////////////////////////
//
// After the pump has been installed, make certain that the
// pump and all piping or hose connections are secure be-
// fore operation.
//
////////////////////////////////////

```

WARNING

```

////////////////////////////////////
//
// The pump motor is designed to be operated through the
// control box furnished with the pump. The control box
// provides overload protection and power control. Do not
// connect the pump motor directly to the incoming power
// lines.
//
////////////////////////////////////

```

WARNINGS

WARNING

```

////////////////////////////////////
//
// All electrical connections must be in accordance with //
// the National Electric Code and all local codes. If //
// there is a conflict between the instructions provided //
// and N.E.C. specifications, N.E.C. specifications shall //
// take precedence. All electrical equipment supplied with //
// this pump was in conformance with N.E.C. requirements in //
// effect on the date of manufacture. Failure to follow //
// applicable specifications, or substitution of electrical //
// parts not supplied or approved by the manufacturer, can //
// result in severe injury or death. //
//
////////////////////////////////////

```

WARNING

```

////////////////////////////////////
//
// The electrical power used to operate this pump is high //
// enough to cause injury or death. Make certain that the //
// control box is grounded, and that the power supply is //
// compatible with the motor phase and voltage, before con- //
// necting the power source. If the overload unit is //
// tripped during pump operation, correct the problem be- //
// fore restarting the pump. //
//
////////////////////////////////////

```

WARNING

```

////////////////////////////////////
//
// Obtain the services of a qualified electrician to con- //
// nect the electrical circuits, and to service the control //
// box. //
//
////////////////////////////////////

```

WARNING

```

////////////////////////////////////
//
// Do not attempt to lift the pump by the motor power cable //
// or the piping. Attach proper lifting equipment to the //
// hoisting bail fitted to the pump. //
//
////////////////////////////////////

```

INSTALLATION - SECTION B

This section is intended only to summarize recommended installation practices for the pump and control box. If there are any questions concerning your specific installation, contact your Gorman-Rupp distributor or the Gorman-Rupp Company.

Automatic liquid level devices are not furnished with the standard pump, but are available from Gorman-Rupp as options (see **Liquid Level Devices**, Section B); for information on installing and operating these devices, see the technical data accompanying that option.

PREINSTALLATION INSPECTION

The pump assembly and control box were inspected and tested before shipment from the factory. Before installation, check for damage which may have occurred during shipment. Check as follows:

- a. Check the pump assembly for cracks, dents, damaged threads, and other obvious damage.
- b. Check for and tighten loose bolts, nuts, capscrews, and other attaching hardware. Since gaskets tend to shrink after drying, check for and tighten loose hardware securing all mating surfaces.
- c. The standard pump is connected to the control box with 50 ft. of power cable. Inspect the cable for cuts or damage.
- d. Check the control box for cracks, dents, and other obvious damage.
- e. Check that all control box components are securely attached to their mounting surfaces, and that the electrical connections are tight and free of corrosion.
- f. Compare the amperes, phase, voltage, and hertz indicated on the motor name plate to the ratings indicated for the control box.
- g. Carefully read all tags, decals, and markings on the pump assembly and the control box, and perform all duties indicated.
- h. Check the pump and motor for any oil leaks. An oil leak may indicate a cut O-ring or other damage.
- i. If the pump and control box have been stored for more than 12 months, some of the components or lubricants may have exceeded their maximum shelf life. These **must be inspected or replaced** to insure maximum pump service.

If the maximum shelf life has been exceeded, or if anything appears to be abnormal, contact your Gorman-Rupp distributor or the factory to determine the repair or updating policy. **Do not** put the pump into service until appropriate action has been taken.

INSTALLATION

Lubrication

There are two lubrication cavities in this pump, both contain a premium quality hydraulic oil. The motor housing cavity provides lubrication to the motor assembly and rotor shaft bearings. The intermediate cavity provides lubrication to the seal assembly.

There are two shaft seals in this pump. The lower seal prevents liquid from entering the intermediate cavity at the impeller end. The upper seal prevents oil leakage from the motor housing cavity and acts as back-up protection in the event of lower seal failure.

Both lubrication cavities are fully lubricated when the pump is shipped from the factory. Check lubrication levels before installing the pump (see **LUBRICATION** in **MAINTENANCE AND REPAIR**). An additional quart of hydraulic oil has been provided with the pump to "top off" the oil cavities. If either oil level is abnormally low, determine the cause before putting the pump into service.

PUMP INSTALLATION**Pump Specifications**

See Table 1 for the typical pump specifications and motor data.

Table 1. Pump Specifications

Model Number	Voltage/Phase	Pump Horse-power	Motor Speed (RPM)	Full Load Amperes	No Load Amperes	Locked Rotor Amperes	Discharge Size (NPT)
S4D1	230/3	10	3450	34	7	148	4
S4D1	460/3	10	3450	17	3.5	74	4

Pump Dimensions

The standard pump is provided with a suction strainer to prevent large solids from clogging the impeller. On high discharge head applications, the strainer can be replaced with an optional staging adaptor to allow one pump to feed another.

See Figure 1 on page B-3 for the approximate physical dimensions of the pump.

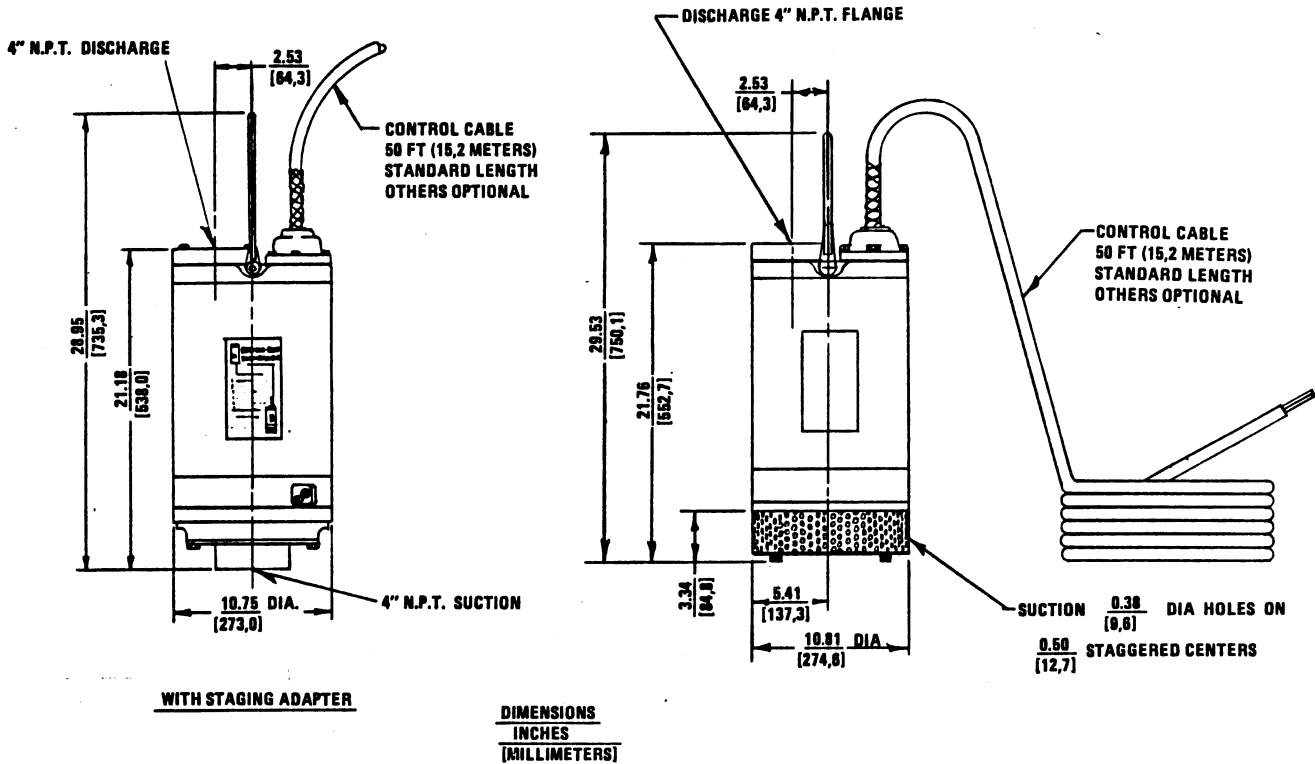

Figure 1. Pump Model S4D1-460V 3P

Lifting

Use lifting equipment with a capacity of a least **1,000 pounds**. This pump weighs approximately **190 pounds**, not including the weight of accessories and control box. Customer installed equipment such as rigid piping **must** be removed before attempting to lift.

WARNING

```

////////////////////////////////////
//
// Do not attempt to lift the pump by the motor power cable //
// or the piping. Attach proper lifting equipment to the //
// hoisting bail fitted to the pump. If chains or cable //
// are wrapped around the pump to lift it, make certain //
// that they are positioned so as not to damage pump, and //
// so that the load will be balanced. //
// //
////////////////////////////////////

```

Positioning The Pump

This pump is designed to operate fully or partially submerged. It may also be operated in air for extended periods. The rotating parts are oil lubricated, and the motor is cooled by a constant flow of liquid or air discharged through internal passage(s).

The pump will operate if positioned on its side, but this is not recommended because the motor torque could cause the pump to roll during operation.

The pump should be independently secured and supported by the hoisting bail. If the application involves a lot of debris, protect the pump from excessive wear and clogging by suspending it in a perforated barrel or culvert pipe. If the bottom is heavily sludge-covered, rest the pump on support blocks or suspend it from a raft or similar device near the surface of the liquid. See Figure 2 on page B-5 for typical pump installations.

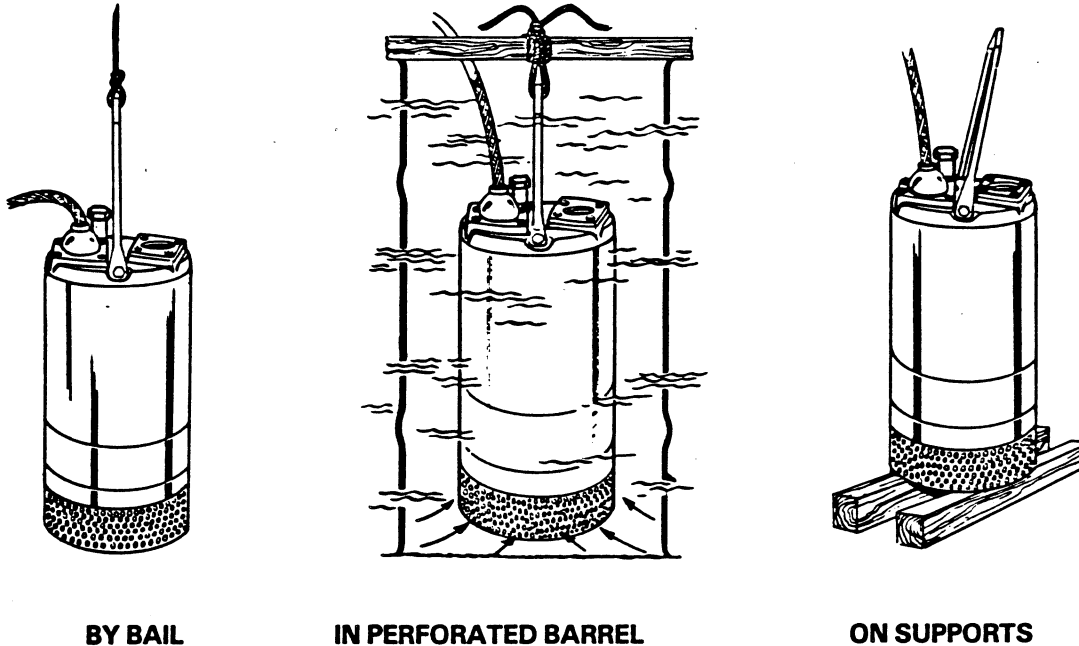

Figure 2. Typical Pump Installations.

All liquid entering the pump must pass through a strainer screen. Any spherical solids which pass through the screen will pass through the pump.

NOTE

Before actual operation, check the direction of impeller rotation to ensure that the pump is properly wired to the control box. See **Checking Pump Rotation in OPERATION** section.

Piping

No suction piping is required in a standard submersed application.

If an optional suction staging adaptor is installed, the discharge from one pump may be piped to the suction of another. To determine the size of the discharge connection, see Table 1, PUMP SPECIFICATIONS. Either hose or rigid pipe may be used. To facilitate mobility and maintenance, it is recommended that the discharge line be fitted with a quick disconnect fitting near the pump. The discharge line must be independently supported to avoid strain and vibration on the pump.

INSTALLATION

For maximum pumping capacity, keep the discharge as short and straight as possible. Minimize the use of elbows and fittings which increase friction losses through the discharge piping system.

It is recommended that a check valve or throttling valve be installed in the discharge line to control siphoning or back flow when the pump is shut off.

CONTROL BOX INSTALLATION

This pump is driven by an integral 460 VAC, 60 hertz, 3 phase, 10 HP motor. It is designed to operate through the control box furnished with the pump.

WARNING

Warning text enclosed in a box of slashes: // The pump motor is designed to be operated through the control box furnished with the pump. The control box provides overload protection and power control. Do not connect the pump motor directly to the incoming power lines.

Enclosure

The control box is a rainproof enclosure with a padlockable front cover. The enclosure is not designed to be watertight, and should not be submerged. See Figure 4 on page B-8 for enclosure dimensions and callouts.

Dual Voltage Motor Wiring Instructions

This pump is powered by a dual voltage motor which permits utilization of high or low voltage. The motor was originally wired and shipped for the voltage indicated as "Factory Wired" on the pump's name plate. The name plate also indicates the dual voltages pertaining to this motor. If the alternate voltage must be utilized, certain wiring and control box modifications are required.

The control box assembly provided with this pump has been designed to accommodate only the voltage indicated on the front of the box. This voltage coincides with the "Factory Wired" voltage of the motor. If the alternate voltage is utilized, the control box must be replaced with another box designed for the appropriate voltage. Consult the Parts List under Options (Section E, Page 3) to determine the part number of the alternate voltage control box.

The wiring inside the terminal housing, which is located on top of the pump, must also be changed. For detailed instructions on disassembly and reassembly of the terminal housing, see Terminal Housing and Power Cable Disassembly and Terminal Housing and Power Cable Reassembly in this manual (Section E). Change the motor lead and pump power cable wiring as indicated on the wiring diagram plate affixed to the side of the terminal housing, see Figure 3 on page B-7. Be sure to tag the revised voltage on the pump.

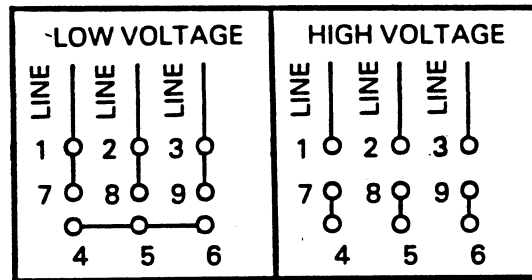

Figure 3. Motor Wiring Diagram

Secure the control box vertically on a level surface, which is above flood level. It should be easily accessible to the operator, and located close enough to the pump to avoid excessive voltage drop due to cable length. (See **Pump Power Cable Connections**). After the box is installed, make certain the front cover latches properly.

CAUTION

Failure to mount the control box vertically on a level surface may affect operation of the pump controls.

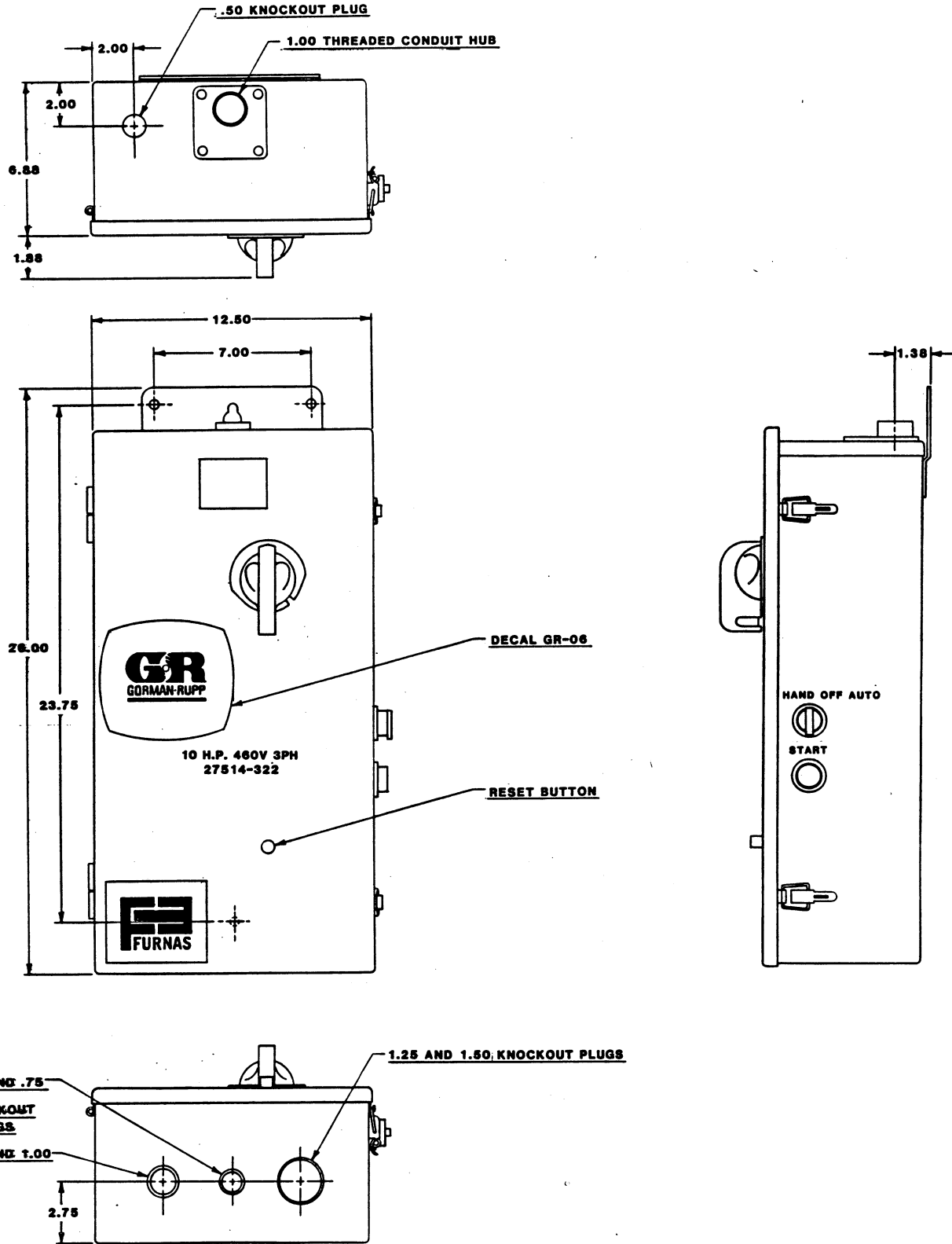
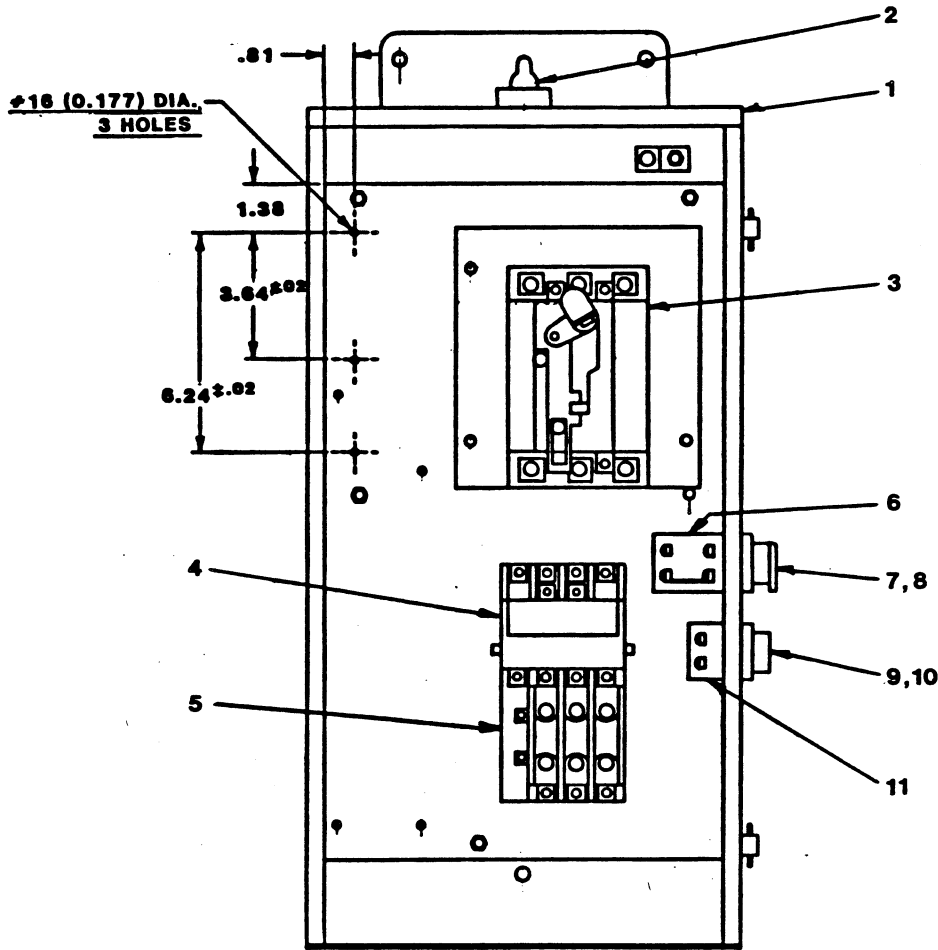

Figure 4. 27514-322 Control Box Assembly

PARTS LIST 27514-322 CONTROL BOX ASSEMBLY



(Repair Components Identified By Vendor Part Number)

ITEM NO.	PART NAME	PART NUMBER	PRIME VENDOR	QTY
1	ENCLOSURE	NEMA-3	FURNAS	1
2	HUB PIPE FITTING, 1"	-----	FURNAS	1
3	CIRCUIT BREAKER (SET ON 3)	TEC-36030	G-E	1
4	MOTOR STARTER, SIZE 1	14DF32AC-81	FURNAS	1
5	HEATER	K-57	FURNAS	3
6	CONTACT BLOCK	52-B-AA	FURNAS	1
7	SELECTOR SWITCH - 3 POSITION	52-SB-2CAB	FURNAS	1
8	NAME PLATE, HAND-OFF-AUTO	D11806001	HOOVER	1
9	START SWITCH	52-RA-1A1	FURNAS	1
10	NAME PLATE - START	D11804003	HOOVER	1
11	CONTACT BLOCK	52-BAK	FURNAS	1
NOT SHOWN:				
	OVERLOAD RESET BUTTON	49D52209-1	FURNAS	1
	WIRING DIAGRAM	0087A	HOOVER	1
	DECAL	GR-06	G-R	1

Grounding Methods

Electrically ground the installation before connecting the field wiring to the control box. Install a grounding terminal to the enclosure and connect it to a properly imbedded electrode.

The material used for the electrode **must** be an excellent conductor of electricity, such as copper. If iron or steel is used, it must be galvanized or otherwise metal plated to resist corrosion. **Do not** coat the electrode with any material of poor conductivity such as paint or plastic.

The electrode must conform to the recommendations of N. E. C. Article 250. Follow all installation requirements of the N.E.C., and all applicable local codes. See Figure 5 for some suggested grounding methods.

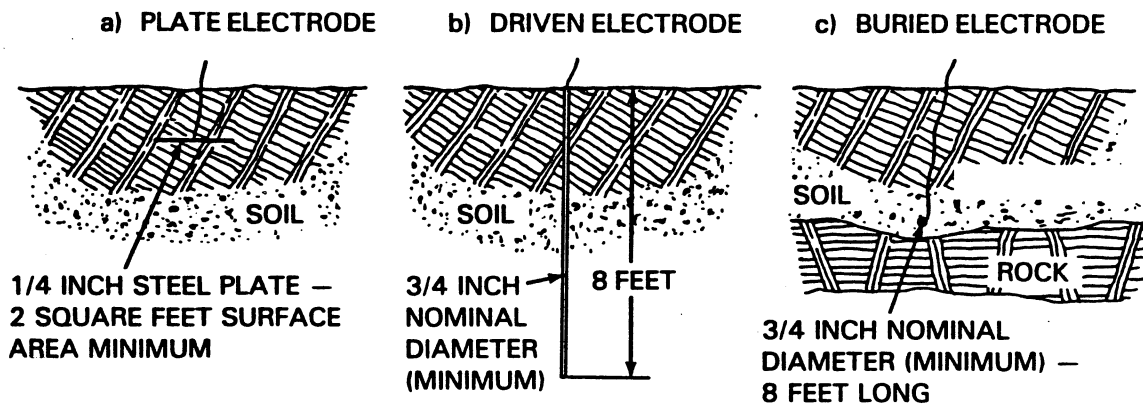

Figure 5. Suggested Grounding Methods

- a. **Plate Electrode:** An iron or steel plate, 1/4 inch thick, completely imbedded in the ground. The plate must present a surface of a least 2 square feet.
- b. **Driven Electrode:** A rod or pipe, 3/4 inch diameter minimum, 8 feet long, completely driven into the ground.
- c. **Buried Electrode:** If rock or stone prevents imbedding the full 8-foot length of the ground rod, bury it in a horizontal trench.

Space the ground rod or plates at least 6-feet from any other electrode or ground rod, such as those used for signal circuits, radio grounds, lightning rods, etc.

The earth surrounding the ground rod or plate **must** contain enough moisture to make a good electrical connection. In dry or sandy areas, pour water around the rod or consult qualified personnel to devise a method of improving the connection.

WARNING

```

////////////////////////////////////
//
// The electrical power used to operate this pump is high //
// enough to cause injury or death. Make certain that the //
// control box is properly grounded after installation. //
//
////////////////////////////////////

```

Field Wiring Connections (Incoming Power)

WARNING

```

////////////////////////////////////
//
// The electrical power used to operate this pump is high //
// enough to cause injury or death. Obtain the services of //
// a qualified electrician to make all electrical con- //
// nections. Make certain that the pump and enclosure are //
// properly grounded, and that the incoming power matches //
// the requirements of the pump and control. //
//
////////////////////////////////////

```

The pump control is designed to regulate a 460 volt, 3 phase, 60 hertz power supply. The field wiring must be properly sized to insure an adequate voltage supply. The voltage available at the motor must be within the range indicated in Table 2.

To calculate the voltage available at the motor proceed as follows:

- a. Measure the incoming voltage across lines (1 & 2, 2 & 3, and 1 & 3.) while the pump is **operating at full capacity**. See Figure 7 on page B-15 or Figure 8 on page B-16.
- b. Next, subtract the motor cable voltage drop (see Table 3, Motor Cable Specifications).
- c. Do not continue to operate the pump if this voltage is not within the recommended limits. Obtain the services of a qualified electrician to determine the correct field wiring size and other details to insure an adequate voltage supply to the pump.

Table 2. Pump Motor Voltage Limits

Nominal Voltage	Phase	Minimum Voltage	Maximum Voltage
230	3	210	250
460	3	420	500

INSTALLATION

Use conduit or cable clamps to secure the incoming field wiring to the control box. Make certain all connections are tight and that cable entry points are rainproof. Support the cable weight, if required, to prevent excessive strain on cable clamps and cable.

Pump Power Cable Connections

WARNING

```

////////////////////////////////////
//
// The electrical power used to operate this pump is high //
// enough to cause injury or death. Make certain that in- //
// coming power is OFF and LOCKED OUT before connecting //
// power or accessory cables to the control box. Obtain //
// the services of a qualified electrician to make all //
// electrical connections. //
// //
////////////////////////////////////
    
```

The standard pump is provided with a 50-foot power cable, factory wired into the control box. (See Table 3 for cable specifications.). If a longer power cable is required, an optional cable assembly **must** be ordered from the factory. Splicing of the power cable is **not** recommended by the Gorman-Rupp Company due to safety and warranty considerations.

WARNING

```

////////////////////////////////////
//
// Never attempt to alter the length or repair any power //
// cable with a splice. The pump motor and cable must be //
// completely waterproof. Injury or death may result from //
// alterations. //
// //
////////////////////////////////////
    
```

Table 3. Cable Requirements for Pump Electrical Connections, Model S4D1

Voltage/ Phase	A.W.G. Cable Size	Cable OD (inches)	Conductor Dia. (inches)	Amp Rating* at 40°C (amperes)	DC Resist- ance at 25°C (ohms/ 1000 ft)	Voltage Drop at Max. Load per 100 ft
230/3	8	0.91	0.17	59	0.71	4.85
460/3	8	0.91	0.17	59	0.71	2.42

*Applies only to GGC type cable. Refer to manufacturer's specifications for other cable.

Before connecting the pump power cable to the control box, make certain the incoming power is **OFF** and **LOCKED OUT**. Make certain the control box is **PROPERLY GROUNDED** and that the electrical data on the control matches the motor name plate data.

Connect the pump power cable to the control box as shown in Figure 7 on page B-15 or Figure 8 on page B-16. Use conduit or cable clamps to secure the power and accessory cables to the control box. Make certain that all connections are tight and that cable entry points are rainproof.

NOTE

The power cable furnished with this pump includes three electrical conductors (white, red, and black), two grounding conductors (green) and one ground check conductor (yellow). The yellow ground check lead is used in conjunction with customer supplied ground monitoring equipment. If this equipment is not used, the yellow lead should be connected with the green leads and used as a ground conductor.

LIQUID LEVEL DEVICES

The standard pump is **not** furnished with a means to automatically regulate liquid level. However, the pump may be controlled to perform filling, or dewatering functions by using **either** of the following optional sensing devices: (see Figure 6 on page B-14.

- **Diaphragm Type:** two fixed position sensors (upper and lower) each contain a diaphragm which flexes with changes in liquid level, thus activating an enclosed miniature switch.
- **Bulb (Float) Type:** a bulb raises or lowers (floats) with the liquid level, thus activating an enclosed miniature switch.

For added safety, the sensing devices operate through low voltage (24 volt) circuitry which is specially designed to fit into the main pump control box.

The circuitry may be prewired as a factory option, or easily added in the field by qualified personnel. For installation and operation, see the detailed instructions included with the optional package.

TYPICAL ILLUSTRATION

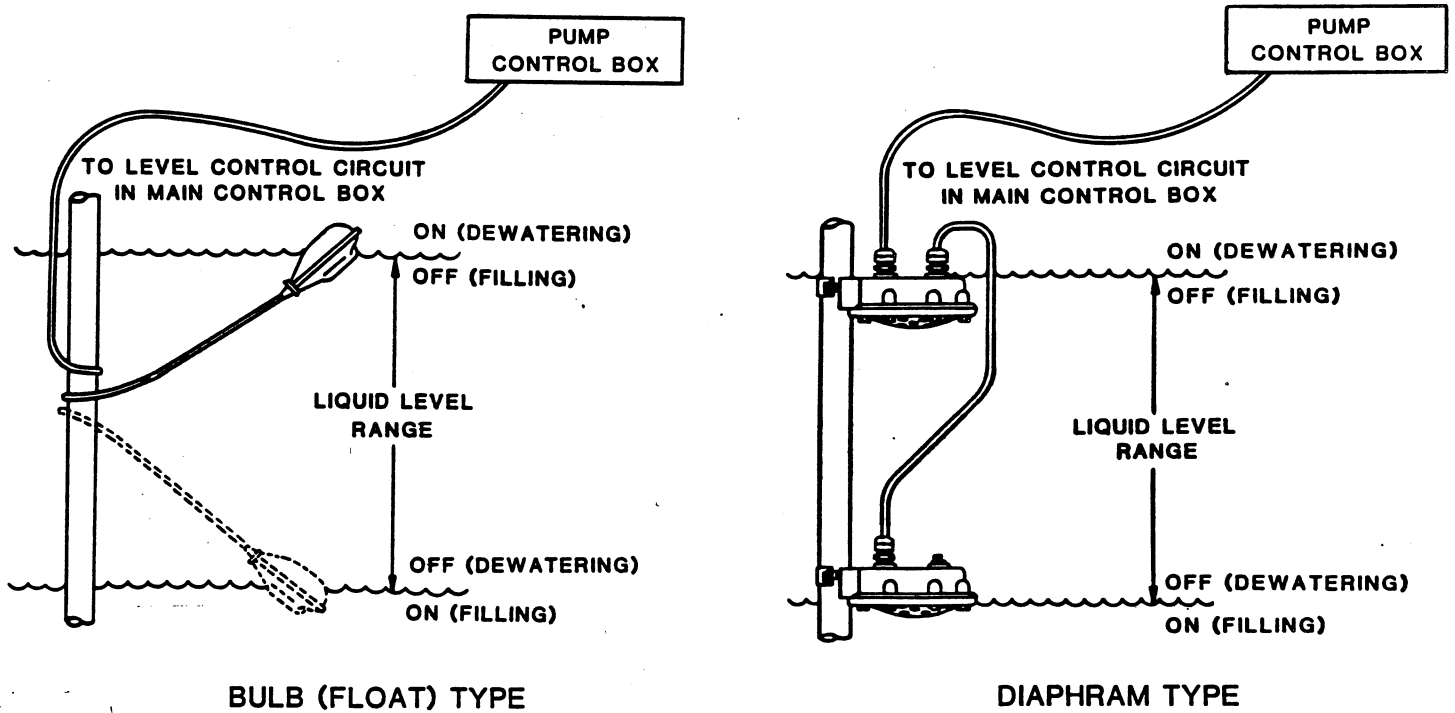

Figure 6. Liquid Level Devices

CAUTION

The internal wiring of the sensing devices are different for filling and dewatering functions. Be sure to follow the instructions included with the option before making wiring connections.

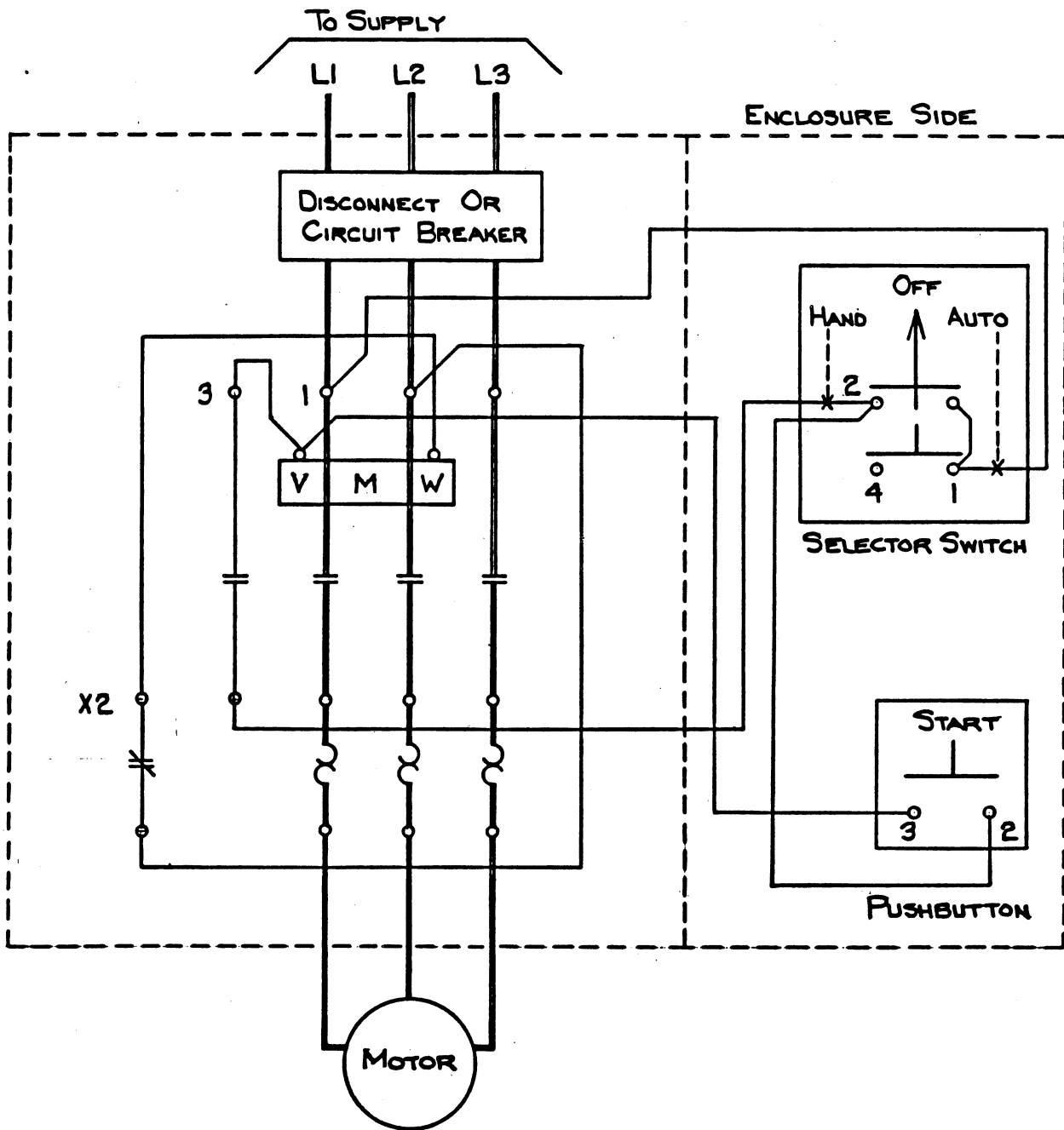

Figure 7. Control Box Wiring Diagram (Without Liquid Level Controls)

See Figure 8 on page B-16 for a wiring diagram including liquid level controls.

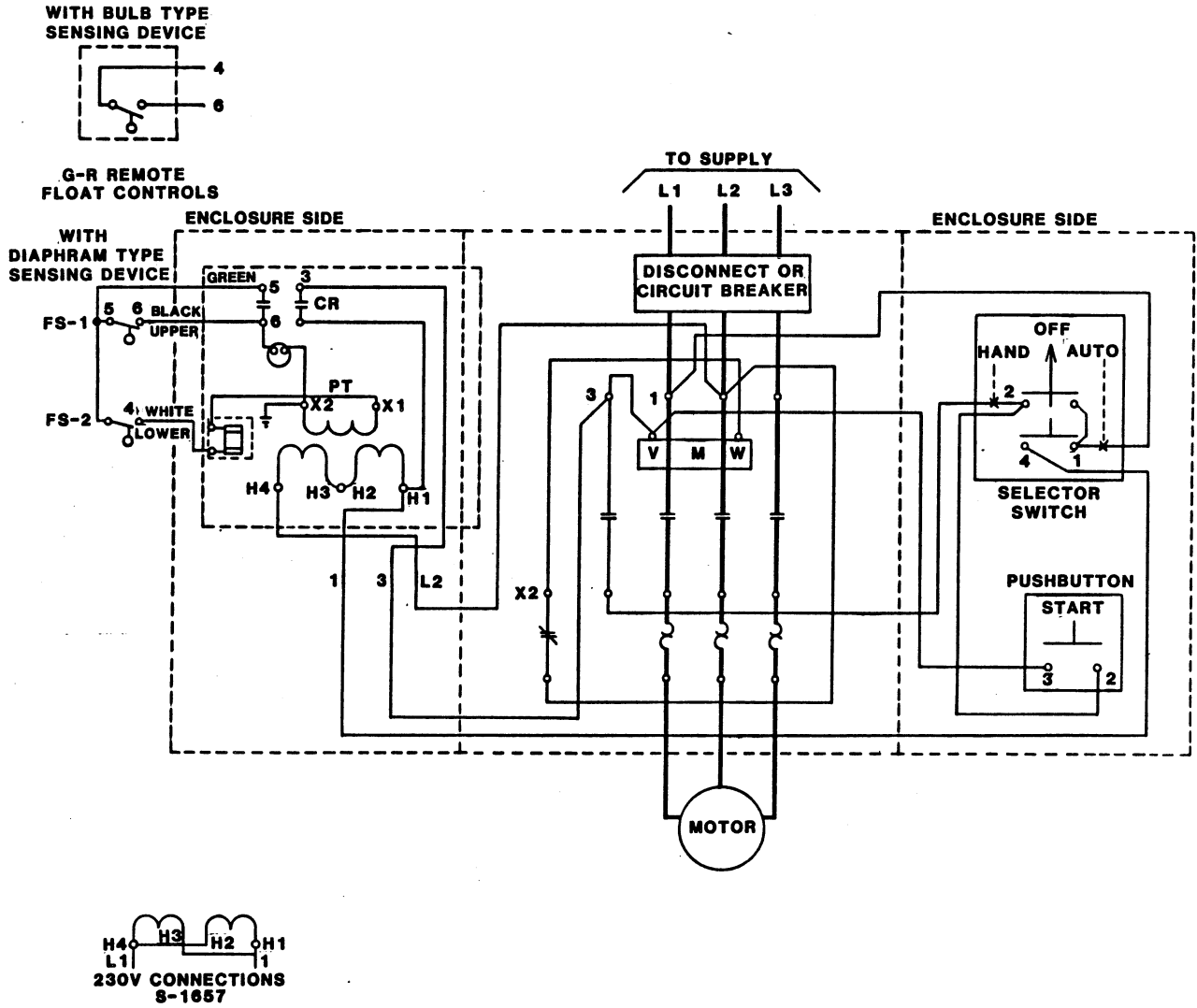

Figure 8. Control Box Wiring Diagram (With Liquid Level Controls)

OPERATION - SECTION C

CONTROL BOX FUNCTION

WARNING

```

////////////////////////////////////
//
// This pump motor and control box are not designed to be //
// explosion proof. Do not operate in an explosive atmos- //
// phere. //
// //
////////////////////////////////////

```

A control box is provided to facilitate operation of the pump. It contains controls for starting and stopping the pump, and provides overload protection for the pump motor. The pump control may be equipped with an optional automatic liquid level sensing device, in which case the low voltage circuits are also contained within the control box.

WARNING

```

////////////////////////////////////
//
// The pump motor is designed to be operated through the //
// control box furnished with the pump. The control box //
// provides overload protection and power control. Do not //
// connect the pump motor directly to the incoming power //
// lines. //
// //
////////////////////////////////////

```

CAUTION

Since operation of the pump motor is dependent upon the quality and performance of the electrical controls, the pump warranty is valid only when controls have been specified or provided by the Gorman-Rupp Company.

Component Function

The control box contains the following hand operated switches and controls:

- The **control handle** operates the control box circuit breakers. In the OFF position, the control handle opens the circuit breakers to interrupt incoming power through the control box and prevent pump operation. In the ON position, it closes the circuit breakers to permit pump operation. The circuit breakers will open or "TRIP" automatically in the event of a short circuit overload current, or thermal excess within the pump motor or electrical system. When tripped, move the control handle to OFF and back to ON to reset the circuit breakers.

OPERATION

- The **selector switch** (optional on some boxes) controls the mode of operation. In the OFF position, it prevents all operation of the pump. In the HAND position, it allows the pump to run continuously. In the AUTO position, it allows the pump to be controlled automatically by the optional liquid level control system, if used.
- The **RESET** pushbutton resets the motor overload relay after it has been "TRIPPED" by an overload. The overload relay will trip automatically if the current drawn by the motor exceeds design specifications.

NOTE

If the overload unit trips, do not reset it immediately. Wait at least ten minutes before resetting the control handle back to the ON position. If the overload unit continues to trip, operational problems exist. See **TROUBLESHOOTING**.

WARNING

```

////////////////////////////////////
//
// The motor will restart as soon as the RESET pushbutton //
// is pressed, unless the selector switch is in the OFF po- //
// sition. Turn the selector switch to OFF and move the //
// control handle to OFF before approaching the pump. //
//
////////////////////////////////////

```

- The **liquid level devices** (optional equipment) operate in conjunction with the 3-position switch (HAND-OFF-AUTO) supplied as a part of that option. After the level sensors and circuitry have been installed, pump operation may be automatically controlled for filling or dewatering functions. (See **LIQUID LEVEL DEVICES**, Section B.)

PUMP OPERATION

WARNING

```

////////////////////////////////////
//
// This pump is designed to pump most nonvolatile and //
// nonflammable liquids which may be mildly corrosive or //
// abrasive Do not attempt to pump liquids which may dam- //
// age the pump or endanger personnel as a result of pump //
// failure. //
//
////////////////////////////////////

```

Liquid Temperature And Overheating

The **maximum** liquid temperature for this pump is 120° F.. Do not apply it at a higher operating temperature.

OPERATION

Overheating can occur if the pump is misapplied, or if the control box fails to provide adequate protection. Operating the pump against a closed discharge for extended period will also cause the pump to overheat.

As a safeguard against rupture or explosion due to heat, this pump is equipped with a pressure relief valve which will open if vapor pressure within the pump motor reaches a critical point. If overheating does occur, stop the pump immediately and allow it to cool before servicing it. **Approach any overheated pump cautiously.**

WARNING

```

////////////////////////////////////
//                               //
// Overheated pumps can cause severe burns and injury. If //
// overheating of the pump occurs:                               //
//                               //
// 1. Stop the pump immediately.                               //
// 2. Allow the pump to cool.                                   //
// 3. Refer to instructions in this manual before re- //
// starting the pump.                                           //
//                               //
////////////////////////////////////

```

It is recommended that the pressure relief valve assembly be replaced at each overhaul, or any time the pump motor overheats and activates the valve. **Never** replace this valve with a substitute which has not been specified or provided by the Gorman-Rupp Company.

Checking Pump Rotation

Check the direction of pump rotation before operation to ensure that the impeller is rotating in the correct direction.

Suspend the pump from the hoisting bail. Turn it on momentarily and note the direction of twist. For correct rotation and operation, the twist must be in the **counterclockwise** direction when viewed from the **top**.

CAUTION

<p>Secure the pump during rotation check to prevent coiling of the power cable.</p>

OPERATION

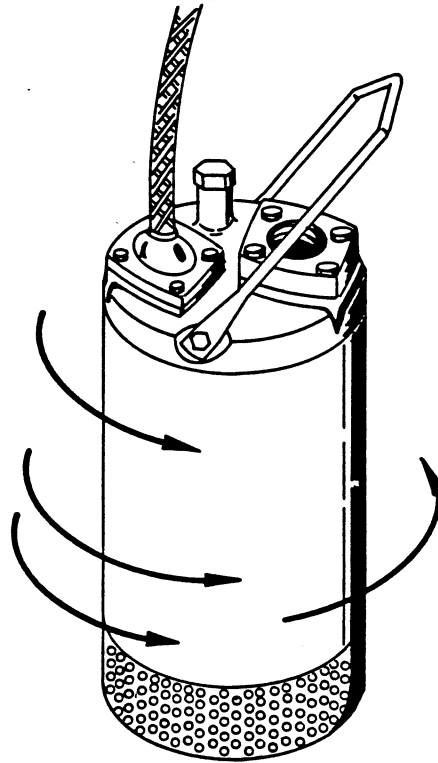

Figure 1. Checking Pump Rotation

If the pump twists clockwise on start, interchange any two motor leads at the control box.

WARNING

```

////////////////////////////////////
// The electrical power used to operate this pump is high //
// enough to cause injury or death. Make certain that in- //
// coming power is OFF and LOCKED OUT before interchanging //
// motor leads. //
////////////////////////////////////

```

STARTING

After the pump and control box have been installed, start the pump as follows.

NOTE

Before actual operation, check the direction of impeller rotation to ensure that the pump is properly wired. See **Checking Pump Rotation** in **OPERATION** section.

OPERATION

Standard Pump (No Liquid Level Devices)

If no liquid level devices have been installed, move the control handle to the ON position and turn the selector switch to HAND. The pump motor will start and pumping should begin.

The pump will continue to operate until it is stopped by turning the selector switch to OFF.

With Automatic Liquid Level Devices

If optional liquid level devices have been installed, move the 3-position selector switch to OFF and the control handle to the ON position.

If desired to operate the pump in the manual mode, set the selector switch to HAND; the pump will continue to run until the switch is returned to OFF, or reset to AUTO.

If desired to operate the pump in the automatic mode, set the selector switch to AUTO; pump operation will be maintained by the optional liquid level control system. To terminate automatic mode, move the selector switch to OFF or HAND.

STOPPING

To stop pump operation, turn the control handle OFF.

Power going to the pump from the control box is terminated by moving the control handle to the OFF position, thereby opening the circuit breakers. This **does not** terminate incoming power through the field wiring connected to the control box.

After stopping the pump, be sure to perform all required maintenance and preservation procedures.

NOTE

It is recommended that a check valve or throttling valve be installed in the discharge line if there is any possibility of siphoning or back flow when the pump is shut off.

Operation Checks

Check the pump for proper operation when it is first started and periodically thereafter to identify minor problems.

Check the pump for unusual noises or excessive vibration while it is operating. If noise or vibration is excessive, stop the pump and refer to the troubleshooting chart for possible causes.

Check the pump strainer screen for clogging caused by stones, sticks, or other debris. Clean the strainer screen when required. In some cases, stopping the

OPERATION

pump momentarily may back flush the strainer screen, purging most of the debris from it. If this fails to clean the screen, remove the pump from the sump and remove the debris manually. See PUMP DISASSEMBLY.

Check the pump for overheating. The pump could overheat if operated for an extended period with a closed valve in the discharge line.

Cold Weather Preservation

In freezing temperatures, the pump will not freeze as long as it is submerged in liquid. If the pump casing is not submerged, or if the liquid begins to freeze, remove the pump from the sump or wet well and allow it to dry thoroughly. Run the pump for two or three minutes to dry the inner walls.

If the pump freezes, move it into a warm area until completely thawed, or submerge it into the liquid. If the liquid is near freezing, the pump must be submerged for an extended period of time. Start the pump and check for shaft rotation. If still frozen, allow additional thawing time before attempting to restart.

WARNING

```

////////////////////////////////////
//                               //
// Do not attempt to thaw the pump by using a torch or oth- //
// er source of flame. This could damage gaskets or heat //
// the oil within the pump above the critical point and //
// cause the pump to rupture or explode. //
//                               //
////////////////////////////////////

```

TROUBLESHOOTING - SECTION D

WARNING

```

////////////////////////////////////
//
// The electrical power used to operate this pump is high //
// enough to cause injury or death. Obtain the services of //
// a qualified electrician to troubleshoot, test and/or //
// service the electrical components of this pump. //
//
////////////////////////////////////
    
```

Many of the probable remedies listed in the troubleshooting chart below require use of electrical test instruments; for specific procedures, see **Electrical Testing** at the end of the troubleshooting chart.

TROUBLESHOOTING CHART

TROUBLE	POSSIBLE CAUSE	PROBABLE REMEDY
PUMP FAILS TO START, OVER-LOAD UNIT NOT TRIPPED (MANUAL MODE)	Power source incompatible with control box.	Correct power source.
	No voltage at line side of circuit breaker.	Check power source for blown fuse, open breaker, broken lead, or loose connection.
(AUTOMATIC MODE)	Open circuit in motor windings or power cable.	Check continuity.
	Defective motor power cable.	Replace cable.
	Motor defective.	Check for and replace defective unit.
	Liquid level device or control circuits improperly connected to main control box.	Check wiring diagrams; correct or tighten connections.
	Level sensing device(s) improperly positioned.	Position device(s) at proper level.
Level sensing device(s) fouled with mud or foreign material.	Clean sensing device(s).	

TROUBLESHOOTING

TROUBLE	POSSIBLE CAUSE	PROBABLE REMEDY
PUMP FAILS TO START, OVERLOAD UNIT NOT TRIPPED (AUTOMATIC MODE) (cont.)	<p>Float type sensing device(s) tangled or obstructed.</p> <p>Defective liquid level sensing device(s) or control panel.</p>	<p>Check installation for free movement of float.</p> <p>Repair or replace defective unit(s).</p>
OVERLOAD UNIT TRIPS	<p>Low or high voltage, or excessive voltage drop between pump and control box.</p> <p>Defective insulation in motor windings or power cable; defective windings.</p> <p>Impeller jammed due to debris or insufficient clearance.</p> <p>Bearing(s) frozen.</p> <p>Terminal housing incorrectly wired. (Dual voltage or single phase motors only).</p>	<p>Measure voltage at control box. Check that wiring is correct type, size, and length. (See Field Wiring Connection, Section B).</p> <p>Check insulation resistance; check continuity.</p> <p>Disassemble pump and check impeller.</p> <p>Disassemble pump and check bearing(s).</p> <p>Check terminal housing internal connections against motor wiring plate and schematic wiring diagram.</p>
MOTOR RUNS, BUT PUMP FAILS TO DELIVER RATED DISCHARGE	<p>Discharge head too high.</p> <p>Low or incorrect voltage.</p> <p>Discharge throttling valve partially closed; check valve installed improperly.</p> <p>Discharge line clogged or restricted; hose kinked.</p> <p>Liquid being pumped too thick.</p> <p>Strainer screen or impeller clogged.</p>	<p>Reduce discharge head, or install staging adaptor and additional pump.</p> <p>Measure control box voltage, both when pump is running and when shut off.</p> <p>Open discharge valve fully; check piping installation.</p> <p>Check discharge lines; straighten hose.</p> <p>Dilute liquid if possible.</p> <p>Clear clog(s). Stop pump; back flow may flush away debris.</p>

TROUBLE	POSSIBLE CAUSE	PROBABLE REMEDY
MOTOR RUNS, BUT PUMP FAILS TO DELIVER RATED DISCHARGE (cont.)	Insufficient liquid in sump or tank. Worn impeller vanes; excessive impeller clear- ance. Pump running backwards.	Stop pump until liquid level rises. Check impeller and clearance. See PUMP END REASSEMBLY. Check direction of rotation and correct by interchanging any two motor leads at control box. (See Pump Rotation, Section C).
PUMP RUNS WITH EXCES- SIVE NOISE OR VIBRATION	Pumping entrained air. Damaged or unbalanced impeller. Discharge piping not properly supported. Impeller jammed or loose. Motor shaft or bearings defective. Pump cavitation.	Check liquid level in sump; check position of pump and liquid level sensing device(s). Replace impeller. Check piping installation. Check impeller. Disassemble pump and check motor and bearings. Reduce discharge head, or restrict flow on low head appli- cations.

TROUBLESHOOTING

ELECTRICAL TESTING

If you suspect that pump malfunctions are caused by defects in the motor, power cable or control box, perform the following checks to help isolate the defective part.

WARNING

```

////////////////////////////////////
//
// The electrical power used to operate this pump is high //
// enough to cause injury or death. Obtain the services of //
// a qualified electrician to troubleshoot, test and/or //
// service the electrical components of this pump. //
//
////////////////////////////////////

```

CAUTION

Be certain to refer to the wiring diagrams in the INSTALLATION section of this manual before reconnecting any electrical components which have been disconnected.

Test Equipment

A volt/amp/ohmmeter and megohmmeter of adequate range and quality will be required to conduct the following electrical tests. The suggested equipment indicated below is commercially available, or an equivalent substitute may be used.

Equipment	Manufacturer	Use
Amprobe Model 300 or Amprobe, Jr.	Pyramid Instrument Corp. Lynbrook, NY	To check AC Voltage and current (amperage)
Megohmer	Herman H. Sticht Co. 25 Bark Place New York, N.Y.	To measure resistance (ohms) to ground

Voltage Imbalance

Each phase of the incoming three-phase power must be balanced with the other two as accurately as a commercial voltmeter will read. If the phases are balanced, check out the motor as described below. If the phases are out of balance, contact your power company and request that they correct the condition.

TROUBLESHOOTING

- a. Use a voltmeter, Amprobe, or equivalent meter to read the voltage across terminals 1 & 2, 2 & 3, and 1 & 3. in the control box. All three measured voltages must be the same, as accurately as the meter will read. If possible, measure the voltage with the pump off, with the pump running but out of the water, and with the pump running in the water at full load. All the measured voltages at each condition must be the same.
- b. Use an Amprobe or equivalent meter to measure the current draw of each phase while the pump is running at full load and at no load. All three amperage readings must be the same at each condition, as accurately as the meter will read. Nominal amperage values are listed in Table 1, but these apply only when the actual voltage at the site is the nominal voltage listed.
- c. If the voltages are balanced with the pump off, but are unbalanced when the pump is running, a thorough check of the power source, all interconnecting cables, and the pump motor is required to isolate the defect.

Motor And Motor Power Cable Continuity

To check continuity, zero-balance the ohmmeter set at the RX1 scale, and test as follows:

- a. Disconnect the motor power cable leads from the control box and connect the test leads to any two of the three power cable leads (not to the green ground lead or yellow ground/check lead). If there is a high resistance reading on the ohmmeter, there is an open or broken circuit caused by a break in the power cable or motor windings, or by a bad connection between the motor and the power cable. Switch one test lead to the third power lead, and test again.
- b. If an open or broken circuit is indicated, check the power cable for obvious damage, and replace as necessary (see **MAINTENANCE AND REPAIR**). If there is no apparent damage to the motor cable, remove the terminal housing (see **MAINTENANCE AND REPAIR**) and check the continuity of each power cable lead at the terminal posts.
- c. If an open circuit still exists after each lead (terminal) has been tested and tightened, then the **entire** motor power cable must be replaced. Splicing or other means of repair are not recommended.
- d. If no break is found in the power cable, check the motor leads for continuity. If the test reading indicates an open or broken circuit, there is an open circuit in the motor.

NOTE

It is recommended that a pump with a defective motor be returned to Gorman-Rupp, or to one of the Gorman-Rupp authorized Submersible Repair Centers.

Insulation Resistance

To check insulation, zero-balance the ohmmeter set at the RX100K scale, and test as follows:

- a. Disconnect the motor power cable leads from the control box. Connect one test lead to the power cable green ground lead, and touch the other test lead to each of the three power leads in turn.
- b. The reading obtained will indicate resistance values in both the power cable and the motor windings. If the resistance reading is infinity (∞), the insulation is in good condition. If the reading is between infinity (∞) and 1 megohm, the insulation is acceptable but should be rechecked periodically. If the reading is less than 1 megohm, the insulation should be checked more closely; a reading of zero indicates that the power cable or the motor is grounded.
- c. To determine whether the power cable or the motor is grounded, remove the terminal housing (see **MAINTENANCE AND REPAIR**), disconnect the motor leads from the motor terminals, and test the power cable leads and motor leads separately.

MAINTENANCE AND REPAIR - SECTION E

MAINTENANCE AND REPAIR OF THE WEARING PARTS OF THE PUMP WILL MAINTAIN PEAK OPERATING PERFORMANCE.

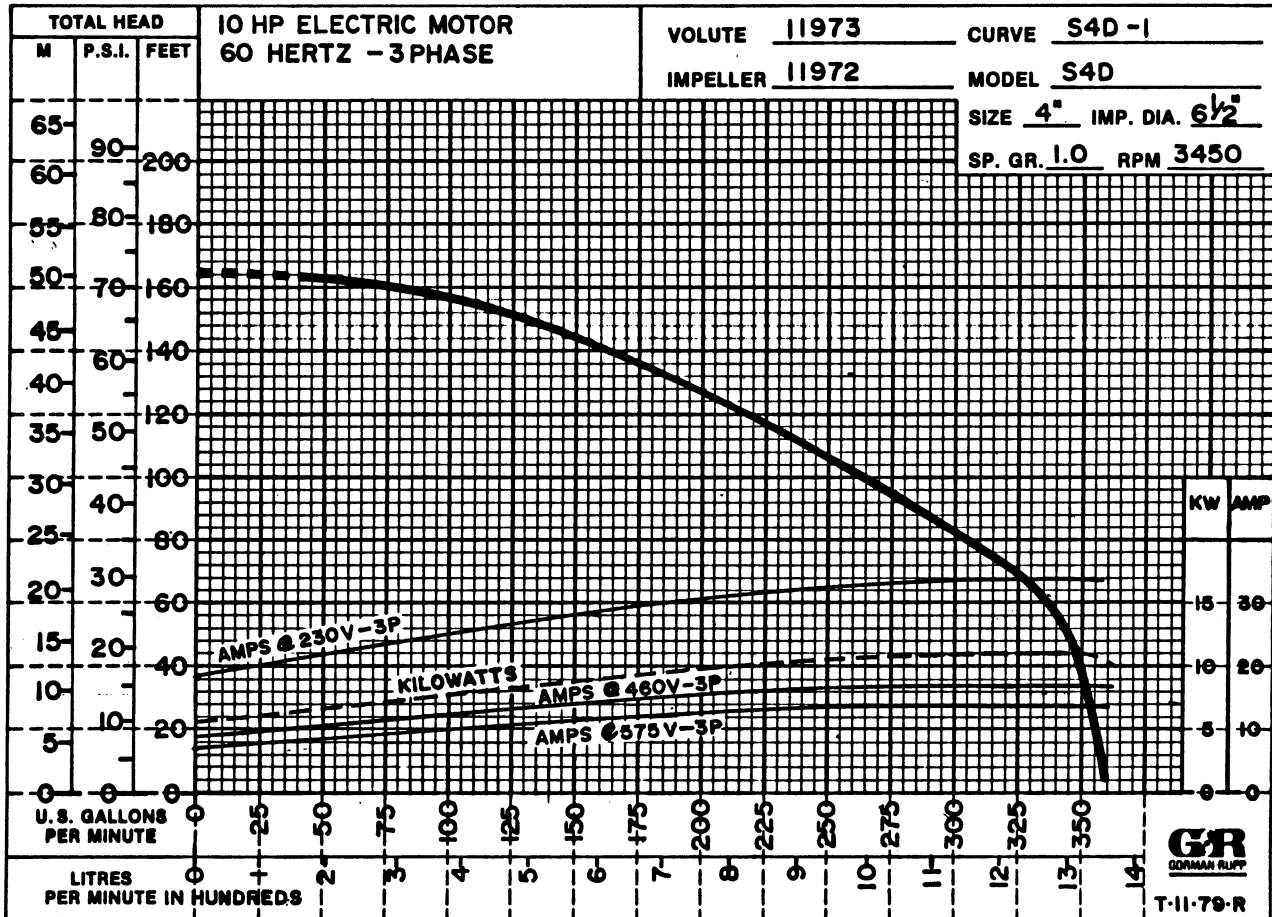

*STANDARD PERFORMANCE FOR PUMP MODEL S4D1-460V 3P

*Based on 70°F clear water at sea level. Since pump installations are seldom identical, your performance may be different due to such factors as viscosity, specific gravity, elevation, temperature, and impeller trim.

If your pump serial number is followed by an "N", your pump is NOT a standard production model. Contact the Gorman-Rupp Company to verify performance or part numbers.

SECTIONAL DRAWING

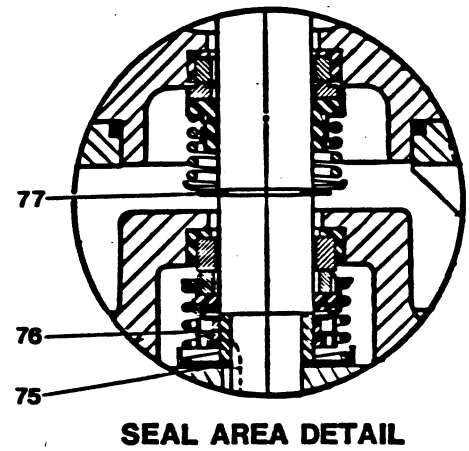
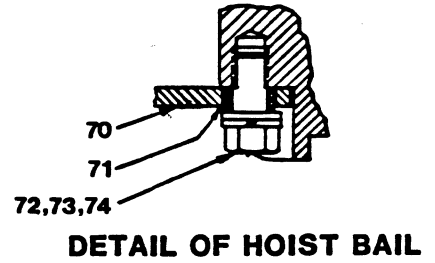
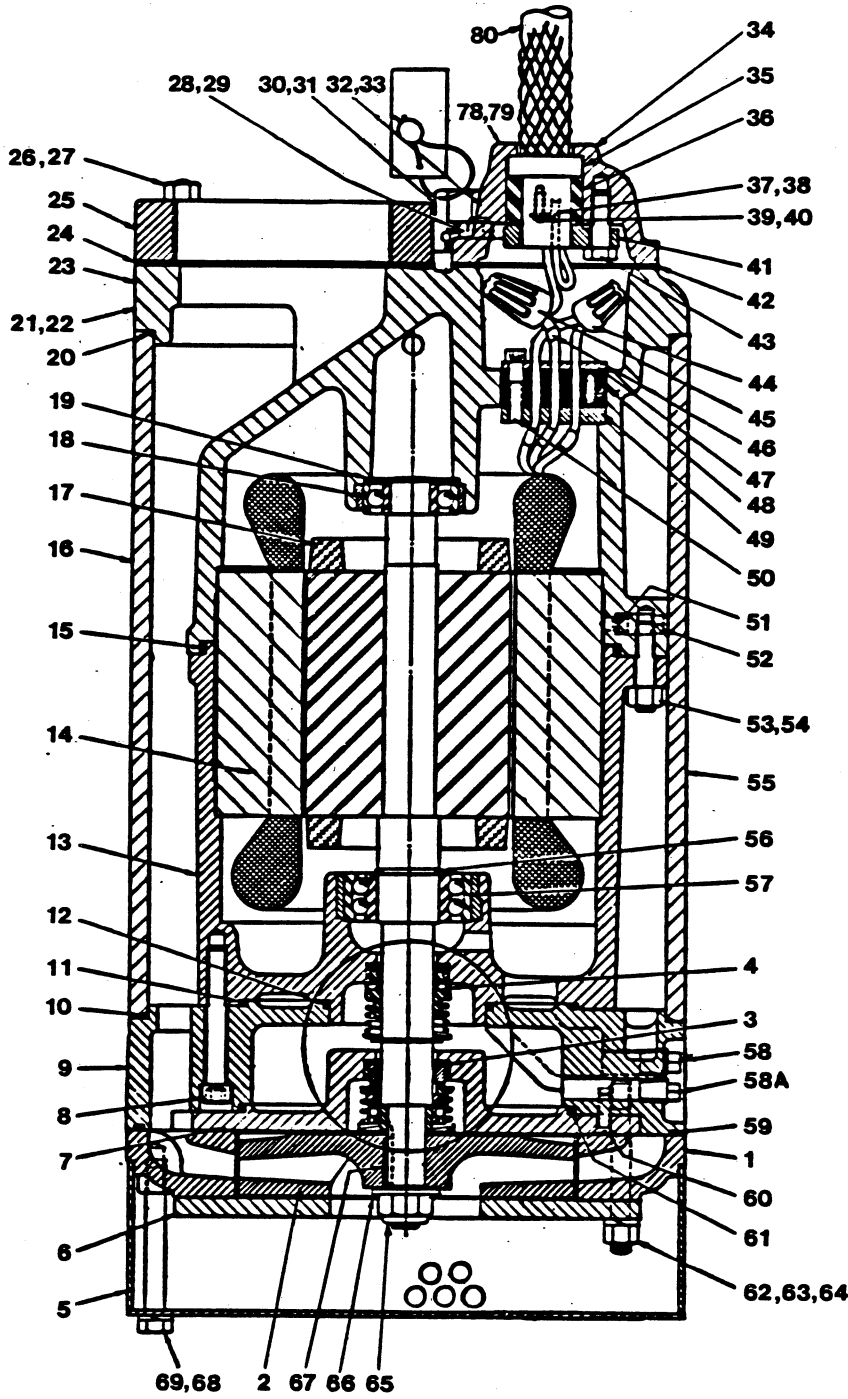

Figure 1. Pump Model S4D1-460V 3P

PARTS LIST
Pump Model S4D1-460V 3P
 (From S/N 741793 up)

If your pump serial number is followed by an "N", your pump is NOT a standard production model. Contact the Gorman-Rupp Company to verify part numbers.

ITEM NO.	PART NAME	PART NUMBER	MATL CODE	QTY	ITEM NO.	PART NAME	PART NUMBER	MATL CODE	QTY
1	DIFFUSER	11973	11010	1	57	*LOWER BALL BRG	S01834	-----	1
2	*IMPELLER	11972	11010	1	58	MOTOR CAVITY	P00004	17000	1
3	*LOWER SEAL ASSY	S01841	-----	1		DRAIN PLUG			
4	*UPPER SEAL ASSY	S01832	-----	1	58A	SEAL CAVITY	P00004	17000	1
5	STRAINER	11969	24001	1		DRAIN/FILL PLUG			
6	*WEAR PLATE	11948-A	15010	1	59	*INTERM O-RING	S01830	-----	1
7	SEAL PLATE	13882	11010	1	60	FLT HD MACH SCREW	Y#10-03	17000	3
8	SOCKET HD CAPSCREW	DM00609	17000	3	61	*SEAL PLATE GSKT	13928	20000	1
9	INTERMEDIATE	13883	13040	1	62	HEX NUT	D00006	17000	3
10	*INTERMEDIATE O-RING	S01830	-----	1	63	LOCKWASHER	J00006	17000	3
11	*INTERMEDIATE GSKT	13928	20000	1	64	STUD	C00612	17000	3
12	*INTERMEDIATE GSKT	13929	20000	1	65	DEFORMED LOCKNUT	22565-050	-----	1
13	MOTOR HSG - LOWER	11943-B	13040	1	66	IMP FLAT WASHER	KB00010	17000	1
14	STATOR ASSY	47113-803	-----	1	67	*IMPELLER KEY	N00303 1/2	17000	1
15	*MOTOR HSG GSKT	11941-G	20000	1	68	LOCKWASHER	J00006	15991	3
16	PUMP CASING	11982	13175	1	69	HEX HD CAPSCREW	B00612	15991	3
17	*ROTOR ASSY	47112-807	-----	1	70	HOISTING BAIL	11959	24001	1
18	*UPPER BALL BEARING	S01044	-----	1	71	BUSHING	9562	15991	2
19	SPRING WASHER	S01554	-----	1	72	LOCKWASHER	J00008	15991	2
20	*PUMP CASING O-RING	S01830	-----	1	73	FLAT WASHER	KE00008	15991	2
21	NAME PLATE	2613-DD	17020	1	74	HEX HD CAPSCREW	B00804	15991	2
22	DRIVE SCREW	BM#04-03	17000	4	75	*IMP ADJ SHIMS	2-Y	17090	1
23	MOTOR HSG - UPPER	11941-B	13040	1	76	*SEAL SLEEVE	13878	17020	1
24	*DISCH FLANGE GSKT	11957-G	20000	1	77	SEAL RET RING	S00362	-----	1
25	*DISCH FLANGE	11957	13040	1	78	DRIVE SCREW	BM#04-03	17000	4
26	STUD	C00609	15991	4	79	MOTOR PLATE	10436	17000	1
27	HEX NUT	D00006	15991	4	80	POWER CABLE	10325-C	-----	1
28	STUD	C00606	15991	4		NOT SHOWN:			
29	DEFORMED LOCKNUT	DD00006	15991	4		460V CONTROL BOX	27514-322	-----	1
30	*RELIEF VALVE ASSY	46431-608	-----	1		SUBMERSIBLE MOTOR	9568	-----	1
31	REDUCER BUSHING	AP00604	15991	1		OIL - 1 QUART			
32	INFORMATION PLATE	38816-047	17990	1		MOTOR CABLE TIE	27111-212	-----	1
33	DRIVE SCREW	BM#04-03	17000	4		OPTIONAL:			
34	TERMINAL HOUSING	11955	13040	1		230V CONTROL BOX	27514-321	-----	1
35	CABLE GRIP	11227-C	-----	1		REPAIR GSKT SET	11000-R	-----	1
36	CABLE BUSHING	10758-B	19100	1		SST SEAL PLATE	13882	17070	1
37	*TERMINAL	S01836	-----	1		SST WEAR PLATE	11948-A	17070	1
38	*TERMINAL	27214-243	-----	1		SST DIFFUSER	11973	17070	1
39	RD HD MACHINE SCREW	X#10-02	15991	2		SST IMPELLER	11972	17070	1
40	T-TYPE LOCKWASHER	AK#10	15991	2		STAGING ADAPTOR	13369-A	24000	1
41	TERMINAL CAP	11956	13040	1		ASSEMBLY			
42	*TERMINAL HSG GSKT	11955-G	20000	1		OVERLOAD HEATER FOR DUAL VOLTAGE:			
43	HEX HD CAPSCREW	B00604	15991	2		230V - 60 HZ	11960-A	-----	3
44	CONNECTOR	S01718	-----	3		460V - 60 HZ	11960-B	-----	3
45	CONNECTOR	S02293	-----	1		220V - 50 HZ	11960-D	-----	3
46	WIRE MARKER SET	S02274	-----	1		380V - 50 HZ	11960-E	-----	3
47	UPPER TERM PLATE	13880	23010	1		LIQUID LEVEL DEVICES:			
48	MOTOR LEAD BUSHING	13884	19140	1		DIAPHRAGM TYPE	GRP48-03 or GRP48-06	-----	1
49	LOWER TERM PLATE	13881	23010	1		FLOAT TYPE	27471-155	-----	1
50	SOCKET HD CAPSCREW	13879	15990	4		LOW VOLT CONTROL	S01657	-----	1
51	ALLEN HD SETSCREW	GA00501 1/4	15990	2		(24 VOLT)			
52	PIPE PLUG	38649-022	17030	2					
53	STUD	C00606	17000	8					
54	DEFORMED LOCKNUT	DD00006	17000	8					
55	INSTRUCTION TAG	6588-AJ	00000	1					
56	BEARING SNAP RING	S01831	-----	1					

*INDICATES PARTS RECOMMENDED FOR STOCK

Above Serial Numbers Do Not Apply To Pumps Made In Canada.

CANADIAN SERIAL NO AND UP

PUMP AND MOTOR DISASSEMBLY AND REASSEMBLY

The following maintenance and repair instructions are keyed to the sectional view (see Figure 1) and the accompanying parts list.

WARNING

```

////////////////////////////////////
//
// The electrical power to operate this pump is high enough //
// to cause injury or death. Make certain that the control //
// handle on the control box is in the OFF position and //
// locked, or that the power supply to the control box has //
// been otherwise cut off and locked out, before attempting //
// to open or service the pump assembly. Tag electrical //
// circuits to prevent accidental start-up. //
// //
////////////////////////////////////

```

Before attempting to service the pump or control, cut off the power supply to the control box and close any valves in the discharge line.

WARNING

```

////////////////////////////////////
//
// Do not attempt to lift the pump by the motor power cable //
// or the piping. Attach proper lifting equipment to the //
// hoisting bail fitted to the pump. If chains or cable //
// are wrapped around the pump to lift it, make certain //
// that they are positioned so as not to damage pump, and //
// so that the load will be balanced. //
// //
////////////////////////////////////

```

Use the hoisting bail to lift the pump from the wet well or sump and move it to a location where the discharge line can be removed. If discharge hose is used with this pump, it is not necessary to disconnect the hose before removing the pump from the sump or wet well. If rigid discharge piping is used, disconnect the piping or the discharge flange (25) before attempting to remove the pump.

To remove the discharge flange, remove the nuts (27) securing the flange to the upper motor housing (23).

Select a suitable location, preferably indoors, to perform the degree of maintenance required. If the motor housing is to be opened, the work must be done in a clean well-equipped shop. All maintenance functions must be performed by qualified personnel.

Check the chart in **TROUBLESHOOTING** to determine the nature of the pump problem. If the problem is mechanical in nature, such as worn pump parts, seal replacement, lubrication, etc., refer to **PUMP END DISASSEMBLY**. If the problem is electrical, complete disassembly of the pump may not be required. Refer to **Electrical Testing** and have a qualified electrician check out control box, cable and terminal housing assembly. If problem is determined to be in the motor, proceed with **PUMP END DISASSEMBLY** followed by **MOTOR DISASSEMBLY**.

All gaskets and most O-rings **must** be replaced if disturbed. A repair gasket kit is listed on the parts list as an option.

PUMP END DISASSEMBLY

Strainer Disassembly

To remove the strainer assembly (5), raise the pump slightly or lay it on its side and remove hardware (68 and 69) securing the strainer to the diffuser (1). If the impeller is clogged, the debris can usually be removed without further disassembly.

Draining Oil From Seal And Motor

After removing the strainer, the wear plate (6), diffuser (1) and impeller (2) may be serviced without draining the oil cavities. However, the oil should be drained before attempting to replace the shaft seals (3 and 4) or repair the motor.

CAUTION

Let the pump cool before removing the seal or motor cavity drain plug. Pressure built up within a hot pump could cause the oil to spray out when the plug is removed. Remove the plug slowly and permit pressure to vent to atmosphere.

Lay the pump on its side with the drain plug facing up, clean any dirt from around the seal cavity drain/fill plug (58A) and motor cavity drain plug (58). Remove seal cavity plug (58A) and install a short 1/4-inch NPT nipple in the hole. Tip the pump up and drain the seal oil into a **clean** container. Inspect it for water, dirt or cloudy condition which could indicate lower seal failure or poor gasket seal.

If motor problems are suspected, remove motor cavity plug (58) and use a short nipple to drain the oil into a **clean** container at this time. Inspect the oil for dark color which could indicate motor overheating, dirt or water contamination. The presence of dirt or water could indicate a breakdown in the waterproof integrity of the motor cavity, probably due to poor gaskets or seals.

Positioning Pump For Disassembly

It is recommended that the pump be positioned upside-down during disassembly. To hold the pump in an inverted position, secure the discharge flange studs (26) to a bench or work stand, or rest the pump securely on blocks. Be careful not to damage the terminal housing (34), power cable (80), or pressure relief valve (30) while the pump is in this position. Use adequate equipment and personnel to safely handle the pump until it is secured.

If inverting the pump is not practical, lay the pump on its side and secure it.

Impeller Disassembly

For access to the impeller (2), remove the hardware (62 and 63) securing the wear plate (6) and diffuser (1) to the intermediate (9). Pull the wear plate and diffuser off the studs. Remove and discard O-ring (59).

Wedge a piece of wood between the vanes of impeller (2) and intermediate stud to prevent shaft rotation. Unscrew locknut (65) and remove flat washer (66). Pry the impeller off using two screwdrivers as shown in Figure 2. Use caution when removing the impeller; tension of the seal spring will be released. Retain the impeller key (67).

Remove the impeller adjusting shims (75); for ease of reassembly, tie and tag the shims.

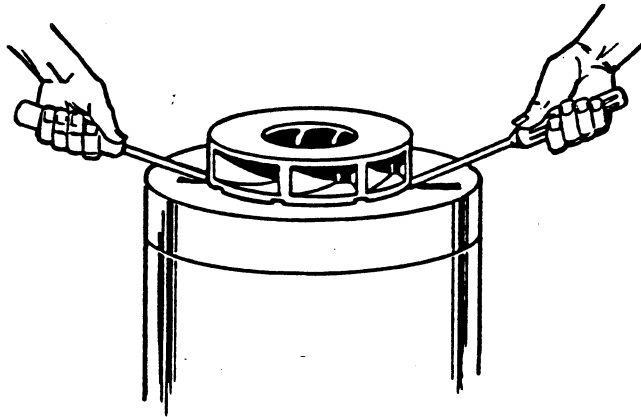

Figure 2. Removing Impeller

Outer Seal Disassembly

(Figure 1 and 3)

Carefully remove the loose parts of the outer seal assembly (3). Lubricate the shaft sleeve (76) adjacent to the seal, and work oil under the rubber bellows. Use a stiff wire with a hooked end to pull the shaft sleeve and rotating portion of the seal from the shaft. Separate the sleeve from the rubber bellows.

To remove the stationary portion of the seal, remove the flat head machine screws (60), securing the seal plate (7) to the intermediate (9). Remove and discard the seal gasket (61). Place the seal plate on a flat surface with the impeller side down. Use a drift pin or screw driver to press on alternate sides of the stationary seat until removed.

The rotating and stationary seal elements are precision finished and subject to wear. The complete seal should be replaced with each overhaul to ensure trouble-free operation. However, if the old seal must be reused, wrap the seal faces individually in tissue paper to prevent damage to the sealing surfaces.

If no further disassembly is required, proceed to appropriate areas in **Pump End Reassembly**.

Inner Seal Disassembly

(Figure 1 and 3)

Unless cracked or otherwise worn, it is not necessary to remove the intermediate (9) for access to the inner seal assembly (4). If desired to remove the intermediate, remove the socket head capscrews (8) securing it to the lower motor housing (13).

Remove the seal retaining ring (77) with snap ring pliers. Use caution when removing the snap ring; tension on the seal spring will be released. Remove the seal spring retainer and spring. Lubricate the rotor shaft adjacent to the seal, and work oil under the bellows. Use a stiff wire with a hooked end to pull the rotating seal portion off the shaft.

Slide the hooked ends of two wires along the shaft and under the stationary seal seat. Hook the back side of the seat and pull it from the intermediate.

NOTE

Do not disassemble the motor unless it is necessary and a clean, well-equipped shop is available. If the motor housing components are to be serviced, see **MOTOR DISASSEMBLY** in this section. Do not reassemble the pump end components at this time.

If no further disassembly is required, proceed to appropriate areas in **Pump End Reassembly**.

PUMP END REASSEMBLY

NOTE

Reuse of old O-rings, gaskets, or shaft seal parts may result in premature leakage or reduced pump performance. It is strongly recommended that an overhaul gasket kit and new shaft seal assemblies be used during reassembly (see the parts list for part numbers).

Cleaning Old Parts

With the pump inverted, stuff a clean tissue into the stationary seat bore of the intermediate (or wrap a small rag around the shaft) to prevent foreign material from entering the motor cavity.

Carefully inspect O-rings or gaskets before removal and cleaning to determine if a proper seal and compression existed prior to disassembly. If sealing was faulty or questionable, the cause must be determined and corrected before reassembly. Replace any parts required.

Thoroughly clean all reuseable parts with a soft cloth soaked in cleaning solvent. Remove all O-rings and gaskets and clean the sealing surfaces of dirt or gasket material. Be careful not to scratch gasket surfaces.

WARNING

```

////////////////////////////////////
//
// Most cleaning solvents are toxic and flammable. Use //
// them only in a well-ventilated area free from excessive //
// heat, sparks, and flame. Read and follow all prec- //
// autions printed on solvent containers. //
//
////////////////////////////////////

```

Neither of the shaft seal assemblies should be reused because wear patterns on the finished faces cannot be realigned during reassembly. This could result in premature failure. If necessary to reuse an old seal in an emergency, **carefully** wash all metallic parts in fresh cleaning solvent and allow to dry thoroughly.

Handle the seal parts with extreme care to prevent damage. Be careful not to contaminate precision finished faces; even fingerprints on the faces can shorten seal life. If necessary, clean the faces with a non-oil based solvent and a clean lint free tissue. Wipe **lightly** in a concentric pattern to avoid scratching the faces.

Inspect the seal components for wear, scoring, grooves, and other damage that might cause leakage. If any components are worn, replace the complete seal; **never mix old and new seal parts.**

Install the shaft seals as illustrated in Figure 3.

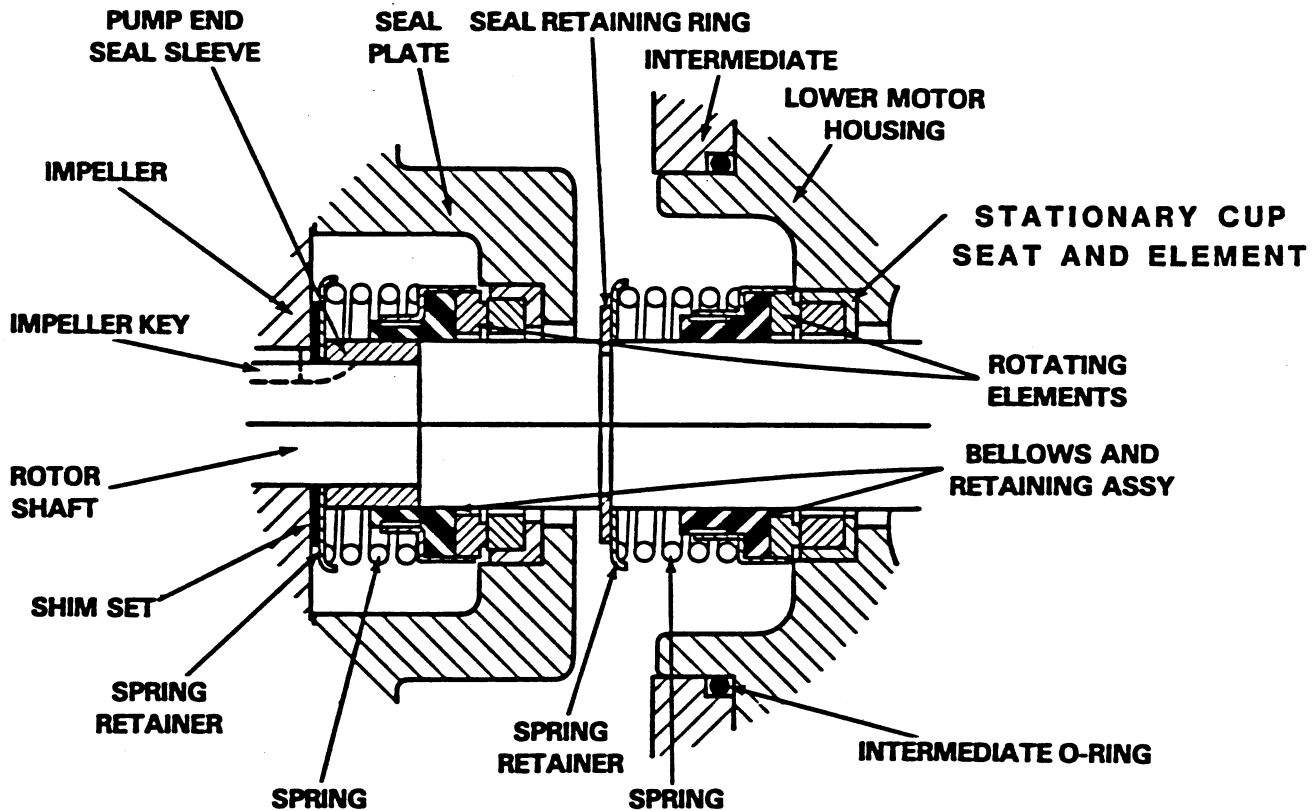

Figure 3. Seal Assemblies S01841 and S01832

Inner Seal Reassembly

If the intermediate (9) has been removed, replaced the intermediate O-ring (10) and both intermediate gaskets (11 and 12), and position the intermediate on the lower motor housing (13). Coat the threads of the socket head capscrews (8) with "Never-Seez" or equivalent compound, and install the capscrews through the intermediate and into the lower motor housing; torque to 22 ft. lbs. (264 inch lbs.).

If a new seal is to be installed, do not unwrap it until time of installation. Cleanliness of all seal components is a must, especially the seal faces.

Clean the rotor shaft and seal cavity area of the intermediate (9). Be sure the area is dry and free of lint and dirt.

Carefully remove the material stuffed into the seat bore (or unwrap the shaft). Be sure no debris stopped by the material falls into the motor cavity.

Carefully clean the seal bore in the intermediate (9). Check for burrs or nicks that might cut seal components or prevent a good seal. Apply a light coating of oil to the bore.

MAINTENANCE AND REPAIR

NOTE

When pressing seal components on impeller shaft, use hand pressure only. A push tube cut from a length of plastic pipe will aid in installing seal components. The I.D. of the push tube should be approximately the same as the I.D. of the seal spring.

Unpack the stationary seat and element. Subassemble the two parts and place a clean tissue over the seal face, and press the assembly into the seal bore until it bottoms. Remove the tissue and inspect the seal face to ensure that it is clean and dry. If cleaning is necessary, use clean tissue to wipe lightly in a concentric pattern.

Unpack the rotating portion of the seal. Be certain the seal face of the rotating element is free of grit or surface damage. Assemble the drive grooves of the rotating element into the drive lugs of the bellows retainer.

Apply a light coating of oil on the rotor shaft and I.D. of the bellows. Place the rotating seal portion on shaft with seal face down. If the rotating element does not stay in the bellows retainer when turned upside down, place a **small** amount of grease at equal spaces on the back of the element and position it into the bellows retainer. The grease should hold the element in position until the seal is installed. Apply firm, steady pressure, with clean hands, on the seal retainer until it slides down the shaft and makes contact with the stationary element.

Slide the seal spring over the bellows retainer, and install the spring retainer. Install the seal retaining ring (77). See Figure 3 for proper order of seal assembly.

Outer Seal Reassembly

Thoroughly clean the gasket surfaces and seal bore of the seal plate (7). The seal bore must be free of burrs and nicks which could damage the seal.

Replace the seal plate gasket (61). Position the seal plate on the intermediate (9) and rotor shaft, and secure the seal plate to the intermediate with the flat head machine screws (60).

NOTE

When pressing seal components on impeller shaft, use hand pressure only. A push tube cut from a length of plastic pipe will aid in installing seal components. The I.D. of the push tube should be approximately the same as the I.D. of the seal spring.

Unpack the stationary seat and element and subassemble the two parts. Place clean tissue over the sealing face, and press the assembly into the seal bore until it bottoms. Remove the tissue and inspect the seal face to ensure that it is clean and dry. If cleaning is necessary, use clean tissue to wipe lightly in a concentric pattern.

Install the seal sleeve (76) so that the chamfered side faces the shaft shoulder. Lubricate the O.D. with a light coating of oil.

Unpack the rotating portion of the seal. Be certain the seal face of the rotating element is free of grit or surface damage. Assemble the drive grooves of the rotating element into the drive lugs of the bellows retainer.

Apply a light coating of oil on the rotor shaft and I.D. of the bellows. Place the rotating seal portion on shaft with seal face down. If the rotating element does not stay in the bellows retainer when turned upside down, place a **small** amount of grease at equal spaces on the back of the element and position it into the bellows retainer. The grease should hold element in position until the seal is installed. Apply firm, steady pressure, with clean hands, on the seal retainer until it slides down the shaft and makes contact with the stationary element.

Slide the seal spring over the bellows retainer, and install the spring retainer. See Figure 3 for proper order of seal assembly.

Impeller Reassembly

Reinstall the impeller adjusting shims (75).

Inspect the impeller (2), and replace it if cracked or worn.

Install the impeller key (67) and the impeller. After the impeller has been installed, coat the threads of the rotor shaft with "Never-Seez" or equivalent compound. Install the impeller flat washer (66) and deformed locknut (65). Place a block of wood between the vanes of the impeller to prevent shaft rotation, and torque the deformed locknut to 120 ft. lbs. (1440 inch lbs.).

Turn the impeller to check for free rotation.

Diffuser, Wear Plate And Screen Reassembly

Thoroughly clean the diffuser (1) and its O-ring surfaces. Replace the O-ring (59), and install it in the groove in the intermediate (9).

Inspect the wear plate (6). If one side is eroded, flip it over and install the smooth side next to the impeller. Replace it if both sides are badly scored or worn.

Carefully position the diffuser and wear plate over the studs (64) in the intermediate (9), and secure them with nuts and lockwashers (62 and 63).

Check impeller rotation, and adjust clearance by centering the impeller in the diffuser (1). To center, add or remove impeller adjusting shims (75) as required.

Carefully position the strainer (5) on the diffuser (1), and secure with hardware (68 and 69). Make certain that the strainer sits properly against the shoulder of the diffuser.

MAINTENANCE AND REPAIR

MOTOR DISASSEMBLY

Disassembly of the motor is rarely required except to replace the motor rotor, stator, bearings, or intermediate. Do not disassemble the motor unless it is necessary and a clean, well-equipped shop is available.

NOTE

It is recommended that a pump with a defective motor be returned to Gorman-Rupp, or to one of the Gorman-Rupp authorized Submersible Repair Centers.

WARNING

```

////////////////////////////////////
//
// The electrical power to operate this pump is high enough //
// to cause injury or death. Make certain that the control //
// handle on the control box is in the OFF position and //
// locked, or that the power supply to the control box has //
// been otherwise cut off and locked out, before attempting //
// to open or service the pump assembly. Tag electrical //
// circuits to prevent accidental start-up. //
// //
////////////////////////////////////

```

Carefully inspect any O-rings or gaskets before removal and cleaning to determine if a proper seal and compression existed prior to disassembly. If sealing was faulty or questionable, the cause must be determined and corrected before reassembly. Replace any parts as required.

Terminal Housing And Power Cable Disassembly

If the pump is maintained in an upright position, the terminal housing (34) may be serviced without draining the oil from the motor cavity. However, the oil must be drained before attempting to disassemble the motor housings (13 and 23) and components. To drain the oil, see **Draining Oil in PUMP END DISASSEMBLY.**

Total disassembly of the terminal housing and power cable is not always required. Disassemble and replace only the parts which have been proven defective by inspection or testing. See **Electrical Testing in TROUBLESHOOTING.**

To remove the terminal housing (34), remove the deformed locknuts (29) securing the terminal housing to the upper motor housing (23). Raise the terminal housing for access to the connectors (44 and 45) securing the power cable leads to the motor leads. The connectors are wrapped with underwater tape; cut and unwrap the tape, remove the connectors, and separate the power cable leads from the motor leads to free the terminal housing and assembled parts.

If the power cable is to be replaced, remove the round head machine screws (39) and T-type lockwashers (40) securing the power cable ground wires to the terminal housing, and slide the terminal housing back along the cable. Remove the capscrews (43) securing the terminal cap (41) to the terminal housing, and remove the bushing (36) and the cable grip (35). Pull the power cable from the terminal housing.

If no further disassembly is required, see **Terminal Housing And Power Cable Reassembly**.

Pump Casing And Motor Housing Disassembly

Drain the oil from the motor housing cavity before removing the motor components.

NOTE

If the oil drained from the motor housing cavity is cloudy or contains foreign liquid, it may be an indication that the shaft seal is leaking at the motor end.

See **Pump End Disassembly** and remove all pump end components.

With the pump end disassembled and the intermediate (9) removed, slide the pump casing (16) off the upper and lower motor housings.

Remove the deformed locknuts (54), and separate the lower motor housing (13) from the upper motor housing (23). If necessary, pry the housings apart using two screwdrivers as shown in Figure 4. Pry gently to loosen the gasket seal.

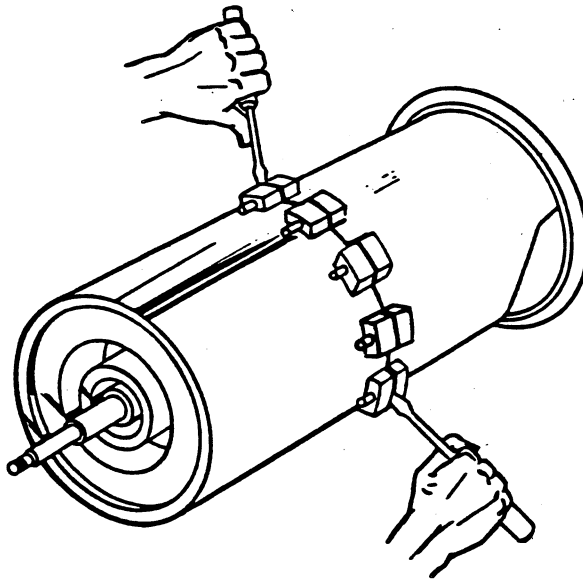

Figure 4. Separating Upper And Lower Motor Housings

Rotor And Stator Disassembly

Carefully pull the rotor (17) and the assembled ball bearings (18 and 57) from the stator. Hold the rotor carefully to prevent it from falling on the stator

windings. Reach into the upper housing and remove the wavy spring washer (19) from the bearing bore.

Remove the lower and upper ball bearings if rotation is rough, or if the balls are discolored. Use a bearing puller if necessary.

It is recommended that the stator (14) be left in place unless it is defective.

If the stator must be removed, remove the socket head capscrews (50) securing the upper terminal plate (47), motor lead bushing (48), and lower terminal plate (49), and remove these parts by pulling them over the motor leads.

Remove the pipe plug (52) located in the upper motor housing, and loosen the allen head setscrew (51) located underneath the pipe plug.

Position an expandable tool, such as a split disc, approximately 2 inches down inside the stator, and expand the tool tightly and squarely on the I.D. Attach a lifting device to center lifting eye of the tool and raise the assembly one inch off floor. Take care not to damage the stator end turns. Use a soft-faced mallet to rap alternate edges of the upper motor housing (23), and "walk" the stator out. Continue this process until the stator clears the motor housing.

NOTE

It may be necessary to heat the motor housing to permit stator removal.

After the stator has been removed, wrap it in clean dry rags or other suitable material. The stator **must** be kept clean and dry. When handling the stator, do not set it on the end windings; lay it on its side.

CAUTION

Do not attempt to rewind the stator. Winding tolerances and materials are closely controlled by the manufacturer, and any deviation can cause damage or operating problems. Replace the stator, or return it to one of The Gorman-Rupp Authorized Submersible Repair Centers or The Gorman-Rupp factory, if defective.

Relief Valve

It is recommended that the relief valve assembly (30) be replaced at each overhaul, or at any time the pump motor overheats and activates the valve. Never replace this valve with a substitute which has not been specified or provided by the Gorman-Rupp Company.

NOTE

It is not necessary to remove the reducing pipe bushing (31) to remove the relief valve assembly. If the pipe bushing is removed, apply "Loctite #35 or #70" to the male threads of the bushing only.

When installing the relief valve, use "Loctite Pipe Sealant With Teflon" or equivalent compound on the threads.

Hoisting Bail

If the hoisting bail (70) requires replacement, remove the hardware (72, 73, and 74) securing the bail to the upper motor housing (23). Make certain that the bushing (71) is in place when installing the hoisting bail.

MOTOR REASSEMBLY

WARNING

```

////////////////////////////////////
//                               //
// Refer to the wiring diagrams in INSTALLATION when recon- //
// necting motor and power leads and power cable leads.     //
//                               //
////////////////////////////////////

```

NOTE

Reuse of old O-rings, gaskets, or shaft seal parts may result in premature leakage or reduced pump performance. It is strongly recommended that an overhaul gasket kit and new shaft seal assemblies be used during reassembly (see the parts list for parts numbers).

Stator Reassembly

Clean all gasket and O-ring surfaces completely, removing any old gasket and cement material. Inspect the sealing surfaces for burrs, nicks, and pits which could cause a poor seal. Replace parts as required.

Thoroughly clean the inside of the upper motor housing (23) with fresh solvent. The interior must be dry and free of dirt or lint.

WARNING

```

////////////////////////////////////
//
// Most cleaning solvents are toxic and flammable. Use //
// them only in a well-ventilated area free from excessive //
// heat, sparks, and flame. Read and follow all prec- //
// autions printed on solvent containers. //
// //
////////////////////////////////////

```

Do not unwrap the stator until the motor housing has been prepared for stator installation. The stator must be kept clean and dry. When handling stator, do not set it on its end windings. Lay it on its side.

Test the stator as indicated in **Electrical Testing** in **TROUBLESHOOTING** to ensure that no damage has occurred during handling.

Position an expandable tool, such as a split disc, approximately 2 inches down inside the stator, and expand the tool tightly and squarely on the I.D. Attach a lifting device to center lifting eye of the tool and carefully lift the assembly. Take care not to damage the stator end turns. Slip a sleeve over the stator lead wires to prevent damage to them.

With the upper motor housing (23) in an inverted position, carefully lower the stator into the motor housing, guiding the leads through the opening left after the terminal plates (47 and 49) and bushing (48) were removed; be careful not to damage the stator leads insulation. If the stator "cocks" in the motor housing, remove it and try again. If heating the motor housing is necessary, the stator must be clear of the housing to avoid heat damage to the windings. Apply heat evenly to the inside of the motor housing; excessive heat is not required.

After the stator is fully and squarely seated on the upper motor housing shoulder, remove the split disc or other tool, and cover the motor housing with a clean, lint-free cloth while the rotor is being assembled.

Rotor Assembly

Inspect the seal and bearing areas of the shaft, and replace the shaft and rotor (a single assembly) if any area of the shaft is damaged.

Clean the bore of the upper motor housing (23), and install the spring washer (19) in the bore.

Install the lower bearing snap ring (56) on the rotor shaft, and press the lower ball bearing (57) on the shaft so that the loading grooves are facing toward the rotor and the bearing is fully seated against the snap ring.

CAUTION

<p>When installing the bearings onto the shaft, NEVER press or hit against the outer race, balls, or ball cage. Press ONLY on the inner race.</p>

MAINTENANCE AND REPAIR

Press the upper ball bearing (18) on the rotor shaft until fully seated against the shaft shoulder.

Slip the assembled rotor, shaft, and bearing through the stator, and seat the upper ball bearing squarely in the upper motor housing bore.

Clean both bores and all gasket and O-rings surfaces of the lower motor housing (13), completely removing any old gasket and cement material. Inspect the sealing surfaces for burrs, nicks and pits which could cause poor seal. Repair or replace as required.

WARNING

```

////////////////////////////////////
//
// Most cleaning solvents are toxic and flammable. Use //
// them only in a well-ventilated area free from excessive //
// heat, sparks, and flame. Read and follow all prec- //
// autions printed on solvent containers. //
// //
////////////////////////////////////

```

Replace the motor housing gasket (15). Drop the lower motor housing (13) down over the rotor shaft and assembled bearings and onto the upper motor housing (23). Be careful not to cut the motor housing gasket.

Coat the upper motor housing studs (53) with "Never-Seez" or equivalent compound, and install the deformed locknuts (54) to secure the upper and lower motor housings; torque the locknuts to 20 ft. lbs. (240 inch lbs.).

Install the allen head setscrews (51) securing the stator in place, and torque the setscrew to 7.5 ft. lbs. (90 inch lbs.). Coat the threads of the pipe plug (52) with "Loctite Pipe Sealant With Teflon #92" or equivalent sealant, and install the plug over the allen head setscrew.

Clean the sealing surfaces at each end of the pump casing (16), replace the O-ring (20), and slide the pump casing into position around the motor housings.

Lubricate the motor leads, bores of the lower terminal plate (49), motor lead bushing (48), and upper terminal plate (47), and the O.D. of the bushing and I.D. of the bushing bore.

Feed the motor leads through the lower terminal plate and motor lead bushing. After the leads are 1-1/2 to 2 inches above the bushing, feed them through the upper terminal plate. Start two of the four socket head capscrews (50) through the upper plate, bushing, and lower plate, but do not tighten the capscrews. Push the assembly into the motor bushing bore until the lower plate bottoms against the shoulder in the motor housing. Make certain that the motor leads are sufficiently long to permit connections to the pump power cable, and install the two remaining socket head capscrews; torque all the capscrews alternately and evenly to 4 ft. lbs. (48 inch lbs.).

See PUMP END REASSEMBLY, and reassemble the pump end components.

MAINTENANCE AND REPAIR

Terminal Housing And Power Cable Reassembly

WARNING

```

////////////////////////////////////
//
// The electrical power used to operate this pump is high //
// enough to cause injury or death. Make certain that the //
// control handle on the control box is in the OFF position //
// and locked, or that the power supply to the control box //
// has been otherwise cut off and locked out. Tag elec- //
// trical circuits to prevent accidental start-up. Obtain //
// the services of a qualified electrician and refer to the //
// wiring diagrams in INSTALLATION to make all electrical //
// connections. //
// //
////////////////////////////////////

```

Clean the exterior of the pump power cable with warm water and mild detergent, and check for obvious physical damage. Check the cable for continuity and insulation resistance (see **Electrical Testing** in TROUBLESHOOTING).

CAUTION

Do not attempt repairs except at either end of the power cable. Splicing is not recommended.

If the ends of the power cable leads are frayed or broken, cut them off beyond the damaged area and strip back insulation about 1/2 inch.

Clean the bore and the gasket surfaces of the terminal housing (34), completely removing any old gasket or cement material. Inspect the sealing surfaces for burrs, nicks, and pits which could cause a poor seal. Repair or replace as required.

Lubricate the outside of the power cable and the bore of the cable grip (35), bushing (36), and terminal cap (41) for ease of assembly. Slip the terminal housing (34) over the power cable, and insert the cable through the cable grip, bushing, terminal cap until the power cable leads are long enough to permit wire connections. Secure the terminal cap to the terminal housing with capscrews (43).

Connect the two green ground leads to one terminal housing terminal (37), and the single yellow lead to the other terminal (38), and secure with T-type lockwashers (40) and round head machine screws (39). Make certain that the leads make good contact with the terminal housing.

Match the colors of the motor leads and the power cable leads and connect them. Install the respective connectors (44 and 45), and use underwater tape (Gorman-Rupp Part Number 18666-068) on all connectors. Run the tape between the leads, double back, and finish by stretching the tape and wrapping around the connectors and leads.

WARNING

```

////////////////////////////////////
//
// Do not attempt to operate this pump unless the cable and //
// motor lead connections are properly sealed with underwa- //
// ter tape. Moisture entering the terminal housing could //
// cause a short circuit, resulting in death or injury to //
// personnel and/or damage the pump. //
// //
////////////////////////////////////

```

Apply "Never-Seez" or equivalent compound to the studs (28) of the upper motor housing (23), and position the terminal housing on the motor housing. Install the deformed locknuts (29) and torque to 20 ft. lbs. (240 inch lbs.).

See LUBRICATION and FINAL ASSEMBLY.

LUBRICATION

Check the oil level in the seal cavity and motor housing before initial startup, after the first two weeks of operation, and every month thereafter.

NOTE

To accurately check the oil level the pump must be cool.

The grade of lubricant used is critical to the operation of this pump. Use premium quality hydraulic oil in the grade specified in Table 2.

Table 2. Pump Oil Specifications

Specifications	
Type	Premium high viscosity index, anti-wear hydraulic oil
Neutralization	0.52
Dielectric	26,000(min)
Pour point	-55°F
Recommended supplier	
Gulf Oil Company	Gulf Harmony HVI AW 26

Motor End Seal Cavity

Lay the pump on its side, remove the seal cavity drain/fill plug (58A) in the intermediate, and add approximately 1 1/4 pints of the recommended grade hydraulic oil. Apply "Loctite Pipe Sealant With Teflon #92", or equivalent sealant, to the threads of the drain/fill plug, and reinstall and tighten the plug.

Motor Housing Cavity

With the pump in an upright position, remove the pressure relief valve (30) on top of the pump and add approximately 3 quarts of the recommended grade hydraulic oil. The oil level must be maintained at the midpoint of the reducer bushing (31). Apply "Loctite Pipe Sealant With Teflon #92", or equivalent sealant, to the threads of the pressure relief valve, and reinstall and tighten the valve.

CAUTION

Never attempt to fill the motor lubrication cavity through the drain plug opening (58). An integral oil fill tube is cast into the upper motor housing (located just beneath the pressure relief valve) to prevent over filling of the cavity.

FINAL ASSEMBLY

If the discharge flange (25) has been separated from the motor housing, replace the gasket (24) and secure the flange with nuts (27).

Connect the discharge hose, and position the pump in the sump or wet well. If rigid discharge piping is used, connect the piping after the pump has been positioned. Open any valves in the discharge line.

**For U.S. and International Warranty Information,
Please Visit www.grpumps.com/warranty
or call:
U.S.: 419-755-1280
International: +1-419-755-1352**

**For Canadian Warranty Information,
Please Visit www.grcanada.com/warranty
or call:
519-631-2870**