

**INSTALLATION, OPERATION,  
AND MAINTENANCE MANUAL**  
WITH PARTS LIST



MODEL
<b>S4C1 230V 3P</b>

**THE GORMAN-RUPP COMPANY • MANSFIELD, OHIO**

GORMAN-RUPP OF CANADA LIMITED • ST. THOMAS, ONTARIO, CANADA Printed in U.S.A.

©Copyright by the Gorman-Rupp Company

## TABLE OF CONTENTS

INTRODUCTION . . . . .	I-1
WARNINGS - SECTION A . . . . .	A-1
INSTALLATION - SECTION B . . . . .	B-1
PREINSTALLATION INSPECTION . . . . .	B-1
Lubrication . . . . .	B-2
PUMP INSTALLATION . . . . .	B-2
Pump Specifications . . . . .	B-2
Pump Dimensions . . . . .	B-2
Lifting . . . . .	B-3
Positioning The Pump . . . . .	B-4
Piping . . . . .	B-5
CONTROL BOX INSTALLATION . . . . .	B-6
Enclosure . . . . .	B-6
Dual Voltage Motor Wiring Instructions . . . . .	B-6
Grounding Methods . . . . .	B-9
Field Wiring Connections (Incoming Power) . . . . .	B-10
Pump Power Cable Connections . . . . .	B-11
LIQUID LEVEL DEVICES . . . . .	B-12
OPERATION - SECTION C . . . . .	C-1
CONTROL BOX FUNCTION . . . . .	C-1
Component Function . . . . .	C-1
PUMP OPERATION . . . . .	C-2
Liquid Temperature And Overheating . . . . .	C-2
Checking Pump Rotation . . . . .	C-3
STARTING . . . . .	C-4
Standard Pump (No Liquid Level Devices) . . . . .	C-5
With Automatic Liquid Level Devices . . . . .	C-5
STOPPING . . . . .	C-5
Operation Checks . . . . .	C-6
Cold Weather Preservation . . . . .	C-6
TROUBLESHOOTING - SECTION D . . . . .	D-1
TROUBLESHOOTING CHART . . . . .	D-1
ELECTRICAL TESTING . . . . .	D-4
Test Equipment . . . . .	D-4
Voltage Imbalance . . . . .	D-4
Motor And Motor Power Cable Continuity . . . . .	D-5
Insulation Resistance . . . . .	D-6
MAINTENANCE AND REPAIR - SECTION E . . . . .	E-1
PERFORMANCE CURVE . . . . .	E-1
PUMP MODEL - PARTS LIST . . . . .	E-3
PUMP AND MOTOR DISASSEMBLY AND REASSEMBLY . . . . .	E-4
PUMP END DISASSEMBLY . . . . .	E-5
Strainer Disassembly . . . . .	E-5
Draining Oil From Seal And Motor . . . . .	E-5
Positioning Pump For Disassembly . . . . .	E-5
Impeller Disassembly . . . . .	E-6
Lower Seal Disassembly . . . . .	E-6
Upper Seal Disassembly . . . . .	E-7
PUMP END REASSEMBLY . . . . .	E-7
Cleaning Old Parts . . . . .	E-7
Upper Seal Reassembly . . . . .	E-9
Lower Seal Reassembly . . . . .	E-10
Impeller Reassembly . . . . .	E-11
Diffuser, Wear Plate And Screen Reassembly . . . . .	E-11
MOTOR DISASSEMBLY . . . . .	E-12
Terminal Housing And Power Cable Disassembly . . . . .	E-12

Pump Casing And Motor Housing Disassembly . . . . .	E-13
Rotor Disassembly . . . . .	E-14
Stator Disassembly . . . . .	E-14
Relief Valve . . . . .	E-15
Hoisting Bail . . . . .	E-15
MOTOR REASSEMBLY . . . . .	E-16
Stator Reassembly . . . . .	E-16
Rotor Reassembly . . . . .	E-17
Motor Housing And Pump Casing Reassembly . . . . .	E-18
Terminal Housing And Power Cable Reassembly . . . . .	E-19
Sealing Power Cable With Hot-Melt Adhesive . . . . .	E-19
Sealing Power Cable With Potting Compound . . . . .	E-21
LUBRICATION . . . . .	E-23
Seal Cavity . . . . .	E-24
Motor Housing Cavity . . . . .	E-24
FINAL ASSEMBLY . . . . .	E-24

INTRODUCTION

This Installation, Operation, and Maintenance Manual is designed to help you achieve the best performance and longest life from your Gorman-Rupp pump.

This pump is designed to operate fully or partially submerged. It is capable of handling most nonvolatile and nonflammable liquids which are mildly corrosive and abrasive. The basic material of construction is aluminum with ductile iron or steel wearing parts. The integral dual voltage electric motor must be operated through the control box furnished with the pump. Neither the pump motor nor control box are explosion proof and should not be operated in a hazardous atmosphere.

If there are any questions regarding the pump or motor which are not covered in this manual or in other literature accompanying this unit, please contact your Gorman-Rupp distributor or the Gorman-Rupp Company:

The Gorman-Rupp Company	or	Gorman-Rupp of Canada Limited
P.O. Box 1217		70 Burwell Road
Mansfield, Ohio 44901-1217		St. Thomas, Ontario N5P 3R7

The following are used to alert maintenance personnel to procedures which require special attention, to those which could damage equipment, and to those which could be dangerous to personnel:

NOTE

Instructions to aid in installation, operation, and maintenance or which clarify a procedure.

CAUTION

Instructions which must be followed to avoid causing damage to the product or other equipment incidental to the installation. These instructions describe the requirements and the possible damage which could result from failure to follow the procedures.

WARNING

```

////////////////////////////////////
//                               //
// These instructions must be followed to avoid causing in- //
// jury or death to personnel, and describe the procedure //
// required and the injury which could result from failure //
// to follow the procedure. //
//                               //
////////////////////////////////////

```



WARNINGS

WARNINGS - SECTION A

THESE WARNINGS APPLY TO THE "S-SERIES" SUBMERSIBLE MOTOR OPERATED PUMPS.

WARNING

```

////////////////////////////////////
//
// Before attempting to open or service the pump:
//
// 1. Familiarize yourself with this manual.
// 2. Lock out the motor to the control panel to ensure
//    that the pump will remain inoperative.
// 3. Allow the pump to cool if overheated.
// 4. Close the discharge valve (if used).
//
////////////////////////////////////

```

WARNING

```

////////////////////////////////////
//
// Do not attempt to pump volatile or flammable liquids for
// which this pump has not been designed.
//
////////////////////////////////////

```

WARNING

```

////////////////////////////////////
//
// Before connecting any cable to the control box, be sure
// to ground the control box. See Figure 5 on page B-9 for
// suggested grounding methods.
//
////////////////////////////////////

```

WARNING

```

////////////////////////////////////
//
// After the pump has been installed, make certain that the
// pump and all piping or hose connections are secure be-
// fore operation.
//
////////////////////////////////////

```

WARNING

```

////////////////////////////////////
//
// The pump motor is designed to be operated through the
// control box furnished with the pump. The control box
// provides overload protection and power control. Do not
// connect the pump motor directly to the incoming power
// lines.
//
////////////////////////////////////

```

WARNINGS

WARNING

```

////////////////////////////////////
//
// All electrical connections must be in accordance with
// the National Electric Code and all local codes. If
// there is a conflict between the instructions provided
// and N.E.C. specifications, N.E.C. specifications shall
// take precedence. All electrical equipment supplied with
// this pump was in conformance with N.E.C. requirements in
// effect on the date of manufacture. Failure to follow
// applicable specifications, or substitution of electrical
// parts not supplied or approved by the manufacturer, can
// result in severe injury or death.
//
////////////////////////////////////

```

WARNING

```

////////////////////////////////////
//
// The electrical power used to operate this pump is high
// enough to cause injury or death. Make certain that the
// control box is grounded, and that the power supply is
// compatible with the motor phase and voltage, before con-
// necting the power source. If the overload unit is
// tripped during pump operation, correct the problem be-
// fore restarting the pump.
//
////////////////////////////////////

```

WARNING

```

////////////////////////////////////
//
// Obtain the services of a qualified electrician to con-
// nect the electrical circuits, and to service the control
// box.
//
////////////////////////////////////

```

WARNING

```

////////////////////////////////////
//
// Do not attempt to lift the pump by the motor power cable
// or the piping. Attach proper lifting equipment to the
// hoisting bail fitted to the pump.
//
////////////////////////////////////

```

---

---

## INSTALLATION - SECTION B

This section is intended only to summarize recommended installation practices for the pump and control box. If there are any questions concerning your specific installation, contact your Gorman-Rupp distributor or the Gorman-Rupp Company.

Automatic liquid level devices are not furnished with the standard pump, but are available from Gorman-Rupp as options (see **Liquid Level Devices**, Section B); for information on installing and operating these devices, see the technical data accompanying that option.

### PREINSTALLATION INSPECTION

The pump assembly and control box were inspected and tested before shipment from the factory. Before installation, check for damage which may have occurred during shipment. Check as follows:

- a. Check the pump assembly for cracks, dents, damaged threads, and other obvious damage.
- b. Check for and tighten loose attaching hardware. Since gaskets tend to shrink after drying, check for loose hardware at mating surfaces.
- c. The standard pump is connected to the control box with 50 ft. of power cable. Inspect the cable for cuts or damage.
- d. Check the control box for cracks, dents, and other obvious damage.
- e. Check that all control box components are securely attached to their mounting surfaces, and that the electrical connections are tight and free of corrosion.
- f. Compare the amperes, phase, voltage, and hertz indicated on the motor name plate to the ratings indicated for the control box.
- g. Carefully read all tags, decals, and markings on the pump assembly and the control box, and perform all duties indicated.
- h. Check the pump and motor for any oil leaks. An oil leak may indicate a cut O-ring or other damage.
- i. If the pump and control box have been stored for more than 12 months, some of the components or lubricants may have exceeded their maximum shelf life. These **must be inspected or replaced** to insure maximum pump service.

If the maximum shelf life has been exceeded, or if anything appears to be abnormal, contact your Gorman-Rupp distributor or the factory to determine the repair or updating policy. **Do not** put the pump into service until appropriate action has been taken.

---



---

## Lubrication

There are two lubrication cavities in this pump, both contain premium quality submersible pump oil. The motor housing cavity provides lubrication to the motor assembly and rotor shaft bearings. The intermediate cavity provides lubrication to the seal assembly.

There are two shaft seals in this pump. The lower seal prevents liquid from entering the intermediate cavity at the impeller end. The upper seal prevents oil leakage from the motor housing cavity and acts as back-up protection in the event of lower seal failure.

Both cavities are fully lubricated when the pump is shipped from the factory. Check lubrication levels before installing the pump (see **LUBRICATION in MAINTENANCE AND REPAIR**). An additional quart of oil has been provided with the pump to "top off" the oil cavities. If either oil level is abnormally low, determine the cause before putting the pump into service.

## PUMP INSTALLATION

### Pump Specifications

See Table 1 for the typical pump specifications and motor data.

**Table 1. Pump Specifications**

Model Number	Voltage/Phase	Pump Horsepower	Motor Speed (RPM)	Full Load Amperes	No Load Amperes	Locked Rotor Amperes	Discharge Size (NPT)
S4C1	230/3	10	3450	34	7	148	4
S4C1	460/3	10	3450	17	3.5	74	4

### Pump Dimensions

The standard pump is provided with a suction strainer to prevent large solids from clogging the impeller. On high discharge head applications, the strainer can be replaced with an optional staging adaptor to allow one pump to feed another.

See Figure 1 on page B-3 for the approximate physical dimensions of the pump.

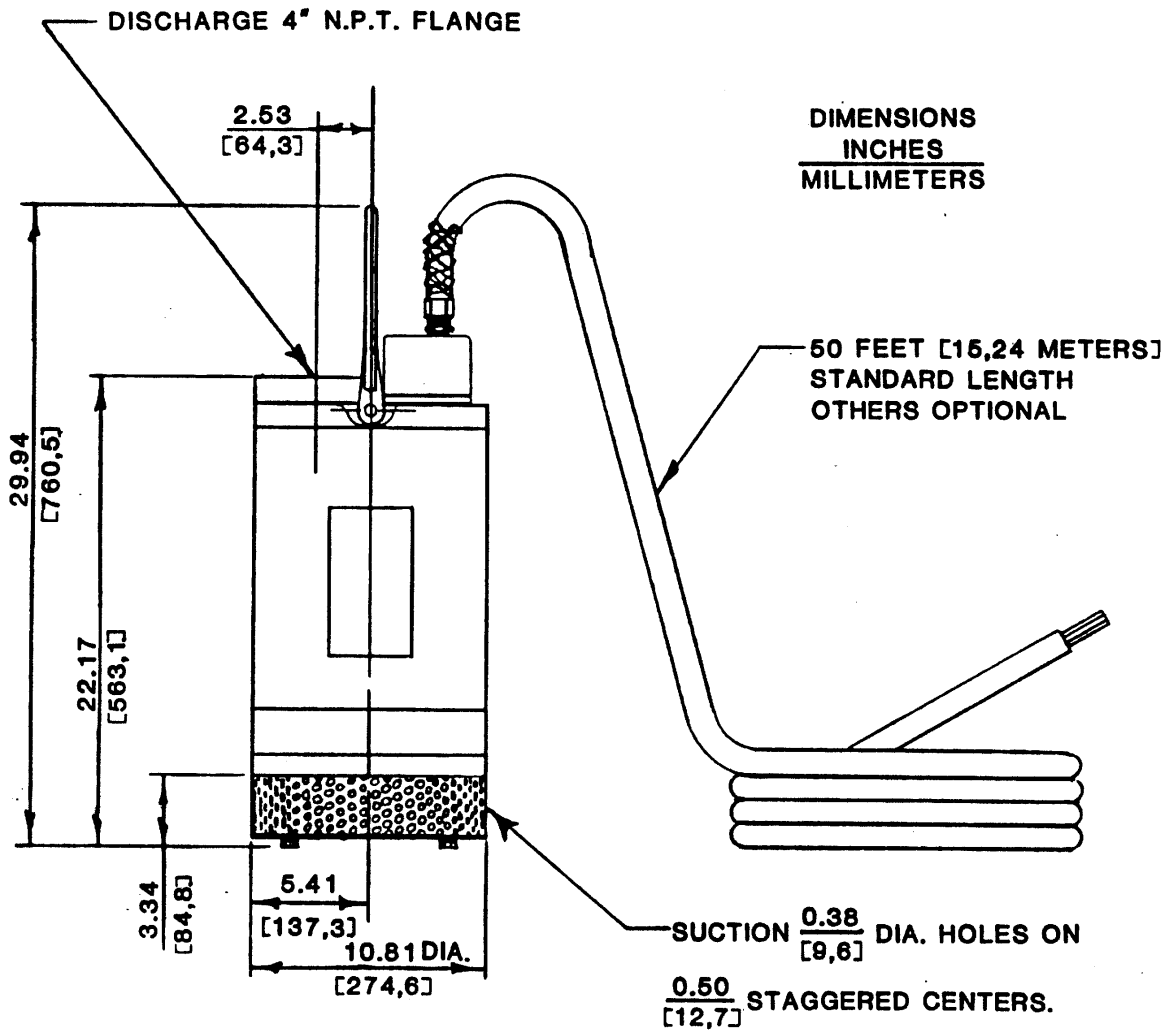

Figure 1. Pump Model S4C1 230V 3P

Lifting

Use lifting equipment with a capacity of at least 1,000 pounds. This pump weighs approximately 190 pounds, not including the weight of accessories and control box. Customer installed equipment such as rigid piping **must** be removed before attempting to lift.

---

---

**WARNING**

```
////////////////////////////////////  
//  
// Do not attempt to lift the pump by the motor power cable //  
// or the piping. Attach proper lifting equipment to the //  
// hoisting bail fitted to the pump. If chains or cable //  
// are wrapped around the pump to lift it, make certain //  
// that they are positioned so as not to damage pump, and //  
// so that the load will be balanced. //  
// //  
////////////////////////////////////
```

**Positioning The Pump**

This pump is designed to operate fully or partially submerged. It may also be operated in air for extended periods. The rotating parts are oil lubricated, and the motor is cooled by a constant flow of liquid or air discharged through internal passage(s).

The pump will operate if positioned on its side, but this is not recommended because the motor torque could cause the pump to roll during operation.

The pump should be independently secured and supported by the hoisting bail. If the application involves a lot of debris, protect the pump from excessive wear and clogging by suspending it in a perforated barrel or culvert pipe. If the bottom is heavily sludge-covered, rest the pump on support blocks or suspend it from a raft or similar device near the surface of the liquid. See Figure 2 on page B-5 for typical pump installations.

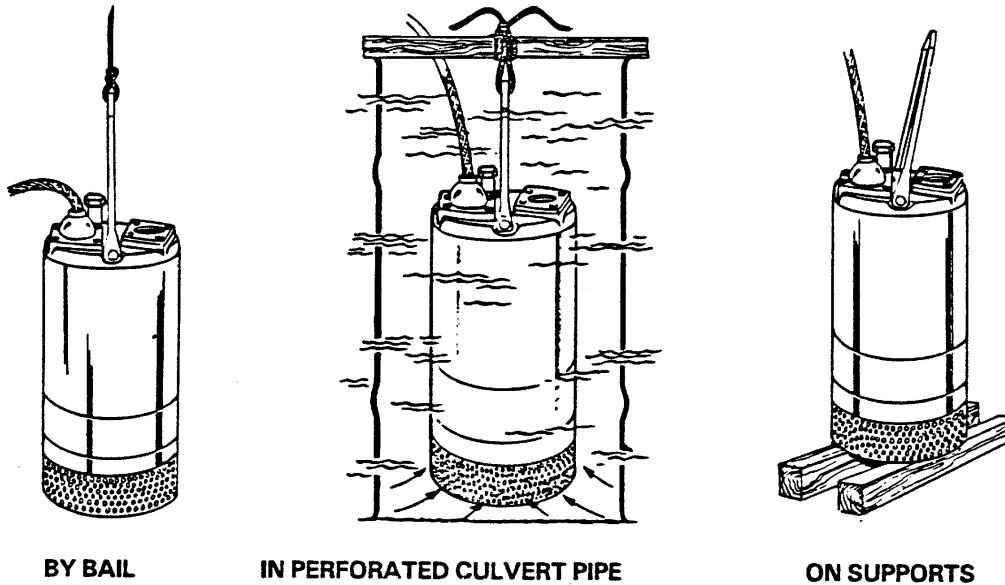

Figure 2. Typical Pump Installations.

All liquid entering the pump must pass through a strainer screen. Any spherical solids which pass through the screen will pass through the pump.

#### NOTE

Before actual operation, check the direction of impeller rotation to ensure that the pump is properly wired to the control box. See **Checking Pump Rotation** in **OPERATION** section.

#### Piping

No suction piping is required in a standard submerged application.

If an optional suction staging adaptor is installed, the discharge from one pump may be piped to the suction of another. To determine the size of the discharge connection, see Table 1, **PUMP SPECIFICATIONS**. Either hose or rigid pipe may be used. To facilitate mobility and maintenance, it is recommended that the discharge line be fitted with a quick disconnect fitting near the pump. The discharge line must be independently supported to avoid strain and vibration on the pump.

For maximum pumping capacity, keep the discharge as short and straight as possible. Minimize the use of elbows and fittings which increase friction losses through the discharge piping system.

It is recommended that a check valve or throttling valve be installed in the discharge line to control siphoning or back flow when the pump is shut off.

**CONTROL BOX INSTALLATION**

This pump is driven by an integral 230 VAC, 60 hertz, 3 phase, 10 HP motor. It is designed to operate through the control box furnished with the pump.

**WARNING**

```

////////////////////////////////////
//
// The pump motor is designed to be operated through the //
// control box furnished with the pump. The control box //
// provides overload protection and power control. Do not //
// connect the pump motor directly to the incoming power //
// lines. //
// //
////////////////////////////////////

```

**Enclosure**

The control box is a rainproof enclosure with a padlockable front cover. **The enclosure is not designed to be watertight, and should not be submerged.** See Figure 4 on page B-8 for enclosure dimensions and callouts.

Secure the control box vertically on a level surface, which is above flood level. It should be easily accessible to the operator, and located close enough to the pump to avoid excessive voltage drop due to cable length. (See **Pump Power Cable Connections**). After the box is installed, make certain the front cover latches properly.

**CAUTION**

<p>Failure to mount the control box vertically on a level surface may affect operation of the pump controls.</p>
--

**Dual Voltage Motor Wiring Instructions**

This pump is powered by a dual-voltage motor which permits utilization of high or low voltage. The motor was originally wired and shipped for the voltage indicated as "Factory Wired" on the pump's name plate. The name plate also indicates the dual voltages pertaining to this motor. If the alternate voltage must be utilized, certain wiring and control box modifications are required.

INSTALLATION

The control box assembly provided with this pump has been designed to accommodate **only** the voltage indicated on the front of the box. This voltage coincides with the "Factory Wired" voltage of the motor. If the alternate voltage is utilized, the control box must be replaced with another box designed for the appropriate voltage. Consult the Parts List under Options (Section E, Page 3) to determine the part number of the alternate control box.

The motor wiring **must** also be changed before utilizing the alternate voltage. For detailed instructions on disassembly and reassembly of the terminal housing, see **Terminal Housing and Power Cable Disassembly** and **Terminal Housing and Power Cable Reassembly** in this manual (Section E). Change the motor leads as indicated on the wiring diagram plate affixed to the side of the terminal housing, see Figure 3. Be sure to tag the revised voltage on the pump.

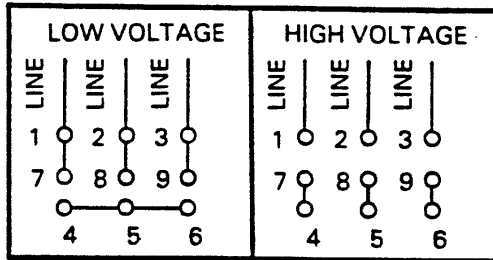

Figure 3. Motor Wiring Diagram

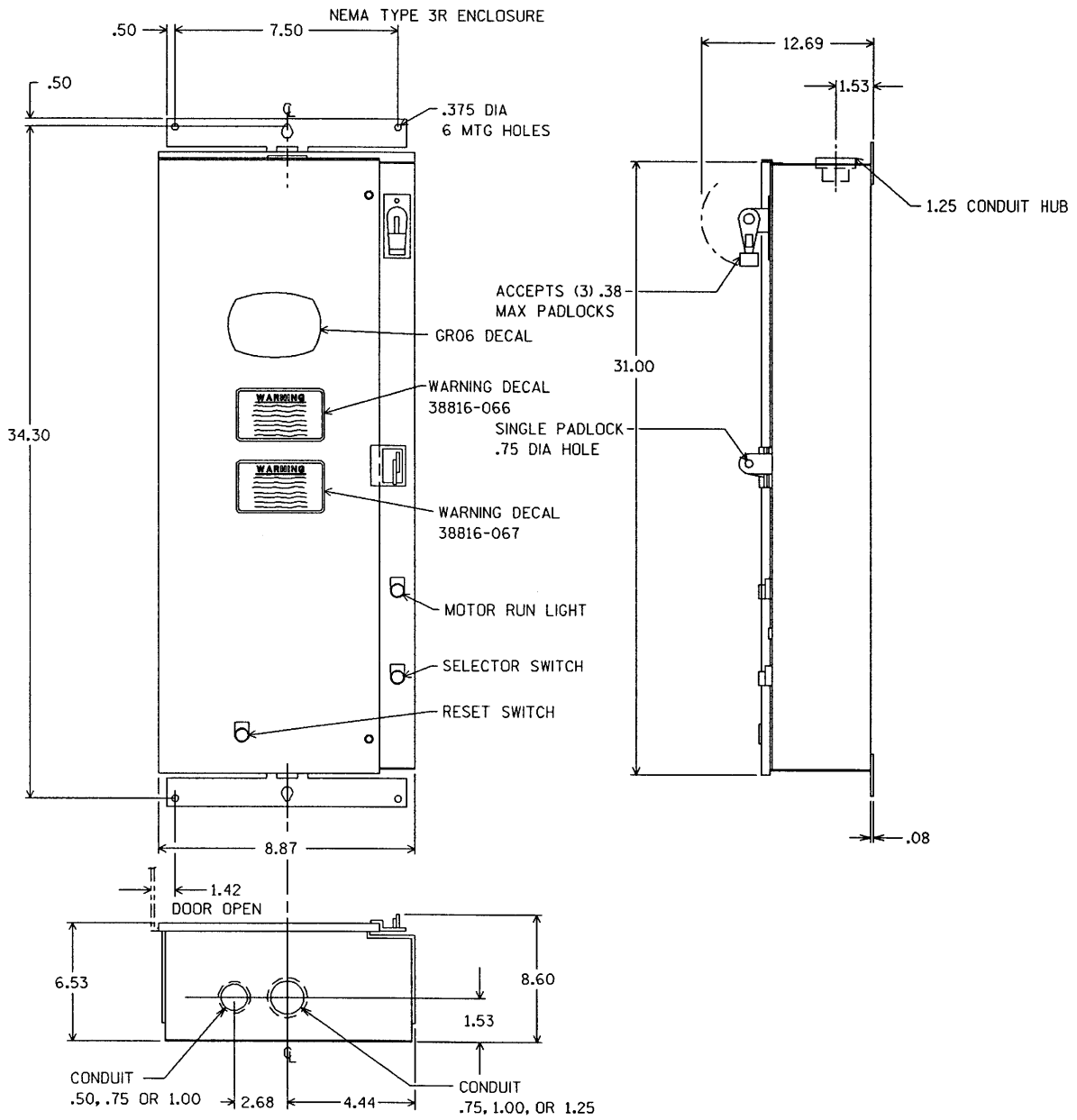

Figure 4. 27515-504 Control Box Assembly

## Grounding Methods

Electrically ground the installation before connecting the field wiring to the control box. Install a grounding terminal to the enclosure and connect it to a properly imbedded electrode.

The material used for the electrode **must** be an excellent conductor of electricity, such as copper. If iron or steel is used, it must be galvanized or otherwise metal plated to resist corrosion. **Do not** coat the electrode with any material of poor conductivity such as paint or plastic.

The electrode must conform to the recommendations of N. E. C. Article 250. Follow all installation requirements of the N.E.C., and all applicable local codes. See Figure 5 for some suggested grounding methods.

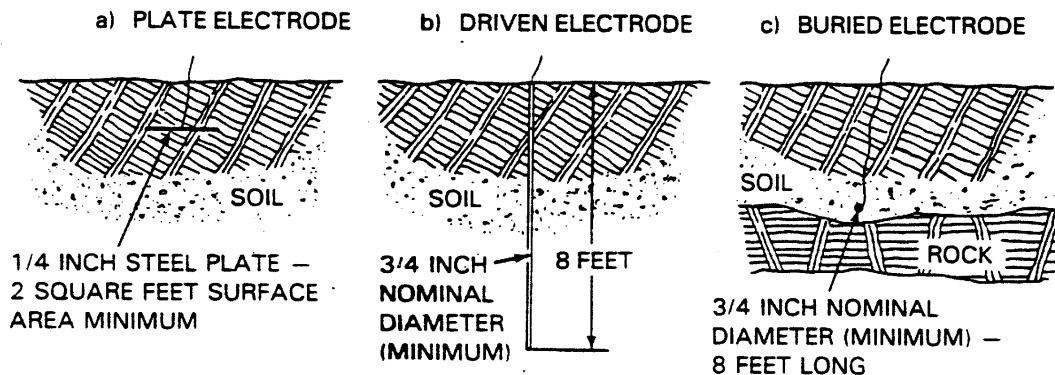

Figure 5. Suggested Grounding Methods

- a. **Plate Electrode:** An iron or steel plate, 1/4 inch thick, completely imbedded in the ground. The plate must present a surface of a least 2 square feet.
- b. **Driven Electrode:** A rod or pipe, 3/4 inch diameter minimum, 8 feet long, completely driven into the ground.
- c. **Buried Electrode:** If rock or stone prevents imbedding the full 8 foot length of the ground rod, bury it in a horizontal trench.

Space the ground rod or plates at least 6 feet from any other electrode or ground rod, such as those used for signal circuits, radio grounds, lightning rods, etc.

The earth surrounding the ground rod or plate **must** contain enough moisture to make a good electrical connection. In dry or sandy areas, pour water around the rod or consult qualified personnel to devise a method of improving the connection.

**WARNING**

```

////////////////////////////////////
//
// The electrical power used to operate this pump is high //
// enough to cause injury or death. Make certain that the //
// control box is properly grounded after installation. //
//
////////////////////////////////////

```

**Field Wiring Connections (Incoming Power)**

**WARNING**

```

////////////////////////////////////
//
// The electrical power used to operate this pump is high //
// enough to cause injury or death. Obtain the services of //
// a qualified electrician to make all electrical con- //
// nections. Make certain that the pump and enclosure are //
// properly grounded, and that the incoming power matches //
// the requirements of the pump and control. //
//
////////////////////////////////////

```

The pump control is designed to regulate a 230 volt, 3 phase, 60 hertz power supply. The field wiring must be properly sized to insure an adequate voltage supply. The voltage available **at the motor** must be within the range indicated in Table 2.

To calculate the voltage available at the motor proceed as follows:

- a. Measure the incoming voltage across lines (1 & 2, 2 & 3, and 1 & 3.) while the pump is **operating at full capacity**. See Figure 7 on page B-14 or Figure 8 on page B-15..
- b. Next, subtract the motor cable voltage drop (see Table 3, Motor Cable Specifications).
- c. Do not continue to operate the pump if this voltage is not within the recommended limits. Obtain the services of a qualified electrician to determine the correct field wiring size and other details to insure an adequate voltage supply to the pump.

**Table 2. Pump Motor Voltage Limits**

Nominal Voltage	Phase	Minimum Voltage	Maximum Voltage
230	3	210	250
460	3	420	500

INSTALLATION

Use conduit or cable clamps to secure the incoming field wiring to the control box. Make certain all connections are tight and that cable entry points are rainproof. Support the cable weight, if required, to prevent excessive strain on cable clamps and cable.

Pump Power Cable Connections

WARNING

Warning text enclosed in slashes: The electrical power used to operate this pump is high enough to cause injury or death. Make certain that incoming power is OFF and LOCKED OUT before connecting power or accessory cables to the control box. Obtain the services of a qualified electrician to make all electrical connections.

The standard pump is provided with a 50-foot power cable sealed by heat-shrink tubing in the terminal housing assembly. (See Table 3 for cable specifications.) If a longer power cable is required, an optional cable assembly must be ordered from the factory. Splicing of the power cable is not recommended by the Gorman-Rupp Company due to safety and warranty considerations.

WARNING

Warning text enclosed in slashes: Never attempt to alter the length or repair any power cable with a splice. The pump motor and cable must be completely waterproof. Injury or death may result from alterations.

Table 3. Cable Requirements for Pump Electrical Connections, Model S4C1

Table with 7 columns: Voltage/Phase, A.W.G. Cable Size, Cable OD (inches), Conductor Dia. (inches), Amp Rating\* at 40°C (amperes), DC Resistance at 25°C (ohms/1000 ft), Voltage Drop at Max. Load per 100 ft. Rows include 230/3 and 460/3 configurations.

\*Applies only to GGC type cable. Refer to manufacturer's specifications for other cable.

Before connecting the pump power cable to the control box, make certain the incoming power is OFF and LOCKED OUT. Make certain the control box is PROPERLY GROUNDED and that the electrical data on the control matches the motor name plate data.

---

---

Connect the pump power cable to the control box as shown in Figure 7 on page B-14 or Figure 8 on page B-15.. Use conduit or cable clamps to secure the power and accessory cables to the control box. Make certain that all connections are tight and that cable entry points are rainproof.

#### NOTE

The power cable furnished with this pump includes three electrical conductors (white, red, and black), two grounding conductors (green) and one ground check conductor (yellow). The yellow ground check lead is used in conjunction with customer supplied ground monitoring equipment. If this equipment is not used, the yellow lead should be connected with the green leads and used as a ground conductor.

#### LIQUID LEVEL DEVICES

The standard pump is **not** furnished with a means to automatically regulate liquid level. However, the pump may be controlled to perform filling, or dewatering functions by using **either** of the following optional sensing devices: (see Figure 6 on page B-13).

- **Diaphragm Type:** two fixed position sensors (upper and lower) each contain a diaphragm which flexes with changes in liquid level, thus activating an enclosed miniature switch.
- **Bulb (Float) Type:** a bulb raises or lowers (floats) with the liquid level, thus activating an enclosed miniature switch.

For added safety, the sensing devices operate through low voltage (24 volt) circuitry which is specially designed to fit into the main pump control box.

The circuitry may be prewired as a factory option, or easily added in the field by qualified personnel. For installation and operation, see the detailed instructions included with the optional package.

#### CAUTION

Liquid level devices **MUST** be positioned far enough apart to allow 10 minutes between starts. If the pump motor cycles more than 6 starts per hour, it will overheat resulting in damage to the motor windings or control box components.

TYPICAL INSTALLATION

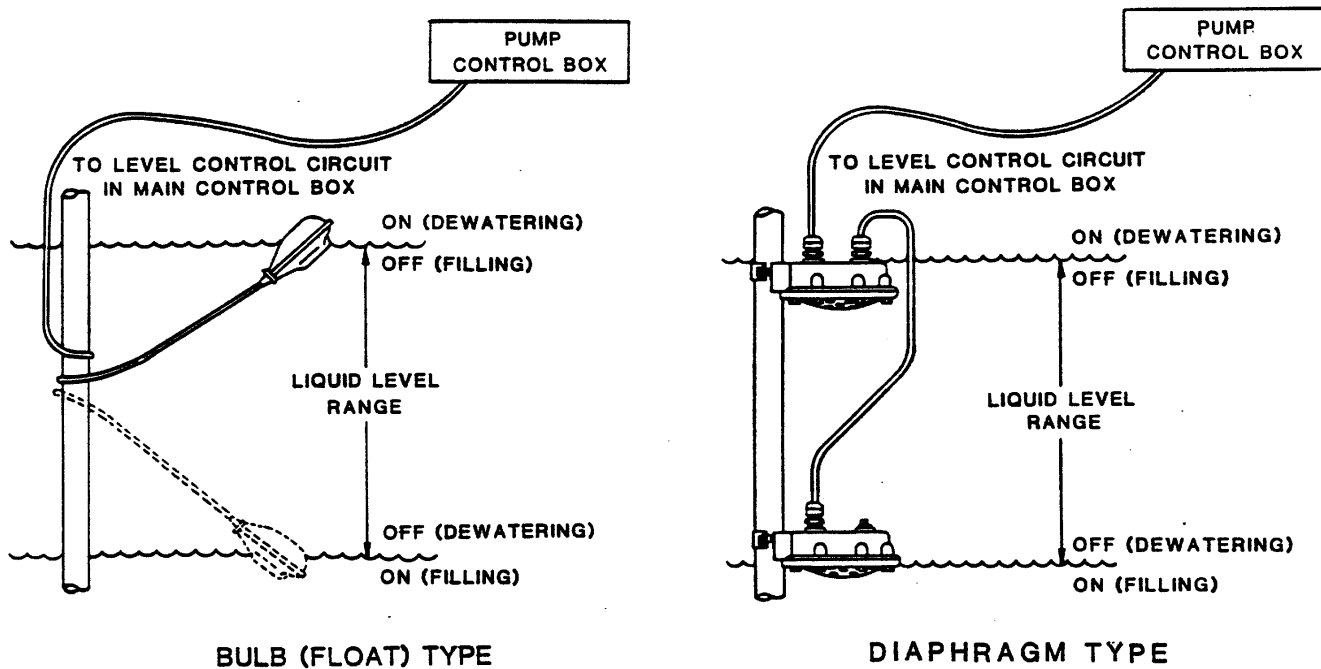

Figure 6. Liquid Level Devices

CAUTION

The internal wiring of the sensing devices are different for filling and dewatering functions. Be sure to follow the instructions included with the option before making wiring connections.

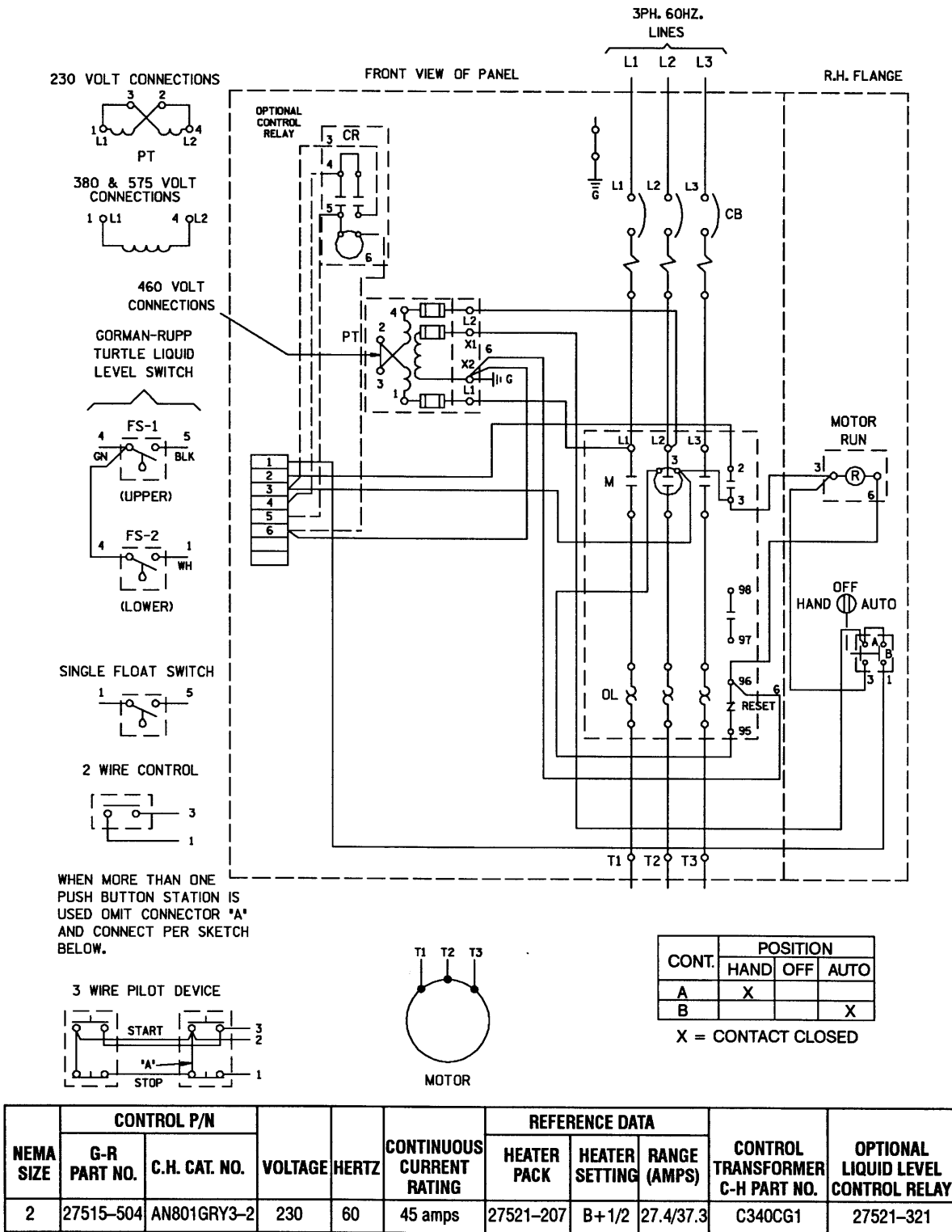

Figure 7. Magnetic Controller Connection Diagram For Control Box 27515-504

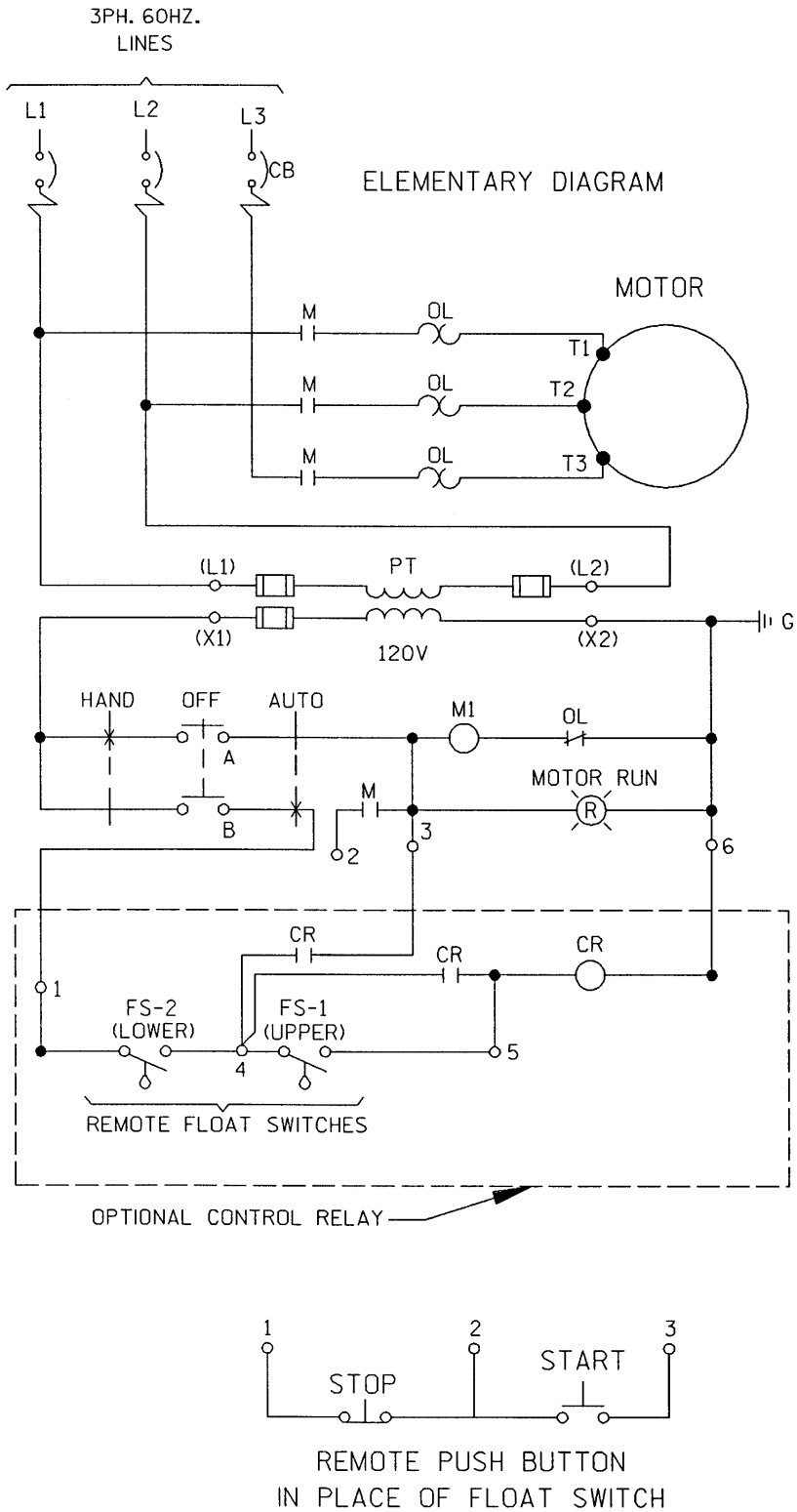

Figure 8. Magnetic Controller Elementary Diagram Based On Figure 7 on page B-14

**REPAIR PARTS LIST, INTERNAL PARTS  
27515-504 CONTROL BOX ASSEMBLY**

(Unless Otherwise Specified, Components Identified By Cutler Hammer Part Numbers)

ITEM NO.	PART NAME	PART NUMBER	QTY
1	CIRCUIT BREAKER - 50 AMP	C370HMCP2	1
2	MOTOR STARTER	AN16GNOA	1
3	CONTACTOR - 3 POLE	CN15GN3A	1
4	RENEWAL CONTACT SET	6-65-8	1
5	COIL	9-2703-1	1
6	OVERLOAD RELAY	C306GN3	1
7	HEATER PACK (G-R PART NUMBER)	27521-207	1
8	CONTROL TRANSFORMER	C340CG1	1
9	"MOTOR RUN" PILOT LIGHT	10250T34R	1
10	"MOTOR RUN" LEGEND PLATE	10250TM81	1
11	TERMINAL BLOCK	80-5817	2
12	H-O-A SELECTOR SWITCH	10250T21KB	1
13	"HAND-OFF-AUTO" LEGEND PLATE	10250TM51	1

OPERATION - SECTION C

CONTROL BOX FUNCTION

WARNING

```

////////////////////////////////////
//
// This pump motor and control box are not designed to be //
// explosion proof. Do not operate in an explosive atmos- //
// phere. //
// //
////////////////////////////////////

```

A control box is provided to facilitate operation of the pump. It contains controls for starting and stopping the pump, and provides overload protection for the pump motor. The pump control may be equipped with an optional automatic liquid level sensing device, in which case the low voltage circuits are also contained within the control box.

WARNING

```

////////////////////////////////////
//
// The pump motor is designed to be operated through the //
// control box furnished with the pump. The control box //
// provides overload protection and power control. Do not //
// connect the pump motor directly to the incoming power //
// lines. //
// //
////////////////////////////////////

```

CAUTION

Since operation of the pump motor is dependent upon the quality and performance of the electrical controls, the pump warranty is valid only when controls have been specified or provided by the Gorman-Rupp Company.

Component Function

The control box contains the following hand operated switches and controls:

- The **control handle** operates the control box circuit breakers. In the OFF position, the control handle opens the circuit breakers to interrupt incoming power through the control box and prevent pump operation. In the ON position, it closes the circuit breakers to permit pump operation. The circuit breakers will open or "TRIP" automatically in the event of a short circuit overload current, or thermal excess within the pump motor or electrical system. When tripped, move the control handle to OFF and back to ON to reset the circuit breakers.

OPERATION

- The **selector switch** (optional on some boxes) controls the mode of operation. In the OFF position, it prevents all operation of the pump. In the HAND position, it allows the pump to run continuously. In the AUTO position, it allows the pump to be controlled automatically by the optional liquid level control system, if used.
- The **RESET** pushbutton resets the motor overload relay after it has been "TRIPPED" by an overload. The overload relay will trip automatically if the current drawn by the motor exceeds design specifications.

NOTE

If the overload unit trips, do not reset it immediately. Wait at least ten minutes before resetting the control handle back to the ON position. If the overload unit continues to trip, operational problems exist. See **TROUBLESHOOTING**.

WARNING

```

////////////////////////////////////
//
// The motor will restart as soon as the RESET pushbutton //
// is pressed, unless the selector switch is in the OFF po- //
// sition. Turn the selector switch to OFF and move the //
// control handle to OFF before approaching the pump. //
// //
////////////////////////////////////

```

- The **liquid level devices** (optional equipment) operate in conjunction with the 3-position switch (HAND-OFF-AUTO) supplied as a part of that option. After the level sensors and circuitry have been installed, pump operation may be automatically controlled for filling or dewatering functions. (See **LIQUID LEVEL DEVICES**, Section B.)

PUMP OPERATION

WARNING

```

////////////////////////////////////
//
// This pump is designed to handle most non-volatile and //
// non-flammable liquids which may be mildly corrosive or //
// abrasive Do not attempt to pump liquids which may dam- //
// age the pump or endanger personnel as a result of pump //
// failure. //
// //
////////////////////////////////////

```

Liquid Temperature And Overheating

The **maximum** liquid temperature for this pump is 120°F. Do not apply it at a higher operating temperature.

OPERATION

Overheating can occur if the pump is misapplied, required to start repeatedly, or if the control box fails to provide adequate protection. Operating the pump against a closed discharge for extended period will also cause the pump to over-heat.

As a safeguard against rupture or explosion due to heat, this pump is equipped with a pressure relief valve which will open if vapor pressure within the pump motor reaches a critical point. If overheating does occur, stop the pump immediately and allow it to cool before servicing it. **Approach any overheated pump cautiously.**

WARNING

```

////////////////////////////////////
//                               //
// Overheated pumps can cause severe burns and injury. If //
// overheating of the pump occurs:                               //
//                               //
//     1. Stop the pump immediately.                            //
//     2. Allow the pump to cool.                               //
//     3. Refer to instructions in this manual before re-    //
//         starting the pump.                                   //
//                               //
////////////////////////////////////

```

It is recommended that the pressure relief valve assembly be replaced at each overhaul, or any time the pump motor overheats and activates the valve. **Never** replace this valve with a substitute which has not been specified or provided by the Gorman-Rupp Company.

Checking Pump Rotation

Check the direction of pump rotation before operation to ensure that the impeller is rotating in the correct direction.

Suspend the pump from the hoisting bail. Turn it on momentarily and note the direction of twist. For correct rotation and operation, the twist must be in the **counterclockwise** direction when viewed from the **top**.

CAUTION

<p>Secure the pump during rotation check to prevent coiling of the power cable.</p>
---

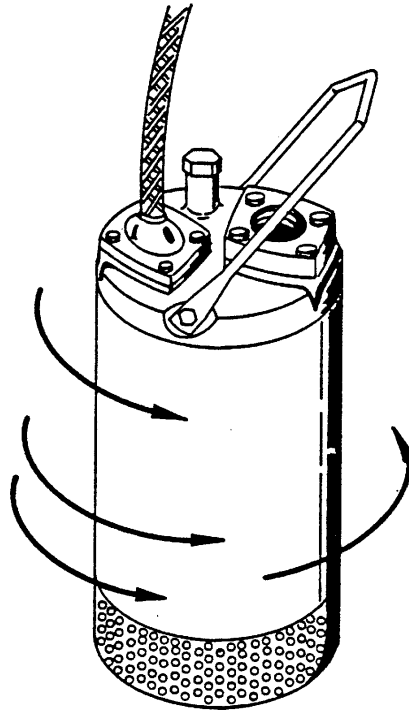

Figure 1. Checking Pump Rotation

If the pump twists clockwise on start, interchange any two motor leads at the control box.

**WARNING**

```

////////////////////////////////////
//
// The electrical power used to operate this pump is high //
// enough to cause injury or death. Make certain that in- //
// coming power is OFF and LOCKED OUT before interchanging //
// motor leads. //
// //
////////////////////////////////////

```

**STARTING**

After the pump and control box have been installed, start the pump as follows.

**NOTE**

Before actual operation, check the direction of impeller rotation to ensure that the pump is properly wired. See **Checking Pump Rotation** in **OPERATION** section.

---

---

**CAUTION**

Never start the pump more than 6 times per hour. If the motor does not cool between starts, it will overheat resulting in damage to the motor windings or control box components.

**Standard Pump (No Liquid Level Devices)**

If no liquid level devices have been installed, move the control handle to the ON position and turn the selector switch to HAND. The pump motor will start and pumping should begin.

The pump will continue to operate until it is stopped by turning the selector switch to OFF.

**With Automatic Liquid Level Devices**

If optional liquid level devices have been installed, move the 3-position selector switch to OFF and the control handle to the ON position.

If desired to operate the pump in the manual mode, set the selector switch to HAND; the pump will continue to run until the switch is returned to OFF, or reset to AUTO.

If desired to operate the pump in the automatic mode, set the selector switch to AUTO; pump operation will be maintained by the optional liquid level control system. To terminate automatic mode, move the selector switch to OFF or HAND.

**STOPPING**

To stop pump operation, turn the control handle OFF.

Power through the control box may be terminated by moving the control handle to the OFF position, thereby opening the circuit breakers. This **does not** terminate incoming power through the field wiring connected to the control box.

After stopping the pump, be sure to perform all required maintenance and preservation procedures.

**NOTE**

It is recommended that a check valve or throttling valve be installed in the discharge line if there is any possibility of siphoning or back flow when the pump is shut off.

Operation Checks

Check the pump for proper operation when it is first started and periodically thereafter to identify minor problems.

Check the pump for unusual noises or excessive vibration while it is operating. If noise or vibration is excessive, stop the pump and refer to the troubleshooting chart for possible causes.

Check the pump strainer screen for clogging caused by stones, sticks, or other debris. Clean the strainer screen when required. In some cases, stopping the pump momentarily may back flush the strainer screen, purging most of the debris from it. If this fails to clean the screen, remove the pump from the sump and remove the debris manually. See **PUMP DISASSEMBLY**.

**Never** introduce air or steam pressure into the pump casing or piping to remove a blockage. This could result in personal injury or damage to the equipment. If backflushing is absolutely necessary, **liquid pressure** must be limited to 50% of the maximum permissible operating pressure shown on the pump performance curve.

Check the pump for overheating. The pump could overheat if operated against a closed discharge valve, or subjected to repeated start cycles.

Cold Weather Preservation

In freezing temperatures, the pump will not freeze as long as it is submerged in liquid. If the pump casing is not submerged, or if the liquid begins to freeze, remove the pump from the sump or wet well and allow it to dry thoroughly. Run the pump for two or three minutes to dry the inner walls.

If the pump freezes, move it into a warm area until completely thawed, or submerge it into the liquid. If the liquid is near freezing, the pump must be submerged for an extended period of time. Start the pump and check for shaft rotation. If still frozen, allow additional thawing time before attempting to restart.

**WARNING**

```

////////////////////////////////////
//
// Do not attempt to thaw the pump by using a torch or oth- //
// er source of flame. This could damage gaskets or heat //
// the oil within the pump above the critical point and //
// cause the pump to rupture or explode. //
// //
////////////////////////////////////

```



TROUBLE	POSSIBLE CAUSE	PROBABLE REMEDY
PUMP FAILS TO START, OVERLOAD UNIT NOT TRIPPED (AUTOMATIC MODE) (cont.)	<p>Float type sensing device(s) tangled or obstructed.</p> <p>Defective liquid level sensing device(s) or control panel.</p>	<p>Check installation for free movement of float.</p> <p>Repair or replace defective unit(s).</p>
OVERLOAD UNIT TRIPS	<p>Low or high voltage, or excessive voltage drop between pump and control box.</p> <p>Defective insulation in motor windings or power cable; defective windings.</p> <p>Impeller jammed due to debris or insufficient clearance.</p> <p>Bearing(s) frozen.</p> <p>Terminal housing incorrectly wired. (Dual voltage or single phase motors only).</p>	<p>Measure voltage at control box. Check that wiring is correct type, size, and length. (See Field Wiring Connection, Section B).</p> <p>Check insulation resistance; check continuity.</p> <p>Disassemble pump and check impeller.</p> <p>Disassemble pump and check bearing(s).</p> <p>Check terminal housing internal connections against motor wiring plate and schematic wiring diagram.</p>
MOTOR RUNS, BUT PUMP FAILS TO DELIVER RATED DISCHARGE	<p>Discharge head too high.</p> <p>Low or incorrect voltage.</p> <p>Discharge throttling valve partially closed; check valve installed improperly.</p> <p>Discharge line clogged or restricted; hose kinked.</p> <p>Liquid being pumped too thick.</p> <p>Strainer screen or impeller clogged.</p>	<p>Reduce discharge head, or install staging adaptor and additional pump.</p> <p>Measure control box voltage, both when pump is running and when shut off.</p> <p>Open discharge valve fully; check piping installation.</p> <p>Check discharge lines; straighten hose.</p> <p>Dilute liquid if possible.</p> <p>Clear clog(s). Stop pump; back flow may flush away debris.</p>

TROUBLE	POSSIBLE CAUSE	PROBABLE REMEDY
MOTOR RUNS, BUT PUMP FAILS TO DELIVER RATED DISCHARGE (cont.)	Insufficient liquid in sump or tank.  Worn impeller vanes; excessive impeller clear- ance.  Pump running backwards.	Stop pump until liquid level rises.  Check impeller and clearance. See PUMP END REASSEMBLY.  Check direction of rotation and correct by interchanging any two motor leads at control box. (See Pump Rotation, Section C).
PUMP RUNS WITH EXCES- SIVE NOISE OR VIBRATION	Pumping entrained air.  Damaged or unbalanced impeller.  Discharge piping not properly supported.  Impeller jammed or loose.  Motor shaft or bearings defective.  Pump cavitation.	Check liquid level in sump; check position of pump and liquid level sensing device(s).  Replace impeller.  Check piping installation.  Check impeller.  Disassemble pump and check motor and bearings.  Reduce discharge head, or restrict flow on low head appli- cations.

**ELECTRICAL TESTING**

If you suspect that pump malfunctions are caused by defects in the motor, power cable or control box, perform the following checks to help isolate the defective part.

**WARNING**

```

////////////////////////////////////
//
// The electrical power used to operate this pump is high //
// enough to cause injury or death. Obtain the services of //
// a qualified electrician to troubleshoot, test and/or //
// service the electrical components of this pump. //
//
////////////////////////////////////
    
```

**CAUTION**

Be certain to refer to the wiring diagram(s) in the INSTALLATION section of this manual before reconnecting any electrical components which have been disconnected.

**Test Equipment**

A volt/amp/ohmmeter and megohmmeter of adequate range and quality will be required to conduct the following electrical tests. The suggested equipment indicated below is commercially available, or an equivalent substitute may be used.

Equipment	Manufacturer	Use
Amprobe Model 300 or Amprobe, Jr.	Pyramid Instrument Corp. Lynbrook, NY	To check AC Voltage and current (amperage)
Megohmer	Herman H. Sticht Co. 25 Bark Place New York, N.Y.	To measure resistance (ohms) to ground

**Voltage Imbalance**

Each phase of the incoming three-phase power must be balanced with the other two as accurately as a commercial voltmeter will read. If the phases are balanced, check out the motor as described below. If the phases are out of balance, contact your power company and request that they correct the condition.

## TROUBLESHOOTING

- 
- 
- a. Use a voltmeter, Amprobe, or equivalent meter to read the voltage across terminals 1 & 2, 2 & 3, and 1 & 3. in the control box. All three measured voltages must be the same, as accurately as the meter will read. If possible, measure the voltage with the pump off, with the pump running but out of the water, and with the pump running in the water at full load. All the measured voltages at each condition must be the same.
  - b. Use an Amprobe or equivalent meter to measure the current draw of each phase while the pump is running at full load and at no load. All three amperage readings must be the same at each condition, as accurately as the meter will read. Nominal amperage values are listed in Table 1, but these apply only when the actual voltage at the site is the nominal voltage listed.
  - c. If the voltages are balanced with the pump off, but are unbalanced when the pump is running, a thorough check of the power source, all interconnecting cables, and the pump motor is required to isolate the defect.

## Motor And Motor Power Cable Continuity

To check continuity, zero-balance the ohmmeter set at the RX1 scale, and test as follows:

- a. Disconnect the motor power cable leads from the control box and connect the test leads to any two of the three power cable leads (not to the green ground lead or yellow ground check lead). If there is a high resistance reading on the ohmmeter, there is an open or broken circuit caused by a break in the power cable or motor windings, or by a bad connection between the motor and the power cable. Switch one test lead to the third power lead, and test again.
- b. If an open or broken circuit is indicated, check the power cable for obvious damage, and replace as necessary (see **MAINTENANCE AND REPAIR**). If there is no apparent damage to the motor cable, remove the terminal housing (see **MAINTENANCE AND REPAIR**) and check the continuity of each power cable lead at the terminal posts.
- c. If an open circuit still exists after each lead (terminal) has been tested and tightened, then the **entire** motor power cable must be replaced. Splicing or other means of repair are not recommended.
- d. If no break is found in the power cable, check the motor leads for continuity. If the test reading indicates an open or broken circuit, there is an open circuit in the motor.

## NOTE

It is recommended that a pump with a defective motor be returned to Gorman-Rupp, or to one of the Gorman-Rupp authorized Submersible Repair Centers.

---

---

### Insulation Resistance

To check insulation, zero-balance the ohmmeter set at the RX100K scale, and test as follows:

- a. Disconnect the motor power cable leads from the control box. Connect one test lead to the power cable green ground lead, and touch the other test lead to each of the three power leads in turn.
- b. The reading obtained will indicate resistance values in both the power cable and the motor windings. If the resistance reading is infinity ( $\infty$ ), the insulation is in good condition. If the reading is between infinity ( $\infty$ ) and 1 megohm, the insulation is acceptable but should be rechecked periodically. If the reading is less than 1 megohm, the insulation should be checked more closely; a reading of zero indicates that the power cable or the motor is grounded.
- c. To determine whether the power cable or the motor is grounded, remove the terminal housing (see **MAINTENANCE AND REPAIR**), disconnect the motor leads from the motor terminals, and test the power cable leads and motor leads separately.

## PUMP MAINTENANCE AND REPAIR - SECTION E

**MAINTENANCE AND REPAIR OF THE WEARING PARTS OF THE PUMP WILL MAINTAIN PEAK OPERATING PERFORMANCE.**

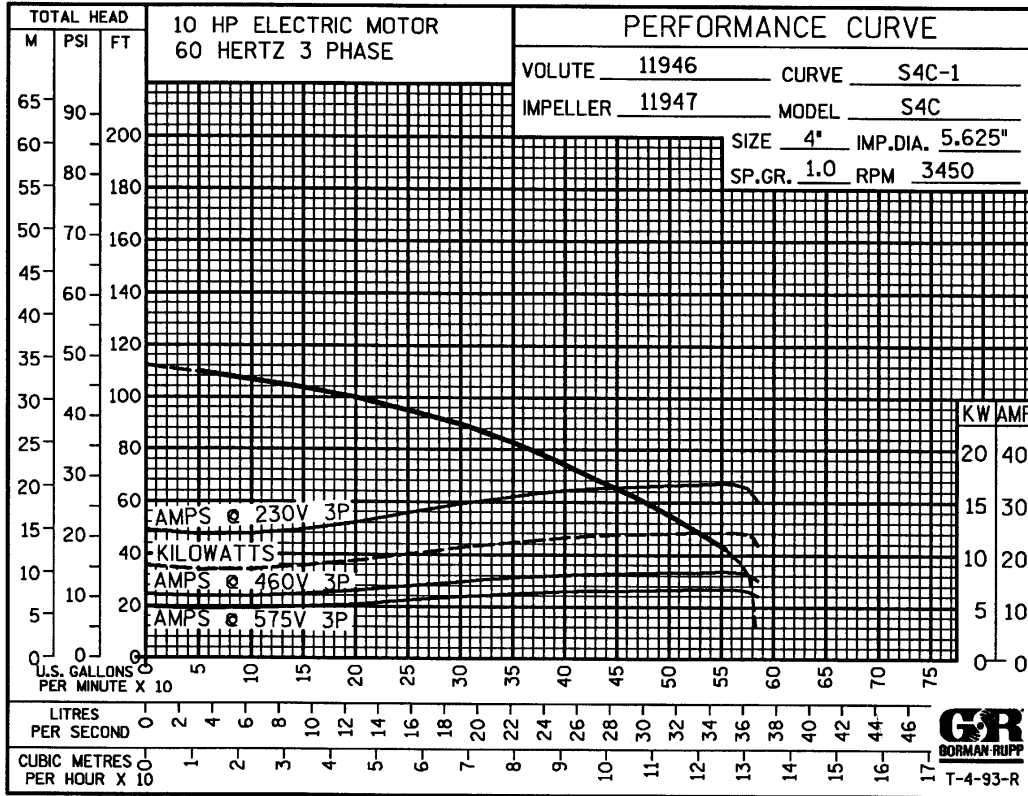

\* STANDARD PERFORMANCE FOR PUMP MODEL S4C1 230V 3P

\* Based on 70° F (21 ° C) clear water at sea level. Since pump installations are seldom identical, your performance may be different due to such factors as viscosity, specific gravity, elevation, temperature, and impeller trim.

If your pump serial number is followed by an "N", your pump is NOT a standard production model. Contact the Gorman-Rupp Company to verify performance or part numbers.

### CAUTION

Pump speed and operating condition points must be within the continuous performance range shown on the curve.

SECTION DRAWING

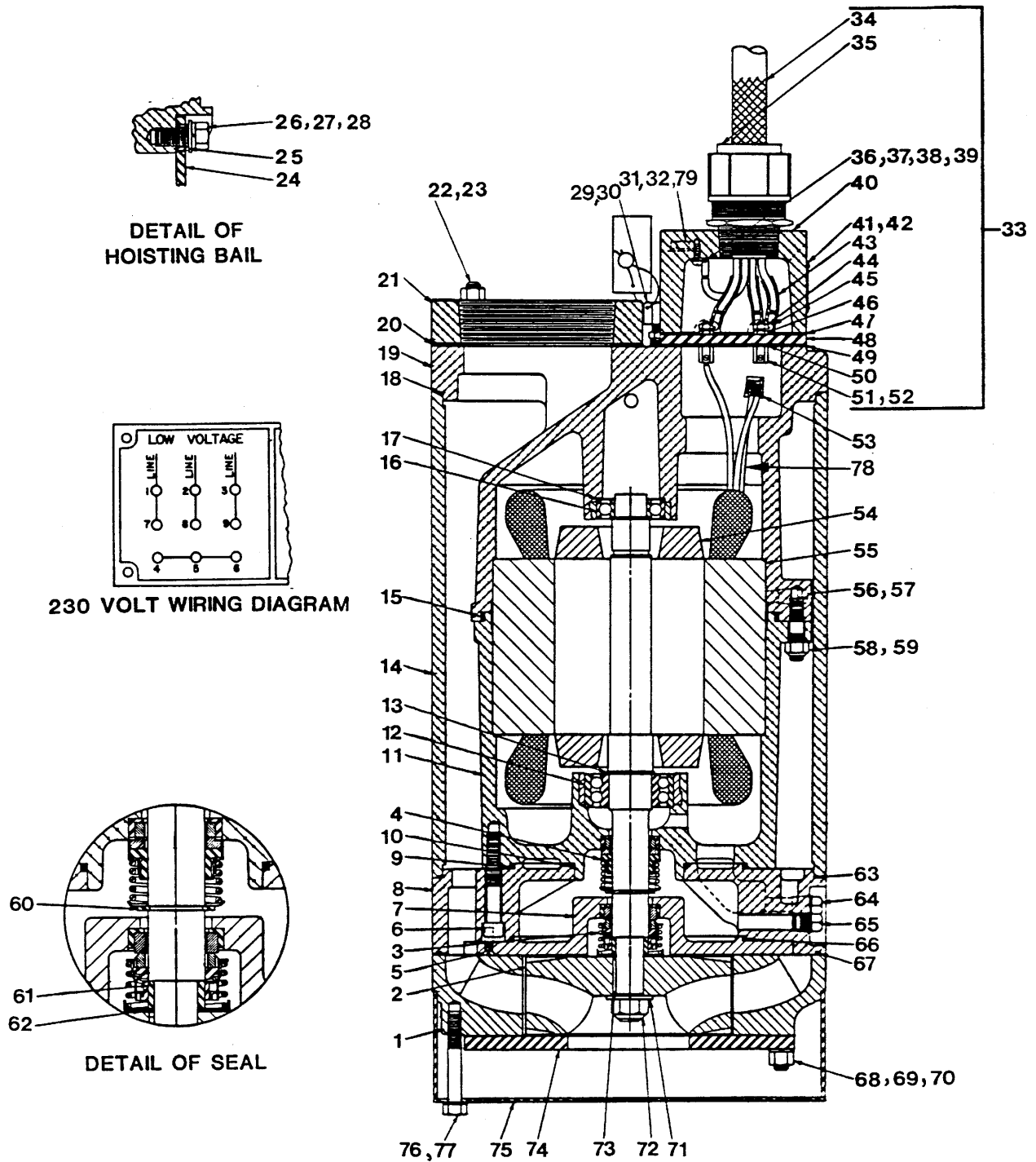

Figure 1. Pump Model S4C1-230V 3P

**PARTS LIST**  
**Pump Model S4C1 230V 3P**  
 (From S/N 860785 up)

If your pump serial number is followed by an "N", your pump is NOT a standard production model. Contact the Gorman-Rupp Company to verify part numbers.

ITEM NO.	PART NAME	PART NUMBER	MAT'L CODE	QTY	ITEM NO.	PART NAME	PART NUMBER	MAT'L CODE	QTY
1	DIFFUSER	11946	11010	1	55	STATOR ASSY	47113-853	-----	1
2 *	IMPELLER	11947	11010	1	56	PIPE PLUG	38649-022	17030	2
3 *	LWR SEAL ASSY	46512-057	-----	1	57	ALLEN HD SETSCRW	GA0501 1/4	15990	2
4 *	UPR SEAL ASSY	S1832	-----	1	58	STUD	C0606	17000	8
5	FLAT HD MACH SCRW	Y#10-03	17000	3	59	DEFORM LOCKNUT	DD06	17000	8
6	SOC HD CAPSCREW	DM0609	17000	3	60 *	SEAL RET RING	S362	-----	1
7	SEAL PLATE	13882	11030	1	61	SHAFT SLEEVE	13878	17020	1
8	INTERMEDIATE	13883	13040	1	62 *	ADJ SHIM SET	2-Y	17090	1
9 *	INTERMEDIATE GSKT	13928	20000	1	63 *	INTERM O-RING	S1830	-----	1
10	INTERMEDIATE GSKT	13929	20000	1	64	MOTOR CAVITY	P04	17000	1
11	LWR MOTOR HSG	11943-B	13040	1		DRAIN PLUG			
12 *	LWR BALL BEARING	23425-007	-----	1	65	SEAL CAVITY	P04	17000	1
13	BRG SNAP RING	S1831	-----	1		DRAIN/FILL PLUG			
14	PUMP CASING	11982	13175	1	66 *	SEAL PLATE GSKT	13928	20000	1
15 *	MTR HOUSING GSKT	11941-G	20000	1	67 *	DIFFUSER O-RING	S1830	-----	1
16 *	UPPER BALL BRG	S1044	-----	1	68	STUD	C0616	17000	3
17	BRG SPRING WASHR	S1554	-----	1	69	HEX NUT	D06	17000	3
18 *	PMP CASING O-RING	S1830	-----	1	70	LOCKWASHER	J06	17000	3
19 *	UPPER MTR HSG	38311-030	13040	1	71	FLAT WASHER	KB10	17000	1
20 *	DISCH FLANGE GSKT	11957-G	20000	1	72	IMPELLER NUT	D10-S	17000	1
21	DISCH FLANGE	11957	13040	1	73 *	IMPELLER KEY	N0303 1/2	17000	1
22	DISCH FLANGE STUD	C0609	15991	4	74 *	WEAR PLATE	11948	15010	1
23	HEX NUT	D06	15991	4	75 *	STRAINER ASSY	11969	2400V	1
24	HOISTING BAIL	11959	2400V	1	76	HEX HD CAPSCREW	B0610	15991	3
25	BUSHING	9562	15991	2	77	LOCKWASHER	J06	15991	3
26	HEX HD CAPSCREW	B0804	15991	2	78	WIRE MARKER KIT	S02274	-----	1
27	LOCKWASHER	J08	15991	2	79	HEX NUT	D05	15991	4
28	FLAT WASHER	KE08	15991	2		NOT SHOWN:			
29 *	RELIEF VALVE ASSY	46431-608	-----	1		NAME PLATE	38814-055	17000	1
30	REDUCING BUSHING	AP0604	15991	1		DRIVE SCREW	BM#04-03	17000	4
31	STUD	C0513	15991	4		CABLE TIE	27111-212	-----	1
32	LOCK WASHER	J05	15991	4		230/3 CONTROL BX	27515-504	-----	1
33	TERMINAL HOUSING & CABLE ASSY	47367-062	-----	1		SUBMERSIBLE PUMP	9568	-----	1
34 *	-POWER CABLE ASSY	10325-T	-----	1		OIL - 1 QT			
35 *	-CABLE GRIP ASSY	27111-026	-----	1		MOTOR PLATE	10436	17000	1
36	-RD HD MACH SCRW	X#10-02	15991	1		HEATER PACK	27521-207	-----	1
37	-T-TYPE LOCKWSHR	AK#10	15991	1		MOTOR VLT TAG	6588-Z	-----	1
38	-GRND TERMINAL	27214-243	-----	1		OPTIONAL:			
39	-GRND CHK TERMNL	S1836	-----	1		460 CONTROL BOX	27515-503	-----	1
40	-TERMINAL HSG	38381-230	13040	1		REPAIR GSKT KIT	11000-AC	-----	1
41	-INFORMATION PLATE	38816-047	17990	1		SST SEAL PLATE	13882	1718H	1
42	-DRIVE SCREW	BM#04-03	17000	4		SST WEAR PLATE	11948	1718H	1
43 *	-HEAT SHRINK TUBE	31411-233	19530	3		SST DIFFUSER	11946	1718H	1
	-ADHES RESERVOIR	31133-124	-----	1-		SST IMPELLER	11947	1718H	1
44	-UPPER HEX NUT	D#10	14990	3		STAGING ADAPTR KIT	48272-006	-----	1
45	-LEAD TERMINAL	27214-243	-----	3		ASSEMBLY			
46	-LOWER HEX NUT	D#10	14990	3		HEAT SHRINK TUBE & ADHESIVE KIT	48315-006	-----	1
47 *	-TERM PLATE GSKT	38687-525	20000	1		TERM POTTING KIT	12442-B	-----	1
48	-TERMINAL PLATE	38713-008	23010	1		ANODE PLATE ASSY	42116-003	-----	1
49 *	-TERM PLATE GSKT	38687-525	20000	1		OVERLOAD HEATER FOR DUAL VOLTAGE:			
50 *	-DYNA-SEAL WASHR	S1590	-----	3		230V	11960-A	-----	3
51	-TERMINAL	11181	14100	3		460V	11960-B	-----	3
52	-NYLOCK MACH SCRW	XA#10-011/4S	14990	3		LIQUID LEVEL DEVICES:			
53	CONNECTOR	S1718	-----	1		DIAPHRAGM TYPE	GRP48-03 OR GRP48-06	-----	1
	HEAT SHRINK TUBE	31411-235	19450	1		FLOAT TYPE	27471-155	-----	1
54 *	ROTOR ASSY	47112-807	-----	1		LIQUID LEVEL CONTROL RELAY	27521-321	-----	1

\* INDICATES PARTS RECOMMENDED FOR STOCK  
 Above Serial Numbers Do Not Apply To Pumps Made In Canada.  
 CANADIAN SERIAL NO. .... AND UP

PUMP AND MOTOR DISASSEMBLY AND REASSEMBLY

The following maintenance and repair instructions are keyed to the sectional view (see Figure 1) and the accompanying parts list.

WARNING

```

////////////////////////////////////
//
// The electrical power to operate this pump is high enough //
// to cause injury or death. Make certain that the control //
// handle on the control box is in the OFF position and //
// locked, or that the power supply to the control box has //
// been otherwise cut off and locked out, before attempting //
// to open or service the pump assembly. Tag electrical //
// circuits to prevent accidental start-up. //
// //
////////////////////////////////////

```

Before attempting to service the pump or control, cut off the power supply to the control box and close any valves in the discharge line.

WARNING

```

////////////////////////////////////
//
// Do not attempt to lift the pump by the motor power cable //
// or the piping. Attach proper lifting equipment to the //
// lifting device fitted to the pump. If chains or cable //
// are wrapped around the pump to lift it, make certain //
// that they are positioned so as not to damage pump, and //
// so that the load will be balanced. //
// //
////////////////////////////////////

```

Use the hoisting bail to lift the pump from the wet well and move it to a location where the discharge line can be removed. It is not necessary to disconnect flexible discharge hose before removing the pump. If rigid discharge piping is used, disconnect the piping or the discharge flange (21) before attempting to remove the pump. To remove the discharge flange, disengage the nuts (23) and remove the flange and gasket (20) from the upper motor housing (19).

Select a suitable location, preferably indoors, to perform the degree of maintenance required. If the motor housing is to be opened, the work must be done in a clean, well-equipped shop. All maintenance functions must be performed by qualified personnel.

Check the chart in **TROUBLESHOOTING** to determine the nature of the pump problem. If the problem is mechanical in nature, such as worn pump parts, seal replacement, lubrication, etc., refer to **PUMP END DISASSEMBLY**. If the problem is electrical, complete disassembly of the pump may not be required. Refer to **Electrical Testing** and have a qualified electrician check out the control box, cable and terminal housing assembly. If the problem is determined to be in the motor, proceed with **PUMP END DISASSEMBLY** followed by **MOTOR DISASSEMBLY**.

All gaskets and most O-rings **must** be replaced if disturbed. A repair gasket kit is listed on the parts list as an option.

---

---

## PUMP END DISASSEMBLY

### Strainer Disassembly

To remove the strainer assembly (75), raise the pump slightly or lay it on its side and remove the hardware (76 and 77) securing the strainer to the diffuser (1). If the impeller is clogged, the debris can usually be removed without further disassembly.

### Draining Oil From Seal And Motor

After removing the strainer, the wear plate (74), diffuser (1) and impeller (2) may be serviced without draining the oil cavities. However, the oil should be drained before attempting to replace the shaft seals (3 and 4) or repair the motor.

#### CAUTION

Let the pump cool before removing the seal or motor cavity drain plug. Pressure built up within a hot pump could cause the oil to spray out when the plug is removed. Remove the plug slowly and permit pressure to vent to atmosphere.

Lay the pump on its side with the drain plugs (64 and 65) facing up and clean any dirt from around the plugs. Remove the seal cavity drain plug (65) and install a short 1/4-inch NPT nipple in the hole. Tip the pump up and drain the seal oil into a **clean** container. Inspect it for water, dirt or cloudy condition which could indicate lower seal failure or poor gasket seal.

If motor problems are suspected, remove the motor cavity drain plug (64) and use a short nipple to drain the oil into a **clean** container at this time. Inspect the oil for dark color which could indicate motor overheating, dirt or water contamination. The presence of dirt or water could indicate a breakdown in the waterproof integrity of the motor cavity, probably due to poor gaskets or seals.

### Positioning Pump For Disassembly

It is recommended that the pump be positioned upside-down during disassembly. To hold the pump in an inverted position, secure the discharge flange studs (22) to a bench or work stand, or rest the pump securely on blocks. Be careful not to damage the terminal housing (40), power cable (34), or pressure relief valve (29) while the pump is in this position. Use adequate equipment and personnel to safely handle the pump until it is secured.

If inverting the pump is not practical, lay the pump on its side and secure it.

---

---

### Impeller Disassembly

For access to the impeller (2), remove the hardware (69 and 70) securing the wear plate (74) and diffuser (1) to the intermediate (8). Pull the wear plate and diffuser off the studs. Remove and discard the O-ring (67).

Wedge a piece of wood between the vanes of the impeller (2) and the intermediate studs (68) to prevent shaft rotation. Remove the impeller nut (72) and washer (71).

Remove the piece of wood from between the vanes of the impeller. Pry the impeller off the shaft using two screwdrivers as shown in Figure 2. Use caution when removing the impeller; tension on the seal spring will be released. Retain the impeller key (73).

Remove the impeller adjusting shims (62); for ease of reassembly, tie and tag the shims.

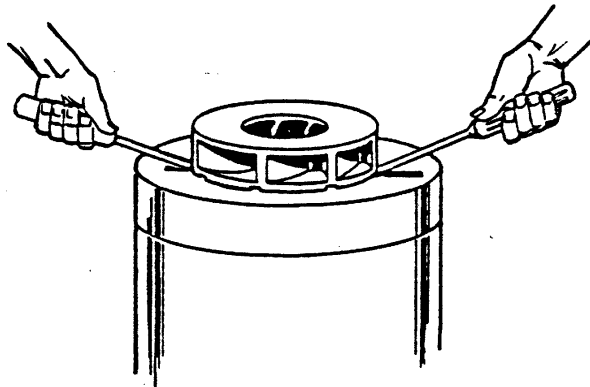

Figure 2. Removing Impeller

### Lower Seal Disassembly

#### (Figures 1 and 3)

Carefully remove the loose parts of the lower seal assembly (3). Use a stiff wire with a hooked end to pull the shaft sleeve (61) and rotating portion of the seal from the shaft. Lubricate the shaft sleeve adjacent to the seal, and work oil under the rubber bellows. Separate the sleeve from the rubber bellows.

To remove the stationary portion of the seal, remove the flat head machine screws (5) and separate the seal plate (7) from the intermediate (8). Remove and discard the seal plate gasket (66). Place the seal plate on a flat surface with the impeller side down. Use a drift pin or screw driver to press on alternate sides of the stationary seat until removed.

The rotating and stationary seal elements are precision finished and subject to wear. The complete seal should be replaced with each overhaul to ensure trouble-free operation. However, if the old seal must be reused, wrap the seal faces individually in tissue paper to prevent damage to the sealing surfaces.

---

---

If no further disassembly is required, proceed to the appropriate areas in **PUMP END REASSEMBLY**.

### Upper Seal Disassembly

#### (Figures 1 and 3)

Unless cracked or otherwise worn, it is not necessary to remove the intermediate (8) for access to the upper seal assembly (4). If intermediate removal is desired, remove the socket head capscrews (6) securing it to the lower motor housing (11). Remove and discard the intermediate gaskets (9 and 10) and O-ring (63).

Remove the seal retaining ring (60) with snap ring pliers. Use caution when removing the retaining ring; tension on the seal spring will be released. Remove the seal spring retainer and spring. Lubricate the rotor shaft adjacent to the seal, and work oil under the bellows. Use a stiff wire with a hooked end to pull the rotating portion of the seal off the shaft.

Slide the hooked ends of two wires along the shaft and under the stationary seal seat. Hook the back side of the seat and pull it from the intermediate.

#### NOTE

Do not disassemble the motor unless it is necessary and a clean, well-equipped shop is available. If the motor housing components are to be serviced, see **MOTOR DISASSEMBLY** in this section. Do not reassemble the pump end components at this time.

If no further disassembly is required, proceed to the appropriate areas in **PUMP END REASSEMBLY**.

### PUMP END REASSEMBLY

#### NOTE

Reuse of old O-rings, gaskets, or shaft seal parts may result in premature leakage or reduced pump performance. It is strongly recommended that an overhaul gasket kit and new shaft seal assemblies be used during reassembly (see the parts list for numbers).

### Cleaning Old Parts

With the pump inverted, stuff a clean tissue into the stationary seat bore of the lower motor housing (or wrap a small rag around the shaft) to prevent foreign material from entering the motor cavity.

MAINTENANCE AND REPAIR

Carefully inspect any O-rings or gaskets before removal and cleaning to determine if a proper seal and compression existed prior to disassembly. If sealing was faulty or questionable, the cause must be determined and corrected before reassembly. Replace any parts required.

Thoroughly clean all reuseable parts with a soft cloth soaked in cleaning solvent. Remove all O-rings and gaskets and clean the sealing surfaces of dirt or gasket material. Be careful not to scratch gasket surfaces.

WARNING

```

////////////////////////////////////
//
// Most cleaning solvents are toxic and flammable. Use //
// them only in a well-ventilated area free from excessive //
// heat, sparks, and flame. Read and follow all prec- //
// autions printed on solvent containers. //
//
////////////////////////////////////

```

Neither of the shaft seal assemblies should be reused because wear patterns on the finished faces cannot be realigned during reassembly. This could result in premature failure. If necessary to reuse an old seal in an emergency, **carefully** wash all metallic parts in fresh cleaning solvent and allow to dry thoroughly.

Handle the seal parts with extreme care to prevent damage. Be careful not to contaminate precision finished faces; even fingerprints on the faces can shorten seal life. If necessary, clean the faces with a non-oil based solvent and a clean, lint-free tissue. Wipe **lightly** in a concentric pattern to avoid scratching the faces.

Inspect the seal components for wear, scoring, grooves, and other damage that might cause leakage. If any components are worn, replace the complete seal; **never mix old and new seal parts.**

Install the shaft seals as illustrated in Figure 3.

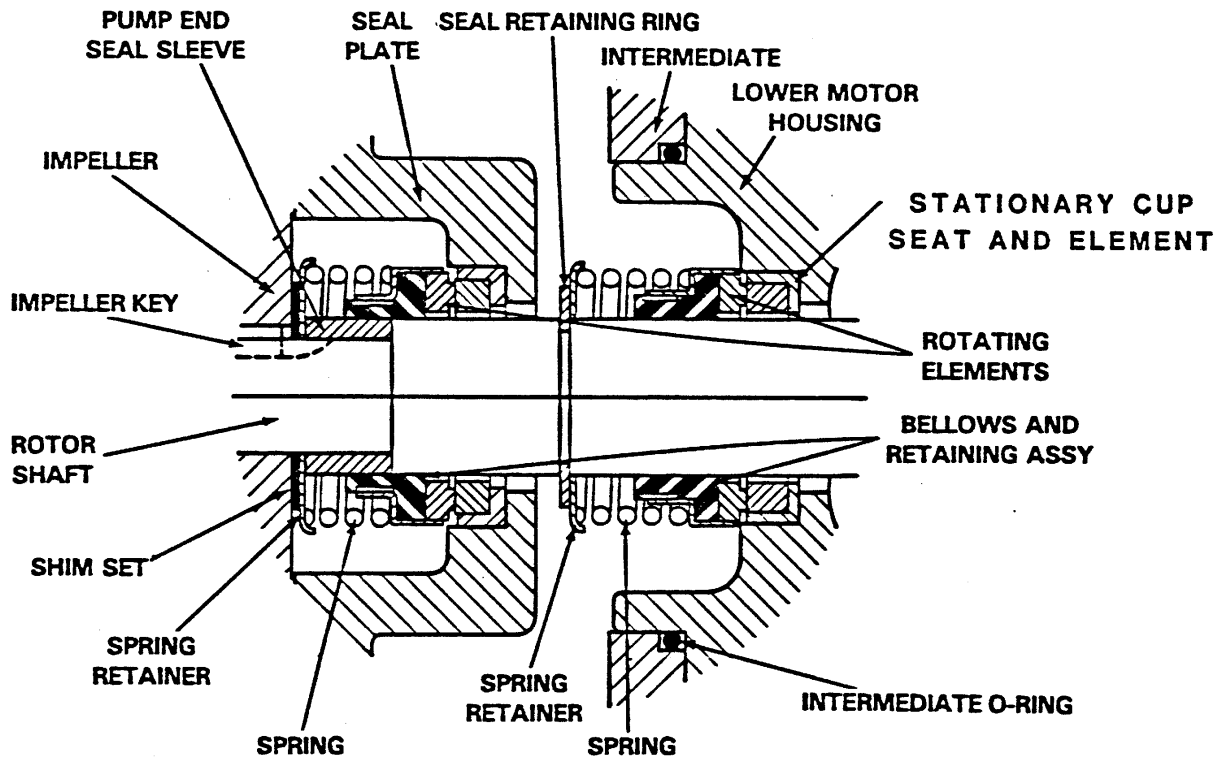

Figure 3. Seal Assemblies 46512-057 and S01832

### Upper Seal Reassembly

Inspect the end of the rotor shaft for damaged threads, scoring, and a nicked or damaged keyway. Remove nicks and burrs with a fine file or hand honing stone to restore original contours. If the shaft is bent or damaged, the complete shaft and rotor (54) must be replaced as an assembly (see **MOTOR DISASSEMBLY**).

If the intermediate (9) has been removed, replace the intermediate O-ring (63) and both intermediate gaskets (9 and 10), and position the intermediate on the lower motor housing (11). Coat the threads of the socket head capscrews (6) with 'Never-Seez' or equivalent compound, and install the capscrews through the intermediate and into the lower motor housing; torque the capscrews to 22 ft. lbs. (264 inch lbs.).

If a new seal is to be installed, do not unwrap it until time of installation. Cleanliness of all seal components is a must, especially the seal faces.

Carefully remove the material stuffed into the seat bore (or unwrap the shaft). Be sure no debris stopped by the material falls into the motor cavity.

Carefully clean the rotor shaft and seal bore in the intermediate (11). Check for burrs or nicks in the intermediate that might cut seal components or prevent a good seal. Apply a **light** coating of oil to the shaft and intermediate bore.

---

---

**NOTE**

When pressing seal components onto the impeller shaft, use hand pressure only. A push tube cut from a length of plastic pipe will aid in installing seal components. The I.D. of the push tube should be approximately the same as the I.D. of the seal spring.

Unpack the stationary seat and element. Subassemble the two parts and place a clean tissue over the seal face. Use your fingers to press the seat and element into the bore. Apply equal pressure on opposite sides of the seat until the assembly bottoms against the bore shoulder. Remove the tissue and inspect the seal face to ensure that it is clean and dry. If cleaning is necessary, use a clean tissue to wipe lightly in a concentric pattern.

Unpack the rotating portion of the seal. Be certain the seal face of the rotating element is free of grit or surface damage. Place a **small** amount of grease at equal spaces on the back of the element and assemble the drive grooves of the rotating element into the drive lugs of the bellows retainer. The grease should hold the element in position until the seal is installed.

Apply a light coating of oil to the seal seating surface on the shaft, the groove for the retaining ring (60), and the I.D. of the bellows. Position the rotating seal portion on the shaft with the seal face down. Apply firm, steady pressure, with clean hands, on the seal retainer until it slides down the shaft and the seal faces contact. This step should be done in one continuous motion to prevent the bellows from sticking or rolling as it passes over the retaining ring groove.

Slide the seal spring over the bellows retainer, and install the spring retainer. Install the seal retaining ring (60). See Figure 3 for proper order of seal assembly.

**Lower Seal Reassembly**

Thoroughly clean the gasket surfaces and seal bore of the seal plate (7). The seal bore must be free of burrs and nicks which could damage the seal.

**NOTE**

When pressing seal components into the seal plate and onto the impeller shaft, use hand pressure only. A push tube cut from a length of plastic pipe will aid in installing seal components. The I.D. of the push tube should be approximately the same as the I.D. of the seal spring.

Unpack the stationary seat and element and subassemble the two parts. Apply a light coating of oil to the seal plate bore and the outside of the seal seat. Place a clean tissue over the sealing face, and use your fingers to press the seat and element into the seal bore. Apply equal pressure on opposite sides of the seat until the assembly bottoms against the bore shoulder. Remove the tissue and inspect the seal face to ensure that it is clean and dry. If cleaning is necessary, use clean tissue to wipe lightly in a concentric pattern.

MAINTENANCE AND REPAIR

---

---

---

Replace the seal plate gasket (66). Carefully position the seal plate and stationary seal components on the rotor shaft and against the intermediate. **Be careful** not to damage the stationary seal element already installed. Secure the seal plate to the intermediate with the flat head machine screws (5).

Install the seal sleeve (61) with the chamfered end toward the shaft shoulder. Lubricate the O.D. with a light coating of oil.

Unpack the rotating portion of the seal. Be certain the seal face of the rotating element is free of grit or surface damage. Place a **small** amount of grease at equal spaces on the back of the element and assemble the drive grooves of the rotating element into the drive lugs of the bellows retainer. The grease should hold element in position until the seal is installed.

Apply a light coating of oil on the rotor shaft and I.D. of the bellows. Position the rotating seal portion on the shaft with the seal face down. Apply firm, steady pressure, with clean hands, on the seal retainer until it slides down the shaft and the seal faces contact.

Slide the seal spring over the bellows retainer, and install the spring retainer. See Figure 3 for proper order of seal assembly.

#### Impeller Reassembly

Inspect the impeller (2), and replace if cracked or badly worn. Clean the threads on the rotor shaft to remove any old thread locking material.

Install the same thickness of impeller adjusting shims (62) as originally removed. Install the impeller key (73) in the rotor shaft keyway, align the impeller keyway, and press the impeller onto the shaft until it seats firmly against the adjusting shims.

For maximum pump efficiency, there should be a clearance of .008 to .015 inch between the impeller and the wear plate. Position the wear plate against the diffuser and use a feeler gauge to measure this clearance. Add or remove impeller shims as required.

#### NOTE

The impeller and wear plate **must** be fully seated to obtain an accurate face clearance measurement.

After the impeller has been installed, coat the threads of the rotor shaft with 'Loctite Threadlocker No. 242' or equivalent compound. Install the impeller flat washer (71) and nut (72). Place a block of wood between the vanes of the impeller to prevent shaft rotation, and torque the impeller nut to 120 ft. lbs. (1440 inch lbs.).

#### Diffuser, Wear Plate And Screen Reassembly

Thoroughly clean the diffuser (1) and its O-ring surfaces. Replace the O-ring (67), and install it in the groove in the intermediate (8).

Inspect the wear plate (74). If one side is eroded, flip it over and install the smooth side next to the impeller. Replace the wear plate if both sides are badly scored or worn.

Carefully position the diffuser and wear plate over the studs (68) in the intermediate (8), and secure them with the hardware (69 and 70). After installing the diffuser and wear ring, check the impeller for free rotation.

Carefully position the strainer (75) on the diffuser (1), and secure it with the hardware (76 and 77). Make certain that the strainer seats properly against the shoulder of the diffuser.

**MOTOR DISASSEMBLY**

Disassembly of the motor is rarely required except to replace the motor rotor, stator, bearings, or intermediate. Do not disassemble the motor unless it is necessary and a clean, well-equipped shop is available.

**NOTE**

It is recommended that a pump with a defective motor be returned to Gorman-Rupp, or to one of the Gorman-Rupp authorized Submersible Repair Centers.

**WARNING**

////////////////////////////////////  
//  
// The electrical power to operate this pump is high enough //  
// to cause injury or death. Make certain that the control //  
// handle on the control box is in the OFF position and //  
// locked, or that the power supply to the control box has //  
// been otherwise cut off and locked out, before attempting //  
// to open or service the pump assembly. Tag electrical //  
// circuits to prevent accidental start-up. //  
// //  
////////////////////////////////////

Carefully inspect any O-rings or gaskets before removal and cleaning to determine if a proper seal and compression existed prior to disassembly. If sealing was faulty or questionable, the cause must be determined and corrected before reassembly. Replace any parts as required.

**Terminal Housing And Power Cable Disassembly**

If the pump is maintained in an upright position, the terminal housing and power cable assembly (33) may be serviced without draining the oil from the motor cavity. However, the oil must be drained before attempting to disassemble the motor housings (11 and 19) and components. To drain the oil, see **Draining Oil From Seal And Motor in PUMP END DISASSEMBLY.**

Total disassembly of the terminal housing and power cable is not always required. Disassemble and replace **only** the parts proven defective by inspection or testing. See **Electrical Testing in TROUBLESHOOTING.**

---

---

The terminal housing and power cable assembly (33) may be serviced without disassembling the motor housing or pump end. To remove the terminal housing, disengage the hardware (31 and 32) securing the terminal housing to the upper motor housing (19). Raise the terminal housing for access to the terminals (51). Loosen the nylock machine screws (52) and separate the motor leads from the terminals. Remove the lower terminal plate gasket (49).

To separate the power cable (34) from the terminal housing, unscrew the cable grip assembly (35) from the terminal housing. Compress the mesh on the cable grip and slide it up the power cable.

Push approximately 6 inches of the power cable into the terminal housing so that the terminal plate (48) comes free of the terminal housing. This should permit access to the power cable connections in the terminal housing.

To disconnect the power cable, remove the round head screws and lockwashers (36 and 37) securing the terminals (38 and 39) of the green and yellow ground leads. When shipped from the factory, the connections between the power cable leads and the terminals (51) were encapsulated in heat-shrink tubing (43) and bonded to the terminal plate with hot-melt adhesive. (In service, the adhesive may have been replaced by potting compound during previous repair.) Carefully cut away the adhesive (or potting) and remove the upper nuts (44). Disconnect the power cable leads from the terminals and remove the terminal plate and upper gasket (47).

#### NOTE

**Do not** remove the heat-shrink tubing from the power cable leads unless the terminals require replacement. If replacement is required, carefully cut the tubing from around the leads and terminals. The connection between the leads and terminals **must be** resealed with heat-shrink tubing before applying the hot-melt adhesive or potting (see **Terminal Housing And Power Cable Reassembly**).

After the terminal plate and upper gasket are removed, slide the terminal housing off the power cable. To remove the grip from the cable, compress the mesh and slide the grip down over the power cable leads.

If necessary to remove the terminals (51) from the terminal plate, disengage the lower nuts (46) and separate the terminals and dyna-seal washers (50) from the terminal plate.

See **Terminal Housing And Power Cable Reassembly** if no further disassembly is required.

#### Pump Casing And Motor Housing Disassembly

See **PUMP END DISASSEMBLY** and remove all pump end and seal components.

With the pump end disassembled and the motor cavity drained, secure the pump in an inverted position.

If the intermediate (8) was not removed at **Upper Seal Disassembly**, disengage the flat head machine screws (6) and remove the intermediate, gaskets (9 and 10) and O-ring (63) at this time. Slide the pump casing (14) off the upper motor housing (19) and remove the O-ring (18).

---

---

Remove the deformed locknuts (59), and separate the lower motor housing (11) from the upper motor housing (19). If necessary, pry the housings apart using two screwdrivers as shown in Figure 4. When the motor housings separate, remove the motor housing gasket (15).

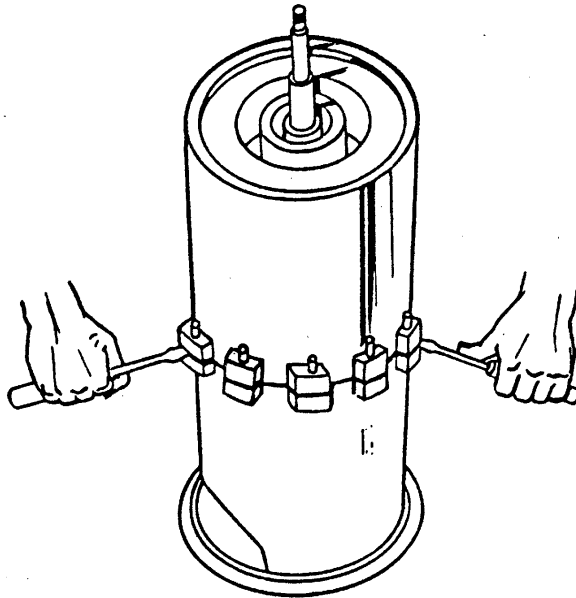

Figure 4. Separating Upper And Lower Motor Housings

#### Rotor Disassembly

Carefully pull the rotor (54) and the assembled ball bearings (12 and 16) from the stator. Handle the rotor carefully to prevent it from falling on the stator windings. With the rotor removed, reach into the upper housing and remove the wavy spring washer (17) from the bearing bore.

Use a bearing puller to remove the lower and upper ball bearings from the rotor shaft. It is not necessary to remove the snap ring (13) from the shaft unless replacement is required. Use snap ring pliers to remove the ring.

#### Stator Disassembly

It is recommended that the stator (55) be left in place unless it is defective. If the stator must be removed, disconnect the motor leads from the terminals (51) as indicated in **Terminal Housing And Power Cable Disassembly**.

Remove the pipe plugs (56) located in the upper motor housing, and loosen the allen head setscrews (57) located underneath the pipe plugs.

Position an expandable tool, such as a split disc, approximately 2 inches down inside the stator, and expand it tightly and squarely on the I.D. Attach a lifting device to the lifting eye of the tool and raise the assembly approximately one inch off the work surface. Take care not to damage the stator end turns.

---

---

Use a soft-faced mallet to rap alternate edges of the upper motor housing (19), and "walk" the stator out. Continue this process until the stator clears the motor housing.

#### NOTE

It may be necessary to heat the motor housing to permit stator removal.

After the stator has been removed, wrap it in clean dry rags or other suitable material. The stator **must** be kept clean and dry. When handling the stator, do not set it on the end windings; lay it on its side.

#### CAUTION

Do not attempt to rewind the stator. Winding tolerances and materials are closely controlled by the manufacturer, and any deviation can cause damage or operating problems. Replace the stator, or return it to one of The Gorman-Rupp Authorized Submersible Repair Centers or The Gorman-Rupp factory, if defective.

#### Relief Valve

It is recommended that the relief valve assembly (29) be replaced at each overhaul, or at any time the pump motor overheats and activates the valve. Never replace this valve with a substitute which has not been specified or provided by the Gorman-Rupp Company.

#### NOTE

It is not necessary to remove the reducing pipe bushing (30) to remove the relief valve assembly. If the pipe bushing is removed, apply 'Loctite Retaining Compound No. 609' or equivalent to the male threads of the bushing only.

When installing the relief valve, use 'Loctite Pipe Sealant With Teflon No. 592' or equivalent compound on the threads.

#### Hoisting Bail

If the hoisting bail (24) requires replacement, remove the hardware (26, 27, and 28) securing the bail to the upper motor housing (19). Make certain that the bushing (25) is in place when installing the hoisting bail.

MOTOR REASSEMBLY

WARNING

```

////////////////////////////////////
//
// Refer to the wiring diagrams in INSTALLATION when recon- //
// necting motor and power cable leads. //
// //
////////////////////////////////////

```

NOTE

Reuse of old O-rings, gaskets, or shaft seal parts may result in premature leakage or reduced pump performance. It is strongly recommended that an overhaul gasket kit and new shaft seal assemblies be used during reassembly (see the parts list for numbers).

Stator Reassembly

Clean all gasket and O-ring surfaces completely, removing any old gasket and cement material. Inspect the sealing surfaces for burrs, nicks, and pits which could cause a poor seal, and replace defective parts as required.

Thoroughly clean the inside of the upper motor housing (19) with fresh solvent. The interior must be dry and free of dirt or lint.

WARNING

```

////////////////////////////////////
//
// Most cleaning solvents are toxic and flammable. Use //
// them only in a well-ventilated area free from excessive //
// heat, sparks, and flame. Read and follow all prec- //
// autions printed on solvent containers. //
// //
////////////////////////////////////

```

Do not unwrap the stator until the motor housing has been prepared for stator installation. The stator must be kept clean and dry. When handling the stator, do not set it on its end windings; lay it on its side.

Test the stator as indicated in **Electrical Testing** in TROUBLESHOOTING to ensure that no damage has occurred during handling.

Position an expandable tool, such as a split disc, approximately 2 inches down inside the stator, and expand the tool tightly and squarely on the I.D. Attach a lifting device to the lifting eye of the tool and carefully lift the assembly. Take care not to damage the stator end turns. Slip a sleeve over the stator lead wires to prevent damage to them.

With the upper motor housing in an inverted position, position the stator so that the leads are in line with the opening for the terminal housing, and carefully lower the stator into the motor housing. If the stator "cocks" in the mo-

---



---

tor housing, remove it and try again. If necessary, heat the upper motor housing with a torch to expand it enough for the stator to be installed; when heating the motor housing, make certain that the stator is clear to avoid damage to the windings. Apply heat evenly to the inside of the motor housing; excessive heat is not required. Be careful not to damage the stator lead insulation during reassembly.

After the stator is fully and squarely seated on the upper motor housing shoulder, remove the expandable disc tool. Install the allen head setscrews (57) securing the stator in place; torque the setscrews to 7.5 ft. lbs. (90 inch lbs.). Coat the threads of the pipe plugs (56) with 'Loctite Pipe Sealant With Teflon No. 592' or equivalent, and install the plugs over the allen head setscrews.

Cover the motor housing with a clean, lint-free cloth while the rotor is being assembled.

### Rotor Reassembly

Inspect the seal and bearing areas of the shaft. Inspect the shaft for damaged threads, scoring and a nicked or damaged keyway. Remove nicks and burrs with a fine file or honing stone. If the shaft is bent or damaged, replace the shaft and rotor (a single assembly).

Clean the bearings thoroughly in **fresh** cleaning solvent. Dry the bearings with filtered compressed air and coat with light oil.

#### WARNING

```

////////////////////////////////////
//
// Most cleaning solvents are toxic and flammable. Use //
// them only in a well-ventilated area free from excessive //
// heat, sparks, and flame. Read and follow all prec- //
// autions printed on solvent containers. //
// //
////////////////////////////////////

```

Rotate the bearings by hand to check for roughness or binding and inspect the bearing balls. If rotation is rough or the bearing balls are discolored, replace the bearings.

#### CAUTION

Bearings must be kept free of all dirt and foreign material. Failure to do so will greatly shorten bearing life. DO NOT spin dry bearings. This may scratch the balls or races and cause premature bearing failure.

The bearing tolerances provide a tight press fit onto the shaft and a snug slip fit into the upper motor housing and intermediate. Replace the shaft and rotor (as an assembly), upper motor housing or intermediate if the proper bearing fit is not achieved.

If removed, install the lower bearing snap ring (13) on the rotor shaft. Position the lower ball bearing (12) on the shaft with the loading groove facing **toward** the impeller end of the shaft. Use an arbor (or hydraulic) press to install the bearing on the shaft until fully seated against the snap ring.

**CAUTION**

When installing the bearings onto the shaft, NEVER press or hit against the outer race, balls, or ball cage. Press ONLY on the inner race.

Press the upper ball bearing (16) onto the rotor shaft until fully seated against the shaft shoulder.

Clean the bore of the upper motor housing (19), and install the spring washer (17) in the bore.

Carefully lower the assembled rotor shaft and bearings through the stator until the upper ball bearing seats squarely in the upper motor housing bore.

**Motor Housing And Pump Casing Reassembly**

Use solvent to clean both bores and all gasket and O-rings surfaces of the lower motor housing (11), completely removing any old gasket and cement material. Inspect the sealing surfaces for burrs, nicks and pits which could cause a poor seal, and repair or replace as required.

**WARNING**

```

////////////////////////////////////
//
// Most cleaning solvents are toxic and flammable. Use //
// them only in a well-ventilated area free from excessive //
// heat, sparks, and flame. Read and follow all prec- //
// autions printed on solvent containers. //
// //
////////////////////////////////////
```

Replace the motor housing gasket (15). Position the lower motor housing (11) down over the stator, rotor shaft and assembled bearings so that it seats squarely against the upper motor housing (19). Be careful not to cut the motor housing gasket.

Coat the upper motor housing studs (58) with 'Never-Seez' or equivalent compound, and secure the upper and lower motor housings with the deformed locknuts (59); torque the locknuts to 20 ft. lbs. (240 inch lbs.).

Clean the sealing surfaces at each end of the pump casing (14), replace the O-ring (18), and slide the pump casing into position around the motor housings.

Install the gaskets (9 and 10) and O-ring (63) and position the intermediate (8) against the pump casing and lower motor housing. Be careful not to damage the gaskets or O-ring. Apply 'Never-Seez' or equivalent to the threads, and torque the socket head capscrews (6) to 22 ft. lbs. (264 inch lbs.).

See PUMP END REASSEMBLY, and reassemble the pump end components.

Terminal Housing And Power Cable Reassembly

WARNING

```

////////////////////////////////////
//
// The electrical power used to operate this pump is high //
// enough to cause injury or death. Make certain that the //
// control handle on the control box is in the OFF position //
// and locked, or that the power supply to the control box //
// has been otherwise cut off and locked out. Tag elec- //
// trical circuits to prevent accidental start-up. Obtain //
// the services of a qualified electrician and refer to the //
// wiring diagrams in INSTALLATION to make all electrical //
// connections. //
//
////////////////////////////////////

```

Clean the exterior of the pump power cable with warm water and mild detergent, and check for obvious physical damage. Check the cable for continuity and insulation resistance (see **Electrical Testing** in TROUBLESHOOTING).

CAUTION

<p>Do not attempt repairs except at either end of the power cable: Splicing is not recommended.</p>
---

Lubricate the bore of the cable grip (35) and the outside of the power cable (34). Compress the wire mesh on the cable grip and slide it onto the cable, allowing approximately 3 ft. of cable to extend beyond the cable grip.

Sealing Power Cable With Hot-Melt Adhesive

WARNING

```

////////////////////////////////////
//
// Do not attempt to operate this pump unless the power ca- //
// ble leads are sealed with heat-shrink tubing, and the //
// terminals and nuts (except the ground terminals) are //
// sealed with hot-melt adhesive or potting compound. //
// Moisture entering the terminal housing could cause a //
// short circuit, resulting in death or serious injury to //
// personnel. //
//
////////////////////////////////////

```

---

---

When shipped from the factory, the power cable leads and terminals were encapsulated in heat-shrink tubing (43) and bonded to the terminal plate (48) with hot-melt adhesive. If this insulating material has been damaged or removed during maintenance, it **must** be replaced using materials and heating equipment approved by Gorman-Rupp (see the parts list for repair kits).

#### NOTE

Heat-shrink tubing **must** be used to seal the power cable leads to the terminals; however, since a glue gun with the required temperature range is not generally available in the field, it is recommended that a repotting kit available from Gorman-Rupp (see the options listed on the parts list) or a commercially available kit (Products Research Corp., part no. PR-1201-Q Class 1 potting compound, or equivalent) be used to bond the connections to the terminal plate. If this alternate sealing method is used, refer to the instructions in **Sealing Power Cable With Potting Compound**.

If the power cable must be resealed, remove all the old adhesive (or potting compound) from the terminals (51), nuts (44 and 46) and terminal plate (48). Inspect the terminals and dyna-seal washers (50) for damage, and replace as required.

Slide the terminal housing (40) up the power cable (34) and temporarily secure it with the cable grip (35). Temporarily tape the ground leads (green and yellow) to the cable.

If the terminals (45) were removed from the leads, crimp a new terminal on each lead and slide a length of heat-shrink tubing (43) over each terminal. The tubing must cover the crimped part of the terminal and extend up the lead far enough to ensure a good seal. Carefully heat each tube with a torch or a commercial hot air gun capable of producing 750°F (399°C), and shrink them around the cable leads and terminals.

After the tubing has shrunk and set, position the upper terminal plate gasket (47) and the adhesive reservoir over the power cable leads. Secure the three power cable leads to the terminals (51) with the upper nuts (44). Slide the sealant reservoir down the cable and center it around the leads. Hold the terminal plate horizontally and apply the adhesive (G-R part number 18661-044) over the terminal posts with a hot-melt adhesive tool (Terlan model number TM-80), set at 450°F (232°C). The adhesive must cover the base of the heat-shrink tubes, **completely** filling the reservoir and insulating the electrical connections.

Unscrew the cable grip from the terminal housing and slide the housing down the cable. Untape the ground leads from the power cable. If removed, connect the two green ground leads to the ground terminal (38) and connect the yellow ground check lead to the ground check terminal (39). Secure the leads (green and yellow) to the terminal housing with the hardware (36 and 37); make sure the leads make a good ground with the housing.

Pull gently on the power cable (34) to remove any excess length from within the terminal housing. Apply 'Loctite Pipe Sealant With Teflon No. 592' or equivalent to the threads of the cable grip (35). Compress the wire mesh, and slide the grip down the cable, maintaining slight pressure to prevent excess slack, and screw it into the terminal housing until tight.

Position the lower terminal plate gasket (49) on the upper motor housing (19). Secure the motor leads to the terminals (51) with the nylock machine screws (52).

Position the terminal housing, terminal plate and gaskets against the upper motor housing. Apply 'Never-Seez' or equivalent compound to the capscrews (31), and secure the terminal housing to the upper motor housing with the capscrews and lockwashers (32); torque the capscrews to 20 ft. lbs. (240 inch lbs.).

See LUBRICATION and FINAL ASSEMBLY before putting the pump back into service.

### Sealing Power Cable With Potting Compound

Potting compound and hot-melt adhesive have the same electrical properties when correctly applied. Hot-melt adhesive is used at the factory to ease production. However, since a glue gun with the required temperature range is not generally available in the field, a potting kit is available from Gorman-Rupp (see the options listed on the parts list) for insulating the electrical connections. A commercially available repotting kit (Products Research Corp., part no. PR-1201-Q Class 1 potting compound, or equivalent) may also be used to reseal the connections. Refer to Figure 5 and the following instructions.

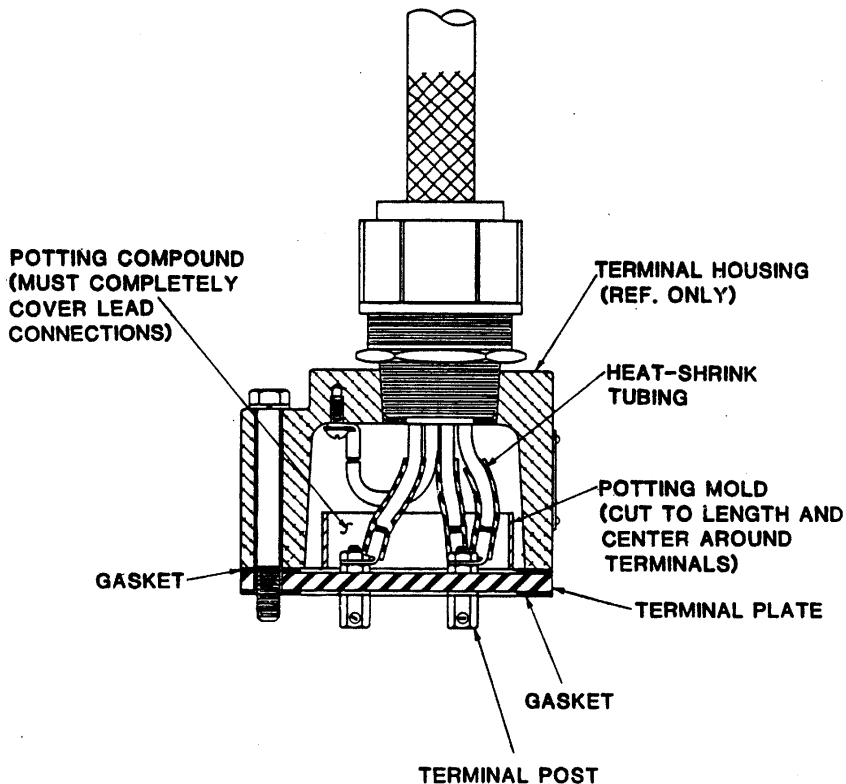

Figure 5. Potting Power Cable Leads In Terminal Housing

---



---

**WARNING**

```

////////////////////////////////////
//
// Do not attempt to operate this pump unless the power ca- //
// ble leads are sealed with heat-shrink tubing, and the //
// terminals and nuts (except the ground terminals) are //
// sealed with hot-melt adhesive or potting compound. //
// Moisture entering the terminal housing could cause a //
// short circuit, resulting in death or serious injury to //
// personnel. //
// //
////////////////////////////////////

```

Clean and assemble all terminal components as indicated in **Sealing Power Cable With Hot-Melt Adhesive**. Use medium grit sandpaper to prepare the surface of the terminal plate in the area where the potting mold will be installed.

**NOTE**

Clean the cable leads and terminal plate in the areas to be potted with cleaning solvent before potting. Potting compound will not adhere properly to oil or grease coated surfaces.

If the terminals (45) were removed from the leads, crimp a new terminal onto each lead and apply heat-shrink tubing as previously described.

Slide the terminal housing (40) up the power cable (34) and temporarily secure it with the cable grip (35). Temporarily tape the ground leads (green and yellow) to the cable.

Trim the potting mold as required so it is just long enough to cover the terminal post studs (see Figure 5). Slide the potting mold up over the three standard leads of the power cable.

Position the upper terminal plate gasket (47) over the power cable leads. Secure the three power leads to the terminals (51) with the upper nuts (44). Slide the potting mold down over the terminals and against the terminal plate. Hang the cable vertically, with the terminal plate horizontal. The cable leads and terminals should be centered in the potting mold. Use quick-setting cement, such as '3-M Weather Seal' to secure the potting mold to the terminal plate.

**WARNING**

```

////////////////////////////////////
//
// Most potting base compounds contain toluene; use ade- //
// quate ventilation and avoid prolonged breathing of va- //
// pors. Most potting accelerators contain lead; avoid //
// ingestion or prolonged contact with the skin. Read and //
// follow all warnings and recommendations accompanying the //
// potting kit. //
// //
////////////////////////////////////

```

See the instructions with the potting kit regarding application life, and setting and curing time. Mix the base compound and accelerator and fill the mold until the electrical connections are completely insulated. Tamp the potting ma-

terial to eliminate air bubbles and ensure the material has completely covered the area around the terminals.

When potting has been completed, leave the terminal plate assembly undisturbed until the potting material has cured. Complete curing usually takes about 24 hours. Curing time can be shortened by using a heat lamp, but be careful not to melt the potting or potting mold, or burn the cable. When the potting material is no longer "tacky" to the touch, it has cured.

When the potting material has cured, unscrew the cable grip from the terminal housing and slide the housing down the cable. Untape the ground leads from the power cable. If removed, connect the two green ground leads to the ground terminal (38) and connect the yellow ground check lead to the ground check terminal (39). Secure the leads (green and yellow) to the terminal housing with the hardware (36 and 37); make sure the leads make a good ground with the housing.

Pull the excess cable from the terminal housing and secure the cable grip and terminal plate as described in **Sealing Power Cable With Hot-Melt Adhesive**.

## LUBRICATION

Check the oil level in the seal cavity and motor housing before initial startup, after the first two weeks of operation, and every month thereafter. If the oil levels are abnormally low, or the color milky or dark, refer to **Draining Oil From Seal And Motor** in this section for instructions and troubleshooting tips.

### NOTE

To accurately check the oil level the pump must be cool.

The grade of lubricant used is critical to the operation of this pump. Use premium quality submersible pump oil of the grade specified in Table 1. Oil must be stored in a clean, tightly closed container in a reasonably dry environment.

Table 1. Typical Pump Oil Properties

Type .....	Premium high viscosity index, anti-wear hydraulic oil
Dielectric .....	26,000(volts-min)
Pour point .....	-20°F to -60°F
Viscosity @ 100°F .....	110 to 155
Viscosity @ 210°F .....	40 to 50
Recommended supplier:	
Gulf Oil Company .....	Gulf Harmony HVI AW 26
Acceptable alternate suppliers:	
Gulf Oil Company .....	Gulf Harmony 32 AW
SOHIO * .....	Energol - HLP 32
Shell Oil Company .....	Tellus 32, Tellus T-23 or T-32
Sun Oil Co. ....	Sunvis 816 or 916
Texaco .....	Rando HD 32 or HD AZ 32
A.R.CO. ....	Duro 32
Exxon .....	Nuto H 32

\* Also Boron & B.P. (British Petroleum) Oil Companies

---

---

### Seal Cavity

Lay the pump on its side, remove the seal cavity drain/fill plug (65) in the intermediate, and add approximately 1-1/4 pints of the recommended grade of submersible pump oil. Apply 'Loctite Pipe Sealant With Teflon No. 592', or equivalent sealant, to the threads of the drain/fill plug, and reinstall and tighten the plug.

### Motor Housing Cavity

With the pump in an upright position, remove the pressure relief valve (29) on top of the pump and add approximately 3 quarts of the recommended grade of submersible pump oil. Apply 'Loctite Pipe Sealant With Teflon No. 592', or equivalent sealant, to the threads of the pressure relief valve and reinstall the valve.

### FINAL ASSEMBLY

If the discharge flange (21) was separated from the upper motor housing, replace the gasket (20), and secure the flange with the nuts (23).

Connect the discharge hose, and position the pump in the wet well. If rigid discharge piping is used, connect the piping after the pump has been positioned. Open any valves in the discharge line.

**For U.S. and International Warranty Information,  
Please Visit [www.grpumps.com/warranty](http://www.grpumps.com/warranty)  
or call:  
U.S.: 419-755-1280  
International: +1-419-755-1352**

**For Canadian Warranty Information,  
Please Visit [www.grcanada.com/warranty](http://www.grcanada.com/warranty)  
or call:  
519-631-2870**