

# **60**SERIES

## **INSTALLATION, OPERATION, PARTS LIST, AND MAINTENANCE MANUAL**

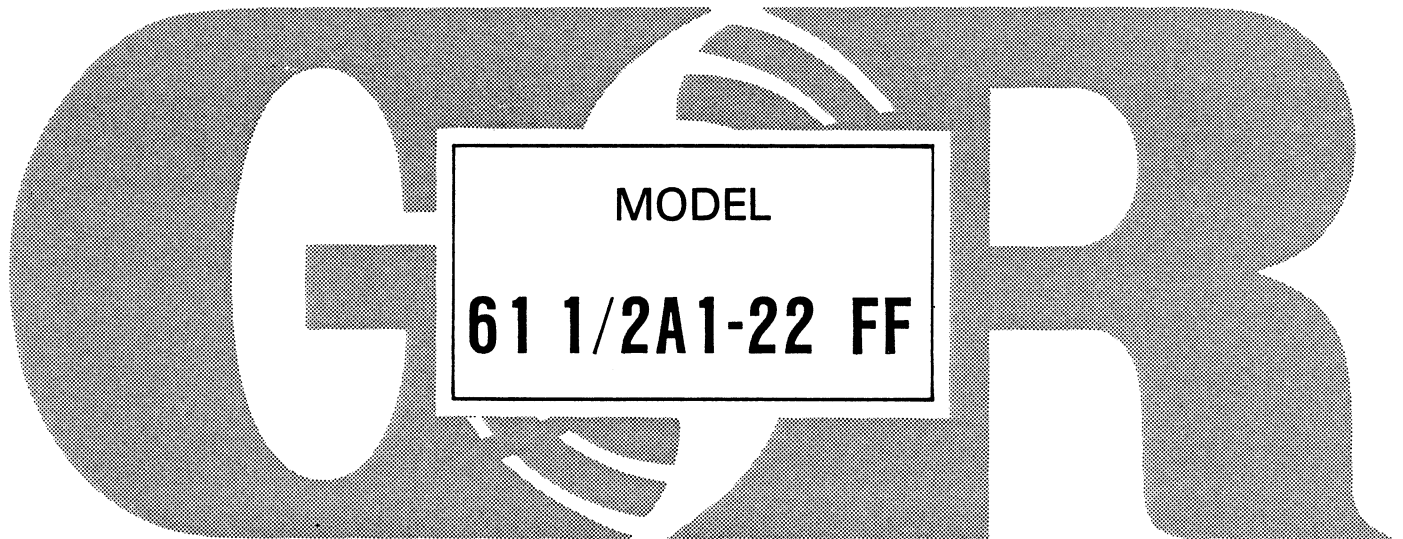

**THE GORMAN-RUPP COMPANY • MANSFIELD, OHIO**

GORMAN-RUPP OF CANADA LIMITED • ST. THOMAS, ONTARIO, CANADA

Printed in U.S.A.

© Copyright by the Gorman-Rupp Company 1985



# TABLE OF CONTENTS

INTRODUCTION . . . . .	I-1
WARNINGS - SECTION A . . . . .	A-1
INSTALLATION - SECTION B . . . . .	B-1
Pump Dimensions . . . . .	B-1
PREINSTALLATION INSPECTION . . . . .	B-2
POSITIONING PUMP . . . . .	B-2
Mounting . . . . .	B-2
SUCTION AND DISCHARGE PIPING . . . . .	B-3
Materials . . . . .	B-3
Line Configuration . . . . .	B-3
Connections to Pump . . . . .	B-3
Gauges . . . . .	B-3
SUCTION LINES . . . . .	B-4
Fittings . . . . .	B-4
Strainers . . . . .	B-4
Sealing . . . . .	B-4
Suction Lines In Sumps . . . . .	B-4
Suction Line Positioning . . . . .	B-5
DISCHARGE LINES . . . . .	B-6
Siphoning . . . . .	B-6
Valves . . . . .	B-6
OPERATION - SECTION C . . . . .	C-1
PRIMING . . . . .	C-1
Exhaust Primer . . . . .	C-1
STARTING . . . . .	C-2
OPERATION . . . . .	C-2
Leakage . . . . .	C-2
Liquid Temperature And Overheating . . . . .	C-2
Strainer Check . . . . .	C-3
Pump Vacuum Check . . . . .	C-3
STOPPING . . . . .	C-3
Cold Weather Preservation . . . . .	C-4
PUMP TROUBLESHOOTING - SECTION D . . . . .	D-1
PUMP MAINTENANCE AND REPAIR - SECTION E . . . . .	E-1
PERFORMANCE CURVE . . . . .	E-1
PUMP MODEL - PARTS LIST . . . . .	E-3
PUMP AND SEAL DISASSEMBLY AND REASSEMBLY . . . . .	E-4
Exhaust Primer Disassembly . . . . .	E-4
Pump Disassembly . . . . .	E-4
Seal Removal . . . . .	E-5
Seal Installation . . . . .	E-5
Pump Reassembly . . . . .	E-7
Exhaust Primer Reassembly . . . . .	E-8
LUBRICATION . . . . .	E-8
Seal Assembly . . . . .	E-8
Engine . . . . .	E-8



INTRODUCTION

This Installation, Operation, and Maintenance Manual is designed to help you achieve the best performance and longest life from your Gorman-Rupp pump.

This pump is a 60 Series, centrifugal model with an enclosed impeller. This pump is designed for use in fire fighting service. It is close-coupled to a Briggs and Stratton Model 221437 single cylinder, air cooled gasoline engine and mounted on a common hand-carry base. Standard equipment includes an exhaust primer system, spark arresting muffler, discharge check valve, suction strainer and discharge pressure gauge. The basic material of pump construction is aluminum, with cast iron wear ring, and a self-lubricated mechanical seal.

If there are any questions regarding the pump or its application which are not covered in this manual or in other literature accompanying this unit, please contact your Gorman-Rupp distributor, or write:

The Gorman-Rupp Company	or	Gorman-Rupp of Canada Limited
P.O. Box 1217		70 Burwell Road
Mansfield, Ohio 44901-1217		St. Thomas, Ontario N5P 3R7

For information or technical assistance on the engine, contact the engine manufacturer's local dealer or representative.

The following are used to alert maintenance personnel to procedures which require special attention, to those which could damage equipment, and to those which could be dangerous to personnel:

NOTE

Instructions to aid in installation, operation, and maintenance or which clarify a procedure.

CAUTION

Instructions which must be followed to avoid causing damage to the product or other equipment incidental to the installation. These instructions describe the requirements and the possible damage which could result from failure to follow the procedures.

WARNING

```

////////////////////////////////////
//                               //
// These instructions must be followed to avoid causing in- //
// jury or death to personnel, and describe the procedure //
// required and the injury which could result from failure //
// to follow the procedure. //
//                               //
////////////////////////////////////

```



WARNINGS

WARNINGS - SECTION A

THESE WARNINGS APPLY TO 60 SERIES ENGINE DRIVEN PUMPS. REFER TO THE MANUAL ACCOMPANYING THE ENGINE BEFORE ATTEMPTING TO BEGIN OPERATION.

WARNING

```

////////////////////////////////////
// Before attempting to open or service the pump: //
// //
// 1. Familiarize yourself with this manual. //
// 2. Disconnect the spark plug wire to ensure that the //
// pump will remain inoperative. //
// 3. Allow the pump to cool if overheated. //
// 4. Vent the pump slowly and cautiously. //
// 5. Close the suction and discharge valves. //
// 6. Check the temperature before opening any covers, //
// plates, or plugs. //
// 7. Drain the pump. //
// //
////////////////////////////////////

```

WARNING

```

////////////////////////////////////
// This pump is designed to handle clear water for high //
// pressure distribution. Do not attempt to pump volatile, //
// corrosive or flammable liquids which may damage the pump //
// or endanger personnel as a result of pump failure. //
// //
////////////////////////////////////

```

WARNING

```

////////////////////////////////////
// Do not operate the pump against a closed discharge valve //
// for long periods of time. This could bring the liquid //
// to a boil, build pressure, and cause the pump to rupture //
// or explode. //
// //
////////////////////////////////////

```

WARNING

```

////////////////////////////////////
// Do not remove plates, covers, gauges, pipe plugs, or //
// fittings from an overheated pump. Vapor pressure within //
// the pump can cause parts being disengaged to be ejected //
// with great force. Allow the pump to cool before servic- //
// ing. //
// //
////////////////////////////////////

```

WARNINGS

WARNING

```

////////////////////////////////////
//
// After the pump is installed, make certain the pump and //
// hoses are properly supported and secure before //
// operation. //
// //
////////////////////////////////////

```

WARNING

```

////////////////////////////////////
//
// Do not operate an internal combustion engine in an ex- //
// plosive atmosphere. When operating internal combustion //
// engines in an enclosed area, make certain that exhaust //
// fumes are piped to the outside. These fumes contain //
// carbon monoxide, a deadly gas that is colorless, //
// tasteless, and odorless. //
// //
////////////////////////////////////

```

WARNING

```

////////////////////////////////////
//
// Fuel used by internal combustion engines presents an ex- //
// treme explosion and fire hazard. Make certain that all //
// fuel lines are securely connected and free of leaks. //
// Never refuel a hot or running engine. Avoid overfilling //
// the fuel tank. Always use the correct type of fuel. //
// //
////////////////////////////////////

```

WARNING

```

////////////////////////////////////
//
// Never tamper with the governor to gain more power. The //
// governor establishes safe operating limits that should //
// not be exceeded. Continuous duty performance is limited //
// to 3600 RPM; however, the engine may be run at 3800 RPM //
// during intermittent fire fighting service. //
// //
////////////////////////////////////

```

INSTALLATION - SECTION B

Since pump installations are seldom identical, this section offers only general recommendations and practices required to inspect, position, and arrange the pump and piping.

Most of the information pertains to a standard **static lift application** where the pump is positioned above the free level of liquid to be pumped.

If installed in a **flooded suction application** where the liquid is supplied to the pump under pressure, some of the information such as mounting, line configuration, and priming must be tailored to the specific application. Since the pressure supplied to the pump is critical to performance and safety, **be sure** to limit the incoming pressure to 50% of the maximum permissible operating pressure as shown on the pump performance curve.

For further assistance, contact your Gorman-Rupp distributor or the Gorman-Rupp Company.

Pump Dimensions

See Figure 1 for the approximate physical dimensions of this pump.

OUTLINE DRAWING

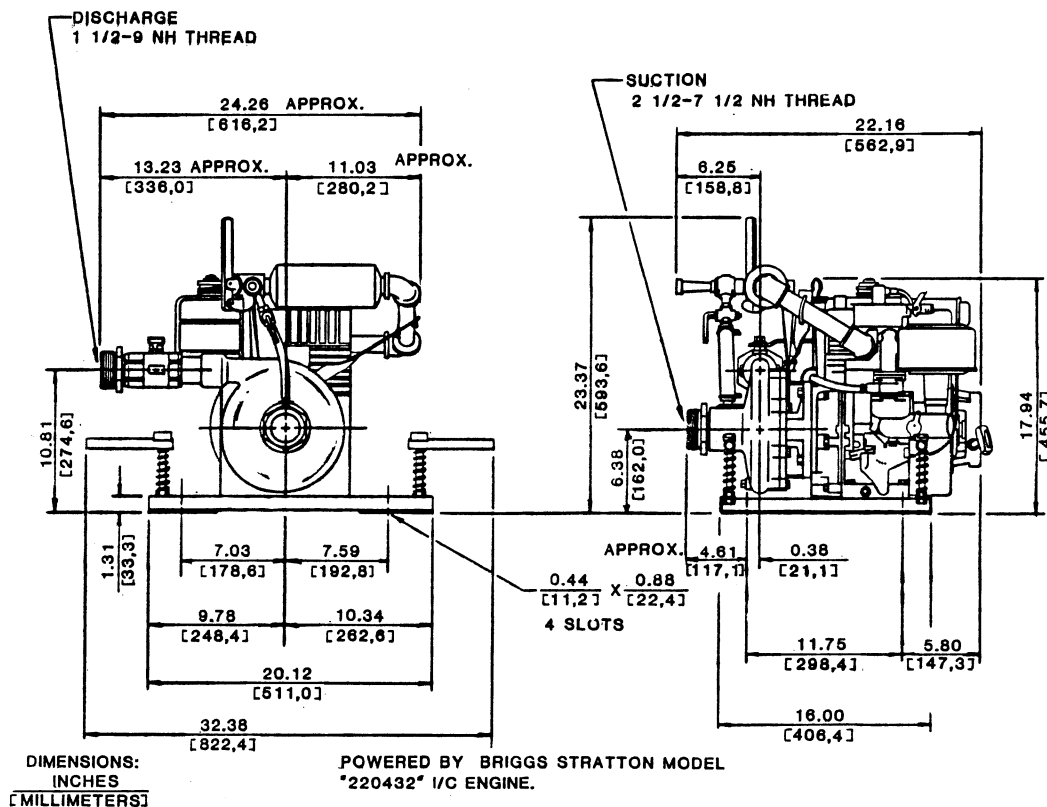

Figure 1. Pump Model 61 1/2A1-22 FF

---

---

## PREINSTALLATION INSPECTION

The pump assembly was inspected and tested before shipment from the factory. Before installation, inspect the pump for damage which may have occurred during shipment. Check as follows:

- a. Inspect the pump for cracks, dents, damaged threads, and other obvious damage.
- b. Check for and tighten loose attaching hardware. Since gaskets tend to shrink after drying, check for loose hardware at mating surfaces.
- c. Carefully read all tags, decals, and markings on the pump assembly, and follow the instructions indicated.
- d. Check all lubricant levels and lubricate as necessary. Refer to LUBRICATION in the MAINTENANCE AND REPAIR section of this manual and perform duties as instructed.
- e. If the pump and engine have been stored for more than 12 months, some of the components or lubricants may have exceeded their maximum shelf life. These **must be inspected or replaced** to ensure maximum pump service.
- f. Check to be sure the following standard equipment items are included, and properly installed on the pump:
  - Exhaust primer assembly.
  - Brass fire hose adaptors in pump suction and discharge ports.
  - Discharge pressure gauge.
  - Suction strainer assembly.

If the maximum shelf life on any item has been exceeded, or if anything appears to be abnormal, contact your Gorman-Rupp distributor or the factory to determine the repair or updating policy. **Do not** put the pump into service until appropriate action has been taken.

## POSITIONING PUMP

This pump is designed to be hand carried using the 2-man carry handles. The total pump weight is approximately 145 pounds, not including accessories or suction strainer. Customer installed equipment such as suction and discharge hoses **must** be removed before attempting to lift.

### Mounting

Locate the pump in an accessible place as close as practical to the liquid being pumped. Level mounting is essential for proper operation. The pump may have to be supported or shimmed to provide for level operation or to eliminate vibration.

---

---

To ensure sufficient lubrication and fuel supply to the engine, **do not** position the pump and engine more than 15° off horizontal for continuous operation. The pump and engine may be positioned up to 30° off horizontal for **intermittent operation only**; however, the engine manufacturer should be consulted for continuous operation at angles greater than 15°.

## SUCTION AND DISCHARGE PIPING

Pump performance is adversely effected by increased suction lift, discharge elevation, and friction losses. See the performance curve and recommendations on Page E-1 to be sure your overall application allows pump to operate within the safe operation range.

### Materials

Either pipe or hose may be used for suction and discharge lines; however, the materials must be compatible with the liquid being pumped. If hose is used in suction lines, it must be the rigid-wall, reinforced type to prevent collapse under suction. Using piping couplings in suction lines is not recommended.

### Line Configuration

Keep suction and discharge lines as straight as possible to minimize friction losses. Make minimum use of elbows and fittings, which substantially increase friction loss. If elbows are necessary, use the long-radius type to minimize friction loss.

### Connections to Pump

Before tightening a connecting flange, align it exactly with the pump port. Never pull a pipe line into place by tightening the flange bolts and/or couplings.

Lines near the pump must be independently supported to avoid strain on the pump which could cause excessive vibration, decreased bearing life, and increased shaft and seal wear. If hose-type lines are used, they should have adequate support to secure them when filled with liquid and under pressure.

### Gauges

Most pumps are drilled and tapped for installing discharge pressure and vacuum suction gauges. If these gauges are desired for pumps that are not tapped, drill and tap the suction and discharge lines not less than 18 inches from the suction and discharge ports and install the lines. Installation closer to the pump may result in erratic readings.

---

---

## SUCTION LINES

To avoid air pockets which could affect pump priming, the suction line must be as short and direct as possible. When operation involves a suction lift, the line must always slope upward to the pump from the source of the liquid being pumped; if the line slopes down to the pump at any point along the suction run, air pockets will be created.

### Fittings

Suction lines should be the same size as the pump inlet. If reducers are used in suction lines, they should be the eccentric type, and should be installed with the flat part of the reducers uppermost to avoid creating air pockets. Valves are not normally used in suction lines, but if a valve is used, install it with the stem horizontal to avoid air pockets.

### Strainers

If a strainer is furnished with the pump, be certain to use it; any spherical solids which pass through a strainer furnished with the pump will also pass through the pump itself.

If a strainer is not furnished with the pump, but is installed by the pump user, make certain that the total area of the openings in the strainer is at least three or four times the cross section of the suction line, and that the openings will not permit passage of solids larger than the solids handling capability of the pump.

This pump is designed to handle up to 7/32-inch diameter spherical solids.

It is recommended that a strainer with a built-in foot valve be installed in the suction line. The foot valve will hold water in the line while the pump is idle, eliminating the need to reprime.

### Sealing

Since even a slight leak will affect priming, head, and capacity, especially when operating with a high suction lift, all connections in the suction line should be sealed with pipe dope to ensure an airtight seal. Follow the sealant manufacturer's recommendations when selecting and applying the pipe dope. The pipe dope should be compatible with the liquid being pumped.

### Suction Lines In Sumps

If a single suction line is installed in a sump, it should be positioned away from the wall of the sump at a distance equal to one and one-half times the diameter of the suction line.

---

---

## INSTALLATION

---

---

If there is a liquid flow from an open pipe into the sump, the flow should be kept away from the suction inlet because the inflow will carry air down into the sump, and air entering the suction line will reduce pump efficiency.

If it is necessary to position inflow close to the suction inlet, install a baffle between the inflow and the suction inlet at a distance one and one-half times the diameter of the suction pipe. The baffle will allow entrained air to escape from the liquid before it is drawn into the suction inlet.

If two suction lines are installed in a single sump, the flow paths may interact, reducing the efficiency of one or both pumps. To avoid this, position the suction inlets so that they are separated by a distance equal to at least three times the diameter of the suction pipe.

### Suction Line Positioning

The depth of submergence of the suction line is critical to efficient pump operation. Figure 2 shows recommended minimum submergence vs. velocity.

#### NOTE

The pipe submergence required may be reduced by installing a standard pipe increaser fitting at the end of the suction line. The larger opening size will reduce the inlet velocity. Calculate the required submergence using the following formula based on the increased opening size (area or diameter).

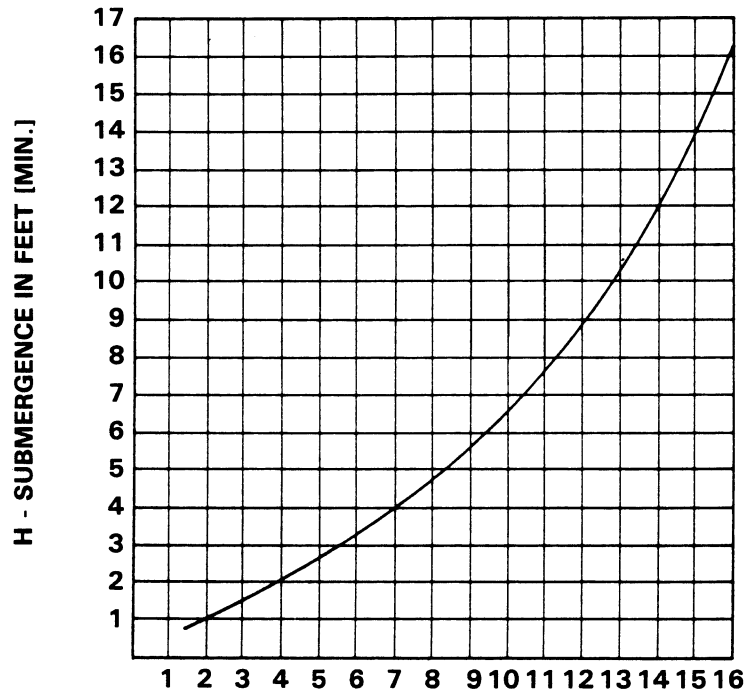

$$\text{VELOCITY IN FEET PER SEC.} = \frac{\text{QUAN. [G.P.M.] x .321}}{\text{AREA}} \text{ OR } \frac{\text{G.P.M. x .4085}}{D^2}$$

Figure 2. Recommended Minimum Suction Line Submergence Vs. Velocity

## DISCHARGE LINES

### Siphoning

Do not terminate the discharge line at a level lower than that of the liquid being pumped unless a siphon breaker is used in the line. Otherwise, a siphoning action causing damage to the pump could result.

### Valves

A check valve in the discharge line is normally recommended, but it is not necessary in low discharge head applications.

If a throttling valve is desired in the discharge line, use a valve as large as the largest pipe to minimize friction losses. Never install a throttling valve in a suction line.

With high discharge heads, it is recommended that a throttling valve and a system check valve be installed in the discharge line to protect the pump from excessive shock pressure and reverse rotation when it is stopped.

OPERATION - SECTION C

WARNING

```

////////////////////////////////////
//
// This pump is designed to handle clear water for high //
// pressure distribution. Do not attempt to pump volatile, //
// corrosive or flammable liquids which may damage the pump //
// or endanger personnel as a result of pump failure. //
//
////////////////////////////////////

```

WARNING

```

////////////////////////////////////
//
// Never tamper with the governor to gain more power. The //
// governor establishes safe operating limits that should //
// not be exceeded. Continuous duty performance is limited //
// to 3600 RPM; however; the engine may be run at 3800 RPM //
// during intermittent fire fighting service. //
//
////////////////////////////////////

```

PRIMING

Install the pump piping as described in INSTALLATION. Make sure that the piping connections are tight, and that the pump is securely mounted. Check that the pump is properly lubricated (see LUBRICATION in MAINTENANCE AND REPAIR).

Exhaust Primer

Since this pump is not self-priming, it is equipped with an exhaust primer assembly (Figure 1).

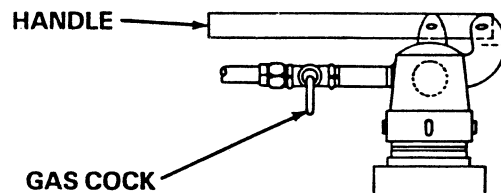

Figure 1. Exhaust Primer Assembly

---

---

The exhaust primer utilizes engine exhaust gases, directed through a venturi, to create a vacuum and draw air out of the suction line and pump casing.

The exhaust primer is capable of priming a pump with a maximum priming lift of 25 feet within 1 minute; less time will be required for priming at a lesser lift. If the pump does not prime in a reasonable length of time, check the suction line for leaks.

To prime the pump, close the throttling valve in the discharge line.

Close the exhaust primer handle (see Figure 1), and open the cock in the priming line. Consult the starting instructions in this manual as well as the engine operating manual, and start the engine. Operate the engine at maximum governed speed and allow the pump to prime until liquid flows continuously from the exhaust primer nozzle. When the pump is fully primed, open the exhaust primer handle, and close the cock in the priming line.

Once fully primed, reduce engine speed and partially open the discharge throttling valve. The discharge line should be filled slowly to prevent damage to the piping, gaskets, and other devices, resulting from the initial shock of liquid filling the lines. When the discharge line is completely filled, adjust the discharge throttling valve to the desired flow rate.

## STARTING

Consult the operations manual furnished with the engine.

## OPERATION

### Leakage

No leakage should be visible at pump mating surfaces, or at pump connections or fittings. Keep all line connections and fittings tight to maintain maximum pump efficiency.

### Liquid Temperature And Overheating

The **maximum** liquid temperature for this pump is 160°F. Do not apply it at a higher operating temperature.

Overheating can occur if operated with the valves in the suction or discharge lines closed. Operating against closed valves could bring the liquid to a boil, build pressure, and cause the pump to rupture or explode. If overheating occurs, stop the pump and allow it to cool before servicing it. Refill the pump casing with cool liquid.

WARNING

```

////////////////////////////////////
//
// Do not remove plates, covers, gauges, pipe plugs, or //
// fittings from an overheated pump. Vapor pressure within //
// the pump can cause parts being disengaged to be ejected //
// with great force. Allow the pump to cool before servic- //
// ing. //
// //
////////////////////////////////////

```

Strainer Check

If a suction strainer has been shipped with the pump or installed by the user, check the strainer regularly, and clean it as necessary. The strainer should also be checked if pump flow rate begins to drop. If a vacuum suction gauge has been installed, monitor and record the readings regularly to detect strainer blockage.

**Never** introduce air or steam pressure into the pump casing or piping to remove a blockage. This could result in personal injury or damage to the equipment. If backflushing is absolutely necessary, **liquid pressure** must be limited to 50% of the maximum permissible operating pressure shown on the pump performance curve.

Pump Vacuum Check

With the pump inoperative, install a vacuum gauge in the system, using pipe dope on the threads. Block the suction line and start the pump. At operating speed the pump should pull a vacuum of 20 inches or more of mercury. If it does not, check for air leaks in the seal, gasket, or discharge valve.

Open the suction line, and read the vacuum gauge with the pump primed and at operating speed. Shut off the pump. The vacuum gauge reading will immediately drop proportionate to static suction lift, and should then stabilize. If the vacuum reading falls off rapidly after stabilization, an air leak exists. Before checking for the source of the leak, check the point of installation of the vacuum gauge.

STOPPING

Never halt the flow of liquid suddenly. If the liquid being pumped is stopped abruptly, damaging shock waves can be transmitted to the pump and piping system. Close all connecting valves slowly. On engine driven pumps, reduce the throttle speed slowly and allow the engine to idle briefly before stopping.

---

---

---

**CAUTION**

If application involves a high discharge head, gradually close the discharge throttling valve before stopping the pump.

After stopping the pump, disconnect the spark plug wire to ensure that the pump will remain inoperative.

**Cold Weather Preservation**

In below freezing conditions, drain the pump to prevent damage from freezing. Also, clean out any solids by flushing with a hose. Operate the pump for approximately one minute; this will remove any remaining liquid that could freeze the pump rotating parts.

If the pump will be idle for more than a few hours, or if it has been pumping liquids containing a large amount of solids, drain the pump, and flush it thoroughly with clean water. To prevent large solids from clogging the drain port and preventing the pump from completely draining, insert a rod or stiff wire in the drain port, and agitate the liquid during the draining process. Clean out any remaining solids by flushing with a hose.

PUMP TROUBLESHOOTING - SECTION D

WARNING

```

////////////////////////////////////
//
// Before attempting to open or service the pump:
//
// 1. Familiarize yourself with this manual.
// 2. Disconnect the spark plug wire to ensure that the
//    pump will remain inoperative.
// 3. Allow the pump to cool if overheated.
// 4. Vent the pump slowly and cautiously.
// 5. Close the suction and discharge valves.
// 6. Check the temperature before opening any covers,
//    plates, or plugs.
// 7. Drain the pump.
//
////////////////////////////////////
    
```

TROUBLE	POSSIBLE CAUSE	PROBABLE REMEDY
PUMP FAILS TO PRIME	Auxiliary priming device faulty or improperly installed.	Repair priming device or check installation.
	Integral discharge check valve clogged or binding.	Clean valve.
	Air leak in suction line.	Correct leak.
	Lining of suction hose collapsed.	Replace suction hose.
	Leaking or worn seal or pump gasket.	Check pump vacuum. Replace leaking or worn seal or gasket.
	Suction lift or discharge head too high.	Check piping installation and install bypass line if needed. See INSTALLATION.
	Strainer clogged.	Check strainer and clean if necessary.
PUMP STOPS OR FAILS TO DELIVER RATED FLOW OR PRESSURE	Air leak in suction line.	Correct leak.
	Suction intake not submerged at proper level or sump too small.	Check installation and correct submergence as needed.
	Lining of suction hose collapsed.	Replace suction hose.

TROUBLE	POSSIBLE CAUSE	PROBABLE REMEDY
PUMP STOPS OR FAILS TO DELIVER RATED FLOW OR PRESSURE (cont.)	<p>Impeller or other wearing parts worn or damaged.</p> <p>Impeller clogged.</p> <p>Pump speed too slow.</p> <p>Suction lift too high.</p> <p>Leaking or worn seal or pump gasket.</p>	<p>Replace worn or damaged parts. Check that impeller is properly centered and rotates freely.</p> <p>Free impeller of debris.</p> <p>Check engine output; consult engine operation manual.</p> <p>Measure lift w/vacuum gauge. Reduce lift and/or friction losses in suction line.</p> <p>Check pump vacuum. Replace leaking or worn seal or gasket.</p>
PUMP REQUIRES TOO MUCH POWER	<p>Pump speed too high.</p> <p>Liquid solution too thick.</p> <p>Exceeding operating limits.</p>	<p>Check engine output.</p> <p>Dilute if possible.</p> <p>See performance curves in PUMP MAINTENANCE AND REPAIR.</p>
EXCESSIVE NOISE	<p>Cavitation in pump.</p> <p>Pumping entrained air.</p> <p>Pump or drive not securely mounted.</p> <p>Impeller clogged or damaged.</p>	<p>Reduce suction lift and/or friction losses in suction line. Record vacuum and pressure gauge readings and consult local representative or factory.</p> <p>Locate and eliminate source of air bubble.</p> <p>Secure mounting hardware.</p> <p>Clean out debris; replace damaged parts.</p>

PUMP MAINTENANCE AND REPAIR - SECTION E

MAINTENANCE AND REPAIR OF THE WEARING PARTS OF THE PUMP WILL MAINTAIN PEAK OPERATING PERFORMANCE.

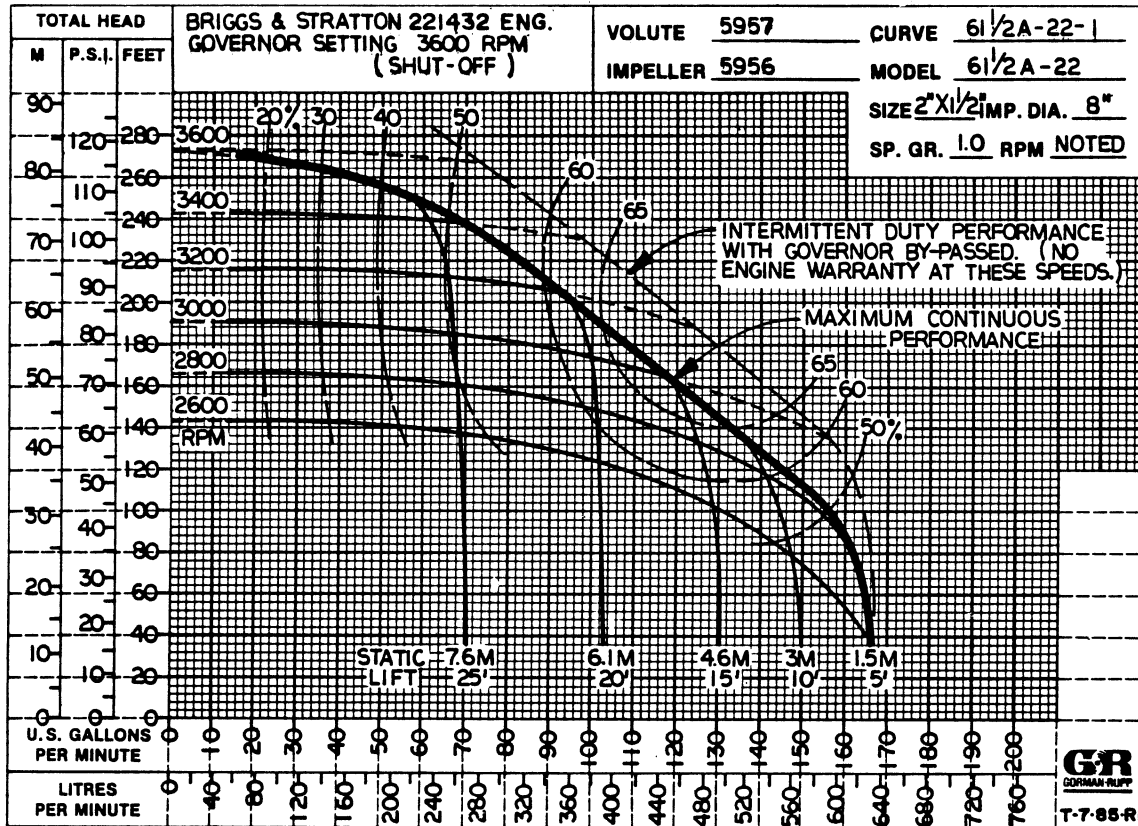

\*STANDARD PERFORMANCE FOR PUMP MODEL 61 1/2A1-22 FF

\*Based on 70°F clear water at sea level with minimum suction lift. Since pump installations are seldom identical, your performance may be different due to such factors as viscosity, specific gravity, elevation, temperature, and impeller trim.

If your pump serial number is followed by an "N", your pump is NOT a standard production model. Contact the Gorman-Rupp Company to verify performance or part numbers.

WARNING

```

////////////////////////////////////
//
// Never tamper with the governor to gain more power. The
// governor establishes safe operating limits that should
// not be exceeded. Continuous duty performance is limited
// to 3600 RPM; however, the engine may be run at 3800 RPM
// during intermittent fire fighting service.
//
////////////////////////////////////
    
```

SECTIONAL DRAWING

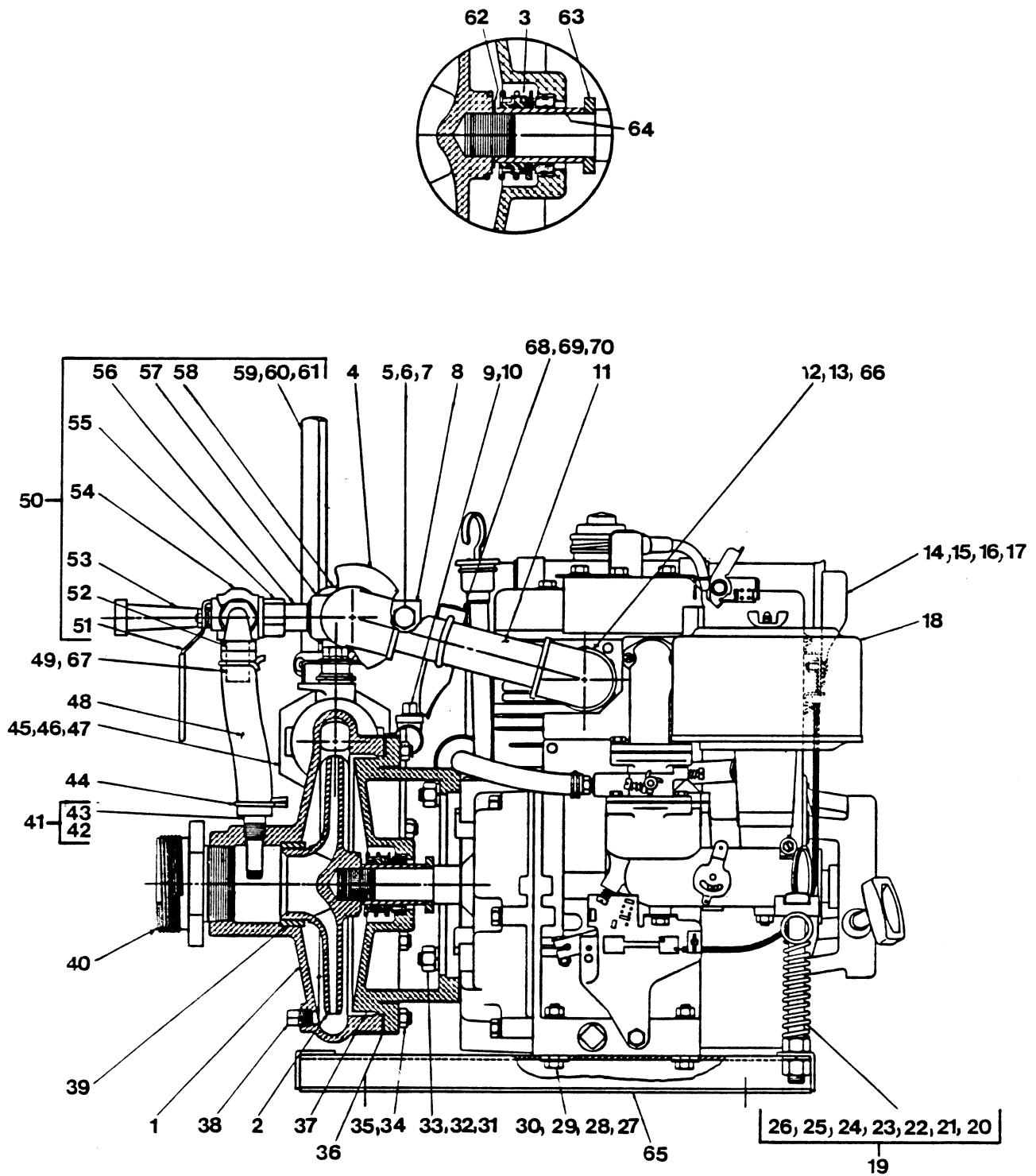

Figure 1. Pump Model 61 1/2A1-22 FF

**PARTS LIST**  
**PUMP MODEL 61 1/2A1-22 FF**  
 (From S/N 722770 up)

If your pump serial number is followed by an "N", your pump is **NOT** a standard production model. Contact the Gorman-Rupp Company to verify part numbers.

ITEM NO.	PART NAME	PART NUMBER	MATL CODE	QTY	ITEM NO.	PART NAME	PART NUMBER	MATL CODE	QTY
1	PUMP CASING	5957	13040	1	42	-NIPPLE	2434-A	15070	1
2	*IMPELLER	5956	13040	1	43	-NIPPLE	T0406	15070	1
3	*SEAL ASSY	S493	-----	1	44	HOSE CLAMP	S887	-----	2
4	MUFFLER	S337	-----	1	45	PIPE NIPPLE	T2412	15070	1
5	HEX HD CAPSCREW	B0604	15991	1	46	BALL VALVE	26631-028	-----	1
6	LOCKWASHER	J06	15991	1	47	NIPPLE	26525-624	-----	1
7	HEX NUT	D06	15991	1	48	PRIMING LINE	2435-K	19180	1
8	BRACKET	3647	15990	1	49	PIPE NIPPLE	2434	15070	2
9	STREET ELBOW	RS04	11990	2	50	EXH PRIMER ASSY	GRP15-04-A	-----	1
10	PIPE PLUG	P04	11990	1	51	-GAS COCK	S2	-----	1
11	PIPE NIPPLE	T1620	15070	1	52	-PIPE NIPPLE	T06	15070	1
12	PIPE ELBOW	R16	11990	2	53	-VENTURI	2345-A	14000	1
13	PIPE NIPPLE	T1612	15070	1	54	-EJECTOR BODY	3552	14000	1
14	THROTTLE CONTROL	29172-171	-----	1	55	-EJECTOR JET	3645-A	14000	1
15	SELF-TAPP SCREW	BP#10-01 1/2	15991	2	56	-PIPE NIPPLE	T0808	15070	1
16	LOCKWASHER	J#10	15991	2	57	-PRIMER VLV CAP	1469	10010	1
17	THROTTLE CABLE	44232-010	-----	1	58	-PRIMER VALVE	3643	10010	1
18	B & S ENGINE	29112-171	-----	1	59	-VALVE HANDLE	1458	15990	1
19	CARRY HANDLE ASSY	44724-002	-----	1	60	-SPRING WASHER	S165	-----	3
20	-SPRING	6077	16030	4	61	-COTTER PIN	M0406	15990	2
21	-HANDLE	6078	15070	4	62	*IMPELLER SHIM SET	2-X	17090	1
22	-POSITION LOCK	11680	12030	4	63	SEAL RING	2-A	15020	1
23	-MACHINE BOLT	A0818	15991	4	64	*SHAFT SLEEVE	2146	14000	1
24	-HEX NUT	D08	15991	4	65	BASE ASSY	41547-022	24000	1
25	-LOCKWASHER	AK08	15991	4	66	CONDUIT LOCK NUT	DF16	15990	1
26	-JAM NUT	AT08	15991	4	67	STREET ELBOW	RS06	11990	1
27	HEX HD CAPSCREW	B0507	15991	4	68	EXH PRIMER BRKT	34877-001	15990	1
28	FLAT WASHER	K05	15991	4	69	MUFFLER CLAMP	29334-254	-----	1
29	LOCK WASHER	J05	15991	4		-HEX NUT	D05	15991	2
30	HEX NUT	D05	15991	4	70	LOCKWASHER	J05	15991	2
31	STUD	C0608	15991	4	NOT SHOWN:				
32	LOCKWASHER	J06	15991	4		EXH PRIMER TAG	6588-X	00000	1
33	HEX NUT	D06	15991	4		EXH PRIMER DECAL	6588-AS	00000	1
34	STUD	C0605 1/2	15991	8		STRAINER	2184-A	-----	1
35	HEX NUT	D06	15991	8		*PRESSURE GAUGE	S180	-----	1
36	*CASING GSKT SET	2958-G	18000	1		PIPE PLUG	P06	11990	1
37	INTERMEDIATE	6701	13040	1		NAME PLATE	2613-ER	-----	1
38	PIPE PLUG	P04	11990	2		DRIVE SCREW	BM#04-03	-----	4
39	*WEAR RING	5978	10090	1	OPTIONAL:				
40	COUPLING	5968	14000	2		WHEEL KIT	GRP30-18	-----	1
41	SPECIAL NIPPLE	5769	-----	1					

\*INDICATES PARTS RECOMMENDED FOR STOCK

Above Serial Numbers Do Not Apply To Pumps Made In Canada.

CANADIAN SERIAL NO ..... AND UP

---



---

## PUMP AND SEAL DISASSEMBLY AND REASSEMBLY

This pump requires little service due to its rugged, minimum-maintenance design. However, if it becomes necessary to inspect or replace the wearing parts, follow these instructions which are keyed to the sectional view (see Figure 1) and the accompanying parts list.

Before attempting to service the pump, remove the suction and discharge hoses and disconnect the spark plug wire to ensure that the engine will remain inoperative.

For service information on the engine, consult the literature provided with the engine, or contact your local Briggs and Stratton engine representative.

### WARNING

```

////////////////////////////////////
//
// Before attempting to open or service the pump:
//
// 1. Familiarize yourself with this manual.
// 2. Disconnect the spark plug wire to ensure that the
//    pump will remain inoperative.
// 3. Allow the pump to cool if overheated.
// 4. Vent the pump slowly and cautiously.
// 5. Close the suction and discharge valves.
// 6. Check the temperature before opening any covers,
//    plates, or plugs.
// 7. Drain the pump.
//
////////////////////////////////////

```

### Exhaust Primer Disassembly

Loosen the hose clamps (44) and pull the rubber priming line (48) from the exhaust primer and pipe nipple assembly (41). If necessary, remove the gas cock valve (51) and pipe nipple assembly (41).

To separate the exhaust primer assembly (50) from the muffler, unscrew the ejector body (54) at the pipe nipple (56), and then unscrew the valve (58) from the muffler. To disassemble the exhaust primer, remove the valve handle, and unscrew the various primer components.

If no further pump disassembly is required, refer to **Exhaust Primer Reassembly**.

### Pump Disassembly

After disconnecting the rubber priming line, remove the drain plug (38) to drain the pump. Clean and reinstall the plug.

Remove the nuts (35) and separate the pump casing (1) from the intermediate (37). Carefully remove the casing gasket set (36) and clean the contacting surfaces.

Inspect the wear ring (39) for severe erosion or damage. The wear ring is retained by a press fit in the pump casing. To remove the ring, apply heat to the outside of the casing, or split the ring. **Be careful** not to damage the pump casing.

To remove the impeller, insert a steel bar or drift pin between the vanes, and turn it in a counter-clockwise direction (when facing the impeller) while holding the engine crankshaft stationary. **Be careful** not to damage the impeller vanes. Use caution when unscrewing the impeller; tension on the seal spring will be released as the impeller is removed.

Seal Removal

Remove the impeller adjusting shims (62). Tie and tag the shims or measure and record their thickness for ease of reassembly.

Remove the seal spring, then slide the shaft sleeve (64) and rotating portion of the seal off the engine shaft as a unit. Apply oil to the sleeve and work it up under the bellows. Slide the rotating portion of the seal off the sleeve.

Slide a stiff wire with a hooked end along the shaft and pull the stationary seat and O-ring from the intermediate bore.

NOTE

An alternate method of removing the stationary seat is to remove the hardware (32 and 33) and separate the intermediate (37) from the engine. Use a dowel to press the stationary seat and O-ring from the intermediate.

If the seal ring (63) requires replacement, remove the intermediate as described above and slide the seal ring off the shaft.

Seal Installation

(Figures 1 and 2)

Clean the seal cavity and shaft with a cloth soaked in fresh cleaning solvent.

WARNING

////////////////////////////////////  
//  
// Most cleaning solvents are toxic and flammable. Use //  
// them only in a well-ventilated area free from excessive //  
// heat, sparks, and flame. Read and follow all prec- //  
// autions printed on solvent containers. //  
// //  
////////////////////////////////////

The seal is not normally reused because wear patterns on the finished faces cannot be realigned during reassembly. This could result in premature failure. If necessary to reuse an old seal in an emergency, **carefully** wash all metallic parts in fresh cleaning solvent and allow to dry thoroughly.

Handle the seal parts with extreme care to prevent damage. Be careful not to contaminate precision finished faces; even fingerprints on the faces can shorten seal life. If necessary, clean the faces with a non-oil based solvent and a clean lint free tissue. Wipe **lightly** in a concentric pattern to avoid scratching the faces.

Inspect the seal components for wear, scoring, grooves, and other damage that might cause leakage. Clean and polish the shaft sleeve, or replace it if there are nicks or cuts on either end. If any components are worn, replace the complete seal; **never mix old and new seal parts.**

If a replacement seal is being used, remove it from the container and inspect the precision finished faces to ensure that they are free of any foreign matter.

To ease installation of the seal, lubricate the O-rings and shaft sleeve with water or a very **small** amount of oil, and apply a drop of light lubricating oil on the finished faces. Assemble the seal as follows, (see Figure 2).

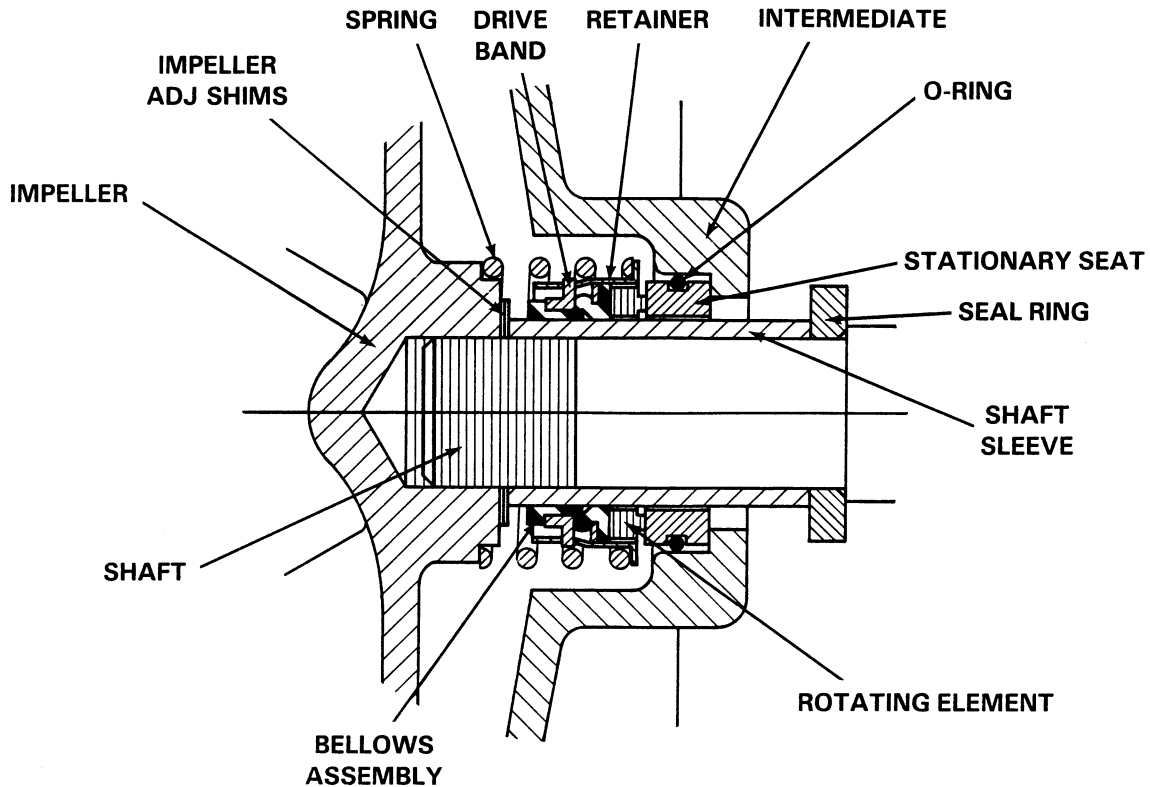

Figure 2. S493 Seal Assembly

#### CAUTION

This seal is not designed for operation at temperatures above 160°F. Do not use at higher operating temperatures.

If the intermediate was removed, lay it on a flat surface with the impeller side facing up. Subassemble the O-ring onto the stationary element and press this subassembly into the intermediate bore until it seats squarely against the shoulder. Install the seal ring (63), and secure the intermediate to the engine with the hardware (32 and 33). **Be careful** not to damage the stationary seat on the shaft threads.

Subassemble the rotating element into the retainer and bellows, then slide this subassembly onto the shaft sleeve until the face of the rotating element is **just flush** with the end of the sleeve. Slide the sleeve onto the shaft until the seal faces contact. Continue to push the sleeve through the seal until it seats against the seal ring.

Position the seal spring on the retainer, and proceed with **Pump Reassembly**.

### Pump Reassembly

If the wear ring (39) was removed, press the replacement ring into the casing bore until fully seated against the casing shoulder.

Inspect the impeller and replace it if cracked or badly eroded. Install the same thickness of impeller adjusting shims (62) as previously removed, and screw the impeller onto the shaft until tight.

For maximum pump efficiency, the impeller must be centered within the volute scroll of the pump casing. Use casing gaskets (36) and impeller shims to center the impeller as described below.

To verify the impeller positioning, measure the pump casing and impeller as shown in Figure 3. Use these measurements to calculate the required impeller location (dimension E). Add or remove impeller adjusting shims until dimension E is obtained.

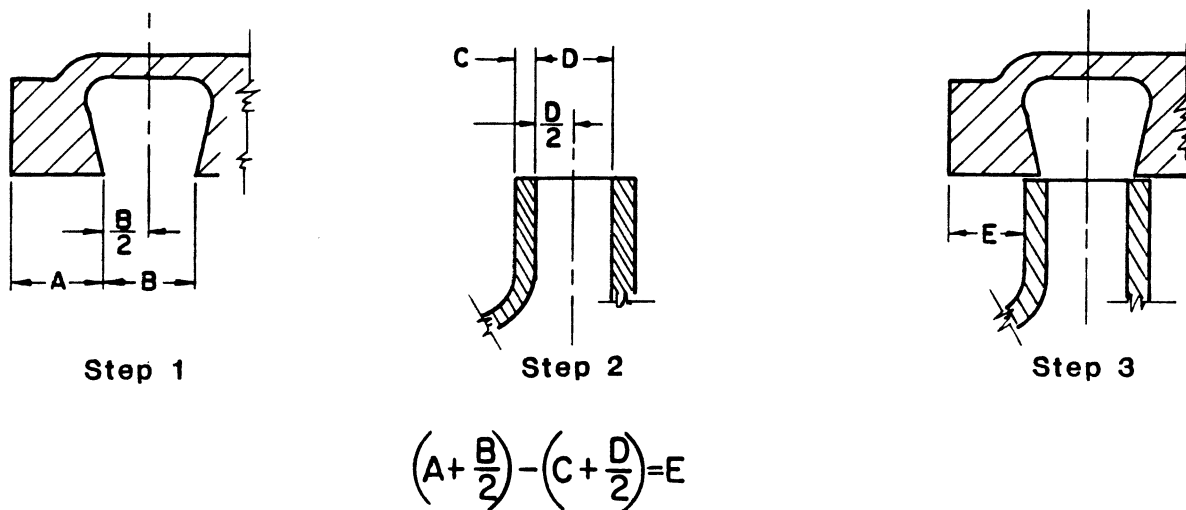

Figure 3. Centering Impeller Within Volute Scroll

---

---

### NOTE

After the impeller has been properly positioned, check for free rotation. Correct any scraping binding before further reassembly.

Install the casing gasket set (36). Carefully guide the wear ring into the eye of the impeller and secure the casing to the intermediate with the nuts (35).

### Exhaust Primer Reassembly

If the component parts for the exhaust primer assembly (50) were disassembled, clean or replace the parts as required, and screw them together as shown in Figure 1. If removed, install the gas cock valve (51) and pipe nipple assembly (41). Install the rubber priming line (48) between the exhaust primer and pipe nipple assembly (41), and it secure with the hose clamps (44).

### LUBRICATION

#### Seal Assembly

The shaft seal is lubricated by the liquid being pumped, and no additional lubrication is required.

#### Engine

Refer to the literature provided with the engine, or contact your local Briggs and Stratton engine representative.



**For U.S. and International Warranty Information,  
Please Visit [www.grpumps.com/warranty](http://www.grpumps.com/warranty)  
or call:  
U.S.: 419-755-1280  
International: +1-419-755-1352**

**For Canadian Warranty Information,  
Please Visit [www.grcanada.com/warranty](http://www.grcanada.com/warranty)  
or call:  
519-631-2870**