**INSTALLATION, OPERATION,
AND MAINTENANCE MANUAL**
WITH PARTS LIST



10 SERIES PUMPS

MODEL
14D2-F1L 210

THE GORMAN-RUPP COMPANY • MANSFIELD, OHIO
GORMAN-RUPP OF CANADA LIMITED • ST. THOMAS, ONTARIO, CANADA Printed in U.S.A.

©Copyright by the Gorman-Rupp Company

TABLE OF CONTENTS

INTRODUCTION	I-1
WARNINGS - SECTION A	A-1
INSTALLATION - SECTION B	B-1
Pump Dimensions	B-1
PREINSTALLATION INSPECTION	B-2
POSITIONING PUMP	B-2
Lifting	B-2
Mounting	B-2
Clearance	B-3
SUCTION AND DISCHARGE PIPING	B-3
Materials	B-3
Line Configuration	B-3
Connections to Pump	B-3
Gauges	B-4
SUCTION LINES	B-4
Fittings	B-4
Strainers	B-4
Sealing	B-4
Suction Lines In Sumps	B-5
Suction Line Positioning	B-5
DISCHARGE LINES	B-6
Siphoning	B-6
Valves	B-6
Bypass Lines	B-6
OPERATION - SECTION C	C-1
PRIMING	C-1
STARTING	C-2
OPERATION	C-3
Lines With a Bypass	C-3
Lines Without a Bypass	C-4
Leakage	C-4
Liquid Temperature And Overheating	C-4
Strainer Check	C-4
Pump Vacuum Check	C-5
STOPPING	C-5
Cold Weather Preservation	C-5
PUMP TROUBLESHOOTING - SECTION D	D-1
PUMP MAINTENANCE AND REPAIR - SECTION E	E-1
PERFORMANCE CURVE	E-1
PUMP MODEL - PARTS LIST	E-3
PUMP END ASSY - PARTS LIST	E-5
DRIVE ASSY - PARTS LIST	E-6
PUMP AND SEAL DISASSEMBLY AND REASSEMBLY	E-7
Suction Check Valve Removal	E-7
Back Cover Removal	E-8
Pump Casing Removal	E-8
Impeller Removal	E-8
Seal Removal	E-9
Stub Shaft Removal	E-9
Stub Shaft Installation	E-10
Seal Installation	E-10
Impeller Installation And Adjustment	E-12
Pump Casing Installation	E-12
Back Cover Installation	E-13
Suction Check Valve Installation	E-14
Final Pump Reassembly	E-14

LUBRICATION	E-14
Seal Assembly	E-14
Engine	E-15

INTRODUCTION

This Installation, Operation, and Maintenance Manual is designed to help you achieve the best performance and longest life from your Gorman-Rupp pump.

This pump is a 10 Series, semi-open impeller, self-priming centrifugal model with a suction check valve. The pump is designed to handle dirty water containing specified entrained solids. The basic material of construction for wetted parts is gray iron, with gray iron impeller and steel wearing parts. The pump is powered by an air-cooled Deutz Diesel engine, model F1L 210.

If there are any questions regarding the pump or its application which are not covered in this manual or in other literature accompanying this unit, please contact your Gorman-Rupp distributor, or write:

The Gorman-Rupp Company	or	Gorman-Rupp of Canada Limited
P.O. Box 1217		70 Burwell Road
Mansfield, Ohio 44901-1217		St. Thomas, Ontario N5P 3R7

For information or technical assistance on the engine, contact the engine manufacturer's local dealer or representative.

The following are used to alert maintenance personnel to procedures which require special attention, to those which could damage equipment, and to those which could be dangerous to personnel:

NOTE

Instructions to aid in installation, operation, and maintenance or which clarify a procedure.

CAUTION

Instructions which must be followed to avoid causing damage to the product or other equipment incidental to the installation. These instructions describe the requirements and the possible damage which could result from failure to follow the procedures.

WARNING

```

////////////////////////////////////
//
// These instructions must be followed to avoid causing in- //
// jury or death to personnel, and describe the procedure //
// required and the injury which could result from failure //
// to follow the procedure. //
// //
////////////////////////////////////

```

WARNINGS - SECTION A

THESE WARNINGS APPLY TO 10 SERIES ENGINE DRIVEN PUMPS. REFER TO THE MANUAL ACCOMPANYING THE ENGINE BEFORE ATTEMPTING TO BEGIN OPERATION.

WARNING

```

////////////////////////////////////
//
// Before attempting to open or service the pump:
//
// 1. Familiarize yourself with this manual.
// 2. Shut down the engine and take precautions to en-
//     sure that the pump will remain inoperative.
// 3. Allow the pump to cool if overheated.
// 4. Vent the pump slowly and cautiously.
// 5. Close the suction and discharge valves.
// 6. Check the temperature before opening any covers,
//     plates, or plugs.
// 7. Drain the pump.
//
////////////////////////////////////

```

WARNING

```

////////////////////////////////////
//
// This pump is designed to handle dirty water containing
// specified entrained solids. Do not attempt to pump vol-
// atile, corrosive or flammable liquids which may damage
// the pump or endanger personnel as a result of pump fail-
// ure.
//
////////////////////////////////////

```

WARNING

```

////////////////////////////////////
//
// After the pump has been installed, make certain that the
// pump and all piping connections are tight, properly sup-
// ported and secure before operation.
//
////////////////////////////////////

```

WARNING

```

////////////////////////////////////
//
// Do not operate the pump against a closed discharge valve
// for long periods of time. This could bring the liquid
// to a boil, build pressure, and cause the pump to rupture
// or explode.
//
////////////////////////////////////

```

WARNINGS

WARNING

```

////////////////////////////////////
//
// Overheated pumps can cause severe burns and injury. If //
// overheating of the pump occurs: //
//
// 1. Stop the pump immediately. //
// 2. Allow the pump to cool. //
// 3. Refer to instructions in this manual before re- //
// starting the pump. //
//
////////////////////////////////////

```

WARNING

```

////////////////////////////////////
//
// Do not remove plates, covers, gauges, pipe plugs, or //
// fittings from an overheated pump. Vapor pressure within //
// the pump can cause parts being disengaged to be ejected //
// with great force. Allow the pump to cool before servic- //
// ing. //
//
////////////////////////////////////

```

WARNING

```

////////////////////////////////////
//
// Fuel used by internal combustion engines presents an ex- //
// treme explosion and fire hazard. Make certain that all //
// fuel lines are securely connected and free of leaks. //
// Never refuel a hot or running engine. Avoid overfilling //
// the fuel tank. Always use the correct type of fuel. //
//
////////////////////////////////////

```

WARNING

```

////////////////////////////////////
//
// Do not operate an internal combustion engine in an ex- //
// plosive atmosphere. When operating internal combustion //
// engines in an enclosed area, make certain that exhaust //
// fumes are piped to the outside. These fumes contain //
// carbon monoxide, a deadly gas that is colorless, //
// tasteless, and odorless. //
//
////////////////////////////////////

```

INSTALLATION - SECTION B

Since pump installations are seldom identical, this section offers only general recommendations and practices required to inspect, position, and arrange the pump and piping.

Most of the information pertains to a standard **static lift application** where the pump is positioned above the free level of liquid to be pumped.

If installed in a **flooded suction application** where the liquid is supplied to the pump under pressure, some of the information such as mounting, line configuration, and priming must be tailored to the specific application. Since the pressure supplied to the pump is critical to performance and safety, **be sure** to limit the incoming pressure to 50% of the maximum permissible operating pressure as shown on the pump performance curve. (See Section E, Page 1). If the pump is fitted with a Gorman-Rupp double grease lubricated seal, the maximum incoming pressure must be reduced to 10 p.s.i..

For further assistance, contact your Gorman-Rupp distributor or the Gorman-Rupp Company.

Pump Dimensions

POWERED BY DELTZ DIESEL
ENGINE MODEL No. F1L 210

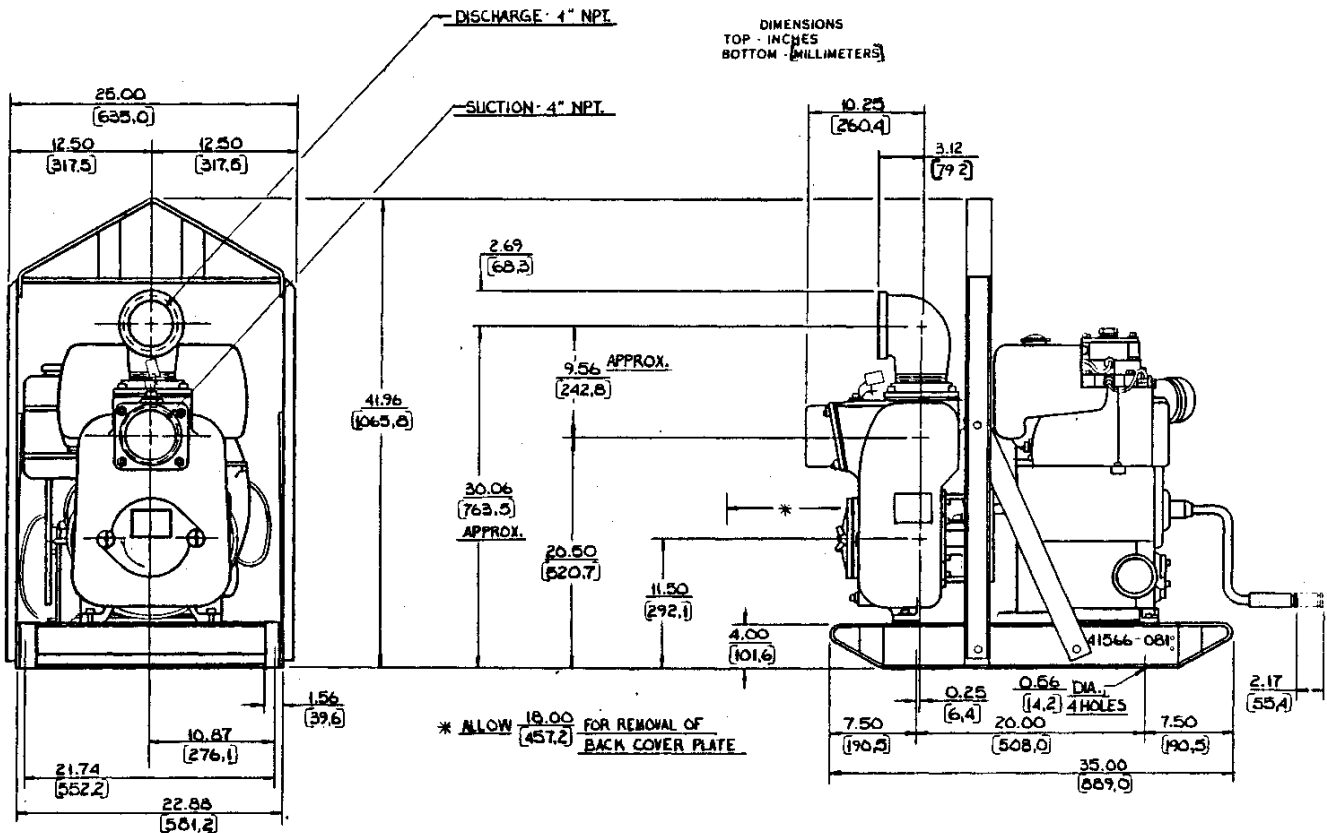

Figure 1. Pump Model 14D2-F1L 210

PREINSTALLATION INSPECTION

The pump assembly was inspected and tested before shipment from the factory. Before installation, inspect the pump for damage which may have occurred during shipment. Check as follows:

- a. Inspect the pump for cracks, dents, damaged threads, and other obvious damage.
- b. Check for and tighten loose attaching hardware. Since gaskets tend to shrink after drying, check for loose hardware at mating surfaces.
- c. Carefully read all tags, decals, and markings on the pump assembly, and follow the instructions indicated.
- d. Check all lubricant levels and lubricate as necessary. Refer to LUBRICATION in the MAINTENANCE AND REPAIR section of this manual and perform duties as instructed.
- e. If the pump and engine have been stored for more than 12 months, some of the components or lubricants may have exceeded their maximum shelf life. These **must be inspected or replaced** to ensure maximum pump service.

If the maximum shelf life has been exceeded, or if anything appears to be abnormal, contact your Gorman-Rupp distributor or the factory to determine the repair or updating policy. **Do not** put the pump into service until appropriate action has been taken.

POSITIONING PUMP

Lifting

Use lifting equipment with a capacity of at least **2,500 pounds**. This pump weighs approximately **485 pounds**, not including the weight of accessories and wheel kit. Customer installed equipment such as suction and discharge piping **must** be removed before attempting to lift.

CAUTION

The pump assembly can be seriously damaged if the cables or chains used to lift and move the unit are improperly wrapped around the pump.

Mounting

Locate the pump in an accessible place as close as practical to the liquid being pumped. Level mounting is essential for proper operation. The pump may have to

be supported or shimmed to provide for level operation or to eliminate vibration.

To ensure sufficient lubrication and fuel supply to the engine, **do not** position the pump and engine more than 15° off horizontal for continuous operation. The pump and engine may be positioned up to 30° off horizontal for **intermittent operation only**; however, the engine manufacturer should be consulted for continuous operation at angles greater than 15°.

If the pump has been mounted on a moveable base, make certain the base is stationary by setting the brake and blocking the wheels before attempting to operate the pump.

Clearance

When positioning the pump, allow a clearance of at least **18 inches** in front of the back cover assembly to permit removal of the back cover, and of the rotating assembly, which must be removed through the back of the pump.

SUCTION AND DISCHARGE PIPING

Materials

Either pipe or hose may be used for suction and discharge lines; however, the materials must be compatible with the liquid being pumped. If hose is used in suction lines, it must be the rigid-wall, reinforced type to prevent collapse under suction. Using piping couplings in suction lines is not recommended.

Line Configuration

Keep suction and discharge lines as straight as possible to minimize friction losses. Make minimum use of elbows and fittings, which substantially increase friction loss. If elbows are necessary, use the long-radius type to minimize friction loss.

Connections to Pump

Before tightening a connecting flange, align it exactly with the pump port. Never pull a pipe line into place by tightening the flange bolts and/or couplings.

Lines near the pump must be independently supported to avoid strain on the pump which could cause excessive vibration, decreased bearing life, and increased shaft and seal wear. If hose-type lines are used, they should have adequate support to secure them when filled with liquid and under pressure.

Gauges

Most pumps are drilled and tapped for installing discharge pressure and vacuum suction gauges. If these gauges are desired for pumps that are not tapped, drill and tap the suction and discharge lines not less than 18 inches from the suction and discharge ports and install the lines. Installation closer to the pump may result in erratic readings.

SUCTION LINES

To avoid air pockets which could affect pump priming, the suction line must be as short and direct as possible. When operation involves a suction lift, the line must always slope upward to the pump from the source of the liquid being pumped; if the line slopes down to the pump at any point along the suction run, air pockets will be created.

Fittings

Suction lines should be the same size as the pump inlet. If reducers are used in suction lines, they should be the eccentric type, and should be installed with the flat part of the reducers uppermost to avoid creating air pockets. Valves are not normally used in suction lines, but if a valve is used, install it with the stem horizontal to avoid air pockets.

Strainers

If a strainer is furnished with the pump, be certain to use it; any spherical solids which pass through a strainer furnished with the pump will also pass through the pump itself.

If a strainer is not furnished with the pump, but is installed by the pump user, make certain that the total area of the openings in the strainer is at least three or four times the cross section of the suction line, and that the openings will not permit passage of solids larger than the solids handling capability of the pump.

This pump is designed to handle up to 2 inch diameter spherical solids.

Sealing

Since even a slight leak will affect priming, head, and capacity, especially when operating with a high suction lift, all connections in the suction line should be sealed with pipe dope to ensure an airtight seal. Follow the sealant manufacturer's recommendations when selecting and applying the pipe dope. The pipe dope should be compatible with the liquid being pumped.

Suction Lines In Sumps

If a single suction line is installed in a sump, it should be positioned away from the wall of the sump at a distance equal to one and one-half times the diameter of the suction line.

If there is a liquid flow from an open pipe into the sump, the flow should be kept away from the suction inlet because the inflow will carry air down into the sump, and air entering the suction line will reduce pump efficiency.

If it is necessary to position inflow close to the suction inlet, install a baffle between the inflow and the suction inlet at a distance one and one-half times the diameter of the suction pipe. The baffle will allow entrained air to escape from the liquid before it is drawn into the suction inlet.

If two suction lines are installed in a single sump, the flow paths may interact, reducing the efficiency of one or both pumps. To avoid this, position the suction inlets so that they are separated by a distance equal to at least three times the diameter of the suction pipe.

Suction Line Positioning

The depth of submergence of the suction line is critical to efficient pump operation. Figure 2 shows recommended minimum submergence vs. velocity.

NOTE

The pipe submergence required may be reduced by installing a standard pipe increaser fitting at the end of the suction line. The larger opening size will reduce the inlet velocity. Calculate the required submergence using the following formula based on the increased opening size (area or diameter).

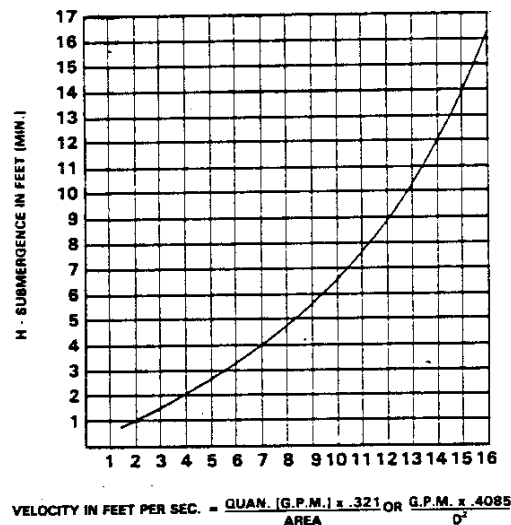

Figure 2. Recommended Minimum Suction Line Submergence Vs. Velocity

DISCHARGE LINES

Siphoning

Do not terminate the discharge line at a level lower than that of the liquid being pumped unless a siphon breaker is used in the line. Otherwise, a siphoning action causing damage to the pump could result.

Valves

A check valve in the discharge line is normally recommended, but it is not necessary in low discharge head applications.

If a throttling valve is desired in the discharge line, use a valve as large as the largest pipe to minimize friction losses. Never install a throttling valve in a suction line.

With high discharge heads, it is recommended that a throttling valve and a system check valve be installed in the discharge line to protect the pump from excessive shock pressure and reverse rotation when it is stopped.

CAUTION

If application involves a high discharge head, gradually close the discharge throttling valve before stopping the pump.

Bypass Lines

If it is necessary to permit the escape of air to atmosphere during initial priming or in the repriming cycle, install a bypass line between the pump and the discharge check valve. The bypass line should be sized so that it does not affect pump discharge capacity.

Either a Gorman-Rupp automatic air release valve - which will automatically open to allow the pump to prime, and automatically close when priming is accomplished - or a hand-operated shutoff valve should be installed in the bypass line.

NOTE

The bypass line may clog frequently, particularly if the valve remains closed. If this condition occurs, either use a larger bypass line or leave the shutoff valve open during the pumping operation.

Do not terminate the discharge line at a level lower than that of the liquid being pumped unless a siphon breaker is used in the line. Otherwise, a siphoning action could result, causing damage to the pump.

OPERATION - SECTION C

WARNING

```

////////////////////////////////////
//
// This pump is designed to handle dirty water containing //
// specified entrained solids. Do not attempt to pump vol- //
// atile, corrosive or flammable liquids which may damage //
// the pump or endanger personnel as a result of pump fail- //
// ure. //
// //
////////////////////////////////////

```

WARNING

```

////////////////////////////////////
//
// Never tamper with the governor to gain more power. The //
// governor establishes safe operating limits that should //
// not be exceeded. The maximum continuous operating speed //
// is 3000 RPM. //
// //
////////////////////////////////////

```

PRIMING

Install the pump and piping as described in **INSTALLATION**. Make sure that the piping connections are tight, and that the pump is securely mounted. Check that the pump is properly lubricated (see **LUBRICATION** in **MAINTENANCE AND REPAIR**).

This pump is self-priming, but the pump should never be operated unless there is liquid in the casing.

CAUTION

<p>Never operate a self-priming pump unless there is liquid in the casing. The pump will not prime when dry. Extended operation of a dry pump will destroy the seal assembly.</p>

Add liquid to the pump casing when:

1. The pump is being put into service for the first time.
2. The pump has not been used for a considerable length of time.
3. The liquid in the pump casing has evaporated.

Once the pump casing has been filled, the pump will prime as necessary.

OPERATION

WARNING

```

////////////////////////////////////
//
// After filling the pump casing, reinstall and tighten the //
// fill plug. Do not attempt to operate the pump unless //
// all connecting piping is securely installed. Otherwise, //
// liquid in the pump forced out under pressure could cause //
// injury to personnel. //
// //
////////////////////////////////////

```

To fill the pump, remove the pump casing fill cover or fill plug at the top of the casing and add clean liquid until the pump is filled. Replace the fill cover or fill plug before operating the pump.

NOTE

This pump is self-priming, however, it is **not** suited for unattended reprime applications. In the event of suction check valve failure and loss of prime, the pump casing **must** be refilled through the fill cover or fill plug.

STARTING

Consult the operations manual furnished with the engine.

WARNING

```

////////////////////////////////////
//
// Consult the operations manual furnished with the engine //
// before attempting to crank start the engine. When //
// starting, make sure footing is firm and dry and other //
// personnel are clear of the crank rotation plane. To //
// avoid kickback injury, keep legs and upper body out of //
// crank rotation plane and grasp the crank handle with THE //
// THUMB UNDER THE HANDLE (See Figure 1). //
// //
////////////////////////////////////

```

Since the engine can be started using a hand crank, be sure to follow all safety precautions to prevent possible injury due to engine kickback.

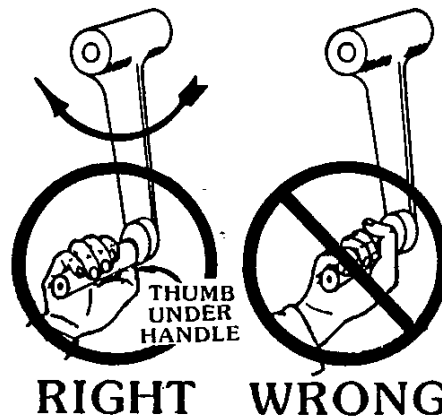

Figure 1. Crank Starting

OPERATION

CAUTION

Pump speed and operating condition points must be within the continuous performance range shown on the curve. See Section E, Page 1.

Lines With a Bypass

Either a Gorman-Rupp automatic air release valve or a hand operated shutoff valve may be installed in a bypass line.

If a Gorman-Rupp automatic air release valve has been installed, close the throttling valve in the discharge line. The Gorman-Rupp valve will automatically open to allow the pump to prime, and automatically close when priming has been accomplished. After the pump has been primed, and liquid is flowing steadily from the bypass line, open the discharge throttling valve.

If a hand operated shutoff valve has been installed, close the throttling valve in the discharge line, and open the bypass shutoff valve so that the pump will not have to prime against the weight of the liquid in the discharge line. When the pump has been primed, and liquid is flowing steadily from the bypass line, close the bypass shutoff valve and open the discharge throttling valve.

OPERATION

Lines Without a Bypass

Open all valves in the discharge line and start the power source. Priming is indicated by a positive reading on the discharge pressure gauge or by a quieter operation. The pump may not prime immediately because the suction line must first fill with liquid. If the pump fails to prime within five minutes, stop it and check the suction line for leaks.

After the pump has been primed, partially close the discharge line throttling valve in order to fill the line slowly and guard against excessive shock pressure which could damage pipe ends, gaskets, sprinkler heads, and any other fixtures connected to the line. When the discharge line is completely filled, adjust the throttling valve to the required flow rate.

Leakage

No leakage should be visible at pump mating surfaces, or at pump connections or fittings. Keep all line connections and fittings tight to maintain maximum pump efficiency.

Liquid Temperature And Overheating

The maximum liquid temperature for this pump is 110°F. Do not apply it at a higher operating temperature.

Overheating can occur if operated with the valves in the suction or discharge lines closed. Operating against closed valves could bring the liquid to a boil, build pressure, and cause the pump to rupture or explode. If overheating occurs, stop the pump and allow it to cool before servicing it. Refill the pump casing with cool liquid.

WARNING

////////////////////////////////////
//
// Do not remove plates, covers, gauges, pipe plugs, or //
// fittings from an overheated pump. Vapor pressure within //
// the pump can cause parts being disengaged to be ejected //
// with great force. Allow the pump to cool before servic- //
// ing. //
//
////////////////////////////////////

Strainer Check

If a suction strainer has been shipped with the pump or installed by the user, check the strainer regularly, and clean it as necessary. The strainer should also be checked if pump flow rate begins to drop. If a vacuum suction gauge has been installed, monitor and record the readings regularly to detect strainer blockage.

OPERATION

Never introduce air or steam pressure into the pump casing or piping to remove a blockage. This could result in personal injury or damage to the equipment. If backflushing is absolutely necessary, **liquid pressure** must be limited to 50% of the maximum permissible operating pressure shown on the pump performance curve. (See Section E, Page 1). If the pump is fitted with a Gorman-Rupp double grease lubricated seal, the maximum incoming pressure must be reduced to 10 p.s.i..

Pump Vacuum Check

With the pump inoperative, install a vacuum gauge in the system, using pipe dope on the threads. Block the suction line and start the pump. At operating speed the pump should pull a vacuum of 20 inches or more of mercury. If it does not, check for air leaks in the seal, gasket, or discharge valve.

Open the suction line, and read the vacuum gauge with the pump primed and at operating speed. Shut off the pump. The vacuum gauge reading will immediately drop proportionate to static suction lift, and should then stabilize. If the vacuum reading falls off rapidly after stabilization, an air leak exists. Before checking for the source of the leak, check the point of installation of the vacuum gauge.

STOPPING

Never halt the flow of liquid suddenly. If the liquid being pumped is stopped abruptly, damaging shock waves can be transmitted to the pump and piping system. Close all connecting valves slowly. On engine driven pumps, reduce the throttle speed slowly and allow the engine to idle briefly before stopping.

CAUTION

If application involves a high discharge head, gradually close the discharge throttling valve before stopping the pump.

After stopping the pump, shut down the engine and take precautions to ensure that the pump will remain inoperative.

Cold Weather Preservation

In below freezing conditions, drain the pump to prevent damage from freezing. Also, clean out any solids by flushing with a hose. Operate the pump for approximately one minute; this will remove any remaining liquid that could freeze the pump rotating parts.

If the pump will be idle for more than a few hours, or if it has been pumping liquids containing a large amount of solids, drain the pump, and flush it thoroughly with clean water. To prevent large solids from clogging the drain port and preventing the pump from completely draining, insert a rod or stiff wire in

the drain port, and agitate the liquid during the draining process. Clean out any remaining solids by flushing with a hose.

PUMP TROUBLESHOOTING - SECTION D

WARNING

```

////////////////////////////////////
//
// Before attempting to open or service the pump:
//
// 1. Familiarize yourself with this manual.
// 2. Shut down the engine and take precautions to en-
//     sure that the pump will remain inoperative.
// 3. Allow the pump to cool if overheated.
// 4. Vent the pump slowly and cautiously.
// 5. Close the suction and discharge valves.
// 6. Check the temperature before opening any covers,
//     plates, or plugs.
// 7. Drain the pump.
//
////////////////////////////////////
    
```

TROUBLE	POSSIBLE CAUSE	PROBABLE REMEDY
<p>PUMP FAILS TO PRIME</p>	<p>Not enough liquid in casing.</p> <p>Suction check valve contaminated or damaged.</p> <p>Air leak in suction line.</p> <p>Lining of suction hose collapsed.</p> <p>Leaking or worn seal or pump gasket.</p> <p>Suction lift or discharge head too high.</p> <p>Strainer clogged.</p>	<p>Add liquid to casing. See PRIMING.</p> <p>Clean or replace check valve.</p> <p>Correct leak.</p> <p>Replace suction hose.</p> <p>Check pump vacuum. Replace leaking or worn seal or gasket.</p> <p>Check piping installation and install bypass line if needed. See INSTALLATION.</p> <p>Check strainer and clean if necessary.</p>
<p>PUMP STOPS OR FAILS TO DELIVER RATED FLOW OR PRESSURE</p>	<p>Air leak in suction line.</p> <p>Suction intake not submerged at proper level or sump too small.</p> <p>Lining of suction hose collapsed.</p>	<p>Correct leak.</p> <p>Check installation and correct submergence as needed.</p> <p>Replace suction hose.</p>

TROUBLE	POSSIBLE CAUSE	PROBABLE REMEDY
PUMP STOPS OR FAILS TO DELIVER RATED FLOW OR PRES-SURE(cont.)	<p>Impeller or other wearing parts worn or damaged.</p> <p>Impeller clogged.</p> <p>Pump speed too slow.</p> <p>Suction lift or discharge head too high.</p> <p>Leaking or worn seal or pump gasket.</p> <p>Strainer clogged.</p>	<p>Replace worn or damaged parts. Check that impeller is properly centered and rotates freely.</p> <p>Free impeller of debris.</p> <p>Check engine output; consult engine operation manual.</p> <p>Check piping installation and install bypass line if needed. See INSTALLATION.</p> <p>Check pump vacuum. Replace leaking or worn seal or gasket.</p> <p>Check strainer and clean if necessary.</p>
PUMP REQUIRES TOO MUCH POWER	<p>Pump speed too high.</p> <p>Discharge head too low.</p> <p>Liquid solution too thick.</p>	<p>Check engine output.</p> <p>Adjust discharge valve.</p> <p>Dilute if possible.</p>
PUMP CLOGS FREQUENTLY	<p>Discharge flow too slow.</p> <p>Suction check valve or foot valve clogged or binding.</p> <p>Discharge line clogged or restricted; hose kinked.</p>	<p>Open discharge valve fully to increase flow rate, and run engine at maximum governed speed.</p> <p>Clean valve.</p> <p>Check discharge lines; straighten hose.</p>

TROUBLE	POSSIBLE CAUSE	PROBABLE REMEDY
EXCESSIVE NOISE	<p>Cavitation in pump.</p> <p>Pumping entrained air.</p> <p>Pump or drive not securely mounted.</p> <p>Impeller clogged or damaged.</p>	<p>Reduce suction lift and/or friction losses in suction line. Record vacuum and pressure gauge readings and consult local representative or factory.</p> <p>Locate and eliminate source of air bubble.</p> <p>Secure mounting hardware.</p> <p>Clean out debris; replace damaged parts.</p>
BEARINGS RUN TOO HOT	<p>Bearing temperature is high, but within limits.</p> <p>Low or incorrect lubricant.</p> <p>Suction and discharge lines not properly supported.</p> <p>Drive misaligned.</p>	<p>Check bearing temperature regularly to monitor any increase.</p> <p>Check for proper type and level of lubricant.</p> <p>Check piping installation for proper support.</p> <p>Align drive properly.</p>

PUMP MAINTENANCE AND REPAIR - SECTION E

MAINTENANCE AND REPAIR OF THE WEARING PARTS OF THE PUMP WILL MAINTAIN PEAK OPERATING PERFORMANCE.

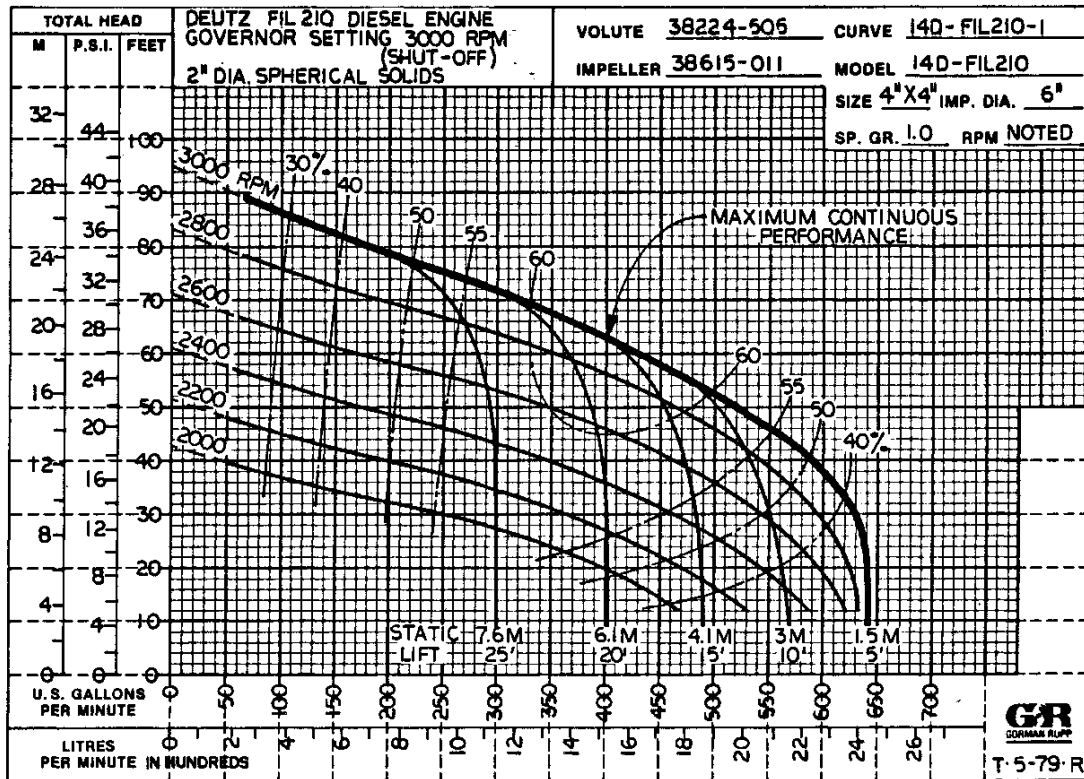

*STANDARD PERFORMANCE FOR PUMP MODEL 14D2-F1L 210

*Based on 70°F clear water at sea level with minimum suction lift. Since pump installations are seldom identical, your performance may be different due to such factors as viscosity, specific gravity, elevation, temperature, and impeller trim.

If your pump serial number is followed by an "N", your pump is NOT a standard production model. Contact the Gorman-Rupp Company to verify performance or part numbers.

CAUTION

Pump speed and operating condition points must be within the continuous performance range shown on the curve. See Section E, Page 1.

SECTIONAL DRAWING

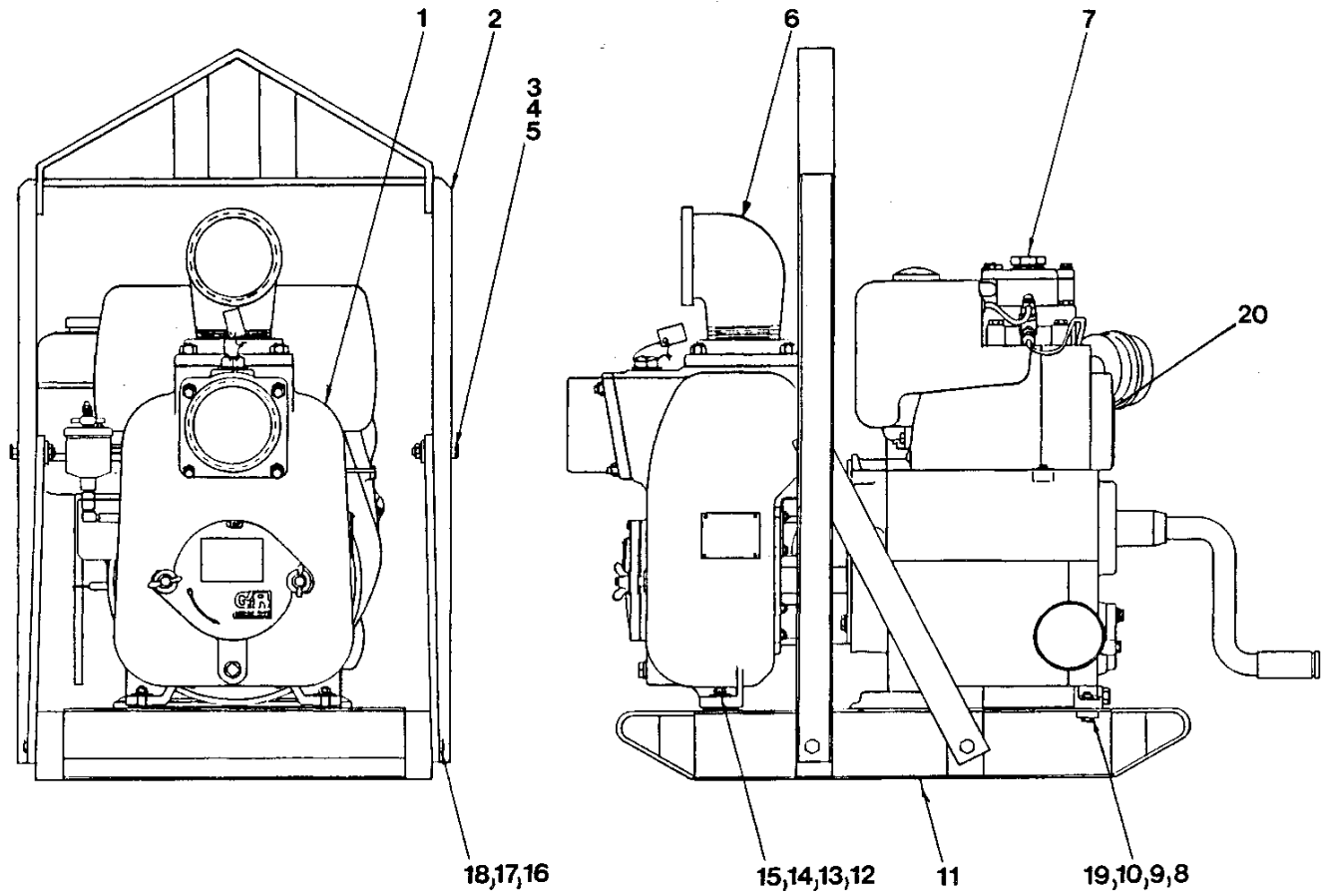

Figure 1. Pump Model 14D2-F1L 210

PARTS LIST
Pump Model 14D2-F1L 210
 (From S/N 794667 up)

If your pump serial number is followed by an "N", your pump is **NOT** a standard production model. Contact the Gorman-Rupp Company to verify part numbers.

ITEM NO.	PART NAME	PART NUMBER	MATL CODE	QTY
1	PUMP ASSY	14D2	-----	1
2	HOISTING BAIL	44714-035	24150	1
3	HEX HD CAPSCREW	B1006	15991	2
4	LOCKWASHER	J10	15991	2
5	HEX NUT	D10	15991	2
6	STREET ELBOW	RS64	11990	1
7	DEUTZ F1L ENGINE	29217-082	-----	1
8	HEX HD CAPSCREW	B0606	15991	4
9	LOCKWASHER	J06	15991	4
10	HEX NUT	D06	15991	4
11	COMBINATION BASE ASSY	41566-081	24150	1
12	HEX HD CAPSCREW	B0806	15991	2
13	FLAT WASHER	K08	15991	2
14	LOCKWASHER	J08	15991	2
15	HEX NUT	D08	15991	2
16	HEX HD CAPSCREW	B1006	15991	4
17	LOCKWASHER	J10	15991	4
18	HEX NUT	D10	15991	4
19	BEVELED WASHER	21167-008	-----	4
20	WARNING DECAL	38817-058	-----	1
NOT SHOWN:				
	WARNING DECAL	2613-FE	-----	1
OPTIONAL:				
	WHEEL KIT	GRP30-03A	-----	1

Above Serial Numbers Do Not Apply To Pumps Made In Canada.

CANADIAN SERIAL NO. AND UP

SECTIONAL DRAWING

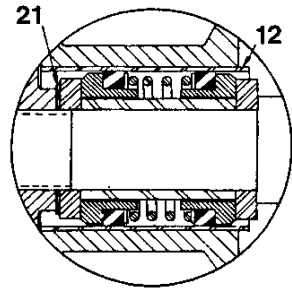

DETAIL OF SEAL

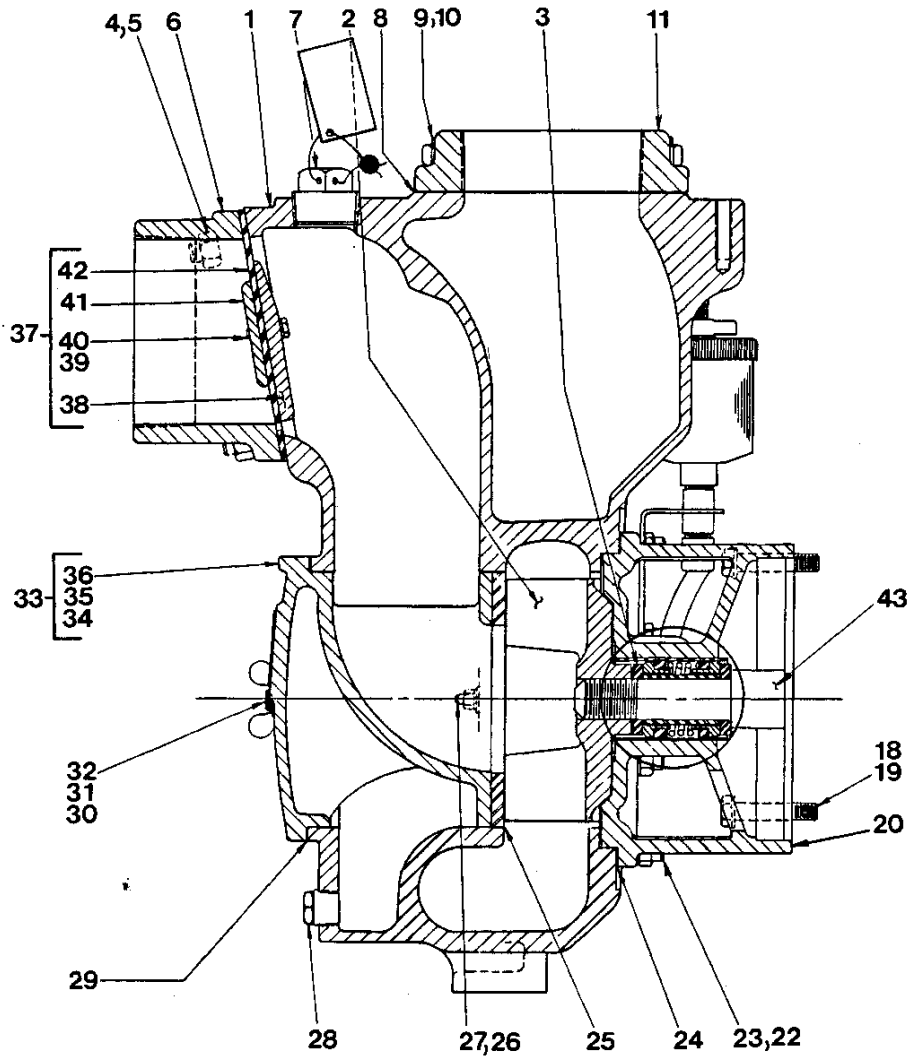
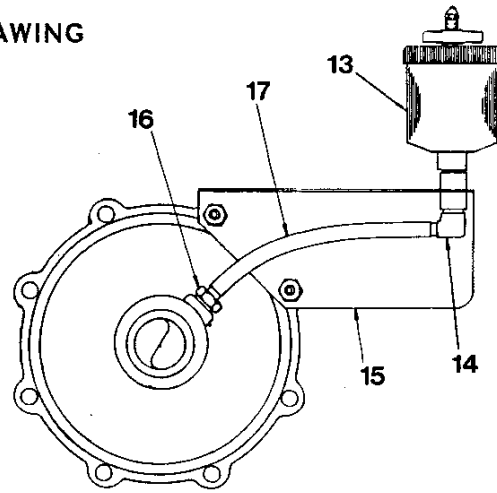

Figure 2. Pump End Assy 14D2-(F1L 210)

PARTS LIST
Pump End Assy 14D2-(F1L 210)

ITEM NO.	PART NAME	PART NUMBER	MATL CODE	QTY	ITEM NO.	PART NAME	PART NUMBER	MATL CODE	QTY
1	PUMP CASING	38224-513	10010	1	26	LOCKWASHER	J04	15991	2
2	*IMPELLER	38615-011	10010	1	27	HEX NUT	D04	15991	2
3	*SEAL ASSY	GS1000-C	-----	1	28	CASING DRAIN PLUG	P08	11990	1
4	STUD	C0808	15991	4	29	*COVER PLATE GSKT	38682-015	20000	1
5	HEX NUT	D08	15991	4	30	STUD	C0808	15991	2
6	SUCTION FLANGE	38645-506	10010	1	31	FLAT WASHER	K08	15991	2
7	FILL PLUG ASSY	48271-065	-----	1	32	COVER WING NUT	BB08	15991	2
8	*DISCH FLANGE GSKT	38687-009	20000	1	33	COVER PLATE ASSY	42111-911	-----	1
9	STUD	C1008	15991	4	34	-WARNING PLATE	2613-EV	13990	1
10	HEX NUT	D10	15991	4	35	-DRIVE SCREW	BM#04-03	15990	4
11	DISCHARGE FLANGE	38644-506	10010	1	36	-COVER PLATE	NOT AVAILABLE		1
12	*SEAL LINER	83	14080	REF	37	CHECK VALVE ASSY	46413-029	-----	1
13	*SEAL GREASE CUP	S1509	-----	1	38	* -VALVE WEIGHT	4718	10010	1
14	MALE ELBOW	26171-038	-----	1	39	-LOCKWASHER	J04	17000	2
15	MOUNTING BRACKET	41881-340	24150	1	40	-HEX HD CAPSCREW	B0403 1/2	17000	2
16	MALE CONNECTOR	26171-013	-----	1	41	* -VALVE WEIGHT	19	10010	1
17	*TUBING	31411-241	19550	1	42	* -CHECK VLV GSKT	38671-626	19070	1
18	HEX HD CAPSCREW	B0708	15991	4	43	STUB SHAFT	44111-005	24150	REF
19	LOCKWASHER	J07	15991	4		NOT SHOWN:			
20	INTERMEDIATE	5-B	10010	1		SUCTION STICKER	6588-AG	-----	1
21	*IMPELLER SHIM SET	2-X	17090	REF		DISCH STICKER	6588-BJ	-----	1
22	STUD	C0606	15991	8		NAME PLATE	38818-021	13990	1
23	HEX NUT	D06	15991	8		DRIVE SCREW	BM#04-03	15990	4
24	*CASING GSKT SET	48211-022	-----	1		STRAINER	2690	24000	1
25	*WEAR PLATE ASSY	46451-302	24150	1					

*INDICATES PARTS RECOMMENDED FOR STOCK

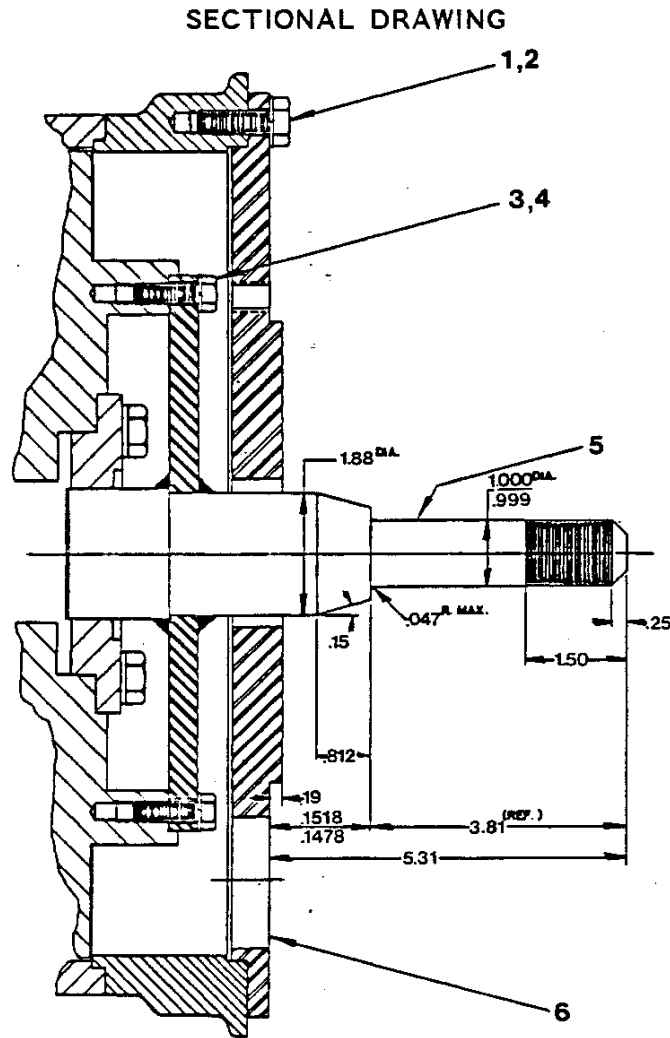

Figure 3. Drive Assembly For Pump Model 14D2-F1L 210

PARTS LIST

ITEM NO.	PART NAME	PART NUMBER	MATL CODE	QTY
1	HEX HD CAPSCREW	22645-164	-----	8
2	LOCKWASHER	21171-511	-----	8
3	HEX HD CAPSCREW	22645-132	-----	6
4	LOCKWASHER	21171-510	-----	6
5	STUB SHAFT ASSY	44111-005	24150	1
6	BELLOUSING ADAPTOR	31741-008	15990	1

*INDICATES PARTS RECOMMENDED FOR STOCK

PUMP AND SEAL DISASSEMBLY AND REASSEMBLY

This pump requires little service due to its rugged, minimum-maintenance design. However, if it becomes necessary to inspect or replace the wearing parts, follow these instructions which are keyed to the sectional view(s) (see Figures 1, 2 and 3) and the accompanying parts list(s).

Before attempting to service the pump, shut down the engine and take precautions to ensure that the engine will remain inoperative and close all valves in the suction and discharge lines.

For engine disassembly and repair, consult the literature supplied with the engine, or contact your local Deutz engine representative.

WARNING

```

////////////////////////////////////
//
// Before attempting to open or service the pump:
//
// 1. Familiarize yourself with this manual.
// 2. Shut down the engine and take precautions to en-
// sure that the pump will remain inoperative.
// 3. Allow the pump to cool if overheated.
// 4. Vent the pump slowly and cautiously.
// 5. Close the suction and discharge valves.
// 6. Check the temperature before opening any covers,
// plates, or plugs.
// 7. Drain the pump.
//
////////////////////////////////////

```

WARNING

```

////////////////////////////////////
//
// Use lifting and moving equipment in good repair and with
// adequate capacity to prevent injuries to personnel or
// damage to equipment.
//
////////////////////////////////////

```

Suction Check Valve Removal

(Figure 2)

Disconnect the suction piping. Remove the nuts (5) securing the suction flange (6) and check valve assembly (37) to the pump casing.

Inspect the check valve components and, if replacement is required, disengage the hardware (39 and 40) securing the parts.

Back Cover Removal

(Figure 2)

The wear plate assembly is easily accessible, and can be serviced after the back cover assembly (33) has been removed.

Before removing the assembly, remove the casing drain plug (28) and drain the pump. Clean and reinstall the drain plug.

Remove the wing nuts and flat washers (31 and 32), and pull the back cover and assembled wear plate (25) from the pump casing (1). Remove the back cover gasket (29).

Inspect the wear plate and, if replacement is required, remove the hardware (26 and 27) securing it to the back cover.

Pump Casing Removal

(Figure 1)

To service the impeller or seal assembly, disconnect the discharge piping. Remove the hardware (12, 13, 14 and 15) securing the pump casing to the base (11).

(Figure 2)

Remove the hardware (22 and 23) securing the pump casing and grease cup bracket (15) to the intermediate (20). Install a standard 5/8-11 UNC lifting eye in the tapped hole in the top of the pump casing. **Be sure** to screw the eye into the casing until fully engaged. Use a hoist and sling of suitable capacity to separate the pump casing from the intermediate.

WARNING

```

////////////////////////////////////
//                               //
// Do not attempt to lift the complete pump unit using the //
// lifting eye. It is designed to facilitate removal or //
// installation of individual components only. Additional //
// weight may result in damage to the pump or failure of //
// the eye bolt. //
//                               //
////////////////////////////////////

```

Remove any leveling shims used under the casing mounting feet. Tie and tag the shims for ease of reassembly.

Impeller Removal

(Figure 2)

Turn the cross arm on the automatic lubricating grease cup (13) clockwise until it rests against the cover (see Figure 5). This will prevent the grease from escaping when the impeller is removed.

To loosen the impeller (2), tap the vanes in a counterclockwise direction (when facing impeller) with a block of wood or a soft-faced mallet. Unscrew the impeller and replace it if cracked or badly worn. Use caution when removing the impeller; tension on the seal spring will be released as the impeller is unscrewed.

Slide the impeller adjusting shims (21) off the impeller shaft. For ease of re-assembly, tie and tag the shims, or measure and record their thickness.

Seal Removal

(Figure 2)

To remove the seal assembly (3), remove the grease cup and piping (13, 14, 16 and 17) from the intermediate (20).

Use a stiff wire with a hooked end to remove the stationary and rotating seal elements, packing rings, seal spring and shaft sleeve from the intermediate.

NOTE

The seal assembly may also be removed by disengaging the hardware (18 and 19) securing the intermediate to the engine bellhousing, and sliding the intermediate and seal assembly off the shaft as a single unit. Remove the rotating elements and shaft sleeve. Use a dowel of suitable size to press the remaining seal components from the intermediate.

Inspect the seal liner (12) for wear or grooves which could cause leakage or damage to the seal packing rings. The seal liner is a press fit in the intermediate, and does not normally require replacement. If replacement is necessary, see **Seal Installation**.

If no further disassembly is required, see **Seal Installation**.

Stub Shaft Removal

(Figure 3)

Inspect the stub shaft (5) for distortion, nicks or scratches, or thread damage. Dress small nicks and burrs with a fine file or emery cloth. Replace the shaft if defective.

If the stub shaft requires replacement, disengage the hardware (1 and 2), and remove the bellhousing adaptor (6). Remove the hardware (3 and 4), and slide the stub shaft (5) out of the engine flywheel.

Stub Shaft Installation

(Figure 3)

If removed, secure the replacement stub shaft to the engine flywheel with the hardware (3 and 4). Secure the adaptor (6) to the engine bellhousing with the hardware (1 and 2).

Seal Installation

(Figures 2 and 4)

Clean the seal cavity and shaft with a cloth soaked in fresh cleaning solvent.

WARNING

```

////////////////////////////////////
//
// Most cleaning solvents are toxic and flammable. Use //
// them only in a well-ventilated area free from excessive //
// heat, sparks, and flame. Read and follow all prec- //
// autions printed on solvent containers. //
// //
////////////////////////////////////

```

The seal is not normally reused because wear patterns on the finished faces cannot be realigned during reassembly. This could result in premature failure. If necessary to reuse an old seal in an emergency, **carefully** wash all metallic parts in fresh cleaning solvent and allow to dry thoroughly.

Handle the seal parts with extreme care to prevent damage. Be careful not to contaminate precision finished faces; even fingerprints on the faces can shorten seal life. If necessary, clean the faces with a non-oil based solvent and a clean lint free tissue. Wipe **lightly** in a concentric pattern to avoid scratching the faces.

Inspect the seal components for wear, scoring, grooves, and other damage that might cause leakage. Clean and polish the seal spacer sleeve, or replace it if there are nicks or cuts on either end. If any components are worn, replace the complete seal; **never mix old and new seal parts**.

If a replacement seal is being used, remove it from the container and inspect the precision finished faces to ensure that they are free of any foreign matter.

To ease installation of the seal, lubricate the packing rings and seal liner with water or a very **small** amount of oil, and apply a drop of light lubricating oil on the finished faces. Assemble the seal as follows, (see Figure 4).

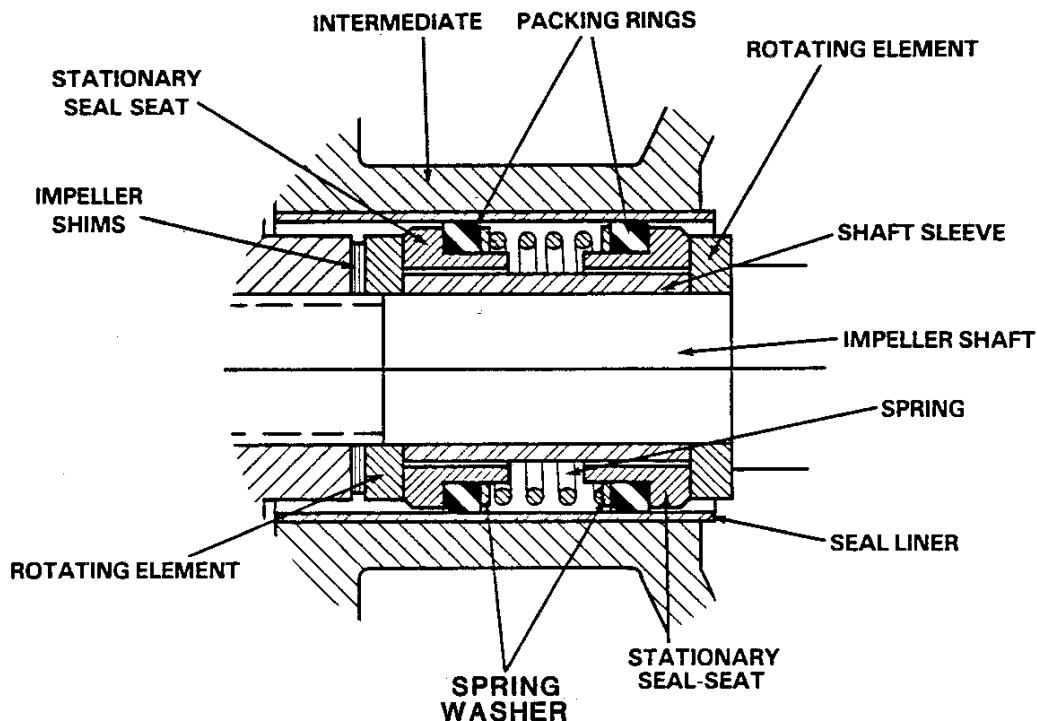

Figure 4. GS1000-C Seal Assembly

CAUTION

This seal is not designed for operation at temperatures above 110°F. Do not use at higher operating temperatures.

Inspect the intermediate, seal liner, and impeller shaft for burrs or sharp corners, and remove any that exist. Replace the seal liner (12) if wear or grooves exist which could cause leakage or damage to the seal packing rings. If the seal liner must be replaced, position the intermediate (20) on the bed of an arbor (or hydraulic) press and use a new sleeve to force the old one out. After the new liner is installed, drill a 1/4 inch diameter hole through it to permit the flow of lubricant to the seal. **Be careful** to center the drill in the threaded hole so not to damage the threads. Deburr the hole from the inside of the seal liner after drilling.

Slide the intermediate onto the shaft until fully seated against the bellhousing adaptor. Be sure the threaded seal lubricant hole in the intermediate is positioned as shown in Figure 2, and secure the intermediate with the hardware (18 and 19).

Position the inboard rotating element on the shaft with the chamfered side toward the shaft shoulder, and slide it on until fully seated against the shoulder.

Subassemble the inboard stationary seat, packing ring, and stationary washer. Press this subassembly into the lubricated seal liner until the seal faces contact. A push tube cut from a length of plastic pipe would aid this installation. The I.D. of the tube should be approximately the same size as the I.D. of the seal spring.

Install the spacer sleeve and seal spring.

Subassemble the outboard stationary seat, packing ring, and stationary washer. Press this subassembly into the seal liner and install the outboard rotating element.

Reinstall the automatic grease cup and piping (13, 14, 16 and 17).

Lubricate the seal as indicated in LUBRICATION, after the impeller has been installed.

Impeller Installation And Adjustment

(Figure 2)

Inspect the impeller, and replace it if cracked or badly worn.

Slide the same thickness of impeller adjusting shims (21) as previously removed onto the shaft and screw the impeller on until tight.

A clearance of .020 to .040 inch between the impeller and the intermediate is necessary for maximum pump efficiency. Measure this clearance, and add or remove impeller shims until it is reached.

Pump Casing Installation

(Figure 2)

Install the same thickness of casing gaskets (24) as previously removed, and secure the pump casing and grease cup bracket (15) to the intermediate with the nuts (23). **Do not** fully tighten the nuts (23) until the impeller face clearance has been set.

NOTE

If the pump has been completely disassembled, it is recommended that the back cover assembly be reinstalled at this point. The back cover assembly must be in place to adjust the impeller face clearance.

A clearance of .008 to .015 inch between the impeller and the wear plate is also recommended for maximum pump efficiency. This clearance must be set after installing the back cover, by adding or removing gaskets in the pump casing gasket set (24) until the impeller binds against the wear plate when the shaft is turned. After the impeller binds, add .015 inch of gaskets.

NOTE

An alternate method of adjusting this clearance is to reach through the discharge port with a feeler gauge and measure the gap. Add or subtract pump casing gaskets accordingly.

When this clearance has been properly set, tighten the nuts (23) and secure the casing to the base with the hardware (12, 13, 14 and 15, Figure 1). Be sure to reinstall any leveling shims used under the casing mounting feet.

If a lifting eye was used to move the pump casing, **be sure** to remove the eye from the casing before putting the pump back into service.

WARNING

```

////////////////////////////////////
//                               //
// Do not attempt to lift the complete pump unit using the //
// lifting eye. It is designed to facilitate removal or //
// installation of individual components only. Additional //
// weight may result in damage to the pump or failure of //
// the eye bolt. //
//                               //
////////////////////////////////////

```

Back Cover Installation

(Figure 2)

If the wear plate (25) was removed for replacement, carefully center it on the back cover and secure it with the hardware (26 and 27). The wear plate must be concentric to prevent binding when the back cover is installed.

Clean any scale or debris from the contacting surfaces in the pump casing that might prevent a good seal with the back cover. Replace the back cover gasket (29) and slide the back cover assembly into the pump casing. Be sure the wear plate does not bind against the impeller.

NOTE

To ease future disassembly, apply a film of grease or 'Never-Seez' on the back cover shoulder, or any surface which contacts the pump casing. This action will reduce rust and scale build-up.

Secure the back cover assembly with the flat washers and wing nuts (31 and 32). **Do not** over-tighten the wing nuts; they should be just tight enough to ensure a good seal at the back cover shoulder.

Suction Check Valve Installation

(Figure 2)

Inspect the check valve components, and replace parts that are badly worn. Secure the check valve gasket (42) and weights with the hardware (39 and 40).

Position the check valve assembly in the suction opening with the large weight (38) toward the inside of the pump casing, and the small weight (41) toward the suction flange (6). Secure the suction flange and check valve assembly to the pump casing with the nuts (5).

Final Pump Reassembly

(Figure 1)

Be sure the pump is secured to the base and engine.

Install the suction and discharge lines, and open all valves. Make certain that all piping connections are tight, properly supported and secure.

Be sure the pump end and engine have been properly lubricated, see LUBRICATION.

Fill the pump casing with clean liquid. Reinstall the fill plug and tighten it.

Refer to OPERATION, Section C, and start the pump.

LUBRICATION

Seal Assembly

(Figure 2)

Fill the grease cup (13) through the grease fitting with No. 2 lithium base grease until grease escapes from the relief hole. Turn the grease cup arm counterclockwise until it is at the top of the stem; this will release the spring to apply grease to the seal (see Figure 5).

NOTE

Bleed off the seal cavity and supply lines to eliminate an air pocket in the seal area.

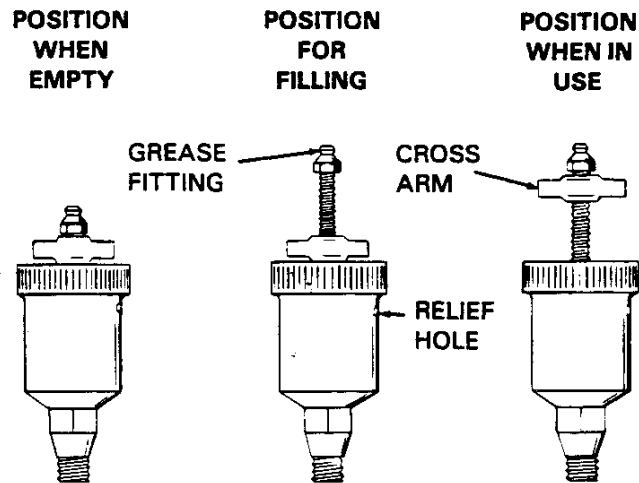

Figure 5. Automatic Lubricating Grease Cup

Engine

Consult the literature supplied with the engine, or contact your local Deutz engine representative.

**For U.S. and International Warranty Information,
Please Visit www.grpumps.com/warranty**

or call:

U.S.: 419-755-1280

International: +1-419-755-1352

**For Canadian Warranty Information,
Please Visit www.grcanada.com/warranty**

or call:

519-631-2870

THE GORMAN-RUPP COMPANY • MANSFIELD, OHIO

GORMAN-RUPP OF CANADA LIMITED • ST. THOMAS, ONTARIO, CANADA