

**INSTALLATION, OPERATION,
AND MAINTENANCE MANUAL**
WITH PARTS LIST

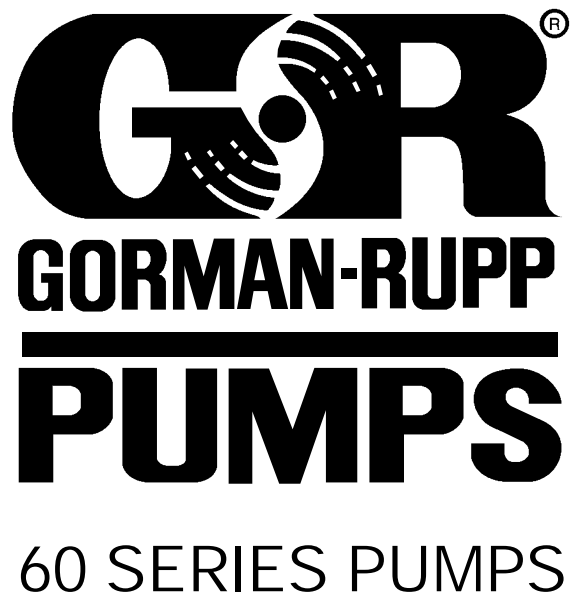

MODEL
64B2-F5L

THE GORMAN-RUPP COMPANY D MANSFIELD, OHIO

www.gormanrupp.com

GORMAN-RUPP OF CANADA LIMITED D ST. THOMAS, ONTARIO, CANADA

Printed in U.S.A.

©Copyright by the Gorman-Rupp Company



The engine exhaust from this product contains chemicals known to the State of California to cause cancer, birth defects or other reproductive harm.

TABLE OF CONTENTS

INTRODUCTION	PAGE I – 1
SAFETY - SECTION A	PAGE A – 1
INSTALLATION – SECTION B	PAGE B – 1
Pump Dimensions	PAGE B – 1
PREINSTALLATION INSPECTION	PAGE B – 1
Battery Specifications And Installation	PAGE B – 2
POSITIONING PUMP	PAGE B – 2
Lifting	PAGE B – 2
Mounting	PAGE B – 2
SUCTION AND DISCHARGE PIPING	PAGE B – 3
Materials	PAGE B – 3
Line Configuration	PAGE B – 3
Connections to Pump	PAGE B – 3
Gauges	PAGE B – 3
SUCTION LINES	PAGE B – 3
Fittings	PAGE B – 3
Strainers	PAGE B – 3
Sealing	PAGE B – 3
Suction Lines In Sumps	PAGE B – 3
Suction Line Positioning	PAGE B – 4
FLOAT SWITCHES	PAGE B – 4
Installation	PAGE B – 4
DISCHARGE LINES	PAGE B – 5
Siphoning	PAGE B – 5
Valves	PAGE B – 5
ALIGNMENT	PAGE B – 6
OPERATION – SECTION C	PAGE C – 1
PRIMING	PAGE C – 1
Hand-Operated Priming Pump	PAGE C – 1
STARTING	PAGE C – 1
Manual Starting	PAGE C – 2
Automatic Starting	PAGE C – 2
OPERATION	PAGE C – 3
Leakage	PAGE C – 3
Liquid Temperature And Overheating	PAGE C – 3
Strainer Check	PAGE C – 3
Pump Vacuum Check	PAGE C – 3
STOPPING	PAGE C – 3
Manual Stopping	PAGE C – 3
Automatic Stopping	PAGE C – 4
Safety Shutdown System	PAGE C – 4
OPERATION IN EXTREME HEAT	PAGE C – 4
BEARING TEMPERATURE CHECK	PAGE C – 4
Cold Weather Preservation	PAGE C – 5

TABLE OF CONTENTS
(continued)

TROUBLESHOOTING – SECTION D	PAGE D – 1
PREVENTIVE MAINTENANCE	PAGE D – 3
PUMP MAINTENANCE AND REPAIR - SECTION E	PAGE E – 1
STANDARD PERFORMANCE CURVE	PAGE E – 1
PARTS LISTS:	
Pump Model	PAGE E – 3
Pump End Assy	PAGE E – 5
Drive Assembly	PAGE E – 6
PUMP AND SEAL DISASSEMBLY AND REASSEMBLY	PAGE E – 7
Suction Head Removal	PAGE E – 7
Separating Pump And Intermediate From Engine	PAGE E – 8
Impeller Removal	PAGE E – 8
Seal Removal and Disassembly	PAGE E – 8
Shaft And Bearing Removal And Disassembly	PAGE E – 9
Shaft and Bearing Reassembly and Installation	PAGE E – 10
Seal Reassembly and Installation	PAGE E – 11
Impeller Installation	PAGE E – 13
Securing Pump And Intermediate To Engine	PAGE E – 13
Suction Head Installation	PAGE E – 14
Final Pump Assembly	PAGE E – 14
LUBRICATION	PAGE E – 14
Seal Assembly	PAGE E – 14
Bearings	PAGE E – 15
Engine	PAGE E – 15

INTRODUCTION

Thank You for purchasing a Gorman-Rupp pump. **Read this manual** carefully to learn how to safely install and operate your pump. Failure to do so could result in personal injury or damage to the pump.

This Installation, Operation, and Maintenance manual is designed to help you achieve the best performance and longest life from your Gorman-Rupp pump. This pump is a 60 Series, enclosed impeller, centrifugal model, designed for high pressure distribution of clean liquids containing specified entrained solids. It is powered by a five cylinder, air-cooled Deutz diesel engine, model F5L. The basic material of construction for wetted parts is gray iron, with a gray iron impeller and brass wearing parts. Be sure the liquid being pumped is compatible with these materials.

If there are any questions regarding the pump or its application which are not covered in this manual or in other literature accompanying this unit, please contact your Gorman-Rupp distributor, or write:

The Gorman-Rupp Company
 P.O. Box 1217
 Mansfield, Ohio 44901--1217
 Phone: (419) 755--1011
 or:
Gorman-Rupp of Canada Limited
 70 Burwell Road
 St. Thomas, Ontario N5P 3R7
 Phone: (519) 631--2870

For information or technical assistance on the engine, contact the engine manufacturer's local dealer or representative.

Because pump installations are seldom identical, this manual cannot possibly provide detailed instructions and precautions for every aspect of each specific application. Therefore, it is the responsibility of the owner/installer of the pump to ensure that applications not addressed in this manual are performed **only** after establishing that neither operator safety nor pump integrity are com-

promised by the installation. Pumps and related equipment **must** be installed and operated according to all national, local and industry standards.

The following are used to alert maintenance personnel to procedures which require special attention, to those which could damage equipment, and to those which could be dangerous to personnel:



Immediate hazards which WILL result in severe personal injury or death. These instructions describe the procedure required and the injury which will result from failure to follow the procedure.



Hazards or unsafe practices which COULD result in severe personal injury or death. These instructions describe the procedure required and the injury which could result from failure to follow the procedure.



Hazards or unsafe practices which COULD result in minor personal injury or product or property damage. These instructions describe the requirements and the possible damage which could result from failure to follow the procedure.

NOTE

Instructions to aid in installation, operation, and maintenance, or which clarify a procedure.

SAFETY - SECTION A

This information applies to 60 Series Engine Driven Pumps. Refer to the manual accompanying the engine before attempting to begin operation.

Because pump installations are seldom identical, this manual cannot possibly provide detailed instructions and precautions for each specific application. Therefore, it is the owner/installer's responsibility to ensure that applications not addressed in this manual are performed only after establishing that neither operator safety nor pump integrity are compromised by the installation.



Before attempting to open or service the pump:

1. Familiarize yourself with this manual.
2. Switch off the engine ignition and disconnect the positive battery cable to ensure that the pump will remain inoperative.
3. Allow the pump to completely cool if overheated.
4. Check the temperature before opening any covers, plates, or plugs.
5. Close the suction and discharge valves.
6. Vent the pump slowly and cautiously.
7. Drain the pump.



If the pump is equipped with the optional automatic starting system, it is subject to automatic restart. Keep hands

and clothing away from the unit to prevent injury during automatic operation. Disconnect the positive battery cable before performing any maintenance. Failure to do so may result in serious personal injury.



This pump is designed to handle clean liquids containing specified entrained solids. Do not attempt to pump volatile, corrosive, or flammable liquids which may damage the pump or endanger personnel as a result of pump failure.



Use lifting and moving equipment in good repair and with adequate capacity to prevent injuries to personnel or damage to equipment. Suction and discharge hoses and piping must be removed from the pump before lifting.



After the pump has been installed, make certain that the pump and all piping or hose connections are tight, properly supported and secure before operation.



Do not operate the pump against a closed discharge valve for long periods of time. If operated against a closed discharge valve, pump components will deteriorate, and the liquid could come to a boil, build pressure, and cause the pump casing to rupture or explode.

**WARNING!**

Do not remove plates, covers, gauges, pipe plugs, or fittings from an overheated pump. Vapor pressure within the pump can cause parts being disengaged to be ejected with great force. Allow the pump to cool before servicing.

**DANGER!**

Do not operate an internal combustion engine in an explosive atmosphere. When operating internal combustion engines in an enclosed area, make certain that exhaust fumes are piped to the outside. These fumes contain carbon monoxide, a deadly gas that is colorless, tasteless, and odorless.

**WARNING!**

Fuel used by internal combustion engines presents an extreme explosion and fire hazard. Make certain that all fuel lines are securely connected and free of leaks. Never refuel a hot or running engine. Avoid overfilling the fuel tank. Always use the correct type of fuel.

**WARNING!**

Never tamper with the governor to gain more power. The governor establishes safe operating limits that should not be exceeded. The maximum continuous operating speed for this pump is 2400 RPM.

INSTALLATION – SECTION B

Review all SAFETY information in Section A.

Since pump installations are seldom identical, this section offers only general recommendations and practices required to inspect, position, and arrange the pump and piping.

Most of the information pertains to a standard **static lift** application where the pump is positioned above the free level of liquid to be pumped.

If installed in a **flooded suction application** where the liquid is supplied to the pump under pressure, some of the information such as mounting, line configuration, and priming must be tailored to the specific application. Since the pressure supplied

to the pump is critical to performance and safety, **be sure** to limit the incoming pressure to 50% of the maximum permissible operating pressure as shown on the pump performance curve (see Section E, Page 1). Since this pump is fitted with a Gorman-Rupp double grease lubricated seal, the maximum incoming pressure must be reduced to 10 p.s.i.

For further assistance, contact your Gorman-Rupp distributor or the Gorman-Rupp Company.

Pump Dimensions

See Figure 1 for the approximate physical dimensions of this pump.

OUTLINE DRAWING

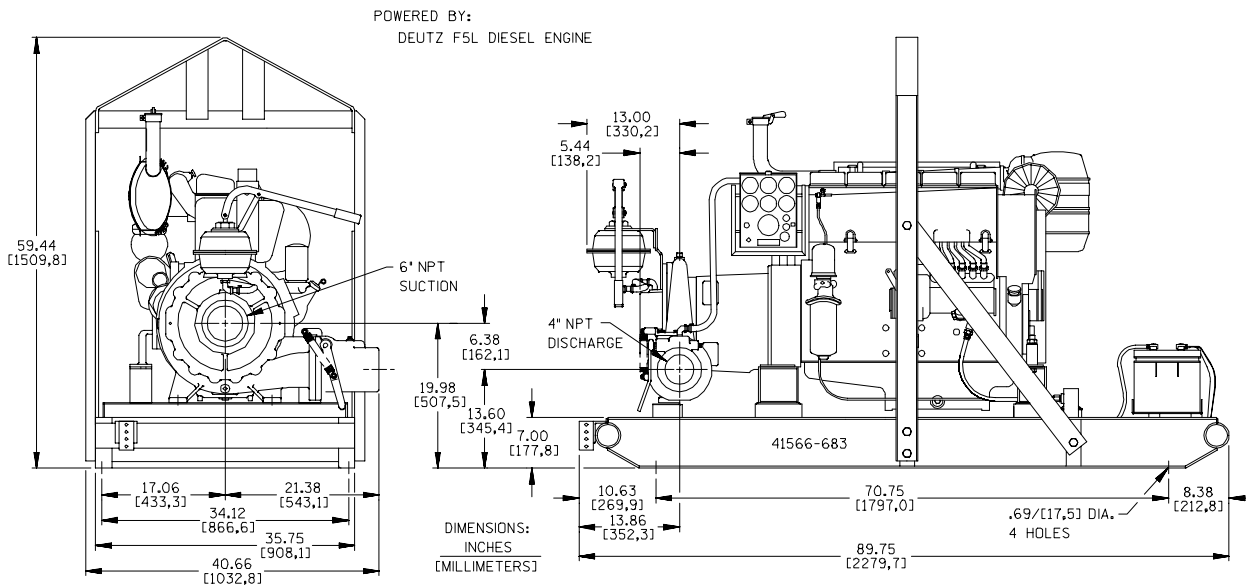

Figure 1. Pump Model 64B2–F5L

PREINSTALLATION INSPECTION

The pump assembly was inspected and tested before shipment from the factory. Before installation, inspect the pump for damage which may have occurred during shipment. Check as follows:

- Inspect the pump and engine for cracks, dents, damaged threads, and other obvious damage.
- Check for and tighten loose attaching hardware. Since gaskets tend to shrink after drying, check for loose hardware at mating surfaces.

- c. Carefully read all tags, decals, and markings on the pump assembly, and perform all duties indicated.
- d. Check levels and lubricate as necessary. Refer to **LUBRICATION** in the **MAINTENANCE AND REPAIR** section of this manual and perform duties as instructed.
- e. If the pump and engine have been stored for more than 12 months, some of the components or lubricants may have exceeded their maximum shelf life. These **must be inspected or replaced** to ensure maximum pump service.

If the maximum shelf life has been exceeded, or if anything appears to be abnormal, contact your Gorman-Rupp distributor or the factory to determine the repair or updating policy. **Do not** put the pump into service until appropriate action has been taken.

Battery Specifications And Installation

Unless otherwise specified on the pump order, the engine battery was **not** included with the unit. Refer to the following specifications when selecting a battery.

Table 1. Battery Specifications

Voltage	Cold Crank Amps @ 0°F	Reserve Capacity @80°F (Minutes)	Amp/ Hr. Rating	Approx. Overall Dims. (Inches)
12 Volts	960-975	365	175	20.5L x 8.75W x 9.75H

Refer to the information accompanying the battery and/or electrolyte solution for activation and charging instructions.

Before installing the battery, clean the positive and negative cable connectors, and the battery terminals. Secure the battery by tightening the holddown brackets. The terminals and clamps may be coated with petroleum jelly to retard corrosion. Connect and tighten the positive cable first, then the negative cable.

POSITIONING PUMP



Use lifting and moving equipment in good repair and with adequate capacity to prevent injuries to personnel or damage to equipment. Suction and discharge hoses and piping must be removed from the pump before lifting.

Lifting

Use lifting equipment with a capacity of at least **10,400 pounds (4717 kg)**. This pump weighs approximately **2,066 pounds (937 kg)**, not including the weight of accessories and optional wheel kit. Customer installed equipment such as suction and discharge piping **must** be removed before attempting to lift.



The pump assembly can be seriously damaged if the cables or chains used to lift and move the unit are improperly wrapped around the pump.

Mounting

Locate the pump in an accessible place as close as practical to the liquid being pumped. Level mounting is essential for proper operation.

The pump may have to be supported or shimmed to provide for level operation or to eliminate vibration.

If the pump has been mounted on a moveable base, make certain the base is stationary by setting the brake and blocking the wheels before attempting to operate the pump.

To ensure sufficient lubrication and fuel supply to the engine, **do not** position the pump and engine more than 15° off horizontal for continuous operation. The pump and engine may be positioned up to 30° off horizontal for **intermittent operation only**; however, the engine manufacturer should be

consulted for continuous operation at angles greater than 15°.

SUCTION AND DISCHARGE PIPING

Materials

Either pipe or hose may be used for suction and discharge lines; however, the materials must be compatible with the liquid being pumped. If hose is used in suction lines, it must be the rigid-wall, reinforced type to prevent collapse under suction. Using piping couplings in suction lines is not recommended.

Line Configuration

Keep suction and discharge lines as straight as possible to minimize friction losses. Make minimum use of elbows and fittings, which substantially increase friction loss. If elbows are necessary, use the long-radius type to minimize friction loss.

Connections to Pump

Before tightening a connecting flange, align it exactly with the pump port. Never pull a pipe line into place by tightening the flange bolts and/or couplings.

Lines near the pump must be independently supported to avoid strain on the pump which could cause excessive vibration, decreased bearing life, and increased shaft and seal wear. If hose-type lines are used, they should have adequate support to secure them when filled with liquid and under pressure.

Gauges

Most pumps are drilled and tapped for installing discharge pressure and vacuum suction gauges. If these gauges are desired for pumps that are not tapped, drill and tap the suction and discharge lines not less than 18 inches (457,2 mm) from the suction and discharge ports and install the lines. Installation closer to the pump may result in erratic readings.

SUCTION LINES

To avoid air pockets which could affect pump priming, the suction line must be as short and direct as possible. When operation involves a suction lift, the line must always slope upward to the pump from the source of the liquid being pumped; if the line slopes down to the pump at any point along the suction run, air pockets will be created.

Fittings

Suction lines should be the same size as the pump inlet. If reducers are used in suction lines, they should be the eccentric type, and should be installed with the flat part of the reducers uppermost to avoid creating air pockets. Valves are not normally used in suction lines, but if a valve is used, install it with the stem horizontal to avoid air pockets.

Strainers

If a strainer is furnished with the pump, be certain to use it; any spherical solids which pass through a strainer furnished with the pump will also pass through the pump itself.

If a strainer is not furnished with the pump, but is installed by the pump user, make certain that the total area of the openings in the strainer is at least three or four times the cross section of the suction line, and that the openings will not permit passage of solids larger than the solids handling capability of the pump.

This pump is designed to handle up to 13/32 inch (10,3 mm) diameter spherical solids.

Sealing

Since even a slight leak will affect priming, head, and capacity, especially when operating with a high suction lift, all connections in the suction line should be sealed with pipe dope to ensure an airtight seal. Follow the sealant manufacturer's recommendations when selecting and applying the pipe dope. The pipe dope should be compatible with the liquid being pumped.

Suction Lines In Sumps

If a single suction line is installed in a sump, it should be positioned away from the wall of the

sump at a distance equal to 1 1/2 times the diameter of the suction line.

If there is a liquid flow from an open pipe into the sump, the flow should be kept away from the suction inlet because the inflow will carry air down into the sump, and air entering the suction line will reduce pump efficiency.

If it is necessary to position inflow close to the suction inlet, install a baffle between the inflow and the suction inlet at a distance 1-1/2 times the diameter of the suction pipe. The baffle will allow entrained air to escape from the liquid before it is drawn into the suction inlet.

If two suction lines are installed in a single sump, the flow paths may interact, reducing the efficiency of one or both pumps. To avoid this, position the suction inlets so that they are separated by a dis-

tance equal to at least 3 times the diameter of the suction pipe.

Suction Line Positioning

The depth of submergence of the suction line is critical to efficient pump operation. Figure 2 shows recommended minimum submergence vs. velocity.

NOTE

The pipe submergence required may be reduced by installing a standard pipe increaser fitting at the end of the suction line. The larger opening size will reduce the inlet velocity. Calculate the required submergence using the following formula based on the increased opening size (area or diameter).

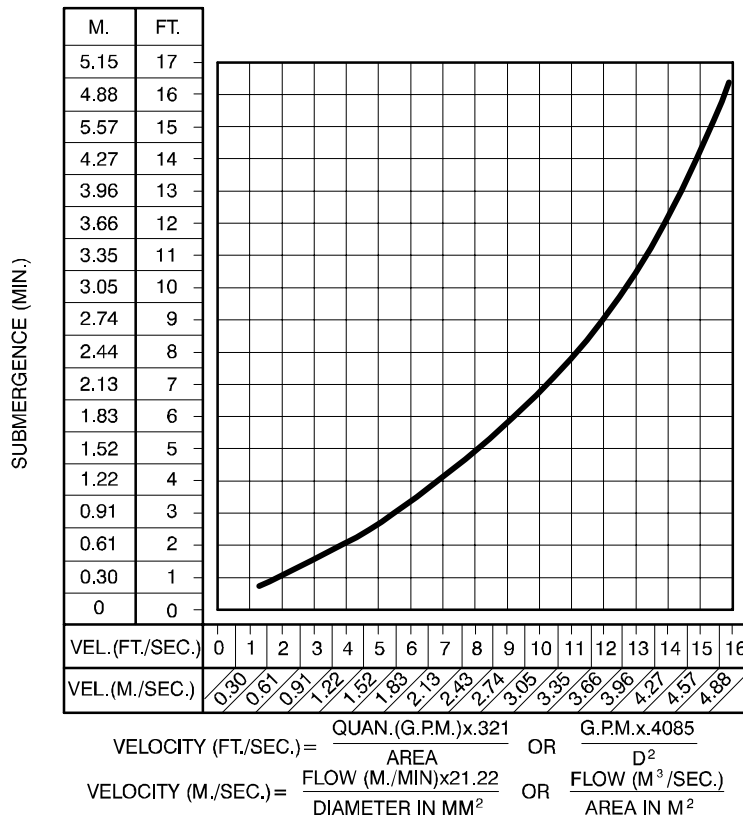

Figure 2. Recommended Minimum Suction Line Submergence vs. Velocity

DISCHARGE LINES

Siphoning

Do not terminate the discharge line at a level lower than that of the liquid being pumped unless a siphon breaker is used in the line. Otherwise, a si-

phoning action causing damage to the pump could result.

Valves

The spring-loaded check valve provided with this pump will **not** function as a discharge check valve

in system piping. It is intended to prevent recirculation of air during the priming cycle.

If a throttling valve is desired in the discharge line, use a valve as large as the largest pipe to minimize friction losses. Never install a throttling valve in a suction line.

With high discharge heads, it is recommended that a throttling valve and a system check valve be installed in the discharge line to protect the pump from excessive shock pressure and reverse rotation when it is stopped.



If the application involves a high discharge head, gradually close the discharge throttling valve before stopping the pump.

ALIGNMENT

The alignment of the pump and the engine is critical for trouble-free mechanical operation. See Section E, **Securing Pump And Intermediate To Engine** for detailed information.

OPERATION – SECTION C

Review all SAFETY information in Section A.

Follow the instructions on all tags, labels and decals attached to the pump.



Do not operate an internal combustion engine in an explosive atmosphere. When operating internal combustion engines in an enclosed area, make certain that exhaust fumes are piped to the outside. These fumes contain carbon monoxide, a deadly gas that is colorless, tasteless, and odorless.



This pump is designed to handle clean liquids containing specified entrained solids. Do not attempt to pump volatile, corrosive, or flammable liquids which may damage the pump or endanger personnel as a result of pump failure.



Never tamper with the governor to gain more power. The governor establishes safe operating limits that should not be exceeded. The maximum continuous operating speed for this pump is 2400 RPM.

PRIMING

Install the pump and piping as described in **INSTALLATION**. Make sure that the piping connections are tight, and that the pump is securely mounted. Check that the pump is properly lubricated (see **LUBRICATION** in **MAINTENANCE AND REPAIR**).

Since this pump is not self-priming, it is equipped with a hand-operated vacuum priming pump and a spring-loaded check valve.

Hand-Operated Priming Pump

The hand-operated priming pump (see Figure 1) is designed to prime the pump by evacuating air from the pump casing and suction line. It can be used while the pump is either stopped or operating. To prime the pump, close the discharge line throttling valve, and close the spring-loaded check valve before engaging the priming device. Open the ball valve in the priming line and operate the handle until liquid flows into the priming line sight gauge.

NOTE

For installation and operating instructions on the discharge check valve, see the separate check valve manual accompanying this literature.

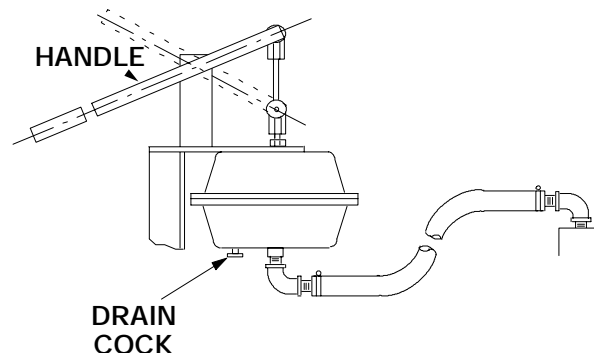

Figure 1. Hand Primer Assembly

Once the pump is fully primed, close the ball valve in the priming line, and open the discharge line throttling valve.

STARTING

Consult the operations manual furnished with the engine.

NOTE

This pump is equipped with a safety shut down device to terminate engine operation if pump dis-

charge pressure falls below 30 psi. During engine start up, the button on the discharge pressure gauge must be depressed to over-ride this safety feature.

Manual Starting

On initial start-up, set the engine speed at the half-throttle position. Depress the button on the discharge pressure gauge and turn the keyswitch on the control box to the "START" position until the engine starts. Release the key and the switch will return to the "RUN" position.

After the engine starts and the unit is fully primed, adjust the engine RPM until the desired flow rate is achieved.

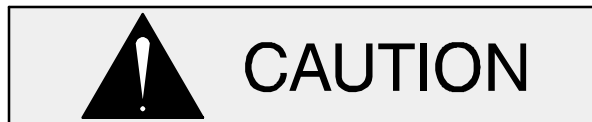

Pump speed and operating condition points must be within the continuous performance range shown on the curve on page E-1.

OPERATION



Pump speed and operating condition points must be within the continuous performance range shown on the curve. (See Section E, Page 1.)

Leakage

No leakage should be visible at pump mating surfaces, or at pump connections or fittings. Keep all line connections and fittings tight to maintain maximum pump efficiency.

Liquid Temperature And Overheating

The **maximum** liquid temperature for this pump is 110_ F (43_C). Do not apply it at a higher operating temperature.

Overheating can occur if operated with the valves in the suction or discharge lines closed. Operating against closed valves could bring the liquid to a boil, build pressure, and cause the pump to rupture or explode. If overheating occurs, stop the pump and allow it to cool before servicing it. Refill the pump casing with cool liquid.



Do not remove plates, covers, gauges, pipe plugs, or fittings from an overheated pump. Vapor pressure within the pump can cause parts being disengaged to be ejected with great force. Allow the pump to cool before servicing.

Strainer Check

If a suction strainer has been shipped with the pump or installed by the user, check the strainer regularly, and clean it as necessary. The strainer should also be checked if pump flow rate begins to drop. If a vacuum suction gauge has been installed, monitor and record the readings regularly to detect strainer blockage.

Never introduce air or steam pressure into the pump casing or piping to remove a blockage. This could result in personal injury or damage to the equipment. If backflushing is absolutely necessary, **liquid pressure** must be limited to 50% of the maximum permissible operating pressure shown on the pump performance curve. (See Section E, Page 1.) If the pump is fitted with a Gorman-Rupp double grease lubricated seal, the maximum incoming pressure must be reduced to 10 p.s.i.

Pump Vacuum Check

Since this pump does not have a suction check valve, the discharge line must be fitted with a check valve if a pump vacuum reading is to be taken.

With the pump inoperative, install a vacuum gauge in the system, using pipe dope on the threads. Block the suction line and start the pump. At operating speed the pump should pull a vacuum of 20 inches (508 mm) or more of mercury. If it does not, check for air leaks in the seal, gasket, or discharge valve.

Open the suction line, and read the vacuum gauge with the pump primed and at operation speed. Shut off the pump. The vacuum gauge reading will immediately drop proportionate to static suction lift, and should then stabilize. If the vacuum reading falls off rapidly after stabilization, an air leak exists. Before checking for the source of the leak, check the point of installation of the vacuum gauge.

STOPPING

Never halt the flow of liquid suddenly. If the liquid being pumped is stopped abruptly, damaging shock waves can be transmitted to the pump and piping system. Close all connecting valves slowly.

Manual Stopping

On engine driven pumps, reduce the throttle speed slowly and allow the engine to idle briefly before stopping.

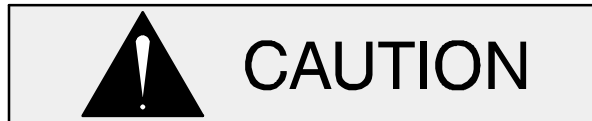

If the application involves a high discharge head, gradually close the discharge throttling valve before stopping the pump.

After stopping the pump, switch off the engine ignition and remove the key to ensure that the pump will remain inoperative.

Safety Shutdown System

The unit is equipped with a safety system to automatically shut down the engine under certain conditions. The engine will automatically shut down:

1. If the engine exceeds its safe operating temperature.
2. If the engine oil pressure drops below design limits.
3. If the engine fails to start within a pre-set period of time.
4. If the engine speed exceeds the safe operating range.
5. If the pump discharge pressure drops below 30 psi.

Lights on the control panel will indicate which of the safety features has caused the engine to shut down.

Should any of the safety features cause the engine to shut down, **the cause must be determined and corrected** before putting the unit back into service. The engine **will not restart** until the key switch has been returned to the 'OFF' position for at least 10 seconds.

All safety shutdown features are pre-set at the factory for optimum performance and safety; **do not** attempt to adjust these settings.



Never disconnect any of the safety shutdown features; this will void the warranty and could result in serious damage to the unit and/or injury to personnel. Safety shutdown features are pre-set at the factory; do not attempt to adjust any of the settings. Determine the cause of shutdown before putting the unit back into service. Consult the factory for additional information.

OPERATION IN EXTREME HEAT

The safety shutdown system will automatically stop the unit if engine operating temperature exceeds design limits. If engine over-temperature shutdown occurs, allow the unit to cool before re-starting.

If engine overheating continues, check the engine lubricant level and viscosity. Consult the engine operation manual for the recommended lubricant for operation in extreme heat.

If the unit is equipped with the optional auto-start control, the float(s) may need to be adjusted to allow shorter run and longer cooling periods, if possible.



If the pump is equipped with the optional automatic starting system, it is sub-

ject to automatic restart. Keep hands and clothing away from the unit to prevent injury during automatic operation. Disconnect the battery before performing any maintenance. Failure to do so may result in serious personal injury.

BEARING TEMPERATURE CHECK

Bearings normally run at higher than ambient temperatures because of heat generated by friction. Temperatures up to 160_F (71_C) are considered normal for bearings, and they can operate safely to at least 180_F (82_C).

Checking bearing temperatures by hand is inaccurate. Bearing temperatures can be measured accurately by placing a contact-type thermometer against the housing. Record this temperature for future reference.

A sudden increase in bearing temperatures is a warning that the bearings are at the point of failing to operate properly. Make certain that the bearing lubricant is of the proper viscosity and at the cor-

rect level (see **LUBRICATION** in Section E). Bearing overheating can also be caused by shaft misalignment and/or excessive vibration.

When pumps are first started, the bearings may seem to run at temperatures above normal. Continued operation should bring the temperatures down to normal levels.

Cold Weather Preservation

In below freezing conditions, drain the pump to prevent damage from freezing. Also, clean out any solids by flushing with a hose. Operate the pump for approximately one minute; this will remove any remaining liquid that could freeze the pump rotating parts. If the pump will be idle for more than a few hours, or if it has been pumping liquids containing a large amount of solids, drain the pump, and flush it thoroughly with clean water. To prevent large solids from clogging the drain port and preventing the pump from completely draining, insert a rod or stiff wire in the drain port, and agitate the liquid during the draining process. Clean out any remaining solids by flushing with a hose.

TROUBLESHOOTING – SECTION D

Review all SAFETY information in Section A.



Before attempting to open or service the pump:

1. Familiarize yourself with this manual.
2. Switch off engine ignition and disconnect the positive battery cable to ensure that the pump will remain inoperative.
3. Allow the pump to completely cool if overheated.
4. Check the temperature before opening any covers, plates, or plugs.

5. Close the suction and discharge valves.
6. Vent the pump slowly and cautiously.
7. Drain the pump.



If the pump is equipped with the optional automatic starting system, it is subject to automatic restart. Keep hands and clothing away from the unit to prevent injury during automatic operation. Disconnect the positive battery cable before performing any maintenance. Failure to do so may result in serious personal injury.

Table 1. Trouble Shooting Chart

TROUBLE	POSSIBLE CAUSE	PROBABLE REMEDY
PUMP FAILS TO PRIME	<p>Air leak in suction line.</p> <p>Lining of suction hose collapsed.</p> <p>Leaking or worn seal or pump gasket.</p> <p>Suction lift or discharge head too high.</p> <p>Strainer clogged.</p> <p>Auxiliary priming device faulty or improperly installed.</p>	<p>Correct leak.</p> <p>Replace suction hose.</p> <p>Check pump vacuum. Replace leaking or worn seal or gasket.</p> <p>Check piping installation and install bypass line if needed. See INSTALLATION.</p> <p>Check strainer and clean if necessary.</p> <p>Repair priming device or check installation.</p>
PUMP STOPS OR FAILS TO DELIVER RATED FLOW OR PRESSURE	<p>Air leak in suction line.</p> <p>Lining of suction hose collapsed.</p> <p>Discharge throttling valve partially closed; check valve installed improperly.</p>	<p>Correct leak.</p> <p>Replace suction hose.</p> <p>Open discharge valve fully; check piping installation.</p>

Table 1. Trouble Shooting Chart (cont.)

TROUBLE	POSSIBLE CAUSE	PROBABLE REMEDY
PUMP STOPS OR FAILS TO DELIVER RATED FLOW OR PRESSURE (cont.)	<p>Pump speed too high.</p> <p>Strainer clogged.</p> <p>Discharge pressure at or below safety shutdown limit.</p> <p>Impeller or other wearing parts worn or damaged.</p> <p>Impeller clogged.</p> <p>Discharge check valve locked closed.</p> <p>Suction lift too high.</p> <p>Pump speed too slow.</p>	<p>Check engine output.</p> <p>Check strainer and clean if necessary.</p> <p>Check starting instructions; increase pressure.</p> <p>Replace worn or damaged parts. Check that impeller is properly centered and rotates freely.</p> <p>Free impeller of debris.</p> <p>Check position of handle; open valve.</p> <p>Measure lift w/vacuum gauge. Reduce lift and/or friction losses in suction line.</p> <p>Check engine output; consult engine operation manual.</p>
PUMP REQUIRES TOO MUCH POWER	<p>Pump speed too high.</p> <p>Discharge head too low.</p> <p>Liquid solution too thick.</p> <p>Bearing(s) frozen.</p>	<p>Check engine output.</p> <p>Adjust discharge valve.</p> <p>Dilute if possible.</p> <p>Disassemble pump and check bearing(s).</p>
PUMP CLOGS FREQUENTLY	<p>Discharge flow too slow.</p> <p>Suction check valve or foot valve clogged or binding.</p>	<p>Open discharge valve fully to increase flow rate, and run engine at maximum governed speed.</p> <p>Clean valve.</p>
EXCESSIVE NOISE	<p>Cavitation in pump.</p> <p>Pumping entrained air.</p> <p>Pump or drive not securely mounted.</p> <p>Impeller clogged or damaged.</p>	<p>Reduce suction lift and/or friction losses in suction line. Record vacuum and pressure gauge readings and consult local representative or factory.</p> <p>Locate and eliminate source of air bubble.</p> <p>Secure mounting hardware.</p> <p>Clean out debris; replace damaged parts.</p>

Table 1. Trouble Shooting Chart (cont.)

TROUBLE	POSSIBLE CAUSE	PROBABLE REMEDY
BEARINGS RUN TOO HOT	Bearing temperature is high, but within limits. Low or incorrect lubricant. Suction and discharge lines not properly supported. Drive misaligned.	Check bearing temperature regularly to monitor any increase. Check for proper type and level of lubricant. Check piping installation for proper support. Align drive properly.

PREVENTIVE MAINTENANCE

Since pump applications are seldom identical, and pump wear is directly affected by such things as the abrasive qualities, pressure and temperature of the liquid being pumped, this section is intended only to provide general recommendations and practices for preventive maintenance. Regardless of the application however, following a routine preventive maintenance schedule will help assure trouble-free performance and long life from your Gorman-Rupp pump. For specific questions concerning your application, contact your Gorman-Rupp distributor or the Gorman-Rupp Company.

Record keeping is an essential component of a good preventive maintenance program. Changes in suction and discharge gauge readings (if so

equipped) between regularly scheduled inspections can indicate problems that can be corrected before system damage or catastrophic failure occurs. The appearance of wearing parts should also be documented at each inspection for comparison as well. Also, if records indicate that a certain part (such as the seal) fails at approximately the same duty cycle, the part can be checked and replaced before failure occurs, reducing unscheduled down time.

For new applications, a first inspection of wearing parts at 250 hours will give insight into the wear rate for your particular application. Subsequent inspections should be performed at the intervals shown on the chart below. Critical applications should be inspected more frequently.

Preventive Maintenance Schedule					
Item	Service Interval*				
	Daily	Weekly	Monthly	Semi-Annually	Annually
General Condition (Temperature, Unusual Noises or Vibrations, Cracks, Leaks, Loose Hardware, Etc.)	I				
Pump Performance (Gauges, Speed, Flow)	I				
Bearing Lubrication		I			R
Seal Lubrication (And Packing Adjustment, If So Equipped)		I			R
V-Belts (If So Equipped)			I		
Air Release Valve Plunger Rod (If So Equipped)			I	C	
Front Impeller Clearance (Wear Plate)				I	
Rear Impeller Clearance (Seal Plate)				I	
Check Valve					I
Pressure Relief Valve (If So Equipped)					C
Pump and Driver Alignment					I
Shaft Deflection					I
Bearings					I
Bearing Housing					I
Piping					I
Driver Lubrication – See Mfgr’s Literature					I

Legend:
 I = Inspect, Clean, Adjust, Repair or Replace as Necessary
 C = Clean
 R = Replace

* Service interval based on an intermittent duty cycle equal to approximately 4000 hours annually. Adjust schedule as required for lower or higher duty cycles or extreme operating conditions.

PUMP MAINTENANCE AND REPAIR - SECTION E

MAINTENANCE AND REPAIR OF THE WEARING PARTS OF THE PUMP WILL MAINTAIN PEAK OPERATING PERFORMANCE.

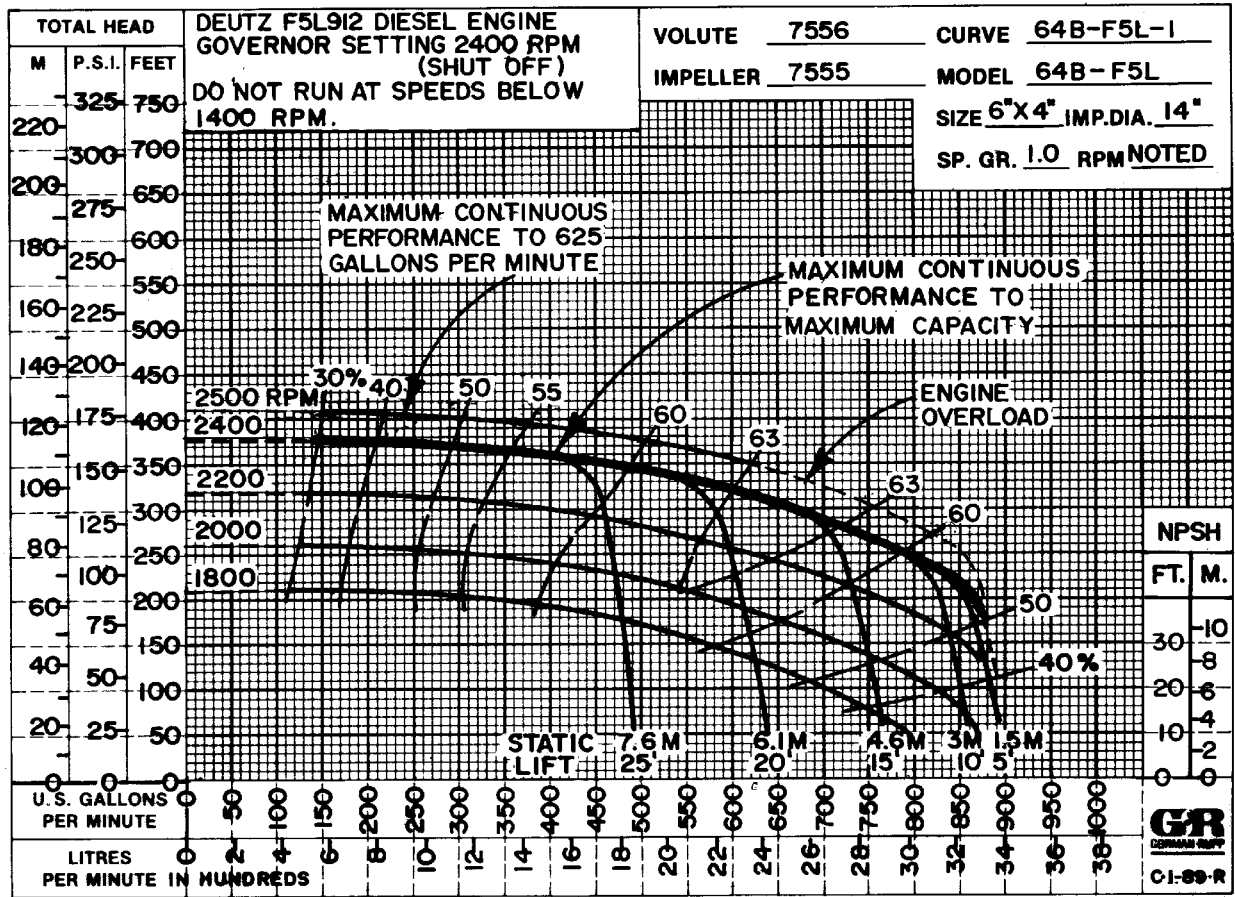

* STANDARD PERFORMANCE FOR PUMP MODEL 64B2--F5L

* Based on 70_ F (21_ C) clear water at sea level with minimum suction lift. Since pump installations are seldom identical, your performance may be difference due to such factors as viscosity, specific gravity, elevation, temperature, and impeller trim.

If your pump serial number is followed by an "N", your pump is **NOT** a standard production model. Contact the Gorman-Rupp Company to verify performance or part numbers.



WARNING!

Never tamper with the governor to gain more power. The governor establishes safe operating limits that should not be exceeded. The maximum continuous operating speed for this pump is 2400 RPM.

SECTION DRAWING

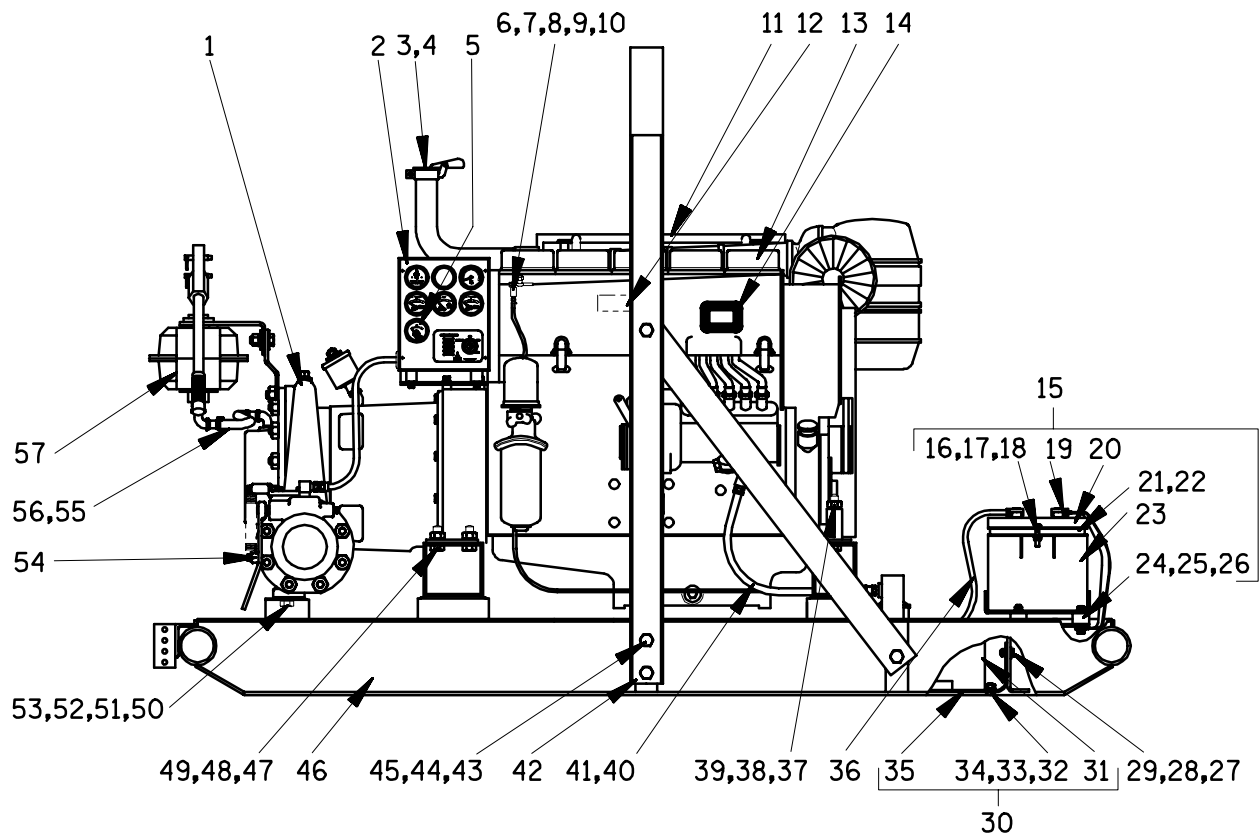

Figure 1. Pump Model 64B2-F5L

SECTION DRAWING

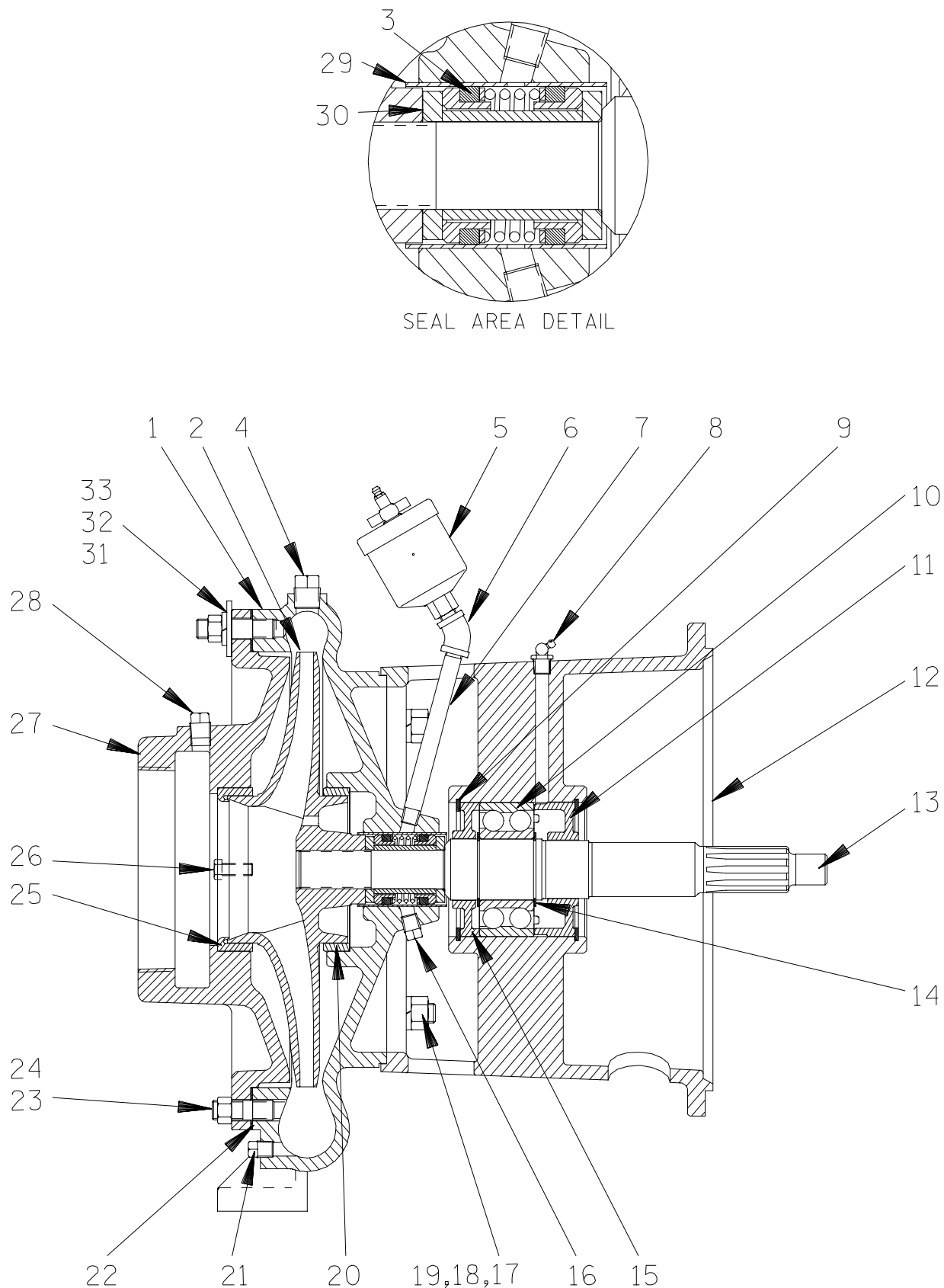

Figure 2. Pump End Assembly 64B2--(F5L)

PARTS LIST
Pump End Assembly 64B2 – (F5L)

ITEM NO.	PART NAME	PART NUMBER	MAT'L CODE	QTY	ITEM NO.	PART NAME	PART NUMBER	MAT'L CODE	QTY
1	PUMP CASING	7556	10030	1	23	STUD	C1008	15991	14
2*	IMPELLER	7555	10010	1	24	HEX NUT	D10	15991	16
3*	SEAL ASSY	GS1250	---	1	25*	WEAR RING	64H5	14000	1
4	PIPE PLUG	P08	15079	1	26	HEX HD CAPSCREW	B0604	15991	2
5	GREASE CUP	S1509	---	1	27	SUCTION HEAD	8569	10010	1
6	PIPE ELBOW	AG04	11999	1	28	ACCESSORY PLUG	P06	15079	1
7	HEAVY PIPE NIPPLE	THA0424	15079	1	29*	SEAL LINER	2205A	14080	REF
8	LUBE FITTING	S194	---	1	30*	IMP ADJ SHIM SET	37J	17090	REF
9	BRG RETAINING RING	S1165	---	2	31	STUD	C1010	15991	2
10*	BALL BEARING	23421-461	---	1	32	FLAT WASHER	K10	15991	2
11	BEARING RETAINER	7019	10010	1	33	LOCKWASHER	J10	15991	2
12	INTERMEDIATE	7013	10010	1		NOT SHOWN:			
13*	IMPELLER SHAFT	8396B	16040	1		DRIVE ASSY	44162-048	---	1
14	BRG RETAINING RING	S1164	---	2		NAME PLATE	2613R	13990	1
15	BEARING RETAINER	7018	10010	1		DRIVE SCREW	BM#04-03	17000	2
16	PIPE PLUG	P04	15079	1		STRAINER	S1529	---	1
17	STUD	C1009	15991	4		PIPE PLUG	P08	15079	1
18	HEX NUT	D10	15991	4		G-R DECAL	GR-03	---	1
19	LOCKWASHER	J10	15991	4		SUCTION STICKER	6588AG	---	1
20*	BALANCE RING	64H6	14000	1		GREASE CUP INSTR	6588BD	---	1
21	CASING DRAIN PLUG	P04	15079	1		DISCHARGE STICKER	6588BJ	---	1
22*	SUCTION HEAD GSKT	7557G	18000	1		INSTRUCTION TAG	38817-085	---	1

* INDICATES PARTS RECOMMENDED FOR STOCK

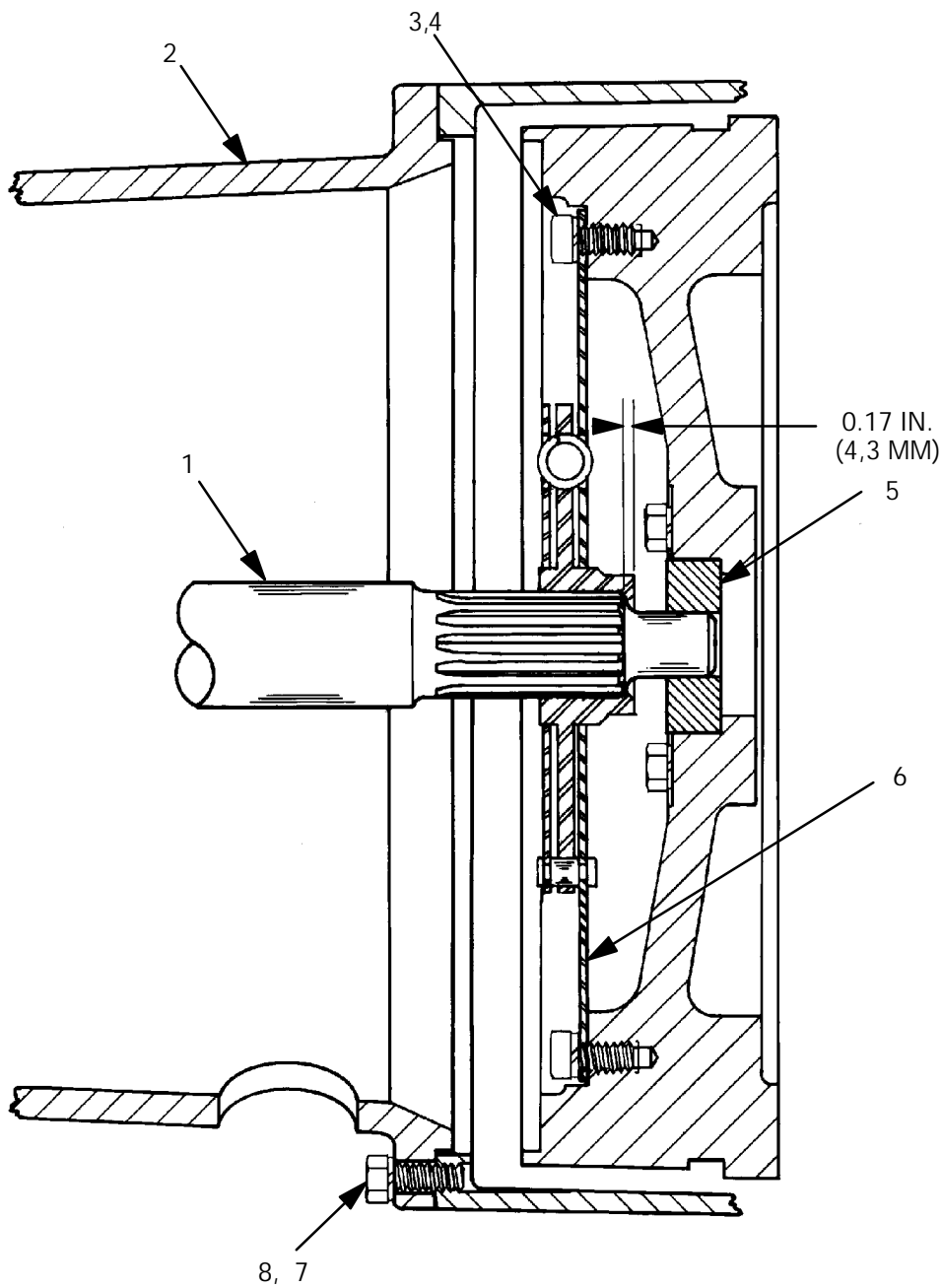

Figure 3. Drive Assembly For 64B2-(F5L)

PARTS LIST

ITEM NO.	PART NAME	PART NUMBER	MAT'L CODE	QTY
1	IMPELLER SHAFT	8396B	16040	REF
2	INTERMEDIATE	7013	10010	REF
3	SOCKET HD CAPSCREW	22644-215	---	8
4	LOCKWASHER	21171-511	---	8
5	PILOT BUSHING	8312A	15010	1
6	DRIVE PLATE ASSY	24521-165	---	1
7	LOCKWASHER	21171-511	---	12
8	HEX HD CAPSCREW	22645-164	---	12

PUMP AND SEAL DISASSEMBLY AND REASSEMBLY

Review all SAFETY information in Section A.

Follow the instructions on all tags, label and decals attached to the pump.

This pump requires little service due to its rugged, minimum-maintenance design. However, if it becomes necessary to inspect or replace the wearing parts, follow these instructions which are keyed to the sectional views (see Figures 1 and 2) and the accompanying parts lists.

As described on the following pages, this manual will alert personnel to known procedures which require special attention, to those which could damage equipment, and to those which could be dangerous to personnel. However, this manual cannot possibly anticipate and provide detailed precautions for every situation that might occur during maintenance of the unit. Therefore, it is the responsibility of the owner/maintenance personnel to ensure that **only** safe, established maintenance procedures are used, and that any procedures not addressed in this manual are performed **only** after establishing that neither personal safety nor pump integrity are compromised by such practices.

See the accompanying literature for Installation, Operation and Maintenance of the Discharge Check Valve and the Hand Primer Assembly.

Before attempting to service the pump, switch off the engine ignition and disconnect the positive battery cable to ensure that the pump will remain inoperative. Close all valves in the suction and discharge lines.

For engine disassembly and repair, consult the literature supplied with the engine, or contact your local Deutz engine representative.



Before attempting to open or service the pump:

1. Familiarize yourself with this manual.

2. Switch off the engine ignition and disconnect the positive battery cable to ensure that the pump will remain inoperative.
3. Allow the pump to completely cool if overheated.
4. Check the temperature before opening any covers, plates, or plugs.
5. Close the suction and discharge valves.
6. Vent the pump slowly and cautiously.
7. Drain the pump.



Use lifting and moving equipment in good repair and with adequate capacity to prevent injuries to personnel or damage to equipment. Suction and discharge hoses and piping must be removed from the pump before lifting.

Suction Head Removal

(Figure 2)

Remove the suction and discharge piping. Before attempting to service the pump, remove the pump casing drain plug (21) and drain the pump. Clean and reinstall the drain plug.

Remove the hardware securing the hand primer assembly (57, Figure 1) to the pump casing.

NOTE

See the accompanying literature for maintenance and repair of the hand primer assembly.

Remove the hardware (24) and use the jacking screws (26) to force the suction head (27) out of the pump casing. Turn the screws evenly to prevent binding. Remove the suction head gasket (22).

Inspect the wear ring (25) for excessive wear or damage. The wear ring is secured in the suction head by a press fit. If replacement is required, press the wear ring from the suction head.

Separating Pump And Intermediate From Engine

(Figure 2)

To service the impeller (2), seal assembly (3) or bearing (10), the pump end must be separated from the base and engine. See Figure 1, and remove the hardware (50, 51, 52 and 53) securing the pump casing to the base (46).

NOTE

Disconnect the low discharge pressure piping from the discharge check valve or, if desired, disengage the hardware securing the discharge check valve assembly (54, Figure 1) and separate the check valve from the pump casing.

Support the pump casing and intermediate using a suitable hoist and sling, and remove the hardware (7 and 8, Figure 3) securing the intermediate to the engine bellhousing. Separate the assemblies by pulling the intermediate straight away from the engine. As the assemblies separate, the impeller shaft (13) will disengage from the drive plate assembly (6, Figure 3).

Tie and tag any leveling shims used under the pump casing mounting feet to ease reassembly.

(Figure 3)

It is not necessary to remove the drive plate assembly (6) from the engine flywheel unless the assembly or the pilot bushing (5) must be replaced. To remove the drive plate assembly, disengage the hardware (3 and 4).

Inspect the pilot bushing and, if replacement is required, use a suitable puller to remove it from the engine flywheel.

Impeller Removal

(Figure 2)

Before removing the impeller, turn the cross arm on the automatic lubricating grease cup (5) clockwise until it rests against the cover (see Figure 5). This will prevent the grease in the cup from escaping when the impeller is removed.

To remove the impeller (2), reach through the discharge port and tightly wedge a soft metal rod or a block of wood between the vanes of the impeller.

Turn the splined end of the shaft in a counter-clockwise direction (when facing the shaft). **Be careful** not to damage the impeller or shaft splines. Use caution when removing the impeller; tension on the seal spring will be released when the impeller is removed.

NOTE

*An alternate method of removing the impeller without separating the pump from the engine is to remove the suction head as previously described and use a strap wrench around the front of the impeller to remove it from the shaft. **Be careful** not to damage the impeller.*

Remove the impeller adjusting shims (30). For ease of reassembly, tie and tag the shims or measure and record their thickness.

Inspect the balance ring (20) for excessive wear or damage. The balance ring is secured in the pump casing by a press fit. If replacement is required, use a suitable puller to remove it, or carefully cut it using a chisel. **Be careful** not to damage the casing bore.

Seal Removal and Disassembly

(Figure 2)

Make certain that the cross arm on the grease cup has been turned down against the cover before removing the seal assembly.

Carefully remove the rotating elements, stationary seats, packing rings, seal spring, and spacer sleeve from the pump casing. Use two stiff wires with hooked ends if necessary.

Inspect the seal liner (29) for wear or grooves that could cause leakage or damage to the seal rings. The seal liner is secured by a press fit into the pump casing (1) and does not normally require replacement. If replacement is required, see **Seal Reassembly And Installation**.

If no further disassembly is required, refer to **Seal Reassembly And Installation**.

Shaft And Bearing Removal And Disassembly

(Figure 2)

When the pump is properly operated and maintained, the shaft and bearing should not require disassembly. Disassemble the shaft and bearing **only** when there is evidence of wear or damage.

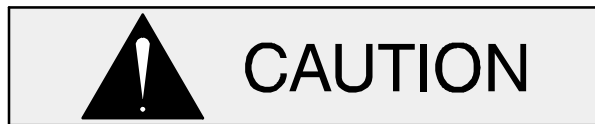

Shaft and bearing disassembly in the field is not recommended. These operations should be performed only in a properly-equipped shop by qualified personnel.

After separating the intermediate from the engine and removing the impeller and seal, remove the grease cup and hardware (5, 6, and 7). Remove the hardware (18 and 19) and separate the pump casing from the intermediate (12).

Remove the retaining ring (9) closest to the impeller end of the shaft from the intermediate (12).

NOTE

There are no provisions for draining the grease from the intermediate cavity. Place a drip pan under the intermediate before removing the shaft and bearing.

Place a block of wood against the drive end of the shaft, and tap the shaft, bearing retainer (15), and assembled bearing (10) from the bearing bore. **Be careful** not to damage the shaft.

Remove the bearing retainer (15) from the impeller shaft.

After removing the shaft and bearing, clean and inspect the bearing **in place** as follows.



To prevent damage during removal from the shaft, it is recommended that bearing be cleaned and inspected **in place**. It is **strongly** recommended that the bearing

be replaced **any** time the shaft and bearing are removed.

Clean the intermediate, shaft and all component parts (except the bearing) with a soft cloth soaked in cleaning solvent. Inspect the parts for wear or damage and replace as necessary.



Most cleaning solvents are toxic and flammable. Use them only in a well ventilated area free from excessive heat, sparks, and flame. Read and follow all precautions printed on solvent containers.

Clean the bearing thoroughly in **fresh** cleaning solvent. Dry the bearing with filtered compressed air and coat with light oil.



Bearings must be kept free of all dirt and foreign material. Failure to do so will greatly shorten bearing life. **Do not** spin dry bearings. This may scratch the balls or races and cause premature bearing failure.

Rotate the bearing by hand to check for roughness or binding and inspect the bearing balls. If rotation is rough or the bearing balls are discolored, replace the bearing.

The bearing tolerances provide a tight press fit onto the shaft and a snug slip fit into the intermediate. Replace the bearing, shaft, or intermediate if the proper bearing fit is not achieved.

If bearing replacement is required, remove the bearing retaining ring (14) closest to the impeller end of the shaft and press the bearing from the shaft. It is not necessary to remove the outboard bearing retaining ring (14) from the shaft unless replacement is required.

It is not necessary to remove the outboard bearing retainer (11) unless replacement is required. To remove the retainer, use snap ring pliers to remove the retaining ring (9), and press the retainer from the intermediate bore.

Shaft and Bearing Reassembly and Installation

Clean and inspect the bearing as indicated in **Shaft and Bearing Removal and Disassembly**.

Inspect the shaft for distortion, nicks or scratches or thread damage on the impeller end. Dress small nicks and burrs with a fine file or emery cloth. Replace the shaft if defective.

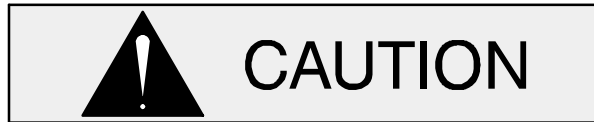

To prevent damage during removal from the shaft, it is recommended that bearing be cleaned and inspected **in place**. It is **strongly** recommended that the bearing be replaced **any** time the shaft and bearing are removed.

The bearing may be heated to ease installation. An induction heater, hot oil bath, electric oven, or hot plate may be used to heat the bearing. The bearing should **never** be heated with a direct flame or directly on a hot plate.

NOTE

If a hot oil bath is used to heat the bearing, both the

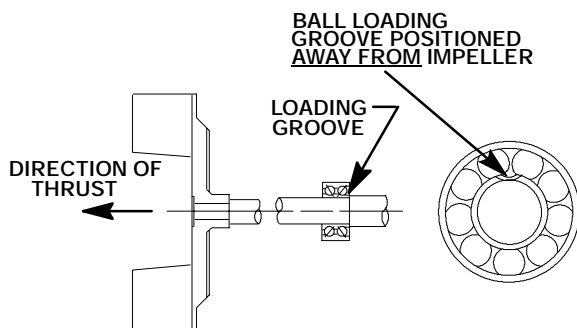

INSTALLATION OF NEW DEPARTURE OR BCA/FEDERAL MOGAL 5300W SERIES BEARINGS (OPEN OR ENCLOSED IMPELLERS)

*oil and the container must be **absolutely** clean. If the oil has been previously used, it must be **thoroughly** filtered.*

If removed, install the bearing retaining ring (14) closest to the drive end of the shaft in the groove in the shaft.

Heat the bearing to a uniform temperature **no higher than 250_F (120_C)**, and slide the it onto the shaft until fully seated against the retaining ring. This should be done quickly, in one continuous motion, to prevent the bearings from cooling and sticking on the shaft.



Use caution when handling hot bearings to prevent burns.

NOTE

Position the bearing (10) on the shaft as indicated by the following illustrations.

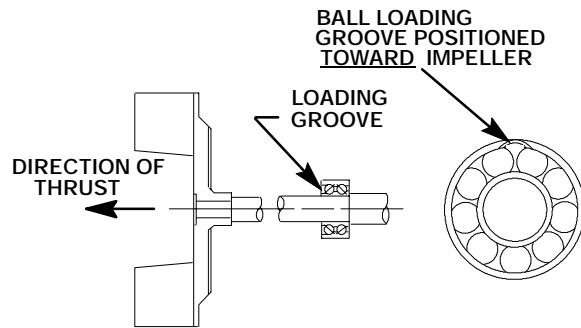

INSTALLATION OF MRC/SKF 5300M OR FAFNIR 5300W SERIES BEARINGS (OPEN OR ENCLOSED IMPELLERS)

Figure 4. Bearing Installation

After the bearing has been installed and allowed to cool, check to ensure that it has not moved out of position in shrinking. If movement has occurred, use a suitably sized sleeve and a press to reposition the bearing.

If heating the bearing is not practical, use a suitably sized sleeve and an arbor (or hydraulic) press to install the bearing on the shaft.



When installing the bearing onto the shaft, **never** press or hit against the outer race, balls, or ball cage. Press **only** on the inner race.

After the bearing is installed on the shaft, pack the bearing by hand with No. 0 lithium base grease until the bearing balls are thoroughly lubricated. Secure the bearing on the shaft with the bearing retaining ring (14).

If removed, install the retaining ring (9) and bearing retainer (11) in the drive side of the bearing bore. **Be sure** the retainer is properly positioned with the slotted side toward the **inside** of the bearing cavity (see Figure 2).

Slide the shaft and assembled bearing into the intermediate bore from the impeller end until the bearing seats squarely against the bearing retainer.



When installing the shaft and bearing into the bearing bore, push against the outer race. **Never** hit the balls or ball cage.

Position the bearing retainer (15) against the bearing, and secure it with the inboard retaining ring (9). Check the shaft endplay.

NOTE

Impeller shaft endplay should be between .002 and .010 inch (0,05 to 0,25 mm). This endplay is designed into the intermediate, and no adjustment should be required.

Lubricate the bearing cavity as indicated in **LUBRICATION** at the end of this section.

Seal Reassembly and Installation

(Figures 2 and 5)

Clean the seal cavity and shaft with a cloth soaked in fresh cleaning solvent.



Most cleaning solvents are toxic and flammable. Use them only in a well ventilated area free from excessive heat, sparks, and flame. Read and follow all precautions printed on solvent containers.

The seal is not normally reused because wear patterns on the finished faces cannot be realigned during reassembly. This could result in premature failure. If necessary to reuse an old seal in an emergency, **carefully** wash all metallic parts in **fresh** cleaning solvent and allow to dry thoroughly.

Handle the seal parts with extreme care to prevent damage. Be careful not to contaminate precision finished faces; even fingerprints on the faces can shorten seal life. If necessary, clean the faces with a non-oil based solvent and a clean, lint-free tissue. Wipe **lightly** in a concentric pattern to avoid scratching the faces.

Inspect the seal components for wear, scoring, grooves, and other damage that might cause leakage. Clean and polish the seal spacer sleeve, or replace it if there are nicks or cuts on either end. If any components are worn, replace the complete seal; **never mix old and new seal parts.**

If a replacement seal is being used, remove it from the container and inspect the precision finished faces to ensure that they are free of any foreign matter.

To ease installation of the seal, lubricate the packing rings and seal liner with water or a very **small** amount of oil, and apply a drop of light lubricating oil on the finished faces. Assemble the seal as follows (see Figure 5).

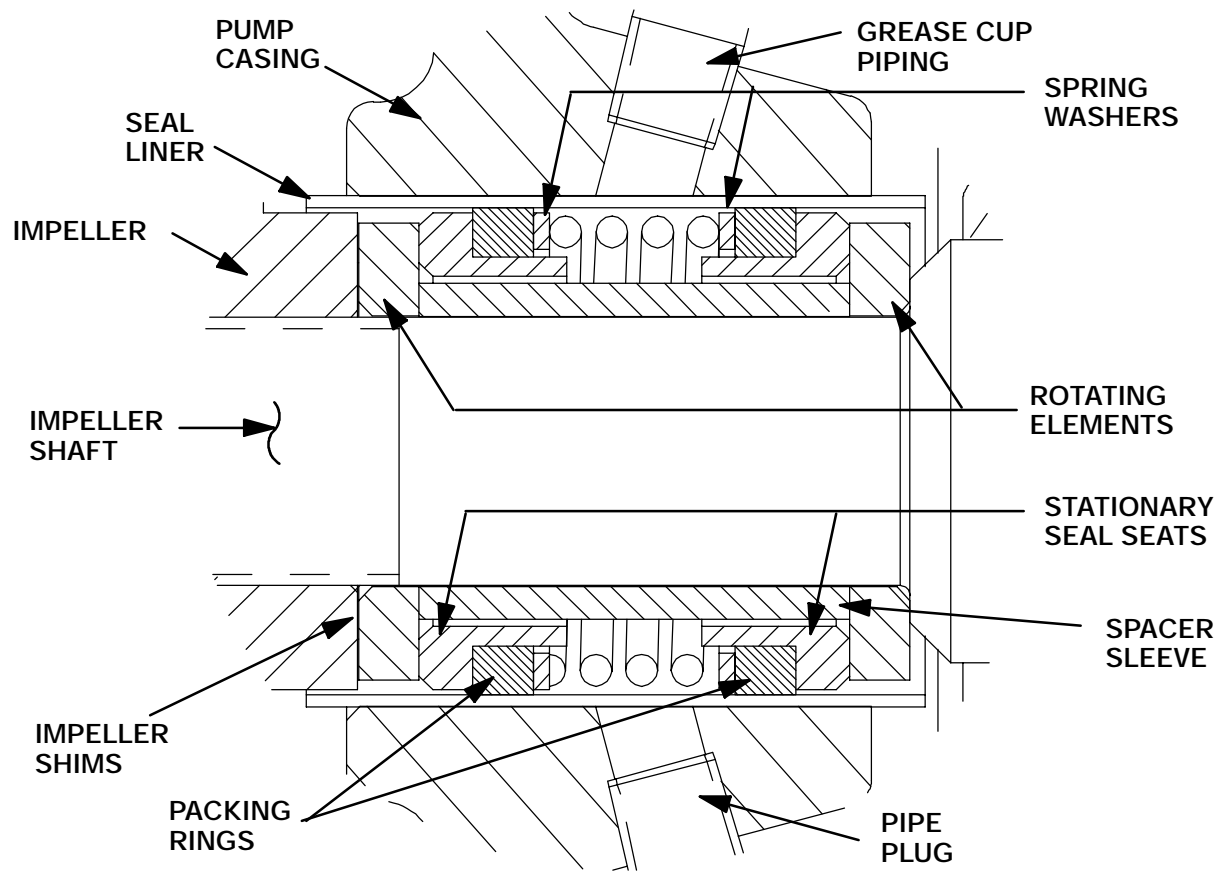

Figure 5. GS1250 Seal Assembly



This seal is not designed for operation at temperatures above 110_ F (43_C). Do not use at higher operating temperatures.

Inspect the pump casing, seal liner and the impeller shaft for burrs or sharp corners, and remove any that exist. Replace the seal liner (29) if wear or grooves exist which could cause leakage or damage to the seal packing rings.

To replace the seal liner, position the pump casing on the bed of an arbor (or hydraulic) press and use a new seal liner to press the old liner out. After the new liner is properly installed, a 1/4-inch diameter hole must be drilled through it to permit the flow of lubricant to the seal assembly. **Be careful** not to damage the threads in the pump casing when drilling the hole. Deburr the hole from the inside of the seal liner after drilling.

If the balance ring (20) was removed, position the replacement ring in the casing bore with the cham-

fered end toward the bore shoulder. Press the ring into the casing until it seats squarely against the casing shoulder.

NOTE

*The balance ring **must** seat squarely in the casing bore; otherwise binding and/or excessive wear will occur as the shaft turns.*

Carefully position the pump casing over the shaft. **Be careful** not to damage the shaft threads. Secure the casing to the intermediate with the hardware (18 and 19).

Slide the inboard rotating element onto the shaft with the chamfered side facing the shaft shoulder.

Subassemble the inboard stationary seat, packing ring and spring washer. Press this subassembly into the lubricated seal liner. A push tube cut from a length of plastic pipe would aid this installation. The O.D. of the pipe should be approximately the same diameter as the O.D. of the seal spring.

Install the spacer sleeve and seal spring.

Subassemble the outboard stationary seat, packing ring and spring washer. Press this subassembly into the lubricated seal liner.

Install the outboard rotating element with chamfered side facing the impeller.

After the impeller has been installed, lubricate the seal as indicated in **LUBRICATION**.

Impeller Installation

(Figure 2)

Inspect the impeller, and replace it if cracked or badly worn. Install the same thickness of impeller shims (30) as previously removed, and screw the impeller onto the shaft until tight.

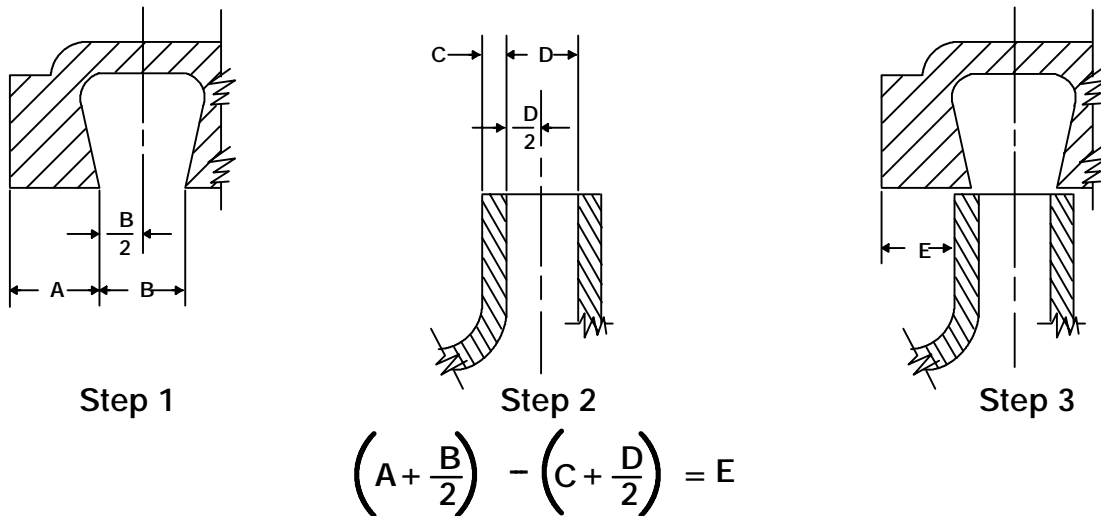

Figure 6. Centering Impeller Within Volute Scroll

NOTE

After the impeller has been properly positioned, check for free rotation. Correct any scraping binding before further reassembly.



The shaft and impeller threads **must** be completely clean before reinstalling the impeller. Even the slightest amount of dirt on the threads can cause the impeller to seize to the shaft, making future removal difficult or impossible without damage to the impeller or shaft.

For maximum pump efficiency, the impeller should be centered within the volute scroll.

To verify the impeller positioning, measure the pump casing and impeller as shown in Figure 6. Use these measurements to calculate the required impeller location (dimension E). Add or remove impeller adjusting shims until dimension E is obtained.

diameter of the pilot bushing (5), and press it into the flywheel until fully seated. Secure the drive plate assembly (6) to the flywheel with the hardware (3 and 4).

Securing Pump And Intermediate To Engine

(Figure 3)

If removed at disassembly, apply a thin coating of 'Never-Seez' or equivalent compound to the inside

Slide the shaft splines into the drive plate and position the intermediate (2) against the engine flywheel with the lubrication fitting (8, Figure 2) directed up. Secure the intermediate assembly to the engine bellhousing with the hardware (7 and 8).



Make certain that the drive plate and drive bushing are mounted in accordance with the dimension shown in Figure 3.

Install any leveling shims used under the pump casing mounting feet, and secure the pump casing to the base (46, Figure 1) with the mounting hardware (50, 51, 52 and 53, Figure 1).

Suction Head Installation

(Figure 2)

If removed at disassembly, press the wear ring (25) into the suction head (27) until it seats squarely against the bore shoulder.



The wear ring **must** seat squarely in the suction head or binding and/or excessive wear will result.

Install the suction head gasket (22), and secure the suction head to the pump casing with the nuts (24). Make sure the jacking screws (26) do not interfere with the suction head seating.

NOTE

Apply 'Loctite Thread Sealant' or equivalent compound to the studs before securing.

Final Pump Assembly

Reinstall the automatic lubricating grease cup and piping (5, 6 and 7, Figure 2).

Turn the shaft to make sure that the impeller is not binding or scraping. If it does, check the installation of the wear ring and balance ring, or remove adjusting shims until the impeller rotates freely when the pump is fully assembled.

Secure the hand primer (57, Figure 1) to the pump casing. If removed, secure the discharge check valve (54, Figure 1) to the pump casing discharge port. Connect any instrumentation lines or fittings removed from the check valve or hand primer.

Be sure the pump and intermediate are secure to the engine and the base.

Install the suction and discharge lines and open all valves. Make certain that all piping connections are tight, properly supported and secure.

Be sure the pump and engine have been properly lubricated, see **LUBRICATION**.

Before starting the pump, prime the pump using the hand-operated primer (see **OPERATION**, Section C).

LUBRICATION

Seal Assembly

(Figure 2)

Fill the grease cup (5) through the grease fitting with No. 2 lithium base grease until grease escapes from the relief hole. Turn the grease cup arm counterclockwise until it is at the top of the stem; this will release the spring to apply grease to the seal (see Figure 7).

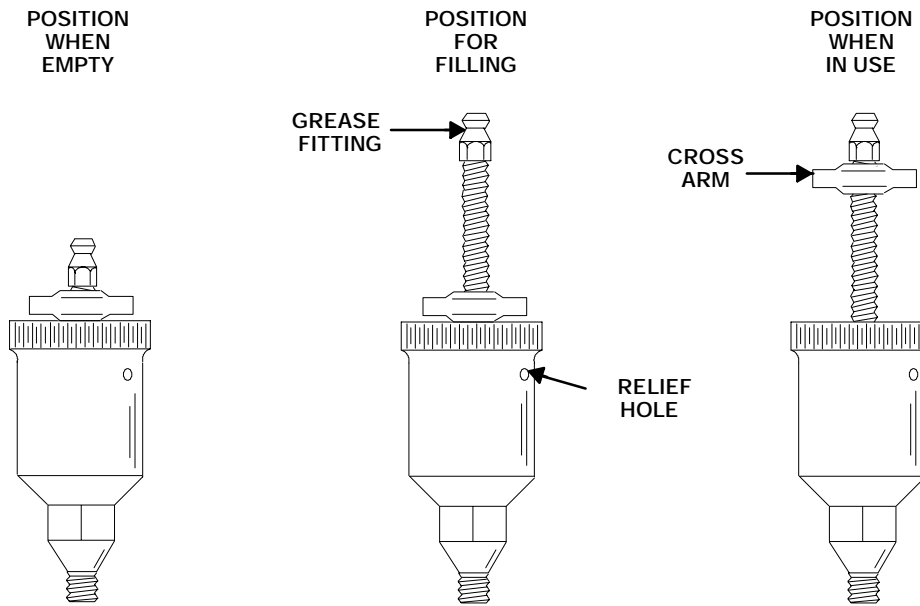

NOTE:
 When installing a new grease cup, lubricate the cup as indicated on the installation tag furnished with the grease cup.

Figure 7. Automatic Lubricating Grease Cup

Bearings

(Figure 2)

The intermediate was fully lubricated when shipped from the factory. Under normal conditions, add three shots of No. 0 lithium base grease from a grease gun through the grease fitting (8) after each 250 hours of operation or once each month, whichever comes first. **Do not** over-lubricate. Over-lubrication can cause the bearings to over-heat, resulting in premature bearing failure.



If grease is forced out around the shaft as new grease is added, the bearing cavity is full and should be disassembled and cleaned immediately.

There are no provisions in the bearing cavity to drain or flush the lubricant. The pump and interme-

di-ate must be disassembled to completely clean and maintain this cavity.

Under normal conditions, change the grease after each 5000 hours of operation, or at 12 month intervals, whichever comes first. Change the grease more frequently if the pump is operated continuously or installed in an environment where variable hot and cold temperatures are common.

When lubricating a dry (overhauled) intermediate, fill the cavity through the lubrication fitting with approximately 32 ounces (113 grams) of grease (approximately one-third full).

For cold weather operation, consult the factory or a lubricant supplier for the recommended grade of lubricant.

Engine

Consult the literature supplied with the engine, or contact your local Deutz engine representative.

**For U.S. and International Warranty Information,
Please Visit www.grpumps.com/warranty
or call:
U.S.: 419-755-1280
International: +1-419-755-1352**

**For Canadian Warranty Information,
Please Visit www.grcanada.com/warranty
or call:
519-631-2870**