

INSTALLATION, OPERATION, PARTS LIST,
AND MAINTENANCE MANUAL

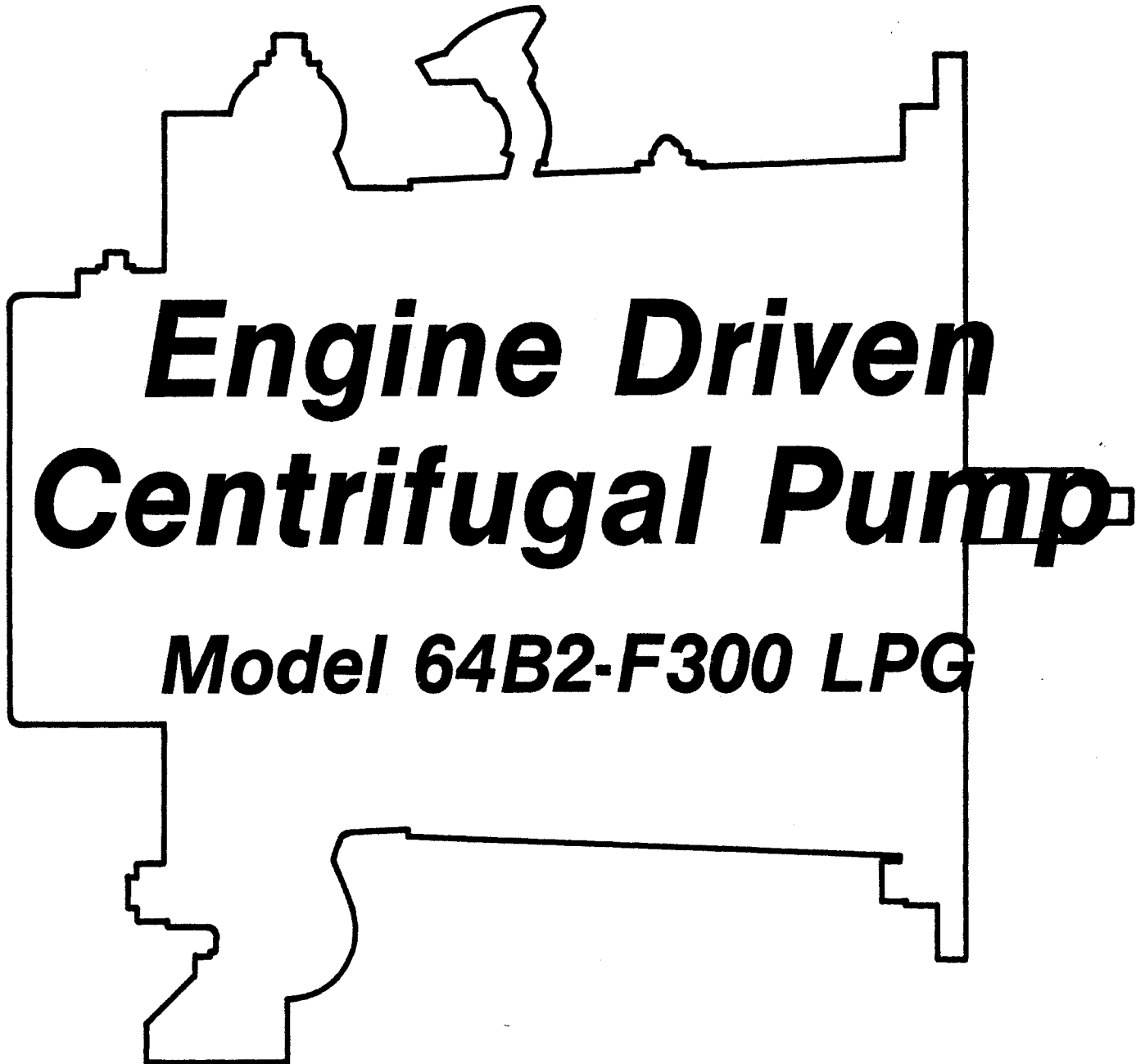

A C E

February 26, 1981



THE GORMAN-RUPP COMPANY • MANSFIELD, OHIO
GORMAN-RUPP OF CANADA LIMITED • ST. THOMAS, ONTARIO, CANADA Printed in U.S.A.

Copyright by the Gorman-Rupp Company



This Installation, Operation, and Maintenance Manual is designed to help you get the best performance and longest life from your Gorman-Rupp pump.

This pump is a 60 Series, semi-enclosed impeller model, with straight-in suction without a suction check valve. This pump is suitable for pumping liquids which do not contain large solids. For specific service, consult your Gorman-Rupp distributor or the Gorman-Rupp Company.

If there are any questions regarding the pump which are not covered in this manual or in other literature accompanying the unit, please contact your Gorman-Rupp distributor, or write:

The Gorman-Rupp Company	or	Gorman-Rupp of Canada Limited
P.O. Box 1217		70 Burwell Road
Mansfield, Ohio 44902		St. Thomas, Ontario N5P 3R7

For information or technical assistance on the engine drive, contact the engine manufacturer's local dealer or representative.

The following are used to alert maintenance personnel to procedures which require special attention, to those which could damage equipment, and to those which could be dangerous to personnel:

NOTE

Instructions to aid in installation, operation, or maintenance or which clarify a procedure.

CAUTION

Instructions which must be followed to avoid causing damage to the product or other equipment incidental to the installation. These describe the procedure required and the damage which could result from failure to follow the procedure.

WARNING

Instructions which must be followed to avoid causing injury or death to personnel. These describe the procedure required and the injury which could result from failure to follow the procedure.

TABLE OF CONTENTS

WARNINGS	Section A
INSTALLATION	Section B
OPERATION	Section C
TROUBLESHOOTING	Section D
MAINTENANCE AND REPAIR	Section E
WARRANTY	

WARNINGS

THESE WARNINGS APPLY TO 60 SERIES ENGINE DRIVEN PUMPS. REFER TO THE MANUAL ACCOMPANYING THE ENGINE BEFORE ATTEMPTING TO START THE ENGINE.

Before attempting to open or service the pump:

1. Familiarize yourself with this manual.
2. Disconnect the engine ignition to ensure that the pump will remain inoperative.
3. Allow the pump to cool if overheated.
4. Vent the pump slowly and cautiously.
5. Close the suction and discharge valves in the piping lines.
6. Check the temperature before opening any covers, plates, or plugs.
7. Drain the pump.

Do not attempt to pump any liquids for which this pump has not been designed.

Make certain that the pump and engine are securely attached before attempting to operate the pump.

Do not operate the pump against a closed discharge valve for long periods of time. This could bring the liquid to a boil, build pressure, and cause the pump to rupture or explode.



Overheated pumps can cause severe burns and injury. If overheating of the pump casing occurs:

1. Stop the pump immediately.
2. Allow the pump to cool.
3. Refer to instructions in this manual before restarting the pump.

Do not remove plates, covers, gauges, pipe plugs, or fittings from an overheated pump. Vapor pressure within the pump can cause parts being disengaged to be ejected with great force. Allow the pump to cool before servicing.

Do not operate an internal combustion engine in an explosive atmosphere. When operating internal combustion engines in an enclosed area, make certain that exhaust fumes are piped to the outside. These fumes contain carbon monoxide, a deadly gas that is colorless, tasteless, and odorless.

Fuel used by internal combustion engines presents an extreme explosion and fire hazard. Make certain that all fuel lines are securely connected and free of leaks. Never refuel a hot or running engine. Avoid overfilling the fuel tank. Always use the correct type of fuel.

Never tamper with the governor to gain more power. The governor establishes safe operating limits that should not be exceeded.

INSTALLATION

Since pump installations vary, this section is intended only to summarize recommended installation practice. If there are any questions concerning a specific installation, contact your Gorman-Rupp distributor or the Gorman-Rupp Company.

PREINSTALLATION INSPECTION

The pump assembly was inspected and tested before it was shipped from the factory. Before installation, inspect the pump for damage which may have occurred during shipment.

- a. Check the pump assembly for cracks, dents, damaged threads, and other obvious damage.
- b. Check for and tighten loose bolts, nuts, capscrews, and other attaching hardware. Since gaskets tend to shrink after drying, check for and tighten loose nuts and capscrews securing mating surfaces.
- c. Carefully read all tags, decals, and markings on the pump assembly, and perform all duties indicated. Note the direction of rotation indicated on the pump. Check that the pump shaft rotates in the required direction.

CAUTION

Only operate this pump in the direction indicated by the arrow on the pump body and on the accompanying decal. Otherwise, the impeller could become loosened from the shaft and seriously damage the pump.

- d. Check all lubricant levels and lubricate as necessary. Refer to the MAINTENANCE AND REPAIR section of this manual.

POSITIONING THE PUMP

Mounting

Locate the pump in an accessible place as close as practical to the liquid being pumped. Level mounting is essential for proper operation. It may be necessary to support or shim the pump for level operation.

Lifting

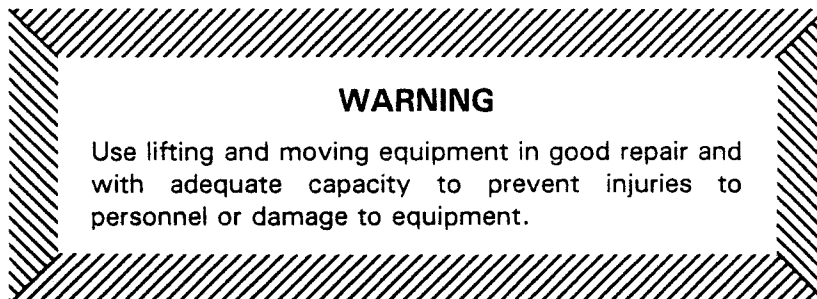

Make sure that hoists and other lifting equipment are of sufficient capacity to safely handle the pump assembly. If chains or cables are used in lifting, make certain that they are positioned so that they will not damage the pump, and so that the load will be balanced.

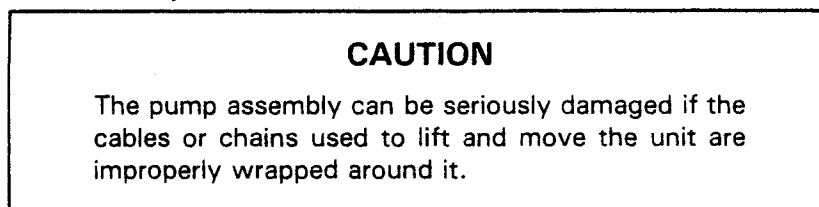

SUCTION AND DISCHARGE PIPING

Materials

Either pipe or hose may be used for suction and discharge lines, but hose used in suction lines must be the rigid-wall, reinforced type to prevent collapse under suction. Using pipe couplings in suction lines is not recommended.

Line Configuration

Keep suction and discharge lines as straight as possible to minimize friction losses. Make minimum use of elbows and fittings, which substantially increase friction loss. If elbows are necessary, use the long-radius type to minimize friction loss.

Connections To Pump

Before tightening a connecting flange, align it exactly with the pump port. Never pull a pipe line into place by tightening the flange bolts.

Lines near the pump must be independently supported to avoid strain on the pump which could cause excessive vibration, decreased bearing life, and increased shaft and seal wear. If hose-type lines are used, they should have adequate support to secure them when filled with liquid and under pressure.

Gauges

Most pumps are drilled and tapped for installing discharge pressure and vacuum suction gauges. If these gauges are desired for pumps that are not tapped, drill and tap the suction and discharge lines close to the pump before installing the lines.

SUCTION LINES

To avoid air pockets which could affect pump priming, the suction line must be as short and direct as possible. When operation involves a suction lift, the line must always slope upward to the pump from the source of the liquid being pumped; if the line slopes down to the pump at any point along the suction run, air pockets will be created.

Fittings

Suction lines should be the same size as the pump inlet. If reducers are used in suction lines, they should be the eccentric type, and should be installed with the flat part of the reducers uppermost to avoid creating air pockets. Valves are not normally used in suction lines, but if a valve is used, install it with the stem down or to either side to avoid air pockets.

Strainers

If a strainer is furnished with the pump, be certain to use it; any entrained solids which pass through a strainer furnished with the pump will also pass through the pump itself.

If a strainer is not furnished with the pump, but is installed by the pump user, make certain that the total area of the openings in the strainer is at least three or four times the cross section of the suction line, and that the openings will not permit passage of solids larger than the solids handling capability of the pump.

Sealing

Since even a slight leak will affect priming, head, and capacity, especially when operating with a high suction lift, all connections in the suction line should be sealed with pipe dope to ensure an airtight seal. In volatile and/or corrosive service, the pipe dope should be compatible with the liquid being pumped.

Suction Lines In Sumps

If a single suction line is installed in a sump, it should be positioned away from the wall of the sump at a distance equal to one and one-half times the diameter of the suction pipe.

If there is a liquid flow from an open pipe into the sump, the flow should be kept away from the suction inlet because the inflow will carry air down into the sump, and air entering the suction line will reduce pump efficiency.

If it is necessary to position inflow close to the suction inlet, install a baffle between the inflow and the suction inlet at a distance equal to one and one-half times the diameter of the suction pipe. The baffle will allow entrained air to escape from the liquid before it is drawn into the suction inlet.

If two suction lines are installed in a single sump, the flow paths may interact, reducing the efficiency of one or both pumps. To avoid this, position the suction inlets so that they are separated by a distance equal to three times the diameter of the suction pipe.

Suction Line Positioning

The depth of submergence of the suction line is critical to efficient pump operation. Figure 1 shows recommended minimum submergence vs. velocity.

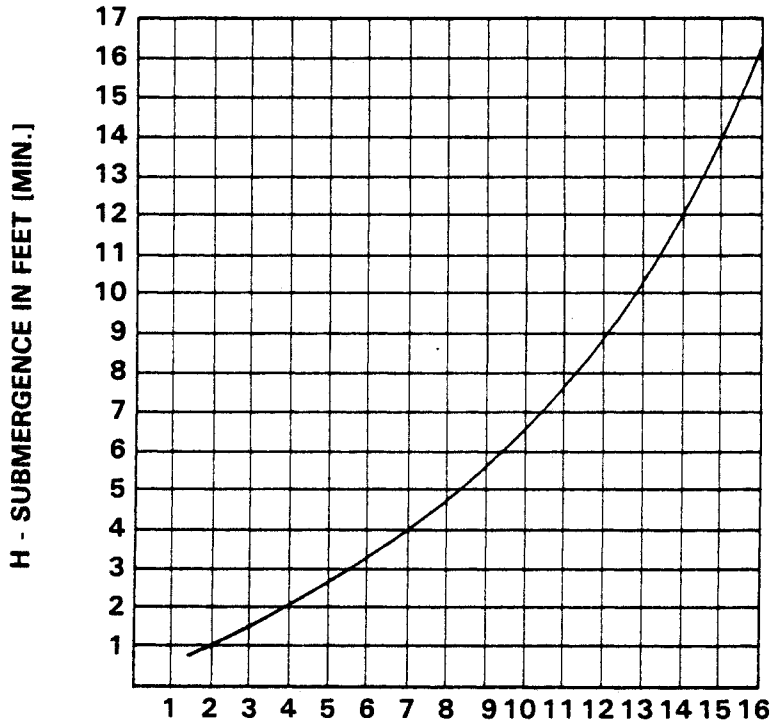

$$\text{VELOCITY IN FEET PER SEC.} = \frac{\text{QUAN. [G.P.M.] x .321}}{\text{AREA}} \text{ OR } \frac{\text{G.P.M. x .4085}}{D^2}$$

Figure 1. Recommended Minimum Suction Line Submergence Vs. Velocity

DISCHARGE LINES

Do not terminate the discharge line at a level lower than that of the liquid being pumped unless a siphon breaker is used in the line. Otherwise, a siphoning action causing damage to the pump could result.

Valves

If a throttling valve is desired in the discharge line, use a valve as large as the largest pipe in the line to minimize friction losses. Never install a throttling valve in a suction line.

A check valve in the discharge line is normally recommended, but is not necessary in low discharge head applications.

With high discharge heads, install a throttling valve and a check valve in the discharge line to protect the pump from excessive shock pressure and reverse rotation when it is stopped.

OPERATION

WARNING

Do not attempt to pump any liquids for which this pump has not been designed.

PRIMING

Install the pump and piping as described in INSTALLATION. Make sure that the piping connections are tight, and that the pump is securely mounted. Check that the pump is properly lubricated (see LUBRICATION in MAINTENANCE AND REPAIR).

This pump should never be operated unless there is liquid in the volute.

CAUTION

Never operate this pump unless the volute is filled with liquid. The pump will not prime when dry. Extended operation of a dry pump will destroy the seal assembly.

Add liquid to the volute housing:

1. When the pump is being put into service for the first time.
2. When the pump has not been used for a considerable length of time.
3. When the liquid in the volute housing has evaporated.

WARNING

After filling the volute housing, do not attempt to operate the pump unless all connecting piping is securely installed. Otherwise, liquid in the pump forced out under pressure could cause injury to personnel.



STARTING

Rotation

The correct direction of pump rotation is indicated by an arrow on the pump body, and on the accompanying decal. If the pump is operated in the wrong direction, the impeller could become loosened from the shaft and seriously damage the pump.

CAUTION

Only operate this pump in the direction indicated by the arrow on the pump body and on the accompanying decal. Otherwise, the impeller could become loosened from the shaft and seriously damage the pump.

Consult the operating manual furnished with the engine before attempting to start the engine.

Leakage

No leakage should be visible at pump mating surfaces, or at pump connections or fittings. Keep all line connections and fittings tight to maintain maximum pump efficiency.

Overheating

Overheating can occur if the valves in the suction or discharge lines are closed. Operating against closed valves could bring the liquid to a boil, build pressure, and cause the pump to rupture or explode. If overheating occurs, stop the pump and allow it to cool before servicing it. Refill the volute casing with cool liquid.

WARNING

Do not remove plates, covers, gauges, pipe plugs, or fittings from an overheated pump. Vapor pressure within the pump can cause parts being disengaged to be ejected with great force. Allow the pump to cool before servicing.

Strainer Check

If a suction strainer has been shipped with the pump or installed by the user, check the strainer regularly, and clean it as necessary. The strainer should also be checked if pump flow rate begins to drop.

Pump Vacuum Check

Since this pump does not have a suction check valve, the discharge line must be fitted with a check valve if a pump vacuum reading is to be taken.

With the pump inoperative, install a vacuum gauge in the system, using pipe dope on the threads. Block the suction line and start the pump. At operating speed the pump should pull a vacuum of 20 inches or more of mercury. If it does not, check for air leaks in the seal or gasket.

Open the suction line, and read the vacuum gauge with the pump primed and at operating speed. Shut off the pump, and read the gauge again to determine if the vacuum remains at the maximum developed by the pump. If the vacuum falls off rapidly, an air leak exists; check to make certain that the air leak is not from the vacuum gauge connection.

Stopping

After stopping the pump, disconnect the power source to ensure that the pump will remain inoperative.

In below freezing conditions, drain the pump to prevent damage from freezing. Also, clean out any solids by flushing with a hose. Operate the pump for approximately one minute; this will remove any remaining liquid that could freeze the pump rotating parts.

If the pump will be idle for more than a few hours, or if it has been pumping liquids containing a large amount of solids, drain the pump, and flush it thoroughly with clean water. To prevent large solids from clogging the drain port and preventing the pump from completely draining, operate the pump during the draining process. Clean out any remaining solids by flushing with a hose.

Bearing Temperature Check

Bearings normally run at higher than ambient temperatures because of heat generated by friction. Temperatures up to 160°F are considered normal for bearings, and they can operate safely to at least 180°F.

Checking bearing temperatures by hand is inaccurate. Bearing temperatures can be measured accurately by placing a contact-type thermometer against the housing. Record this temperature for future reference.

A sudden increase in bearing temperatures is a warning that the bearings are at the point of failing to operate properly. Make certain that the bearing lubricant is of the proper viscosity and at the correct level (see LUBRICATION in MAINTENANCE AND REPAIR). Bearing overheating can also be caused by shaft misalignment and/or excessive vibration.

When pumps are first started, the bearings may seem to run at temperatures above normal. Continued operation should bring the temperatures down to normal levels.



TROUBLESHOOTING

WARNING

Before attempting to open or service the pump:

1. Consult pump service manual.
2. Disconnect the power source to ensure that the pump will remain inoperative.
3. Allow pump to cool if overheated.
4. Close suction and discharge valves.
5. Drain pump.

Trouble	Possible Cause	Probable Remedy
PUMP FAILS TO PRIME	Air leak in suction line. Lining of suction hose collapsed. Leaking or worn seal or pump gasket. Suction lift or discharge head too high. Strainer clogged.	Correct leak. Replace suction hose. Check pump vacuum. Replace leaking or worn seal or gasket. Check piping installation and install bypass line if needed. See INSTALLATION. Check strainer and clean if necessary.
PUMP STOPS OR FAILS TO DELIVER RATED FLOW OR PRESSURE	Air leak in suction line. Suction intake not submerged at proper level or sump too small. Lining of suction hose collapsed. Impeller or other wearing parts worn or damaged. Impeller clogged. Pump speed too slow. Discharge head too high. Suction lift too high. Strainer clogged.	Correct leak. Check installation and correct as needed. Check submergence chart (Section B, page 4). Replace suction hose. Replace worn or damaged parts. Check that impeller is properly centered and rotates freely. Free impeller of debris. Check driver output; check belts or couplings for slippage. Install bypass line. Reduce suction lift. Check strainer and clean if necessary.

Trouble	Possible Cause	Probable Remedy
PUMP STOPS OR FAILS TO DELIVER RATED FLOW OR PRESSURE (cont)	Leaking or worn seal or pump gaskets.	Check pump vacuum. Replace leaking or worn seal or pump gaskets.
PUMP REQUIRES TOO MUCH POWER	Pump speed too high. Discharge head too low. Liquid solution too thick.	Check driver output; check that sheaves or couplings are correctly sized. Adjust discharge valve. Dilute if possible.
PUMP CLOGS FREQUENTLY	Discharge flow too slow.	Open discharge valve fully to increase flow rate, and run engine at maximum governed speed.
EXCESSIVE NOISE	Cavitation in pump. Pumping entrained air. Pump or drive not securely mounted. Impeller clogged or damaged.	Reduce suction lift and/or friction losses in suction line. Locate and eliminate source of air bubble. Secure mounting hardware. Clean out debris; replace damaged parts.
BEARINGS RUN TOO HOT	Bearing temperature is high, but within limits. Low or incorrect lubricant. Suction and discharge lines not properly supported. Drive misaligned.	Check bearing temperature frequently to monitor any increase. Check for proper type and level of lubricant. Check piping installation for proper support. Align drive properly.

Engine Driven Centrifugal Pump

Model 64B2-F300 LPG

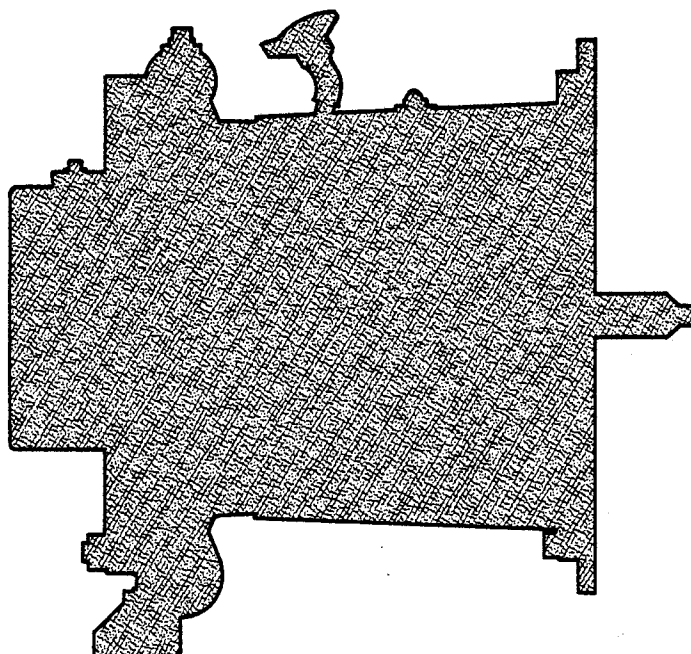

The only moving parts of this pump are the impeller, seal rotating elements, and the shaft. The balance ring, wear ring, impeller, and seal, which receive the most wear, are easily accessible and can be replaced without disturbing the piping. Maintenance and replacement of these four parts will maintain the peak operating efficiency of the pump.

SECTIONAL DRAWING

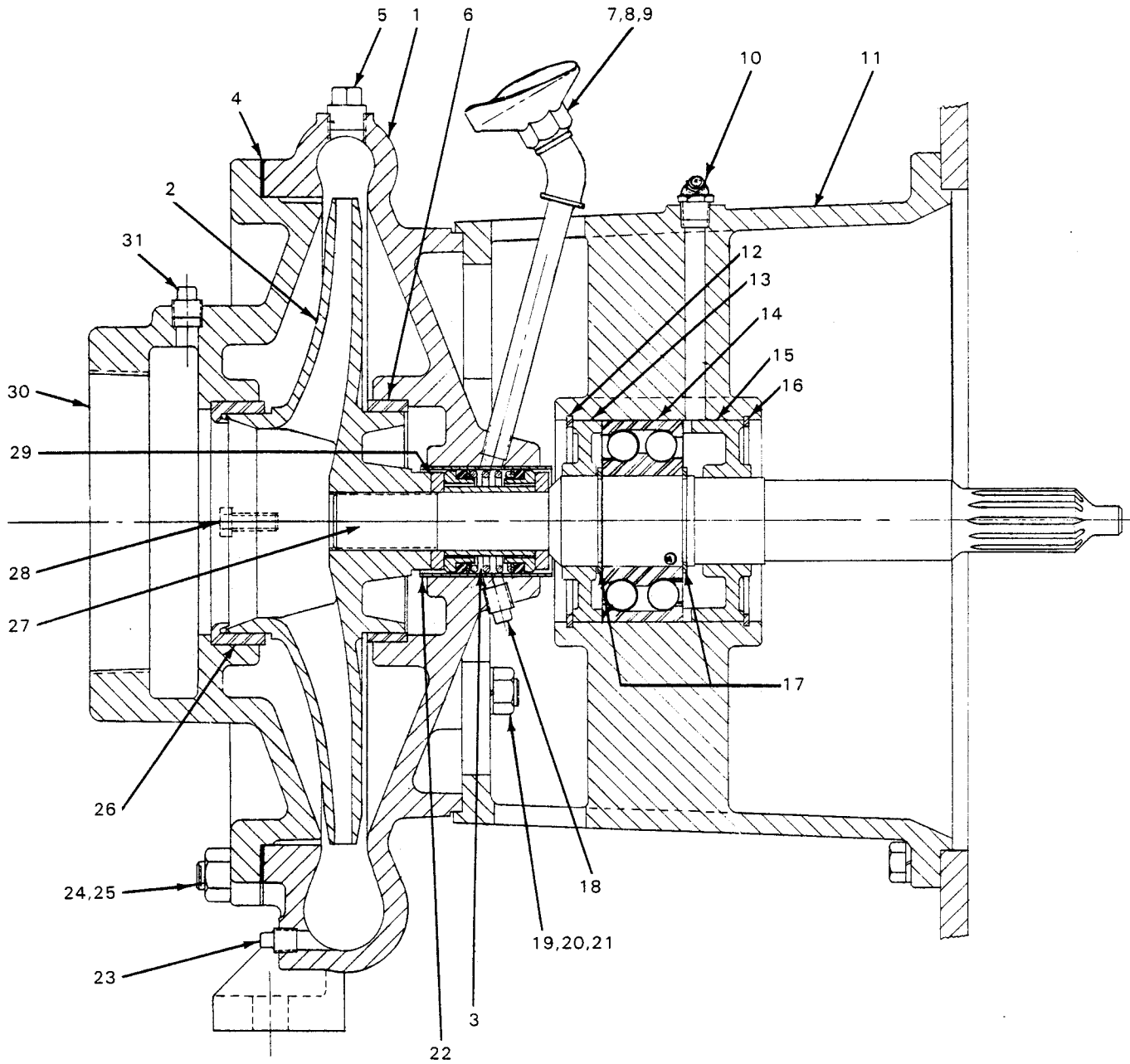

Figure 1. Pump Model 64B2-F300 LPG



PARTS LIST

PUMP MODEL 64B2-F300 LPG

(From S/N 727493 up)

ITEM NO.	PART NAME	PART NUMBER	MATL CODE	QTY	ITEM NO.	PART NAME	PART NUMBER	MATL CODE	QTY
1	VOLUTE HOUSING	7556	10120	1		CHECK VALVE BODY	4268	10010	1
2	★IMPELLER	7555	10010	1		HANDLE	5364	11000	1
3	★SEAL ASSEMBLY	GS-1250		1		BUSHING	11573	15030	1
4	★SUCTION HEAD GASKET	7557-G	18000	1		VALVE WEIGHT	11588	10010	1
5	PIPE PLUG	P-08	11990	2		CHECK VALVE GASKET	11591-G	18000	1
6	★BALANCE RING	64-H6	14000	1		CHECK VALVE MOLD	12390	24010	1
7	GREASE CUP	S-1509		1		HEX HEAD CAPSCREW	B-0604	15991	2
8	PIPE ELBOW	AG-04	11990	1		HEX HEAD CAPSCREW	B-0606	15991	2
9	PIPE NIPPLE	THA-0424	15070	1		HEX HEAD CAPSCREW	B-1009	15991	6
10	LUBRICATION FITTING	S-0194		1		STUD	C-1010	15991	2
11	INTERMEDIATE	7013	10010	1		HEX NUT	D-10	15991	8
12	RETAINING RING	S-1165		1		LOCKWASHER	J-06	15991	4
13	BEARING RETAINER	7018		1		FLAT WASHER	K-06	15991	2
14	BALL BEARING	S-1169		1		KEY	N-0207	15990	1
15	BEARING RETAINER	7019	10010	1		PIPE PLUG	P-04	11990	2
16	RETAINING RING	S-1165		1		PACKING RING	S-0378		2
17	RETAINING RING	S-1164		2		WOODRUFF KEY	AV-0404	15990	1
18	PIPE PLUG	P-04	11990	1		NYLOCK CAPSCREW	BT-0806	15991	1
19	STUD	C-1009	15991	4		ALLEN HEAD CAPSCREW	GA-0401	15990	2
20	HEX NUT	D-10	15991	4		ALLEN HEAD CAPSCREW	GA-0401½	15990	1
21	LOCKWASHER	J-10	15991	4		FLAT WASHER	KE-08	15991	1
22	★SEAL LINER	2205-A	14080	1		EP 78 EXHAUST PRIMER	GRP15-03		1
23	VOLUTE HOUSING DRAIN PLUG	P-04	11990	1		LEVEL HANDLE	1267-A	15990	1
24	HEX NUT	D-10	15991	16		PRIMING VALVE BODY	1629-A	10010	1
25	STUD	C-1008	15991	16		PRIMING VALVE	1630	10010	1
26	★SUCTION HEAD WEAR RING	64-H5	14000	1		EJECTOR BODY	1778	14000	1
27	IMPELLER SHAFT	8396-B	16040	1		EJECTOR BODY	1779	14000	1
28	HEX HEAD CAPSCREW	B-0604	15991	2		EXHAUST PRIMER DECAL	6588-AS	00000	1
29	★IMPELLER ADJUSTING SHIMS	37-J	17090	1		FLAT WASHER	K-05	15991	2
30	SUCTION HEAD	8569	10010	1		COTTER PIN	M-0506	15990	2
31	PIPE PLUG	P-06	11990	1		GAS COCK	S-02		1
NOT SHOWN:						SPRING WASHER	S-995		3
	NAME PLATE	2613-R	13990	1		PIPE NIPPLE	T-06	15070	1
	FC5PG ENGINE	204-K2		1		PIPE NIPPLE	T-16	15070	1
	MOUNTING HARDWARE					STREET ELBOW	RS-06	11990	1
	HEX HEAD CAPSCREW	B-1208		2		12V BATTERY BOX ASSEMBLY	GRP40-02		1
	HEX HEAD CAPSCREW	B-0804		2		GROUND CABLE ASSEMBLY	5795-AC	24040	1
	HEX HEAD CAPSCREW	B-0806		2		BATTERY FRAME	8355-B	24000	1
	HEX NUT	D-08		4		BATTERY BOX	8356-B	24000	1
	HEX NUT	D-12		2		HEX HEAD CAPSCREW	B-0604	15991	2
	LOCKWASHER	J-08		4		HEX HEAD CAPSCREW	B-0610	15991	2
	LOCKWASHER	J-12		2		HEX NUT	D-06	15991	4
	EXHAUST PRIMER TAG	6588-X	00000	1		LOCKWASHER	J-06	15991	4
	CABLE ASSEMBLY	6926-K	24040	1		FLAT WASHER	K-06	15991	4
	EXHAUST PIPE	11436	24000	1		BATTERY	S-1338		1
	BASE	12454	24000	1		INSTRUMENT PANEL ASSEMBLY	48312-002		1
	CONNECTOR	S-0551		2		FEMALE CONNECTOR	S-0577		1
	STRAINER	S-1529		1		TUBE FITTING	S-0634		1
	TUBBING	W-8192	14990	1		GROMMET	S-0756		1
	STREET ELBOW	AGS-04	11990	1		GROMMET	S-0807		1
	4265-A CHECK VALVE ASSEMBLY	GRP14-04A		1		SAFETY SWITCH	S-0812		1
	ADJUSTING SHIM SET	513-A	17090	3		HOSE END SWIVEL	S-1670		2
	SPRING BRACKET	3844	14000	1		HOSE	31411-012		1
	PACKING NUT	3847	14100	1		OPTIONAL:			
	SHAFT	3848	17100	1		HI-SPEED TRUCK ASSEMBLY	GRP30-26		1
	EXTENSION SPRING	3849	16030	1		SIDE PANEL SET	42142-022		1
	SPACER	3855	15070	2		HOURLMETER ASSEMBLY	48312-401		1
	WEIGHT ARM ASSEMBLY	4266	24000	1		TACHOMETER ASSEMBLY	48312-602		1

★ INDICATES PARTS RECOMMENDED FOR STOCK
Above Serial Numbers Do Not Apply To Pumps Made In Canada.

CANADIAN SERIAL NO. AND UP

SECTIONAL DRAWING

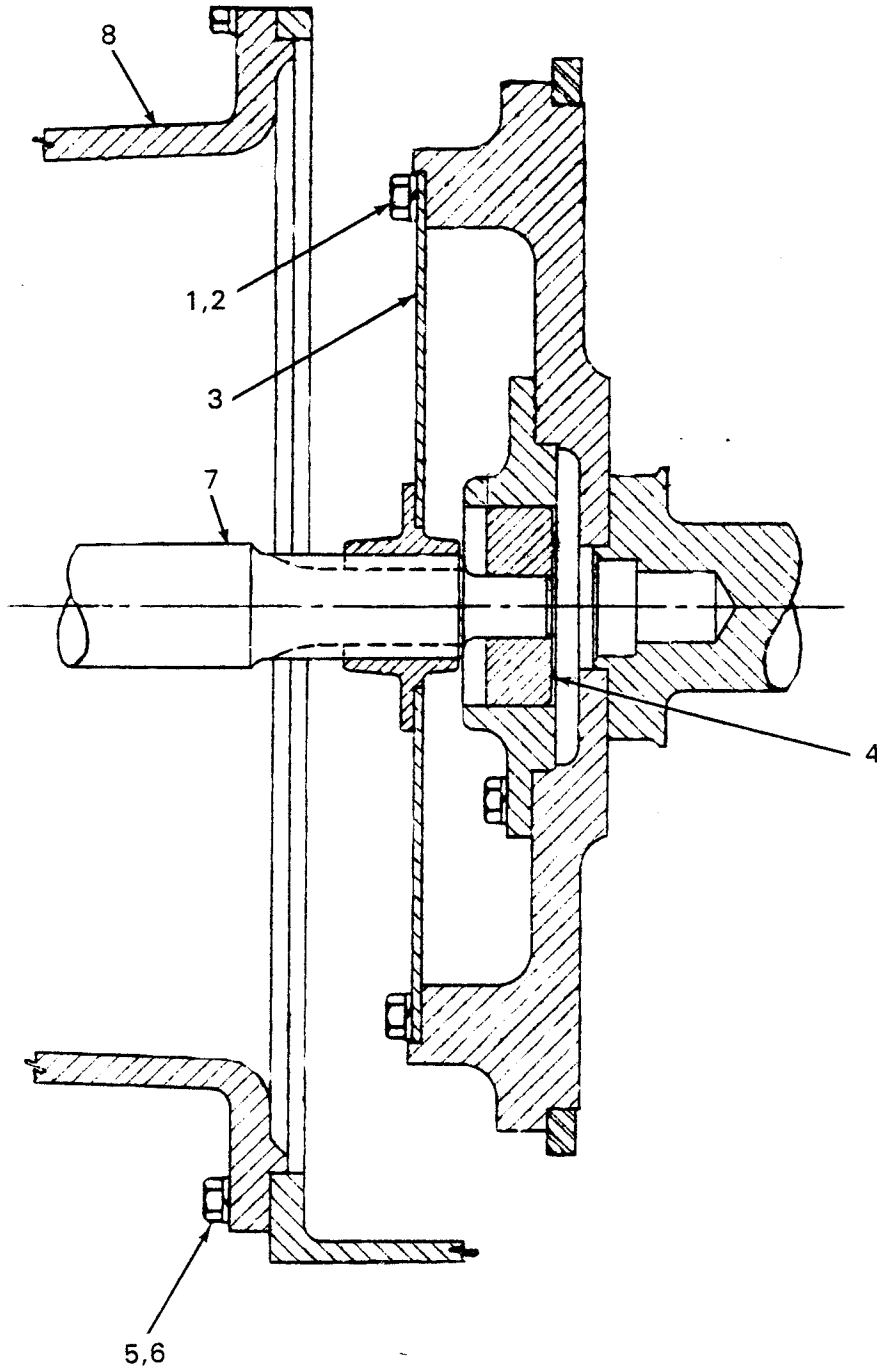

Figure 2. Pump Model 64B2-F300 LPG Drive Assembly

PARTS LIST

PUMP MODEL 64B2-F300 LPG DRIVE ASSEMBLY

ITEM NO.	PART NAME	PART NUMBER	MATERIAL CODE	QTY
1	HEX HEAD CAPSCREW	B-0603	15991	8
2	LOCKWASHER	J-06	15991	8
3	DRIVE PLATE ASSEMBLY	7409-A	24020	1
4	PILOT BUSHING	8312-A	15010	1
5	HEX HEAD CAPSCREW	B-0605	15991	12
6	LOCKWASHER	J-06	15991	12
7	IMPELLER SHAFT	8396-B	16040	1
8	INTERMEDIATE	7013-B	10010	1

ENGINE SEPARATION

If it is necessary to separate the pump from the engine, disengage the hex head capscrews (5, figure 2) securing the intermediate to the engines' flywheel housing, and separate the assemblies.

For access to the pilot bushing (4), disengage the hex head capscrews (1) securing the drive plate assembly (3) to the engine flywheel. Disengage the hex head capscrews securing the bushing retainer plate (furnished with the engine), and remove the pilot bushing.

Before reinstalling the pilot bushing on the shaft, apply Neverseez or equivalent lubricant to the inside diameter of the pilot bushing. Reinstall the pilot bushing so that it is inset 5/16" inside the bushing retainer. Reinstall the retainer.

CAUTION

If the pilot bushing is not properly positioned on the shaft, excessive wear and a preload condition could cause bearing failure.

PUMP AND SEAL DISASSEMBLY AND REASSEMBLY

This pump requires little service due to its rugged, minimum-maintenance design. If it becomes necessary to inspect or replace components in and adjacent to the rotating assembly, however, follow these instructions, which are keyed to the sectional views (see figures 1 and 2) and the accompanying parts lists.

Pump Disassembly



WARNING

Before attempting to open or service the pump:

1. Familiarize yourself with this manual.
2. Disconnect the power source to ensure that the pump will remain inoperative.
3. Allow the pump to cool if overheated.
4. Vent the pump slowly and cautiously.
5. Close the suction and discharge valves.
6. Check the temperature before opening any covers, plates, or plugs.
7. Drain the pump.

Disconnect the power source, making certain that it will remain inoperative while the pump is being serviced, and close all connecting valves.

Remove the volute housing drain plug (23, figure 1) to drain the pump. Clean and reinstall the plug after the pump has been drained.

For access to the impeller (2), and seal assembly (3) remove hex nuts (24) securing the suction head to the volute housing, and separate the assemblies.

To loosen the impeller, tap the vanes in the direction of pump rotation with a block of wood or a soft-face mallet or hammer. Use caution when unscrewing the impeller from the shaft; tension on the seal spring will be released as the impeller is removed.

Remove the impeller adjusting shims (29). For ease of reassembly, tag and tie the shims, or measure and record their thickness.

Seal Disassembly

Before removing the seal assembly, turn the cross arm on the seal grease cup (7) clockwise until it rests against the cover (see figure 4). This will prevent the grease in the cup from escaping after the seal is removed.

Using a stiff wire with a hooked end if necessary, remove the seal components, and the shaft sleeve. Remove the seal liner (22).

Clean the seal cavity and shaft with a soft cloth soaked in cleaning solvent.

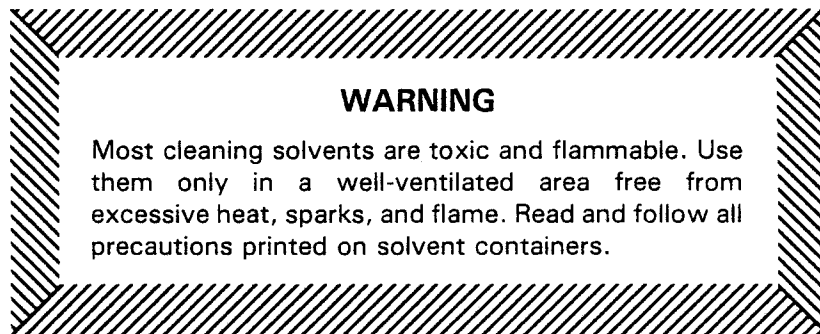
**Seal Reassembly**

The seal is not normally reused because of the high polish on its lapped faces, but if it is necessary to reuse the old seal, wash all metallic parts in cleaning solvent and dry thoroughly.

Inspect the seal components for wear, scoring, grooves, and other damage that might cause leakage. If any components are worn, replace the complete seal; never mix old and new seal parts.

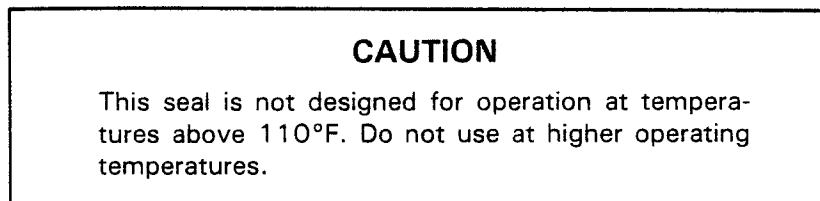

See figure 3 for the correct order of installation of seal components.

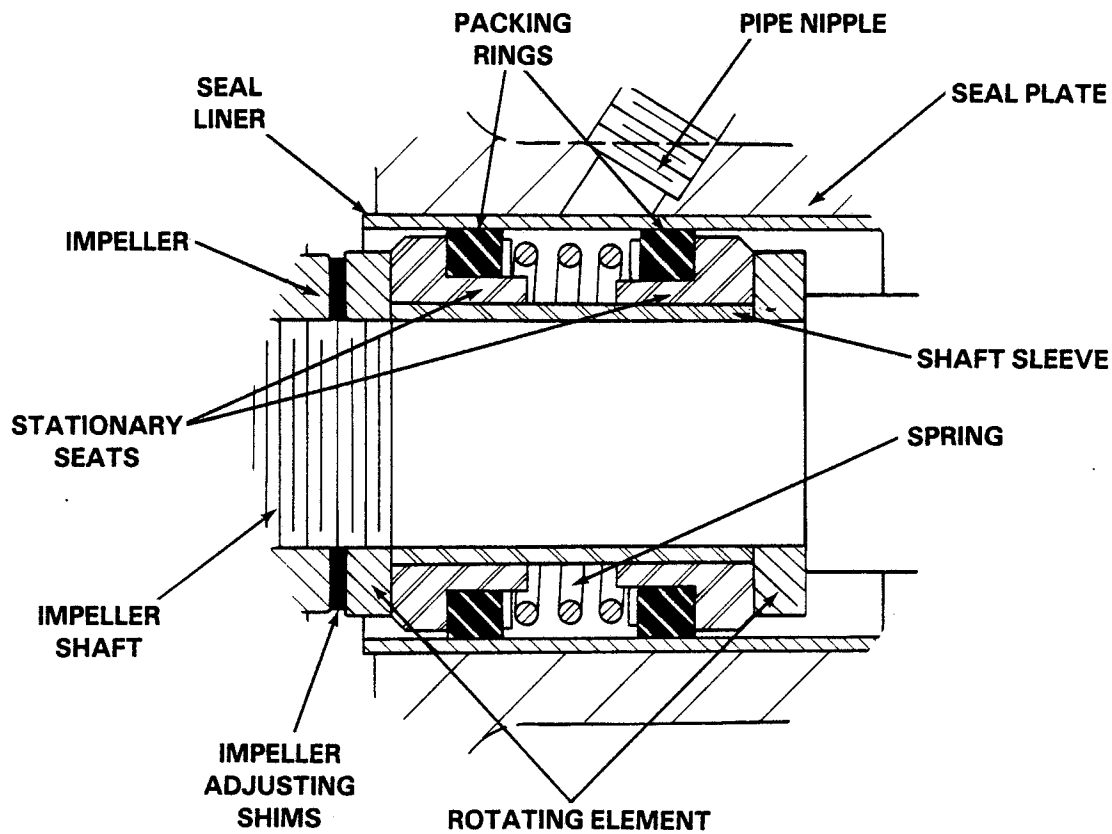

Figure 3. GS-1250 Seal Assembly

Inspect the seal liner, which is a press fit, and replace it if worn or scored. If the seal liner is replaced, a hole must be drilled in it after installation to permit the flow of lubricant from the grease cup to the seal assembly. Deburr the hole after drilling, and clean the seal liner.

Clean and polish the shaft sleeve, or replace it if there are nicks or cuts on the end.

Place a drop of light lubricating oil on the lapped faces of the seal, and lubricate the packing rings with soft grease or oil. Install the seal as a complete unit.

Pump Reassembly

Inspect balance ring (6), which is a press fit, and suction head wear ring (26) which is a press fit, and replace them if scored or worn.

For maximum pump efficiency the impeller must be centered with the volute scroll.

Reinstall the impeller adjusting shims. If the same number and thickness of shims are replaced as were removed, the impeller should be centered with the volute scroll.

Inspect the impeller, and replace it if cracked or badly worn. Install the impeller, making certain that all components of the seal are seated squarely on the shaft.

Replace the suction head gasket (4), and reassemble the suction head and the volute housing, securing the attaching hex nuts.

Turn the shaft to check that the impeller rotates freely. If it does not, remove impeller shims until the impeller rotates freely when the pump is completely assembled.

Add clean liquid to the volute, making certain that all piping is securely tightened before starting the pump.

LUBRICATION

Seal Assembly

Before starting the pump, fill the grease cup through the grease fitting with a good grade of No. 2 pressure gun grease until grease escapes from the relief hole. Turn the grease cup arm counterclockwise until it is at the top of the stem; this will release the spring to apply grease to the seal (see figure 4).

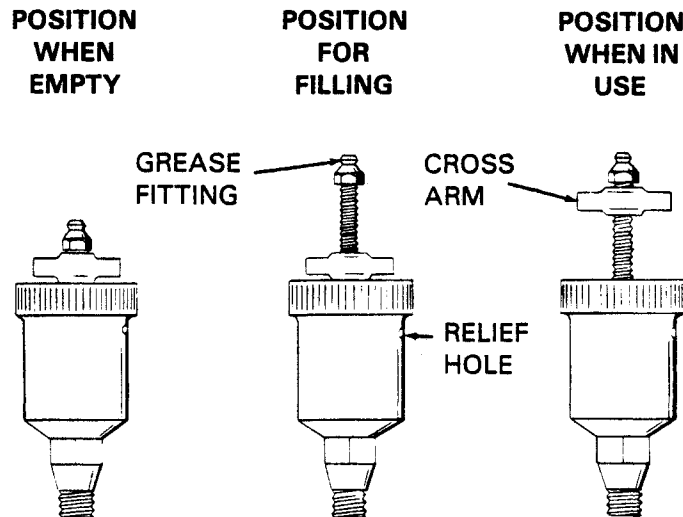

Figure 4. Automatic Lubricating Grease Cup

Bearings

When shipped from the factory, this pump contained sufficient grease to lubricate the bearings for approximately 5,000 operating hours. Do not lubricate sooner than required. Fill the cavity with $\frac{1}{4}$ lb. of No. 0 pressure gun grease through the intermediate lube fitting (10).

**For U.S. and International Warranty Information,
Please Visit www.grpumps.com/warranty
or call:
U.S.: 419-755-1280
International: +1-419-755-1352**

**For Canadian Warranty Information,
Please Visit www.grcanada.com/warranty
or call:
519-631-2870**