60SERIES

INSTALLATION, OPERATION, PARTS LIST, AND MAINTENANCE MANUAL



THE GORMAN-RUPP COMPANY • MANSFIELD, OHIO

GORMAN-RUPP OF CANADA LIMITED • ST. THOMAS, ONTARIO, CANADA

Printed in U.S.A.

Copyright by the Gorman-Rupp Company



The engine exhaust from this product contains chemicals known to the State of California to cause cancer, birth defects or other reproductive harm.

TABLE OF CONTENTS

INTRODUCTION	I-1
WARNINGS - SECTION A	A-1
INSTALLATION - SECTION B	B-1
PREINSTALLATION INSPECTION	B-1
POSITIONING PUMP	B-2
Lifting	B-2
Mounting	B-2
SUCTION AND DISCHARGE PIPING	B-2
Materials	B-2
Line Configuration	B-2
Connections to Pump	B-3
Gauges	B-3
SUCTION LINES	B-3
Fittings	B-3
Strainers	B-3
Sealing	B-4
Suction Lines In Sumps	B-4
Suction Line Positioning	B-4
DISCHARGE LINES	B-5
Siphoning	B-5
Valves	B-5
ALIGNMENT	B-6
OPERATION - SECTION C	C-1
PRIMING	C-1
Hand-Operated Priming Pump	C-2
STARTING	C-2
OPERATION	C-3
Leakage	C-3
Liquid Temperature And Overheating	C-3
Strainer Check	C-3
Pump Vacuum Check	C-3
STOPPING	C-4
Cold Weather Preservation	C-4
BEARING TEMPERATURE CHECK	C-4
PUMP TROUBLESHOOTING - SECTION D	D-1
PUMP MAINTENANCE AND REPAIR - SECTION E	E-1
PERFORMANCE CURVE	E-1
PUMP MODEL ASSY - PARTS LIST	E-3
PUMP END ASSY - PARTS LIST	E-5
DRIVE ASSY - PARTS LIST	E-7
PUMP AND SEAL DISASSEMBLY AND REASSEMBLY	E-8
Suction Head Removal	E-8
Impeller Disassembly	E-9
Seal Disassembly	E-9
Pump Disassembly	E-10
Separating Intermediate From Engine	E-10
Impeller Shaft And Bearing Disassembly	E-10
Impeller Shaft And Bearing Reassembly	E-11
Securing Intermediate To Pump	E-13
Pump Reassembly	E-13
Seal Reassembly	E-14
Impeller Reassembly And Adjustment	E-16
Suction Head Installation	E-16
Final Pump Reassembly	E-16
LUBRICATION	E-16
Seal Assembly	E-16

Bearings	E-17
Engine	E-17

INTRODUCTION

This Installation, Operation, and Maintenance Manual is designed to help you achieve the best performance and longest life from your Gorman-Rupp pump.

This pump is a 60 Series, centrifugal model with an enclosed impeller. This pump is designed for pumping liquids which contain large entrained solids. It is designed for straight-in suction without a suction check valve. The basic material of construction for wetted parts is gray iron with gray iron impeller, brass and gray iron wear rings and steel impeller shaft.

If there are any questions regarding the pump or its application which are not covered in this manual or in other literature accompanying this unit, please contact your Gorman-Rupp distributor, or write:

The Gorman-Rupp Company	or	Gorman-Rupp of Canada Limited
P.O. Box 1217		70 Burwell Road
Mansfield, Ohio 44901		St. Thomas, Ontario N5P 3R7

For information or technical assistance on the engine, contact the engine manufacturer's local dealer or representative.

The following are used to alert maintenance personnel to procedures which require special attention, to those which could damage equipment, and to those which could be dangerous to personnel:

NOTE

Instructions to aid in installation, operation, and maintenance or which clarify a procedure.

CAUTION

Instructions which must be followed to avoid causing damage to the product or other equipment incidental to the installation. These instructions describe the requirements and the possible damage which could result from failure to follow the procedures.

WARNING

```

////////////////////////////////////
//                               //
// These instructions must be followed to avoid causing in- //
// jury or death to personnel, and describe the procedure //
// required and the injury which could result from failure //
// to follow the procedure. //
//                               //
////////////////////////////////////

```

WARNINGS - SECTION A

THESE WARNINGS APPLY TO 60 SERIES ENGINE DRIVEN PUMPS. REFER TO THE MANUAL ACCOMPANYING THE ENGINE BEFORE ATTEMPTING TO BEGIN OPERATION.

WARNING

```

////////////////////////////////////
//
// Before attempting to open or service the pump:
//
// 1. Familiarize yourself with this manual.
// 2. Switch off the engine ignition key and remove the
// key to ensure that the pump will remain inopera-
// tive.
// 3. Allow the pump to cool if overheated.
// 4. Vent the pump slowly and cautiously.
// 5. Close the suction and discharge valves.
// 6. Check the temperature before opening any covers,
// plates, or plugs.
// 7. Drain the pump.
//
////////////////////////////////////

```

WARNING

```

////////////////////////////////////
//
// This pump is designed to pump liquids which contain
// large entrained solids. Do not attempt to pump
// volatile, corrosive, or flammable liquids which may dam-
// age the pump or endanger personnel as a result of pump
// failure.
//
////////////////////////////////////

```

WARNING

```

////////////////////////////////////
//
// After the pump has been installed, make certain that the
// pump and all piping are secure before operation.
//
////////////////////////////////////

```

WARNING

```

////////////////////////////////////
//
// Do not operate the pump without shields and/or guards in
// place over rotating parts. Exposed rotating parts can
// catch clothing, fingers, or tools, causing severe injury
// to personnel.
//
////////////////////////////////////

```

WARNINGS

WARNING

```

////////////////////////////////////
//
// Overheated pumps can cause severe burns and injury. If //
// overheating of the pump occurs: //
//
// 1. Stop the pump immediately. //
// 2. Allow the pump to cool. //
// 3. Refer to instructions in this manual before re- //
// starting the pump. //
//
////////////////////////////////////

```

WARNING

```

////////////////////////////////////
//
// Do not remove plates, covers, gauges, pipe plugs, or //
// fittings from an overheated pump. Vapor pressure within //
// the pump can cause parts being disengaged to be ejected //
// with great force. Allow the pump to cool before servic- //
// ing. //
//
////////////////////////////////////

```

WARNING

```

////////////////////////////////////
//
// Do not operate an internal combustion engine in an ex- //
// plosive atmosphere. When operating internal combustion //
// engines in an enclosed area, make certain that exhaust //
// fumes are piped to the outside. These fumes contain //
// carbon monoxide, a deadly gas that is colorless, //
// tasteless, and odorless. //
//
////////////////////////////////////

```

WARNING

```

////////////////////////////////////
//
// Fuel used by internal combustion engines presents an ex- //
// treme explosion and fire hazard. Make certain that all //
// fuel lines are securely connected and free of leaks. //
// Never refuel a hot or running engine. Avoid overfilling //
// the fuel tank. Always use the correct type of fuel. //
//
////////////////////////////////////

```

WARNINGS

WARNING

```
////////////////////////////////////  
//  
// Never tamper with the governor to gain more power. The //  
// governor establishes safe operating limits that should //  
// not be exceeded. The maximum continuous operating speed //  
// is 1600 RPM. //  
//  
////////////////////////////////////
```

INSTALLATION - SECTION B

Since pump installations are seldom identical, this section offers only general recommendations and practices required to inspect, position, and arrange the pump and piping.

Most of the information pertains to a standard **static lift application** where the pump is positioned above the free level of liquid to be pumped.

If installed in a **flooded suction application** where the liquid is supplied to the pump under pressure, some of the information such as mounting, line configuration, and priming must be tailored to the specific application. Since the pressure supplied to the pump is critical to performance and safety, **be sure to limit the incoming pressure to 50% of the maximum pressure developed by the pump.** (See Section E, Page 1). If the pump is fitted with a Gorman-Rupp double grease lubricated seal, the maximum incoming pressure must be reduced to 10 p.s.i..

For further assistance, contact your Gorman-Rupp distributor or the Gorman-Rupp Company.

PREINSTALLATION INSPECTION

The pump assembly was inspected and tested before shipment from the factory. Before installation, inspect the pump for damage which may have occurred during shipment. Check as follows:

- a. Inspect the pump and engine for cracks, dents, damaged threads, and other obvious damage.
- b. Check for and tighten loose bolts, nuts, capscrews, and other attaching hardware. Since gaskets tend to shrink after drying, check for and tighten loose nuts and capscrews securing mating surfaces.
- c. Carefully read all tags, decals, and markings on the pump assembly, and follow the instructions indicated.
- d. Check all lubricant levels and lubricate as necessary. Refer to LUBRICATION in the MAINTENANCE AND REPAIR section of this manual and perform duties as instructed.
- e. If the pump and engine have been stored for more than 12 months, some of the components or lubricants may have exceeded their maximum shelf life. **These must be inspected or replaced** to ensure maximum pump service.

If the maximum shelf life has been exceeded, or if anything appears to be abnormal, contact your Gorman-Rupp distributor or the factory to determine the repair or updating policy. **Do not** put the pump into service until appropriate action has been taken.

POSITIONING PUMP

Lifting

Use lifting equipment with a capacity of at least **13,750 pounds**. This pump weighs approximately **2,750 pounds**, not including the weight of accessories and the optional wheel kit. Customer installed equipment such as hoses **must** be removed before attempting to lift.

CAUTION

The pump assembly can be seriously damaged if the cables or chains used to lift and move the unit are improperly wrapped around the pump.

Mounting

Locate the pump in an accessible place as close as practical to the liquid being pumped. Level mounting is essential for proper operation. The pump may have to be supported or shimmed to provide for level operation or to eliminate vibration.

If the pump has been mounted on a moveable base, make certain the base is stationary by setting the brake and blocking the wheels before attempting to operate the pump.

SUCTION AND DISCHARGE PIPING

Materials

Either pipe or hose may be used for suction and discharge lines; however, the materials must be compatible with the liquid being pumped. If hose is used in suction lines, it must be the rigid-wall, reinforced type to prevent collapse under suction. Using piping couplings in suction lines is not recommended.

Line Configuration

Keep suction and discharge lines as straight as possible to minimize friction losses. Make minimum use of elbows and fittings, which substantially increase friction loss. If elbows are necessary, use the long-radius type to minimize friction loss.

Connections to Pump

Before tightening a connecting flange, align it exactly with the pump port. Never pull a pipe line into place by tightening the flange bolts and/or couplings.

Lines near the pump must be independently supported to avoid strain on the pump which could cause excessive vibration, decreased bearing life, and increased shaft and seal wear. If hose-type lines are used, they should have adequate support to secure them when filled with liquid and under pressure.

Gauges

Most pumps are drilled and tapped for installing discharge pressure and vacuum suction gauges. If these gauges are desired for pumps that are not tapped, drill and tap the suction and discharge lines not less than 18 inches from the suction and discharge ports and install the lines. Installation closer to the pump may result in erratic readings.

SUCTION LINES

To avoid air pockets which could affect pump priming, the suction line must be as short and direct as possible. When operation involves a suction lift, the line must always slope upward to the pump from the source of the liquid being pumped; if the line slopes down to the pump at any point along the suction run, air pockets will be created.

Fittings

Suction lines should be the same size as the pump inlet. If reducers are used in suction lines, they should be the eccentric type, and should be installed with the flat part of the reducers uppermost to avoid creating air pockets. Valves are not normally used in suction lines, but if a valve is used, install it with the stem horizontal to avoid air pockets.

Strainers

If a strainer is furnished with the pump, be certain to use it; any spherical solids which pass through a strainer furnished with the pump will also pass through the pump itself.

If a strainer is not furnished with the pump, but is installed by the pump user, make certain that the total area of the openings in the strainer is at least three or four times the cross section of the suction line, and that the openings will not permit passage of solids larger than the solids handling capability of the pump.

This pump is designed to handle up to 3 1/2 inch diameter spherical solids.

Sealing

Since even a slight leak will affect priming, head, and capacity, especially when operating with a high suction lift, all connections in the suction line should be sealed with pipe dope to ensure an airtight seal. Follow the sealant manufacturer's recommendations when selecting and applying the pipe dope. The pipe dope should be compatible with the liquid being pumped.

Suction Lines In Sumps

If a single suction line is installed in a sump, it should be positioned away from the wall of the sump at a distance equal to one and one-half times the diameter of the suction line.

If there is a liquid flow from an open pipe into the sump, the flow should be kept away from the suction inlet because the inflow will carry air down into the sump, and air entering the suction line will reduce pump efficiency.

If it is necessary to position inflow close to the suction inlet, install a baffle between the inflow and the suction inlet at a distance one and one-half times the diameter of the suction pipe. The baffle will allow entrained air to escape from the liquid before it is drawn into the suction inlet.

If two suction lines are installed in a single sump, the flow paths may interact, reducing the efficiency of one or both pumps. To avoid this, position the suction inlets so that they are separated by a distance equal to at least three times the diameter of the suction pipe.

Suction Line Positioning

The depth of submergence of the suction line is critical to efficient pump operation. Figure 1 shows recommended minimum submergence vs. velocity.

NOTE

The pipe submergence required may be reduced by installing a standard pipe increaser fitting at the end of the suction line. The larger opening size will reduce the inlet velocity. Calculate the required submergence using the following formula based on the increased opening size (area or diameter).

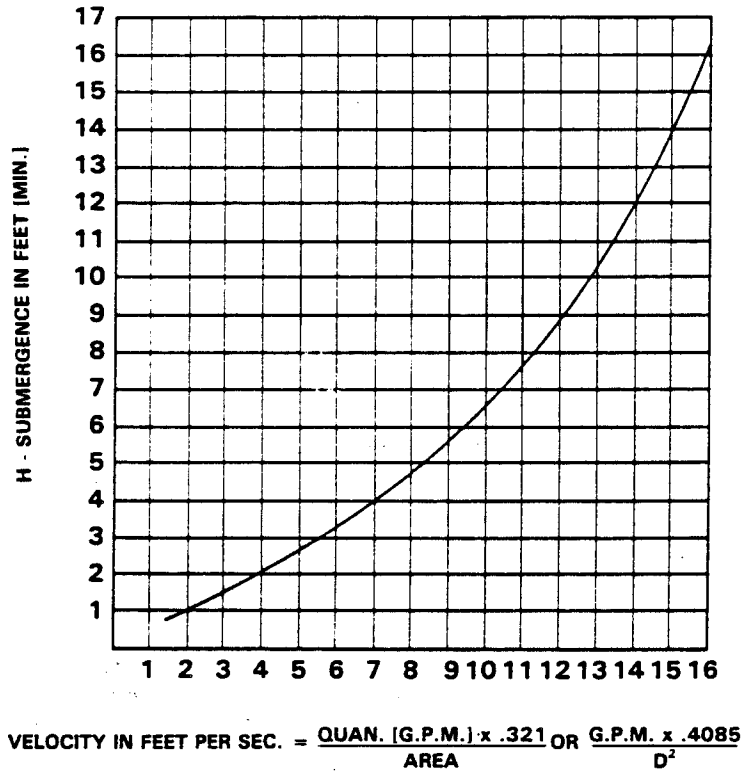

Figure 1. Recommended Minimum Suction Line Submergence Vs. Velocity

DISCHARGE LINES

Siphoning

Do not terminate the discharge line at a level lower than that of the liquid being pumped unless a siphon breaker is used in the line. Otherwise, a siphoning action causing damage to the pump could result.

Valves

If a throttling valve is desired in the discharge line, use a valve as large as the largest pipe to minimize friction losses. Never install a throttling valve in a suction line.

With high discharge heads, it is recommended that a throttling valve and a check valve be installed in the discharge line to protect the pump from excessive shock pressure and reverse rotation when it is stopped.

ALIGNMENT

The alignment of the pump and the engine is critical for trouble free mechanical operation. See Section E, **Securing Pump To Engine** for detailed information.

OPERATION

OPERATION - SECTION C

WARNING

```

////////////////////////////////////
//
// This pump is designed to pump liquids which contain //
// large entrained solids. Do not attempt to pump //
// volatile, corrosive, or flammable liquids which may dam- //
// age the pump or endanger personnel as a result of pump //
// failure. //
// //
////////////////////////////////////

```

WARNING

```

////////////////////////////////////
//
// Never tamper with the governor to gain more power. The //
// governor establishes safe operating limits that should //
// not be exceeded. The maximum continuous operating speed //
// is 1600 RPM. //
// //
////////////////////////////////////

```

PRIMING

Install the pump and piping as described in INSTALLATION. Make sure that the piping connections are tight, and that the pump is securely mounted. Check that the pump is properly lubricated (see LUBRICATION in MAINTENANCE AND REPAIR).

Since this is not a self-priming pump, it will require an external priming device when installed in a **static lift application**. Many standard centrifugal models are equipped with a hand operated vacuum pump, exhaust primer, or ejector for this purpose. If a priming device was not furnished with the pump, it may be ordered from the factory as an option.

Before attempting to operate the priming device, close the discharge throttling valve. (Installation of a spring-loaded check valve is also recommended to facilitate priming.) Once the pump is fully primed, close the valve between the priming device and pump to preserve the prime. Start the pump, if not already in operation, and open the discharge valve slowly and fill the discharge line.

When installed in a **flooded suction application**, simply open the system valves and permit the incoming liquid to evacuate the air. After the pump and piping system have completely filled, evacuate any remaining air pockets in the pump or suction line by loosening pipe plugs or opening bleeder valves.

CAUTION

Never operate this pump unless there is liquid in the pump casing. The pump will not prime when dry. Extended operation of a dry pump will destroy the seal assembly.

Hand-Operated Priming Pump

The hand-operated priming pump (see Figure 1) is designed to draw air out of the suction line and the pump casing.

The hand-operated priming pump can be used while the pump is either stopped or operating.

Close the discharge line throttling valve and spring-loaded check valve (if so equipped) before engaging the priming device.

To prime the pump, open the cock in the bottom of the priming pump. Operate the handle of the pump until all of the air is expelled from the line and a small amount of liquid flows from the drain cock.

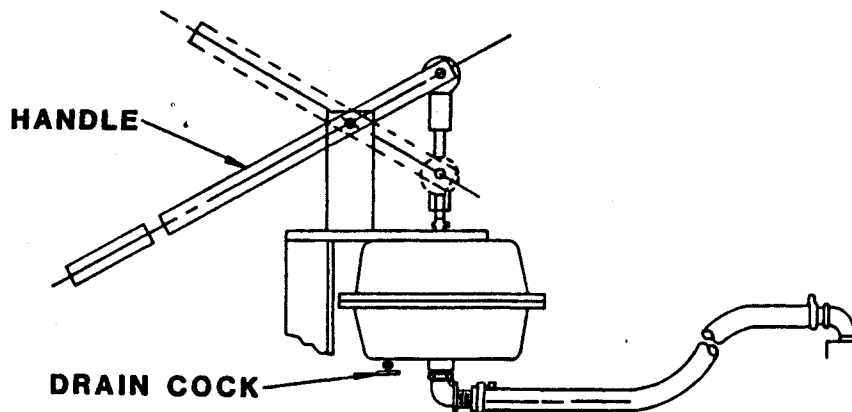

Figure 1. Hand Primer Assembly

Once the pump is fully primed, close the cock, open the discharge line throttling valve and start the pump.

STARTING

Consult the operations manual furnished with the engine.

OPERATION

Leakage

No leakage should be visible at pump mating surfaces, or at pump connections or fittings. Keep all line connections and fittings tight to maintain maximum pump efficiency.

Liquid Temperature And Overheating

The maximum liquid temperature for this pump is 110°F. Do not apply it at a higher operating temperature.

Overheating can occur if operated with the valves in the suction or discharge lines closed. Operating against closed valves could bring the liquid to a boil, build pressure, and cause the pump to rupture or explode. If overheating occurs, stop the pump and allow it to cool before servicing it. Refill the pump casing with cool liquid.

WARNING

```

////////////////////////////////////
//                               //
// Do not remove plates, covers, gauges, pipe plugs, or //
// fittings from an overheated pump. Vapor pressure within //
// the pump can cause parts being disengaged to be ejected //
// with great force. Allow the pump to cool before servic- //
// ing.                               //
//                               //
////////////////////////////////////

```

Strainer Check

If a suction strainer has been shipped with the pump or installed by the user, check the strainer regularly, and clean it as necessary. The strainer should also be checked if pump flow rate begins to drop. If a vacuum suction gauge has been installed, monitor and record the readings regularly to detect strainer blockage.

Pump Vacuum Check

Since this pump does not have a suction check valve, the discharge line must be fitted with a check valve if a pump vacuum reading is to be taken.

With the pump inoperative, install a vacuum gauge in the system, using pipe dope on the threads. Block the suction line and start the pump. At operating speed the pump should pull a vacuum of 20 inches or more of mercury. If it does not, check for air leaks in the seal, gasket, or discharge valve.

OPERATION

Open the suction line, and read the vacuum gauge with the pump primed and at operation speed. Shut off the pump. The vacuum gauge reading will immediately drop proportionate to static suction lift, and should then stabilize. If the vacuum reading falls off rapidly after stabilization, an air leak exists. Before checking for the source of the leak, check the point of installation of the vacuum gauge.

STOPPING

Never halt the flow of liquid suddenly. If the liquid being pumped is stopped abruptly, damaging shock waves can be transmitted to the pump and piping system. Close all connecting valves slowly. If the pump is driven by an engine, reduce the throttle speed slowly and allow the engine to idle briefly before stopping.

CAUTION

If application involves a high discharge head, gradually close the discharge throttling valve before stopping the pump.

After stopping the pump, remove the engine ignition key or take other action to ensure that the pump will remain inoperative.

Cold Weather Preservation

In below freezing conditions, drain the pump to prevent damage from freezing. Also, clean out any solids by flushing with a hose. Operate the pump for approximately one minute; this will remove any remaining liquid that could freeze the pump rotating parts.

If the pump will be idle for more than a few hours, or if it has been pumping liquids containing a large amount of solids, drain the pump, and flush it thoroughly with clean water. To prevent large solids from clogging the drain port and preventing the pump from completely draining, insert a rod or stiff wire in the drain port, and agitate the liquid during the draining process. Clean out any remaining solids by flushing with a hose.

BEARING TEMPERATURE CHECK

Bearings normally run at higher than ambient temperatures because of heat generated by friction. Temperatures up to 160°F are considered normal for bearings, and they can operate safely to at least 180°F.

Checking bearing temperatures by hand is inaccurate. Bearing temperatures can be measured accurately by placing a contact-type thermometer against the housing. Record this temperature for future reference.

A sudden increase in bearing temperatures is a warning that the bearings are at the point of failing to operate properly. Make certain that the bearing lubricant is of the proper viscosity and at the correct level (see LUBRICATION in MAINTENANCE AND REPAIR). Bearing overheating can also be caused by shaft misalignment and/or excessive vibration.

When pumps are first started, the bearings may seem to run at temperatures above normal. Continued operation should bring the temperatures down to normal levels.

PUMP TROUBLESHOOTING - SECTION D

WARNING

```

////////////////////////////////////
//
// Before attempting to open or service the pump:
//
// 1. Familiarize yourself with this manual.
// 2. Switch off the engine ignition key and remove the
// key to ensure that the pump will remain inopera-
// tive.
// 3. Allow the pump to cool if overheated.
// 4. Vent the pump slowly and cautiously.
// 5. Close the suction and discharge valves.
// 6. Check the temperature before opening any covers,
// plates, or plugs.
// 7. Drain the pump.
//
////////////////////////////////////

```

TROUBLE	POSSIBLE CAUSE	PROBABLE REMEDY
PUMP FAILS TO PRIME	<p>Air leak in suction line.</p> <p>Lining of suction hose collapsed.</p> <p>Leaking or worn seal or pump gasket.</p> <p>Suction check valve or foot valve clogged or binding.</p> <p>Suction lift or discharge head too high.</p> <p>Strainer clogged.</p>	<p>Correct leak.</p> <p>Replace suction hose.</p> <p>Check pump vacuum. Replace leaking or worn seal or gasket.</p> <p>Clean valve.</p> <p>Check piping installation and install bypass line if needed. See INSTALLATION.</p> <p>Check strainer and clean if necessary.</p>
PUMP STOPS OR FAILS TO DELIVER RATED FLOW OR PRESSURE	<p>Air leak in suction line.</p> <p>Suction intake not submerged at proper level or sump too small.</p> <p>Lining of suction hose collapsed.</p> <p>Impeller or other wearing parts worn or damaged.</p>	<p>Correct leak.</p> <p>Check installation and correct as needed. Check submergence chart (Section B).</p> <p>Replace suction hose.</p> <p>Replace worn or damaged parts. Check that impeller is properly centered and rotates freely.</p>

TROUBLE	POSSIBLE CAUSE	PROBABLE REMEDY
PUMP STOPS OR FAILS TO DELIVER RATED FLOW OR PRESSURE(cont.)	<p>Impeller clogged.</p> <p>Pump speed too slow.</p> <p>Discharge head too high.</p> <p>Suction lift too high.</p> <p>Leaking or worn seal or pump gasket.</p> <p>Strainer clogged.</p>	<p>Free impeller of debris.</p> <p>Check engine output; consult engine operation manual.</p> <p>Install bypass line.</p> <p>Measure lift w/vacuum gauge. Reduce lift and/or friction losses in suction line.</p> <p>Check pump vacuum. Replace leaking or worn seal or gasket.</p> <p>Check strainer and clean if necessary.</p>
PUMP REQUIRES TOO MUCH POWER	<p>Pump speed too high.</p> <p>Discharge head too low.</p> <p>Liquid solution too thick.</p>	<p>Check engine output.</p> <p>Adjust discharge valve.</p> <p>Dilute if possible.</p>
PUMP CLOGS FREQUENTLY	<p>Discharge flow too slow.</p> <p>Suction check valve or foot valve clogged or binding.</p>	<p>Open discharge valve fully to increase flow rate, and run engine at maximum governed speed.</p> <p>Clean valve.</p>
EXCESSIVE NOISE	<p>Cavitation in pump.</p> <p>Pumping entrained air.</p> <p>Pump or drive not securely mounted.</p> <p>Impeller clogged or damaged.</p>	<p>Reduce suction lift and/or friction losses in suction line. Record vacuum and pressure gauge readings and consult local representative or factory.</p> <p>Locate and eliminate source of air bubble.</p> <p>Secure mounting hardware.</p> <p>Clean out debris; replace damaged parts.</p>

TROUBLE	POSSIBLE CAUSE	PROBABLE REMEDY
BEARINGS RUN TOO HOT	Bearing temperature is high, but within limits. Low or incorrect lubricant. Suction and discharge lines not properly supported. Drive misaligned.	Check bearing temperature regularly to monitor any increase. Check for proper type and level of lubricant. Check piping installation for proper support. Align drive properly.

PUMP MAINTENANCE AND REPAIR - SECTION E

MAINTENANCE AND REPAIR OF THE WEARING PARTS OF THE PUMP WILL MAINTAIN PEAK OPERATING PERFORMANCE.

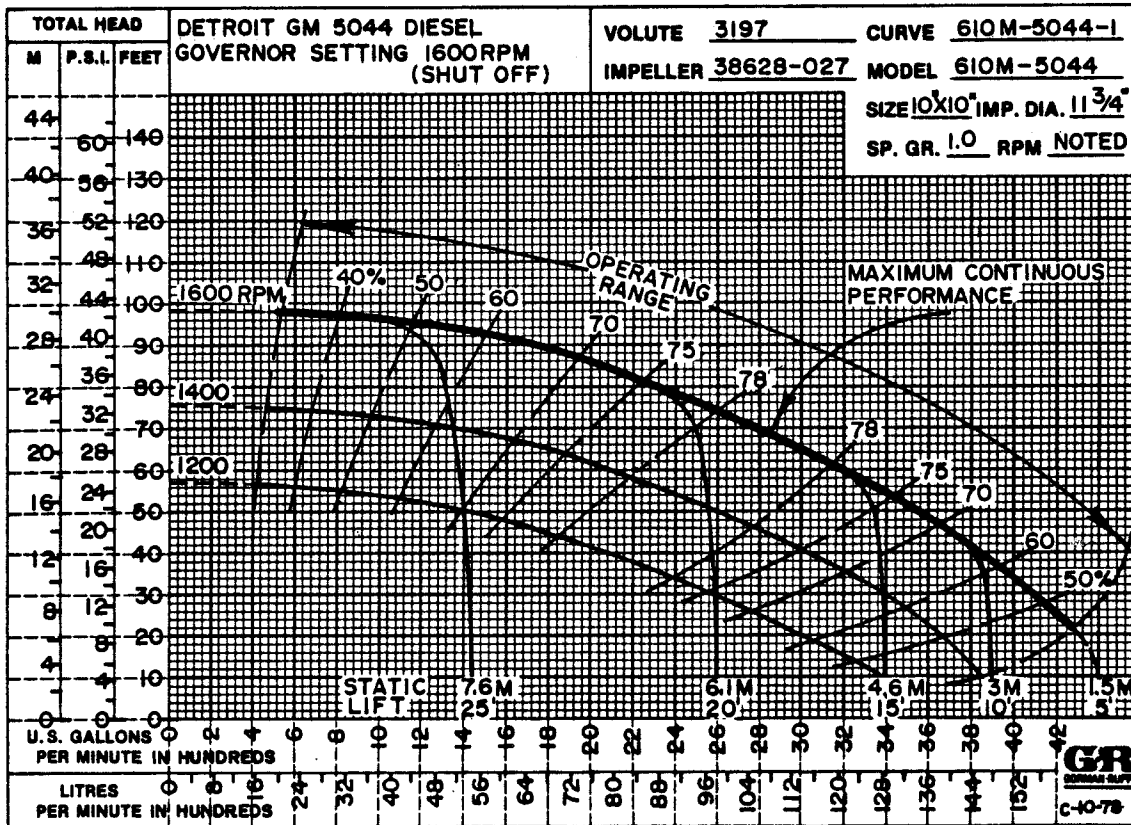

*STANDARD PERFORMANCE FOR PUMP MODEL 610M2-5044

*Based on 70°F clear water at sea level with minimum suction lift. Since pump installations are seldom identical, your performance may be different due to such factors as viscosity, specific gravity, elevation, temperature, and impeller trim.

If your pump serial number is followed by an "N", your pump is NOT a standard production model. Contact the Gorman-Rupp Company to verify performance or part numbers.

CAUTION

Pump speed and operating condition points must be within the continuous performance range shown on the curve.

SECTIONAL DRAWING

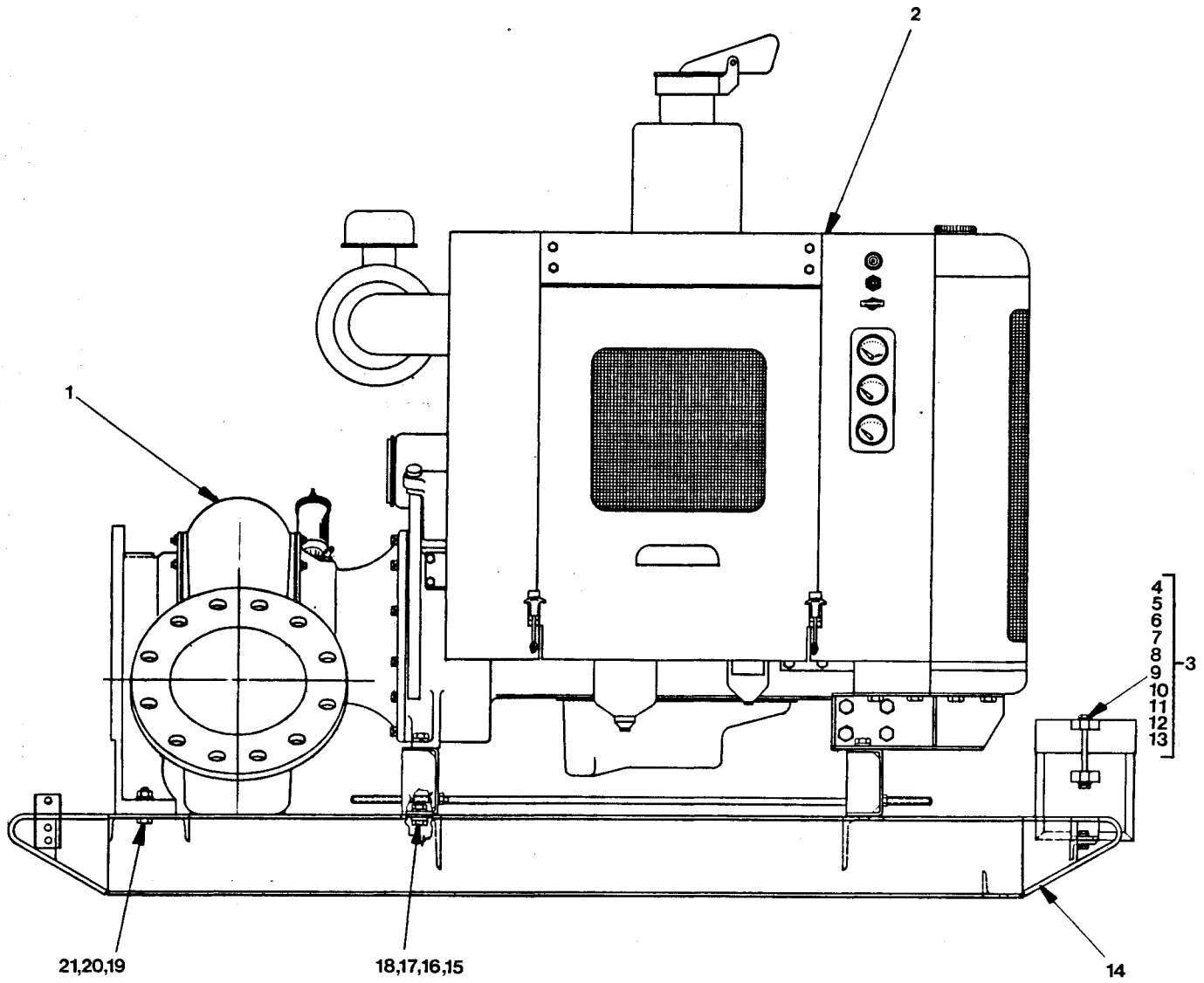

Figure 1. Pump Model Assembly 610M2-5044

PARTS LIST
Pump Model Assembly 610M2-5044
 (From S/N 776410 up)

ITEM NO.	PART NAME	PART NUMBER	MATL CODE	QTY
1	PUMP END ASSY	610M2	-----	1
2	GM 5044 ENGINE	206-E2	-----	1
3	BATTERY BOX ASSY	GRP40-04	-----	1
4	* -BATTERY BOX COVER	4896-X	24000	1
5	-CONNECTOR CABLE ASSY	5795-CR	24040	1
6	-BATTERY BOX	10478	24000	1
7	-HEX HD CAPSCREW	B00604	15991	1
8	-HEX HD CAPSCREW	B00605	15991	1
9	-HEX HD CAPSCREW	B00624	15991	2
10	-HEX NUT	D00006	15991	4
11	-LOCKWASHER	J00006	15991	4
12	-FLAT WASHER	K00006	15991	6
13	* -BATTERY	S00978	-----	2
14	COMBINATION BASE	13202	24000	1
15	HEX HD CAPSCREW	B01205	15991	4
16	FLAT WASHER	K00012	15991	4
17	LOCKWASHER	J00012	15991	4
18	HEX NUT	D00012	15991	4
19	HEX HD CAPSCREW	B01009	15991	2
20	LOCKWASHER	J00010	15991	2
21	HEX NUT	D00010	15991	2
NOT SHOWN:				
	BATTERY TAG	6588-S	00000	1
	* GROUND CABLE ASSY	5795-AC	24040	1
	* POSITIVE CABLE ASSY	6926-W	24040	1
	STREET ELBOW	RS00004	11990	1
	FUEL LINE RETURN	12620-D	-----	1
	FUEL LINE SUPPLY	12620-C	-----	1
	CONNECTOR	S01447	-----	REF
OPTIONAL:				
	PNEU TRUCK ASSY	GRP30-26A	-----	1
	SUCTION DISCHARGE FLANGE	2751	10010	2
	DISCHARGE CHECK VALVE	GRP14-05	-----	1
	HAND PRIMER ASSY	GRP43-01C	-----	1
	PRESSURE SWITCH ASSY	48312-005	-----	1

*INDICATES PARTS RECOMMENDED FOR STOCK

Above Serial Numbers Do Not Apply To Pumps Made In Canada.

CANADIAN SERIAL NO. AND UP

SECTIONAL DRAWING

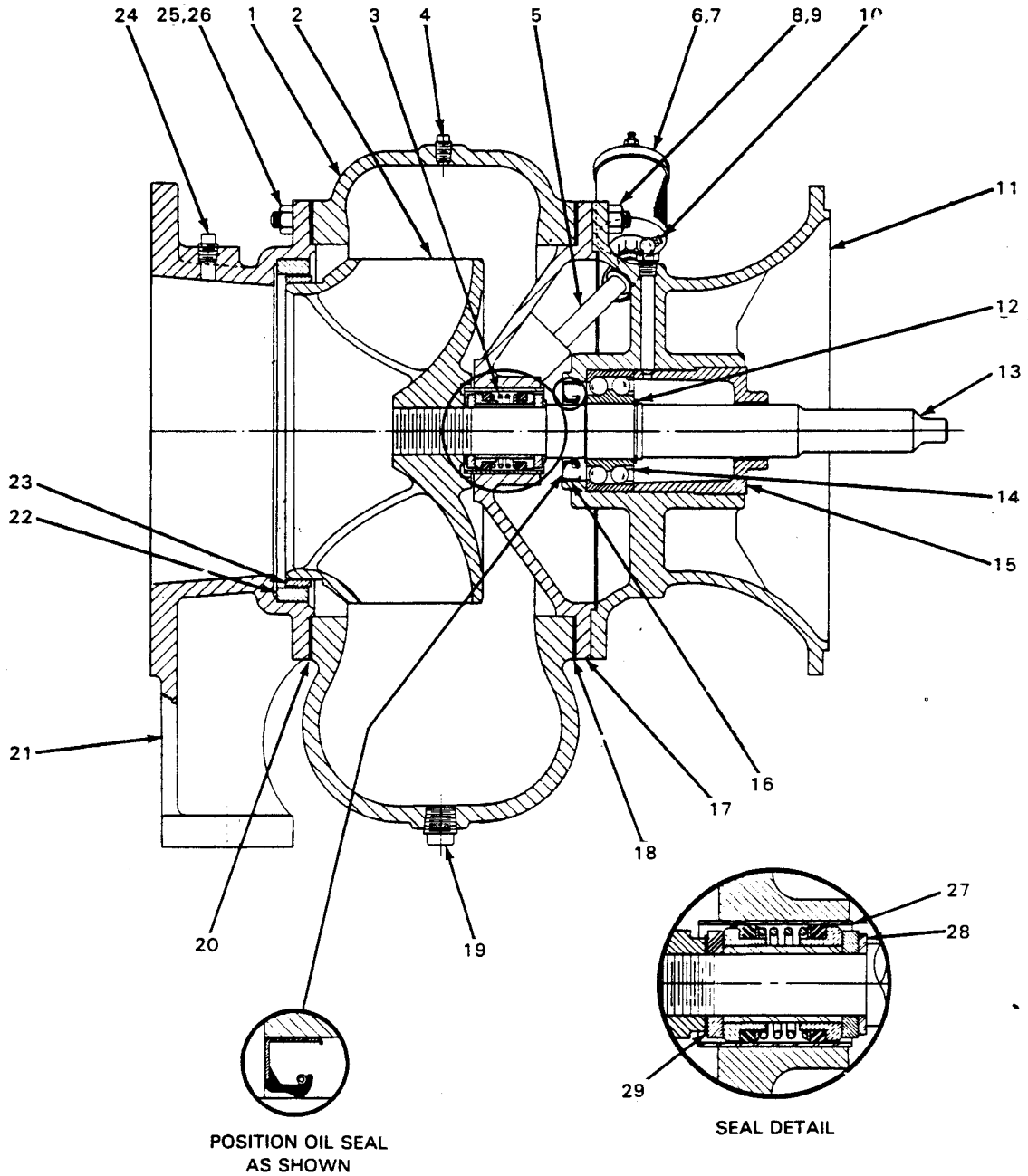

Figure 2. Pump End Assembly 610M2-5044

PARTS LIST
Pump End Assembly 610M2-5044

ITEM NO.	PART NAME	PART NUMBER	MATL CODE	QTY
1	PUMP CASING	3197	10010	1
2	* IMPELLER	38628-027	11000	1
3	* SEAL ASSY	GS01500	-----	1
4	PIPE PLUG	P00004	11990	3
5	PIPE NIPPLE	THA00416	15070	1
6	GREASE CUP	S01509	-----	1
7	PIPE ELBOW	AG00004	11990	1
8	STUD	C00809	15991	12
9	HEX NUT	D00008	15991	12
10	LUBE FITTING	S00194	-----	1
11	INTERMEDIATE	3199-B	10010	REF
12	BEARING RETAINING RING	S00264	-----	2
13	* IMPELLER SHAFT	38524-009	16040	REF
14	* BALL BEARING	S01034	-----	1
15	BEARING RETAINING NUT	3202	10010	1
16	* OIL SEAL	S00079	-----	1
17	SEAL PLATE	3200	10010	1
18	* PUMP CASING GSKT	3200-G	18000	1
19	CASING DRAIN PLUG	P00016	11990	1
20	* SUCTION HEAD GSKT	3200-G	18000	1
21	SUCTION HEAD	3201	10010	1
22	* SUCTION HEAD WEAR RING	3203	10010	1
23	* IMPELLER WEAR RING	3204	14000	1
24	PIPE PLUG	P00006	11990	1
25	STUD	C00807	15991	12
26	HEX NUT	D00008	15991	12
27	* SEAL LINER	7408	14010	1
28	SEAL WASHER	8065	15010	1
29	* IMPELLER SHIM SET	5091	17090	REF
NOT SHOWN:				
	SETSCREW	G00604	15990	1
	NAME PLATE	2613-AY	13990	1
	STRAINER	3756	-----	1

*INDICATES PARTS RECOMMENDED FOR STOCK

SECTIONAL DRAWING

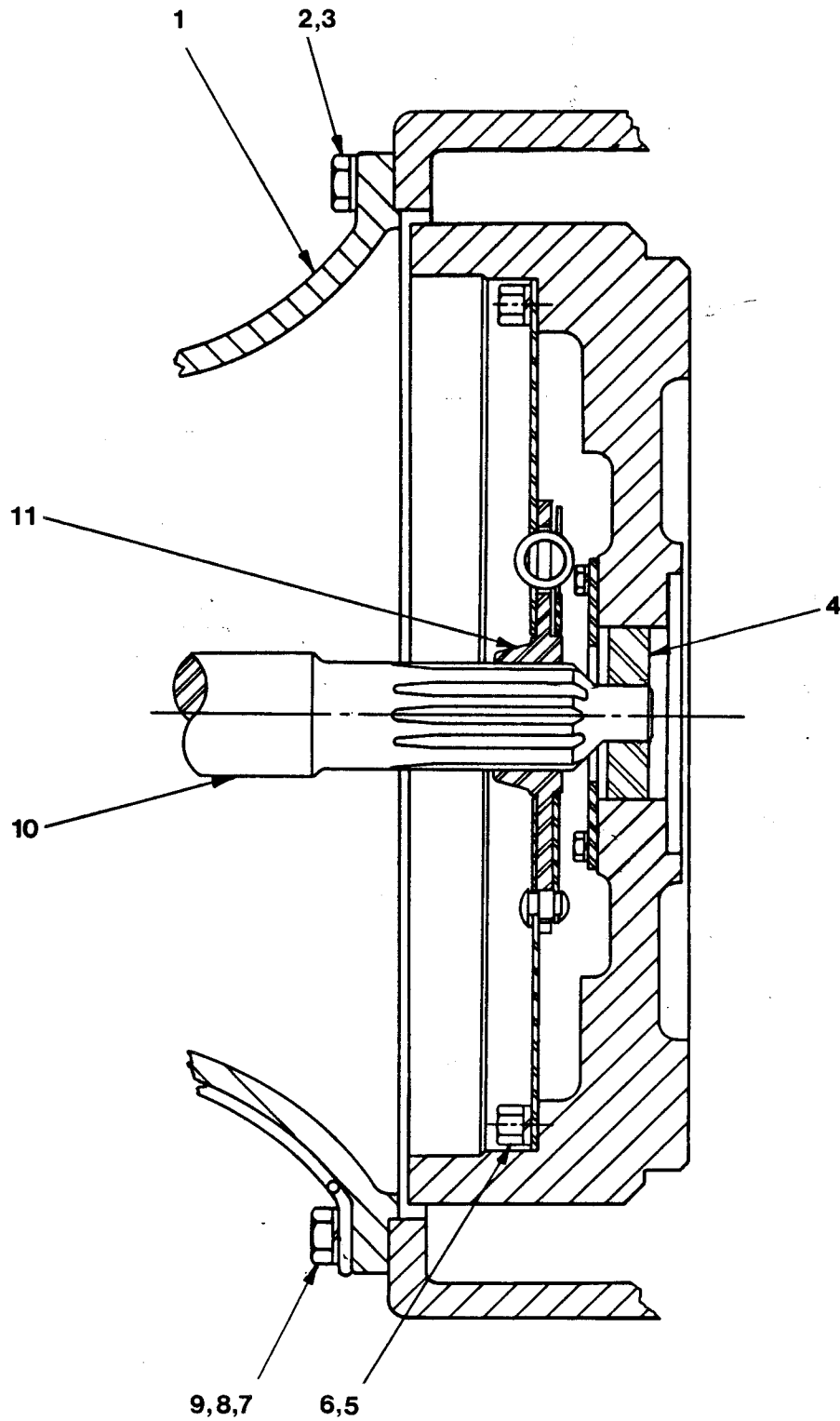

Figure 3. Drive Assembly For Model 610M2-5044

PARTS LIST
Drive Assembly For Model 610M2-5044

ITEM NO.	PART NAME	PART NUMBER	MATL CODE	QTY
1	INTERMEDIATE	3199-B	10010	1
2	HEX HD CAPSCREW	B00605	15991	8
3	LOCKWASHER	J00006	15991	8
4	* BUSHING	12307	15010	1
5	HEX HD CAPSCREW	B00603	15991	8
6	LOCKWASHER	J00006	15991	8
7	HEX HD CAPSCREW	B00606	15991	4
8	LOCKWASHER	J00006	15991	4
9	INTERMEDIATE GUARD	42381-031	24150	2
10	* IMPELLER SHAFT	38524-009	16040	1
11	DRIVE PLATE ASSEMBLY	24521-165	24020	1

*INDICATES PARTS RECOMMENDED FOR STOCK

PUMP AND SEAL DISASSEMBLY AND REASSEMBLY

This pump requires little service due to its rugged, minimum-maintenance design. However, if it becomes necessary to inspect or replace the wearing parts, follow these instructions which are keyed to the sectional views (see Figures 1, 2, and 3) and the accompanying parts lists.

Most service functions may be performed by draining the pump and removing the suction piping and suction head. If major repair is required, the discharge piping and/or engine must be disconnected.

Before attempting to service the pump, take precautions to ensure that the engine will remain inoperative. Close all connecting valves in the suction and discharge lines.

For engine disassembly and repair, consult the literature supplied with the engine or contact your local engine representative.

WARNING

```

////////////////////////////////////
//
// Before attempting to open or service the pump:
//
// 1. Familiarize yourself with this manual.
// 2. Switch off the engine ignition key and remove the
// key to ensure that the pump will remain inopera-
// tive.
// 3. Allow the pump to cool if overheated.
// 4. Vent the pump slowly and cautiously.
// 5. Close the suction and discharge valves.
// 6. Check the temperature before opening any covers,
// plates, or plugs.
// 7. Drain the pump.
//
////////////////////////////////////

```

WARNING

```

////////////////////////////////////
//
// Use lifting and moving equipment in good repair and with
// adequate capacity to prevent injuries to personnel or
// damage to equipment.
//
////////////////////////////////////

```

Suction Head Removal

(Figure 2)

The impeller, wear rings and seal assembly may be serviced by removing the suction head (21).

Remove the casing drain plug (19) and drain the pump. Clean and reinstall the drain plug.

Disconnect the suction piping. Remove the hardware (19, 20 and 21, Figure 1) securing the suction head to the base.

Before attempting to remove the suction head, support the pump body by wedging a block of wood under the pump casing and wrapping a sling around the intermediate. Attach the sling to a hoist and use the hoist **only** to support the pump; **do not** try to lift it.

Remove the hardware (26) and separate the suction head and gasket (20) from the pump casing (1).

Inspect the suction head wear ring for excessive wear or damage. If replacement is necessary, use a gear puller to remove the wear ring from the suction head.

Impeller Disassembly

(Figure 2)

Inspect the impeller wear ring (22). If replacement is necessary, use a gear puller to remove the wear ring from the impeller (2).

To remove the impeller, use a block of wood or a soft-faced mallet to tap the vanes in a counterclockwise direction (when facing the impeller). Be careful not to damage the vanes. Use caution when unscrewing the impeller; tension of the seal spring will be released as the impeller is removed.

Remove the impeller adjusting shims (29). For ease of reassembly, tag and tie the shims or measure and record their thickness.

If no further disassembly is required, see **Impeller Reassembly and Adjustment**.

Seal Disassembly

(Figure 2)

Before removing the seal assembly, turn the cross arm on the grease cup (6) clockwise until it rests against the cover (see Figure 5). This will prevent the grease in the cup from escaping after the seal is removed.

Remove the outer rotating element, stationary seat, packing ring, stationary washer and the seal spring. Remove the shaft sleeve. Remove the inner stationary washer, packing ring, stationary seat and rotating element using a stiff wire with a hooked end if necessary. Remove the seal washer (28).

Inspect the seal liner (27) for wear or grooves which could cause leakage or damage to the seal packing rings. The liner is a press fit in the seal plate (17) and if replacement is necessary, the pump casing and seal plate must be separated from the intermediate (see **Pump Disassembly**).

If no further disassembly is required, see **Seal Reassembly**.

Pump Disassembly

(Figure 2)

To service the seal liner or seal plate, the pump casing must be separated from the intermediate.

Remove the grease cup and piping (5, 6, and 7). Disconnect the discharge piping.

Use a hoist and sling to support the pump casing and remove the hardware (9). Separate the casing, gasket (18) and seal plate (17) from the intermediate.

To replace the seal liner, see **Pump Reassembly**.

Separating Intermediate From Engine

(Figure 3)

Use a hoist and sling to support the intermediate and remove the hardware (2, 3, 7 and 8) securing the intermediate to the engine bellhousing and remove the intermediate guards (9). Separate the two assemblies by pulling the intermediate straight away from the engine.

As the assemblies are separated, the impeller shaft (10) will disengage from the drive plate assembly (11).

It is not necessary to remove the drive plate assembly from the engine flywheel unless the pilot bushing (4) is worn and requires replacement. If replacement is necessary, disengage the hardware (5 and 6) and remove the drive plate assembly. Remove the hardware and plate (furnished with the engine) covering the bushing and use a bearing puller to remove the pilot bushing.

Impeller Shaft And Bearing Disassembly

(Figure 1).

Properly lubricated bearings should provide long service life. Do not disassemble the intermediate unless there are indications of bearing failure, or unless damage to the intermediate or impeller shaft is suspected.

CAUTION

Shaft and bearing disassembly in the field is not recommended. These operations should be performed only in a properly-equipped shop by qualified personnel.

After separating the pump end from the engine reach through the back of the intermediate, loosen the square head setscrew (not shown) and unscrew the retaining nut (15) out of the intermediate.

NOTE

There is no provision for draining the grease from the intermediate cavity. Place a drip pan under the intermediate before removing the retaining nut.

Place a block of wood against the impeller end of the shaft and drive the shaft and assembled bearing (14) out of the intermediate.

Remove the bearing retaining ring (12) and use a bearing puller to remove the bearing from the impeller shaft.

Inspect the oil seal (16) for wear or damage. If replacement is necessary, press the seal from the intermediate bore.

Impeller Shaft And Bearing Reassembly

(Figure 2)

Remove the grease fitting (10) from the intermediate and flush the old bearing lubricant from the cavity. Clean the bore of the intermediate, impeller shaft, and all component parts (except the bearing) with a soft cloth soaked in cleaning solvent. Inspect the parts for wear, and replace as necessary.

WARNING

Warning text enclosed in slashes: // Most cleaning solvents are toxic and flammable. Use them only in a well-ventilated area free from excessive heat, sparks, and flame. Read and follow all precautions printed on solvent containers.

Inspect the shaft for distortion, for nicks and scratches on the oil seal seating surfaces, and for thread damage on the impeller end. Dress the threads, nicks and burrs on the shaft with a fine file or honing stone. Replace the impeller shaft if defective.

To prevent contamination, wash the bearing thoroughly in fresh cleaning solvent, agitating to remove all old lubricant. Dry the bearing with filtered compressed air and coat with a light oil.

Rotate the bearing by hand to check for rough or binding rotation, and inspect the bearing balls. If the bearing rotation is rough or the balls are discolored replace the bearing.

CAUTION

Bearings must be kept free of all dirt and foreign material. Failure to do so will greatly shorten bearing life. DO NOT spin dry bearings. This may scratch the balls or races and cause premature bearing failure.

Pre-pack the bearing with #0 grease by hand (or use a bearing packer if available) until the bearing balls are thoroughly lubricated.

The bearing is a tight press fit onto the impeller shaft and a snug push fit into the intermediate. If the shaft is worn so that the bearing slips on and off easily, the shaft must be replaced. The intermediate housing must be replaced if the bearing does not fit snugly.

Position the bearing so that the loading groove faces away from the impeller end of the shaft and press it on until squarely seated against the shaft shoulder. Secure the bearing with the retaining ring (12).

CAUTION

When installing the bearings onto the shaft, NEVER press or hit against the outer race, balls, or ball cage. Press ONLY on the inner race.

If the oil seal was removed during disassembly, install it into the intermediate bore with the lip positioned as shown in Figure 2.

Push the shaft and assembled bearing into the intermediate bore until the outer race of the bearing seats squarely against the intermediate shoulder. Be careful not to damage the oil seal already installed.

CAUTION

When installing the shaft and bearings into the bearing bore, push against the outer race. NEVER hit the balls or ball cage.

Reinstall the retaining nut (15) into the intermediate and secure it with the square head set screw.

NOTE

Shaft endplay should be between .002 - .010 inch. Adjust the retaining nut to establish the correct endplay.

Reinstall the lubrication fitting (10) and lubricate the bearing cavity as indicated in LUBRICATION, Section E.

Securing Intermediate To Pump

(Figure 2)

Press the pilot bushing (4) into the engine flywheel and apply a coating of 'Never-Seez' lubricant to the inside diameter. Make certain the bushing does not protrude and preload the shaft and bearing.

CAUTION

If the pilot bushing and drive plate are not properly positioned on the shaft, excessive wear and a preload condition could cause premature thrust bearing failure.

Install the pilot bushing retainer plate.

Secure the drive plate assembly to the flywheel as shown in Figure 3 with the previously removed hardware.

Slide the shaft splines into the drive plate and use the hardware (2, 3, 7 and 8) to secure the intermediate assembly and guards to the engine bellhousing.

Be sure to reinstall any leveling shims used under the pump mounting feet before installing the base mounting hardware.

Pump Reassembly

(Figure 2)

Before securing the seal plate to the intermediate inspect the bore of the seal liner (27) for wear or grooves which might cause leakage or damage to the seal packing rings. If the seal liner must be replaced, position the seal plate (17) on the bed of an arbor (or hydraulic) press and use a new sleeve to force the old one out. After the new liner is properly installed, a 1/4 inch diameter hole must be drilled through it to permit the flow of lubricant to the seal assembly. **Be careful** to center the drill in the threaded grease pipe hole and not damage the threads. Deburr the hole from the inside of the seal liner after drilling.

NOTE

For ease of assembly, it is recommended that the seal and impeller be reassembled before installing the pump casing. To accomplish this, temporarily secure the seal plate to the intermediate using four 1/2 - 16 X 1 1/2 NC capscrews and four of the hex nuts (9). Refer to **Seal Reassembly and Impeller Reassembly And Adjustment**. When these steps have been completed, remove the four capscrews and proceed as follows:

Install a new casing gasket (18) and secure the pump casing and seal plate to the intermediate using the previously removed hardware (9).

Reinstall the automatic grease cup and piping (5, 6 and 7).

Seal Reassembly

(Figure 2 and 4)

Clean the seal cavity and shaft with a cloth soaked in fresh cleaning solvent.

WARNING

```

////////////////////////////////////
//
// Most cleaning solvents are toxic and flammable. Use //
// them only in a well-ventilated area free from excessive //
// heat, sparks, and flame. Read and follow all prec- //
// autions printed on solvent containers. //
// //
////////////////////////////////////

```

The seal is not normally reused because wear patterns on the finished faces cannot be realigned during reassembly. This could result in premature failure. If necessary to reuse an old seal in an emergency, **carefully** wash all metallic parts in fresh cleaning solvent and allow to dry thoroughly.

Handle the seal parts with extreme care to prevent damage. Be careful not to contaminate precision finished faces; even fingerprints on the faces can shorten seal life. If necessary, clean the faces with a non-oil based solvent and a clean lint free tissue. Wipe **lightly** in a concentric pattern to avoid scratching the faces.

Inspect the seal components for wear, scoring, grooves, and other damage that might cause leakage. Clean and polish the seal spacer sleeve, or replace it if there are nicks or cuts on either end. If any components are worn, replace the complete seal; **never mix old and new seal parts**.

If a replacement seal is being used, remove it from the container and inspect the precision finished faces to ensure that they are free of any foreign matter.

To ease installation of the seal, lubricate the packing rings and seal liner with water or a very **small** amount of oil, and apply a drop of light lubricating oil on the finished faces. Assemble the seal as follows, (see Figure 4).

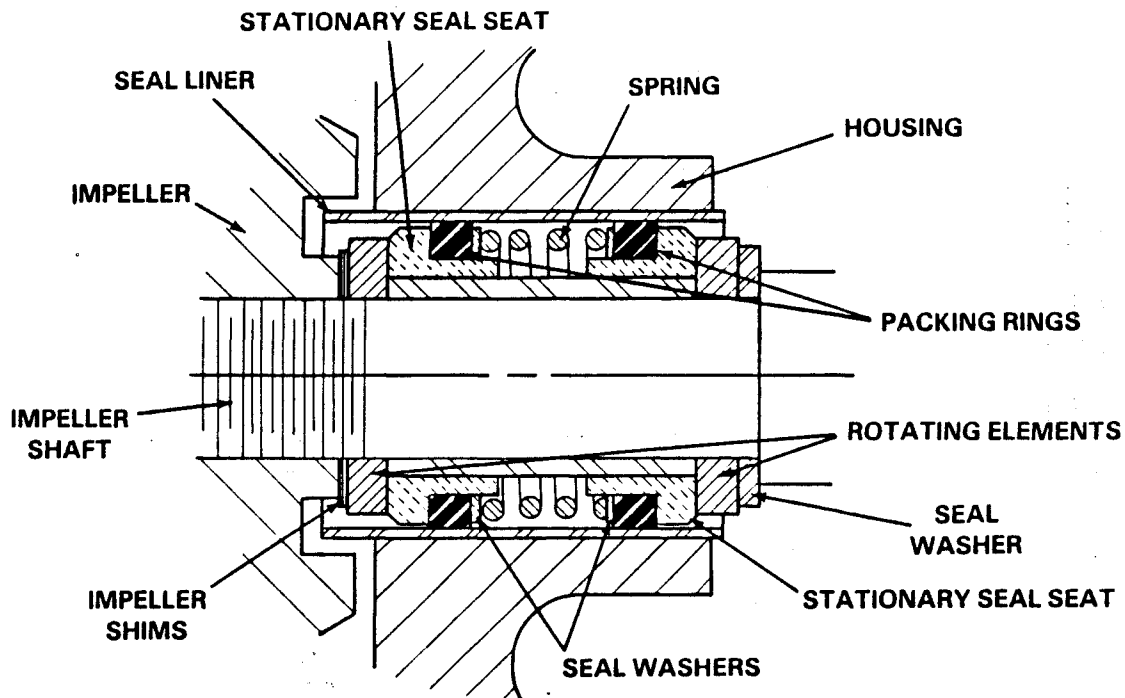

Figure 4. GS01500 Seal Assembly

CAUTION

This seal is not designed for operation at temperatures above 110°F. Do not use at higher operating temperatures.

Install the seal washer (28) with the chamfered side toward the shaft shoulder.

Install the inboard rotating element.

Subassemble the inboard stationary seat, packing ring and stationary washer onto the shaft sleeve. Install the subassembly onto the shaft until the shaft sleeve and stationary seat bottom against the rotating element.

Install the seal spring.

Subassemble the outboard packing ring and stationary washer onto the stationary seat and press this subassembly into the seal liner.

Install the outboard rotating element.

Impeller Reassembly And Adjustment

(Figure 2)

If the impeller wear ring (23) was removed, position the wear ring on the impeller and tap lightly and evenly around the circumference with a block of wood or rubber mallet until the outer edge of the wear ring is flush with the face of the impeller.

Install the same number of impeller adjusting shims (29) as previously removed and screw the impeller on the shaft until tight.

It is necessary to maintain enough clearance between the impeller and the seal plate to prevent rubbing or binding. Add or subtract impeller shims until this clearance is reached.

Suction Head Installation

(Figure 2)

If the suction head wear ring (22) was removed, position the wear ring on the suction head with the chamfered side toward the suction head. Tap lightly and evenly around the circumference with a block of wood or rubber mallet until the wear ring bottoms out against the bore in the suction head.

Install the suction head and gasket (20) using the previously removed hardware (26). **Be careful** not to damage either of the wear rings (22 and 23) when positioning the suction head.

Secure the suction head to the base with the previously removed hardware (19, 20 and 21, Figure 1).

Final Pump Reassembly

Be sure the pump end assembly is secure to the engine and base.

Install the suction and discharge lines and open all valves in the lines. Make certain that all piping connections are tight and properly supported.

Be sure the pump and engine have been properly lubricated, see **LUBRICATION**.

Before starting refer to **OPERATION**, Section C, and start the pump.

LUBRICATION

Seal Assembly

Fill the grease cup through the grease fitting with a good grade of No. 2 lithium base grease until grease escapes from the relief hole. Turn the grease cup arm

counterclockwise until it is at the top of the stem; this will release the spring to apply grease to the seal (see Figure 5).

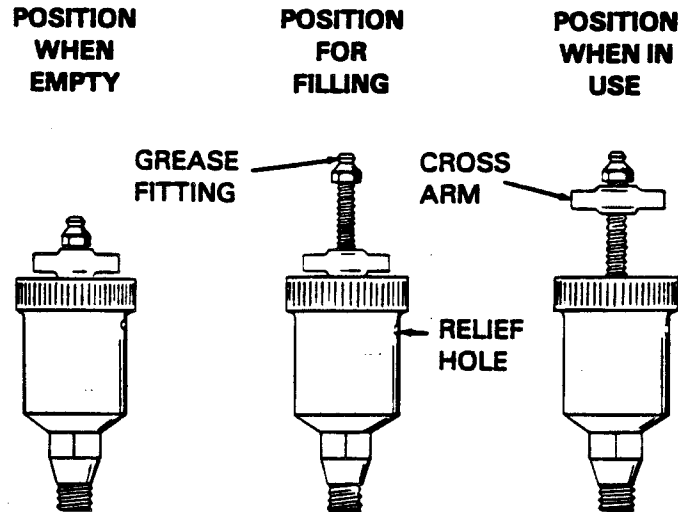

Figure 5. Automatic Lubricating Grease Cup

Bearings

The intermediate bearing cavity was fully lubricated when shipped from the factory. When additional lubrication is required, add one shot of No. 0 pressure gun grease to the grease fitting (10). **Do not over lubricate.** Excessive grease can cause overheating and reduce bearing life.

There are no provisions in the bearing cavity to drain or flush the lubricant. The pump must be disassembled to completely clean and maintain this cavity.

When lubricating a dry (overhauled) intermediate, fill the cavity through the grease fitting with 1/6 lb. of grease (approximately one-third full).

Under normal conditions, change the grease each 5000 hours of operation, or at 12 month intervals, whichever occurs first. In extremely dirty or humid conditions, change more frequently.

For cold weather operation, consult the factory or a lubricant supplier for the recommended grade of grease.

Engine

Consult the literature supplied with the engine, or contact your local engine representative.

**For U.S. and International Warranty Information,
Please Visit www.grpumps.com/warranty
or call:
U.S.: 419-755-1280
International: +1-419-755-1352**

**For Canadian Warranty Information,
Please Visit www.grcanada.com/warranty
or call:
519-631-2870**