

**INSTALLATION, OPERATION, PARTS LIST,
AND MAINTENANCE MANUAL**



G

January 22, 1981

**Portable
Engine Driven
Centrifugal
Fire-fighter Pump
Model 61 1/2 DP (FS)**

The title text is overlaid on a large, stylized outline of the fire-fighter pump. The outline shows the main body of the pump, a handle on the left side, and a hose connection on the right side. The text is in a bold, sans-serif font, with the words 'Portable', 'Engine Driven', 'Centrifugal', and 'Fire-fighter Pump' stacked vertically, and 'Model 61 1/2 DP (FS)' at the bottom.

THE GORMAN-RUPP COMPANY • MANSFIELD, OHIO

GORMAN-RUPP OF CANADA LIMITED • ST. THOMAS, ONTARIO, CANADA Printed in U.S.A.

Copyright by the Gorman-Rupp Company



This Installation, Operation, and Maintenance Manual is designed specifically to help you get the best performance and longest life from your Gorman-Rupp pump.

This pump is a 60 Series, enclosed impeller, centrifugal model designed for straight-in suction where the medium being pumped enters directly to the impeller eye.

If there are any questions regarding the pump which are not covered in this manual or in other literature accompanying the unit, please contact your Gorman-Rupp distributor, or write:

The Gorman-Rupp Company	or	Gorman-Rupp of Canada Limited
P.O. Box 1217		70 Burwell Road
Mansfield, Ohio 44902		St. Thomas, Ontario N5P 3R7

For information or technical assistance on the power source, contact the power source manufacturer's local dealer or representative.

The following are used to alert maintenance personnel to procedures which require special attention, to those which could damage equipment, and to those which could be dangerous to personnel:

NOTE

Instructions to aid in installation, operation, or maintenance or which clarify a procedure.

CAUTION

Instructions which must be followed to avoid causing damage to the product or other equipment incidental to the installation. These describe the procedure required and the damage which could result from failure to follow the procedure.

WARNING

Instructions which must be followed to avoid causing injury or death to personnel. These describe the procedure required and the injury which could result from failure to follow the procedure.

TABLE OF CONTENTS

WARNINGS	Section A
INSTALLATION	Section B
OPERATION	Section C
TROUBLESHOOTING	Section D
MAINTENANCE AND REPAIR	Section E
WARRANTY	

WARNINGS

THESE WARNINGS APPLY TO ENGINE DRIVEN PUMPS. REFER TO THE MANUAL ACCOMPANYING THE ENGINE BEFORE ATTEMPTING TO START THE ENGINE.

Before attempting to open or service the pump:

1. Familiarize yourself with this manual.
2. Remove or ground the spark plug to ensure that the pump will remain inoperative.
3. Drain the pump.

This pump has not been designed to pump volatile or corrosive materials.

Do not operate the pump against a closed discharge nozzle for long periods of time. This could bring the liquid to a boil, build pressure, and cause the pump to rupture.

Do not operate an internal combustion engine in an explosive atmosphere. When operating internal combustion engines in an enclosed area, make certain that exhaust fumes are piped to the outside. These fumes contain carbon monoxide, a deadly gas that is colorless, tasteless, and odorless.



Fuel used by internal combustion engines presents an extreme explosion and fire hazard. Make certain that all fuel lines are securely connected and free of leaks. Never refuel a hot or running engine. Avoid overfilling the fuel tank. Always use the correct type of fuel.

Never tamper with the governor to gain more power. The governor establishes safe operating limits that should not be exceeded.

INSTALLATION

Seldom are two pump installations identical. The information presented in this section is a summary of the recommended installation practices related to inspection, pump positioning, hardware, suction and discharge piping, and sumps. For further assistance, contact your Gorman-Rupp distributor or the Gorman-Rupp Company.

PREINSTALLATION INSPECTION

The pump assembly was inspected and tested before it was shipped from the factory. Before installation, inspect the pump for damage which may have occurred during shipment. Check as follows:

- a. Inspect the pump assembly for cracks, dents, damaged threads, and other obvious damage.
- b. Check for and tighten loose bolts, nuts, capscrews, and other attaching hardware. Since gaskets tend to shrink after drying, check for and tighten loose nuts and capscrews securing mating surfaces.
- c. Carefully read all tags, decals, and markings on the pump assembly, and perform all duties indicated. Note the direction of rotation indicated on the pump.
- d. Check engine lubricant levels, and lubricate the engine according to the engine manufacturer's recommendations.

POSITIONING THE PUMP

Mounting

Locate the pump in an accessible place as close as practical to the liquid to be pumped. Level mounting is essential for proper operation. The pump may have to be supported to provide for level operation or to eliminate vibration.

SUCTION AND DISCHARGE PIPING

Materials

Either pipe or hose may be used for suction and discharge lines, but hose used in suction lines must be the rigid-wall, reinforced type to prevent collapse under suction. Using pipe couplings in suction lines is not recommended.

Line Configuration

Keep suction and discharge lines as straight as possible to minimize friction losses. Make minimum use of elbows and fittings, which substantially increase friction loss. If elbows are necessary, use the long-radius type to minimize friction loss.

Gauges

Most pumps are drilled and tapped for installing discharge pressure and vacuum suction gauges. If these gauges are desired for pumps that are not tapped, drill and tap the suction and discharge lines close to the pump before installing the lines.



SUCTION LINES

To avoid air pockets which could affect pump priming, the suction line must be as short and direct as possible. When operation involves a suction lift, the line must always slope upward to the pump from the source of the liquid being pumped; if the line slopes down to the pump at any point along the suction run, air pockets will be created.

Fittings

Suction lines should be the same size as the pump inlet. If reducers are used in suction lines, they should be the eccentric type, and should be installed with the flat part of the reducers uppermost to avoid creating air pockets. Valves are not normally used in suction lines, but if a valve is used, install it with the stem horizontal to avoid air pockets.

Strainers

Install a strainer at the end of the suction line to avoid possible clogging or damage to the pump. The total area of the openings in the strainer should be at least three or four times the cross section of the suction line, but no opening should be larger than the solids handling capability of the pump. Clean the strainer regularly during operation.

Sealing

All connections in the suction line should be sealed with pipe dope to ensure an airtight seal. Even a slight leak will affect priming, head, and capacity, especially when operating with a high suction lift. After installation, inspect the suction line carefully for potential leaks.

DISCHARGE LINES

Do not terminate the discharge line at a level lower than that of the liquid being pumped unless a siphon breaker is used in the line. Otherwise, a siphoning action could result, causing damage to the pump.

Throttling Valves

If a throttling valve is desired, install it in the discharge line. Use a valve as large as the largest pipe in the line to minimize friction losses. Never install a throttling valve in the suction line.

SUCTION LINE POSITIONING

The depth of submergence of the suction line is critical to efficient pump operation. Figure 1 shows recommended minimum submergence vs. velocity.

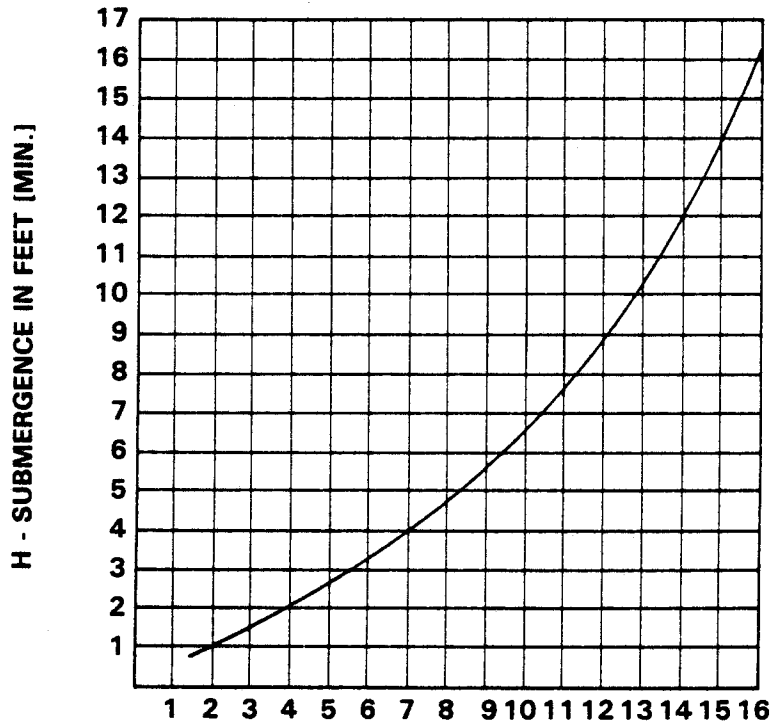

$$\text{VELOCITY IN FEET PER SEC.} = \frac{\text{QUAN. [G.P.M.] x .321}}{\text{AREA}} \text{ OR } \frac{\text{G.P.M. x .4085}}{D^2}$$

Figure 1. Recommended Minimum Suction Line Submergence Vs. Velocity



OPERATION

WARNING

This pump has not been designed to pump volatile or corrosive materials.

PRIMING

Install the pump and piping as described in INSTALLATION. Make sure that the piping connections are tight, and that the pump is securely mounted. Check that the pump is properly lubricated (see LUBRICATION in MAINTENANCE AND REPAIR).

This pump should never be operated unless there is liquid in the volute.

CAUTION

Never operate this pump unless the volute is filled with liquid. The pump will not prime when dry. Extended operation of a dry pump will destroy the seal assembly.

Add liquid to the volute housing:

1. When the pump is being put into service for the first time.
2. When the pump has not been used for a considerable length of time.
3. When the liquid in the volute housing has evaporated.

WARNING

After filling the volute housing, do not attempt to operate the pump unless all connecting piping is securely installed. Otherwise, liquid in the pump forced out under pressure could cause injury to personnel.

Hand-Operated Priming Pump

If this pump is equipped with a hand-operated vacuum priming pump, it is usually mounted directly on the pump and is designed to draw air out of the suction line and the volute.

Hand-operated priming pumps can be used while the pump is either stopped or operating.

If this pump is equipped with a discharge line throttling valve, close the throttling valve.

To prime the pump open the cock in the priming line. Operate the handle of the pump until liquid flows from the priming pump.

Once the pump is fully primed, close the cock in the priming line.

OPERATION

Leakage

No leakage should be visible at pump mating surfaces, or at pump connections or fittings. Keep all line connections and fittings tight to maintain maximum pumping efficiency.

Strainer Check

Check the suction strainer regularly during pump operation, or if the pump flow rate begins to drop.

Pump Vacuum Check

With the pump inoperative, install a vacuum gauge on the suction side of the pump, using pipe dope on the threads. Block the suction line and start the pump. At operating speed the pump should pull a vacuum of 20 inches or more of mercury. If it does not, check for air leaks in the seal or gasket.

Open the suction line, and read the vacuum gauge with the pump primed and at operating speed. Shut off the pump, and read the vacuum gauge again to determine if the vacuum remains at the maximum developed by the pump. If the vacuum falls off rapidly, an air leak exists; check to make certain that the air leak is not from the vacuum gauge connection.

Stopping

After stopping the pump, remove or ground the spark plug to ensure that the pump will remain inoperative.

In below-freezing conditions, a stopped pump should be drained, and any solids cleaned out by flushing with a hose, to prevent damage from freezing. After draining and flushing, operate the pump for approximately one minute to remove any remaining liquid that could freeze pump rotating parts.

In above-freezing conditions, a pump which has been idle for more than a few hours, or which has been pumping liquids containing solids, should be drained and flushed thoroughly. Operate the pump during the draining process.



TROUBLESHOOTING

WARNING

Before attempting to open or service the pump:

1. Consult pump service manual.
2. Remove or ground the spark plug to ensure that the pump will remain inoperative.
3. Drain pump.

Trouble	Possible Cause	Probable Remedy
PUMP FAILS TO PRIME	<p>Air leak in suction line.</p> <p>Lining of suction hose collapsed.</p> <p>Leaking or worn seal or pump gasket.</p> <p>Suction lift or discharge head too high.</p> <p>Suction strainer clogged.</p>	<p>Correct leak.</p> <p>Replace suction hose.</p> <p>Check pump vacuum. Replace leaking or worn seal or gasket.</p> <p>Check piping installation and install bypass line if needed. See INSTALLATION.</p> <p>Clean suction strainer.</p>
PUMP STOPS OR FAILS TO DELIVER RATED FLOW OR PRESSURE	<p>Air leak in suction line.</p> <p>Suction intake not submerged at proper level or sump too small.</p> <p>Lining of suction hose collapsed.</p> <p>Impeller or other wearing parts worn or damaged.</p> <p>Impeller clogged.</p> <p>Pump speed too slow.</p> <p>Suction lift too high.</p>	<p>Correct leak.</p> <p>Check installation and correct as needed. Check submergence chart (Section B)</p> <p>Replace suction hose.</p> <p>Check impeller clearance. Replace worn parts as needed.</p> <p>Free impeller of debris.</p> <p>Check engine output.</p> <p>Reduce suction lift.</p>

Trouble	Possible Cause	Probable Remedy
PUMP STOPS OR FAILS TO DELIVER RATED FLOW OR PRESSURE (cont)	Leaking or worn seal or pump gaskets.	Check pump vacuum. Replace leaking or worn seal or pump gaskets.
PUMP REQUIRES TOO MUCH POWER	Pump speed too high. Liquid solution too thick.	Check engine output. Dilute if possible.
EXCESSIVE NOISE	Cavitation in pump. Pumping entrained air. Pump or drive not securely mounted. Impeller clogged or damaged.	Reduce suction lift and/or friction losses in suction line. Locate and eliminate source of air bubble. Secure mounting hardware. Clean out debris; replace damaged parts.

Portable Engine Driven Centrifugal Fire-fighter Pump Model 61 $\frac{1}{2}$ DP (FS)

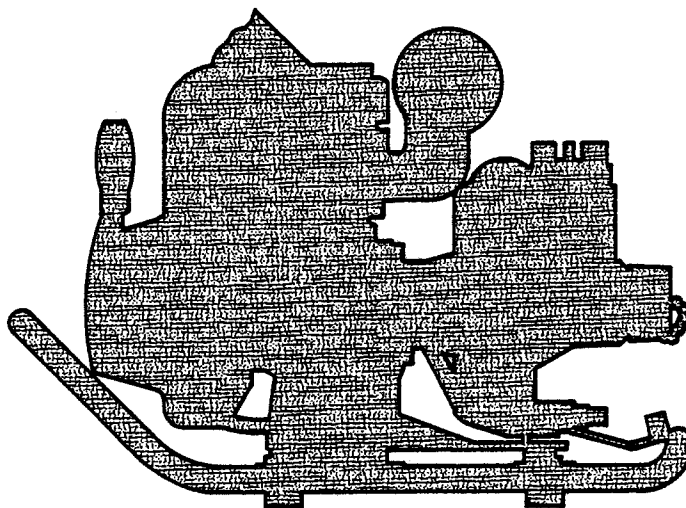

The only moving parts of this pump are the impeller, seal rotating elements, and the shaft. The wear rings, impeller, and seal, which receive the most wear, are easily accessible and can be replaced without disturbing the piping. Maintenance and replacement of these parts will maintain the peak operating efficiency of the pump.

UNIT ASSEMBLY

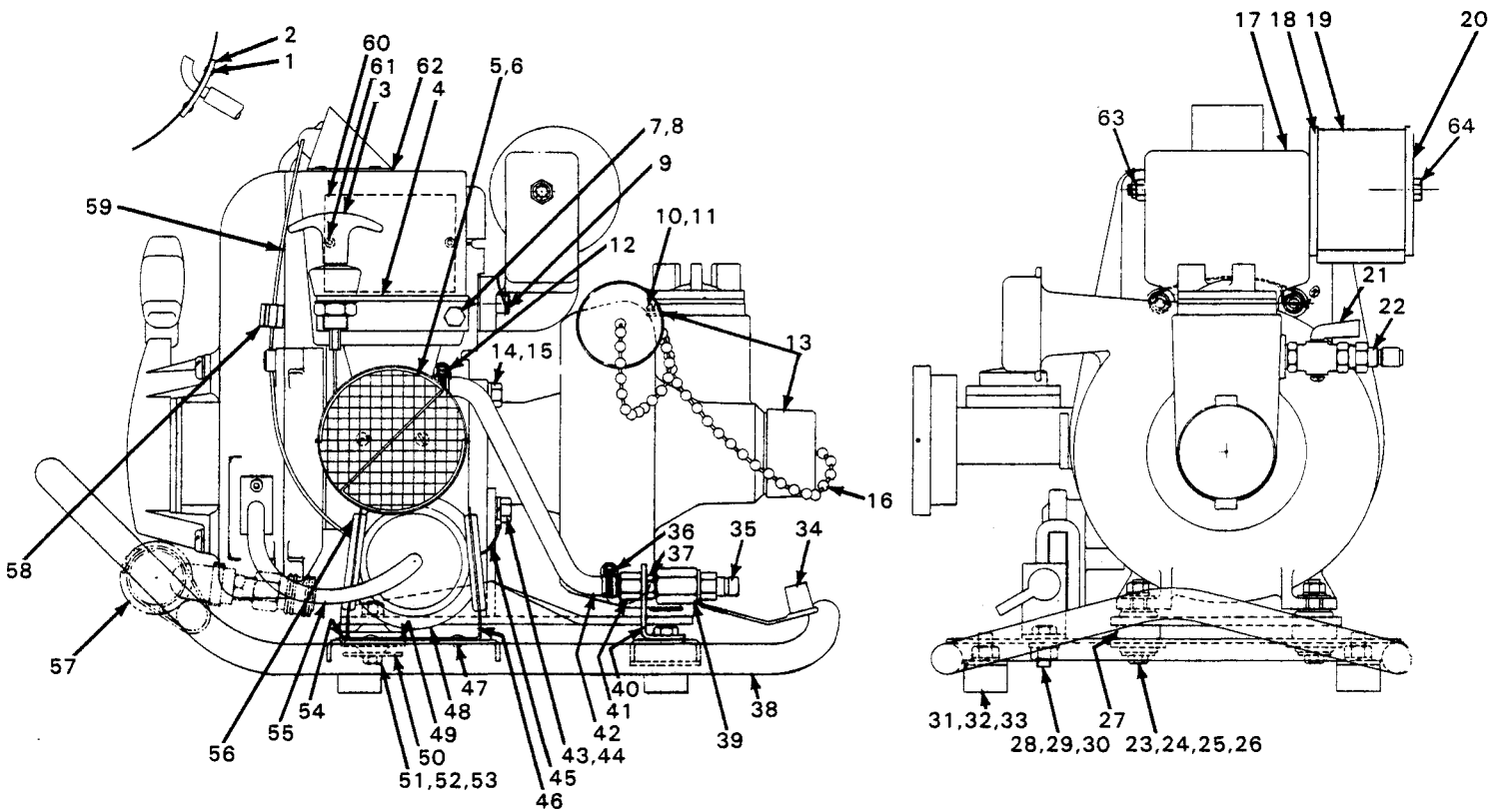

Figure 1. Pump Model 61 1/2 DP (FS)



PARTS LIST

PUMP MODEL 61 1/2 DP (FS)

(From S/N up)

ITEM NO.	PART NAME	PART NUMBER	MATL CODE	QTY	ITEM NO.	PART NAME	PART NUMBER	MATL CODE	QTY
1	POP RIVET	11703-A	13990	2	38	FRAME ASSEMBLY	11697	24004	1
2	ADAPTER ASSEMBLY	11699	24030	1	39	UNION	S-2082	-	1
3	THROTTLE CONTROL	11298-A	-	1	40	FUEL LINE BRACKET	11309	15991	1
4	THROTTLE BRACKET	11295-A	13135	1	41	HOSE STEM	S-2074	-	1
5	AIR CLEANER	S-2094	-	1	42	FUEL LINE 3/16 x 9	11308	-	1
6	RD HD MACHINE SCREW	22332-282	-	2	43	HEX HEAD CAPSCREW	B-0505	15991	2
7	LOCKWASHER	J-04	15991	2	44	LOCKWASHER	J-05	15991	2
8	HEX HEAD CAPSCREW	B-0404	15991	2	45	WIRE ASSEMBLY	11713	-	1
9	SOCKET HD CAPSCREW	21472-276	-	2	46	MOUNTING BRACKET	11723	15090	1
10	RD HD MACHINE SCREW	X#10-02-S	15991	1	47	POP RIVET	11703-A	13990	2
11	LOCKWASHER	J#10	15991	1	48	PRESSURE SWITCH	11691	-	1
12	HOSE CLAMP	26518-642	-	1	49	VIBRATION MOUNT	S-1785	-	1
13	PROTECTION CAP	11392	19220	2	50	SNUBBING WASHER	S-1786	-	1
14	HEX HEAD CAPSCREW	B-0504	15991	2	51	HEX HEAD CAPSCREW	B-0405	15991	1
15	LOCKWASHER	J-05	15991	2	52	LOCKWASHER	J-04	15991	1
16	BEAD CHAIN	11290-A	14990	2	53	HEX NUT	D-04	15991	1
17	MUFFLER	11291-A	13050	1	54	POP RIVET	11703-A	13990	4
18	SPARK ARREST BRACKET	14141	13005	1	55	FUEL LINE 3/16 x 6 1/2	11308-B	-	1
19	SPARK ARREST SCREEN	13346	17100	1	56	GROMMET	S-1792	-	2
20	SPARK ARRESTRON CAP	14142	13045	1	57	PRIMER ASSEMBLY	13347	-	1
21	SHUT-OFF VALVE	S-0198	-	1	58	WIRE CLIP	21183-501	-	1
22	QUICK CONNECT PLUG	S-2096	-	1	59	CONNECTOR	S-1790	-	1
23	HEX HEAD CAPSCREW	B-0407	15991	2	60	NAME PLATE	2613-EA	13990	1
24	LOCKWASHER	J-04	15991	2	61	POP RIVET	11703	13990	2
25	FLAT WASHER	K-04	15991	6	62	CHRYSLER ENGINE	217-A1	-	1
26	HEX NUT	D-04	15991	2	63	DEFORMED LOCKNUT	DC-04	15990	1
27	VIBRATION MOUNT	S-1784	-	2	64	HEX HEAD CAPSCREW	21631-040	-	1
28	HEX HEAD CAPSCREW	B-0503	15991	1	NOT SHOWN:				
29	LOCKWASHER	J-05	15991	1		HOSE GASKET	1459	19100	1
30	HEX NUT	D-05	15991	1		WRENCH	11301	15991	1
31	RUBBER BUMPER	1325-B	24010	4		METALCAL	11411-A	00000	1
32	LOCKWASHER	J-05	15991	4		FUEL TANK	11424-A	-	1
33	HEX NUT	D-05	15991	4		STRAINER	S-1737	-	1
34	PROTECTION CAP	11393-B	19220	1		SPARK PLUG	S-1756	-	1
35	SELF-SEAL BUSHING	S-2071	-	1		START CORD	S-2224	-	1
36	HOSE CLAMP	26518-642	-	1	OPTIONAL:				
37	HALF UNION	S-0305	-	1		CARRYING HARNESS	S-1745-A	-	1

Above Serial Numbers Do Not Apply To Pumps Made In Canada.

CANADIAN SERIAL NO. AND UP

SECTIONAL DRAWING

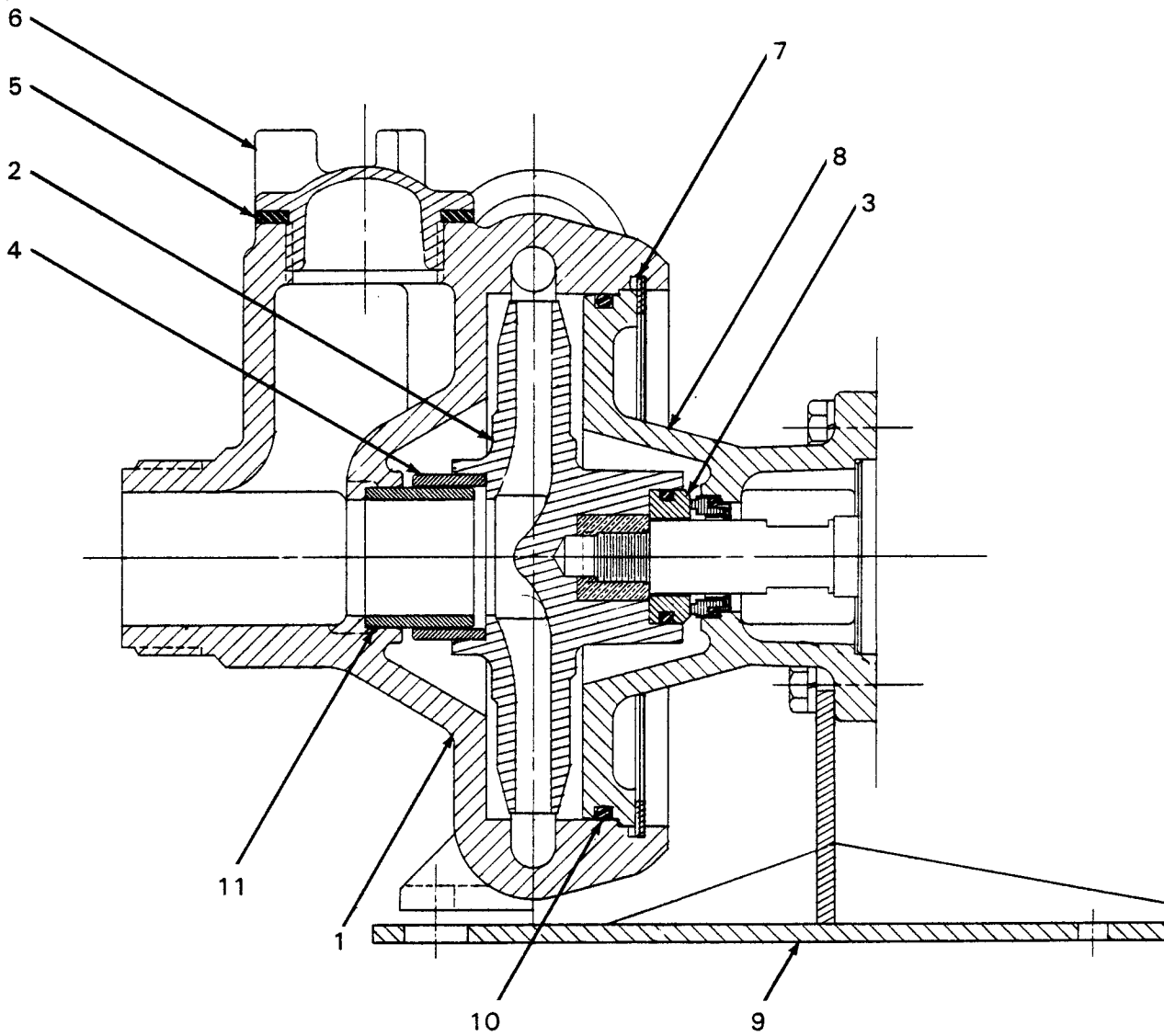

Figure 2. Pump Model 61½DP (FS)



PARTS LIST
PUMP MODEL 61 1/2 DP (FS)
(From S/N 423171 up)

ITEM NO.	PART NAME	PART NUMBER	MATL CODE	QTY
1	VOLUTE HOUSING	11288-A	1305E	1
2	★ IMPELLER	11287	13055	1
3	★ SEAL ASSEMBLY	S-1734		1
4	★ WEAR RING	11294	14050	1
5	★ FILL CAP GASKET	1322-G	19100	1
6	FILL CAP	1322	13055	1
7	RETAINING RING	S-1750		1
8	INTERMEDIATE BRACKET	11286-A	13055	1
9	MOUNTING BRACKET	11289-A	13135	1
10	★ INTERMEDIATE BRACKET O-RING	S-1733		1
11	★ WEAR RING	11293	14050	1

★ INDICATES PARTS RECOMMENDED FOR STOCK
 Above Serial Numbers Do Not Apply To Pumps Made In Canada.
CANADIAN SERIAL NO. AND UP

PUMP AND SEAL DISASSEMBLY AND REASSEMBLY

This pump requires little service due to its rugged, minimum-maintenance design. If it becomes necessary to inspect or replace components in and adjacent to the rotating assembly, however, follow these instructions, which are keyed to the sectional views (see figures 1 and 2) and the accompanying parts lists.

Pump Disassembly



WARNING

Before attempting to open or service the pump:

1. Familiarize yourself with this manual.
2. Disconnect the power source to ensure that the pump will remain inoperative.
3. Allow the pump to cool if overheated.
4. Vent the pump slowly and cautiously.
5. Close the suction and discharge valves.
6. Check the temperature before opening any covers, plates, or plugs.
7. Drain the pump.

Disconnect the power source, making certain that it will remain inoperative while the pump is being serviced, and close all connecting valves.

For access to the impeller (2, figure 2), and seal assembly (3), separate the volute housing (1) from the intermediate bracket (8).

Disengage hex nuts (26, figure 1) and remove the hex head capscrews (23) and washers (24 and 25) to disconnect the volute housing from the backpack frame (38).

Disengage snap ring (7, figure 2), securing the volute housing to the intermediate bracket and separate the assemblies. The impeller is now accessible.

To remove the impeller, immobilize it by inserting a pry bar or other suitable device between the vanes. Loosen the impeller by prying it in the direction of pump rotation; use caution not to damage the impeller vanes. Use caution when unscrewing the impeller from the shaft; tension on the seal spring will be released as the impeller is removed.

Seal Disassembly

Using a stiff wire with a hooked end if necessary, remove the seal components.

Clean the seal cavity with a soft cloth soaked in cleaning solvent.

WARNING

Most cleaning solvents are toxic and flammable. Use them only in a well-ventilated area free from excessive heat, sparks, and flame. Read and follow all precautions printed on solvent containers.

Seal Reassembly

The seal is not normally reused because of the high polish on its lapped faces, but if it is necessary to reuse the old seal, wash all metallic parts in cleaning solvent and dry thoroughly.

Inspect the seal components for wear, scoring, grooves, and other damage that might cause leakage. If any components are worn, replace the complete seal; never mix old and new seal parts.

CAUTION

This seal is not designed for operation at temperatures above 160°F. Do not use at higher operating temperatures.

See figure 3 for the correct order of installation of seal components.

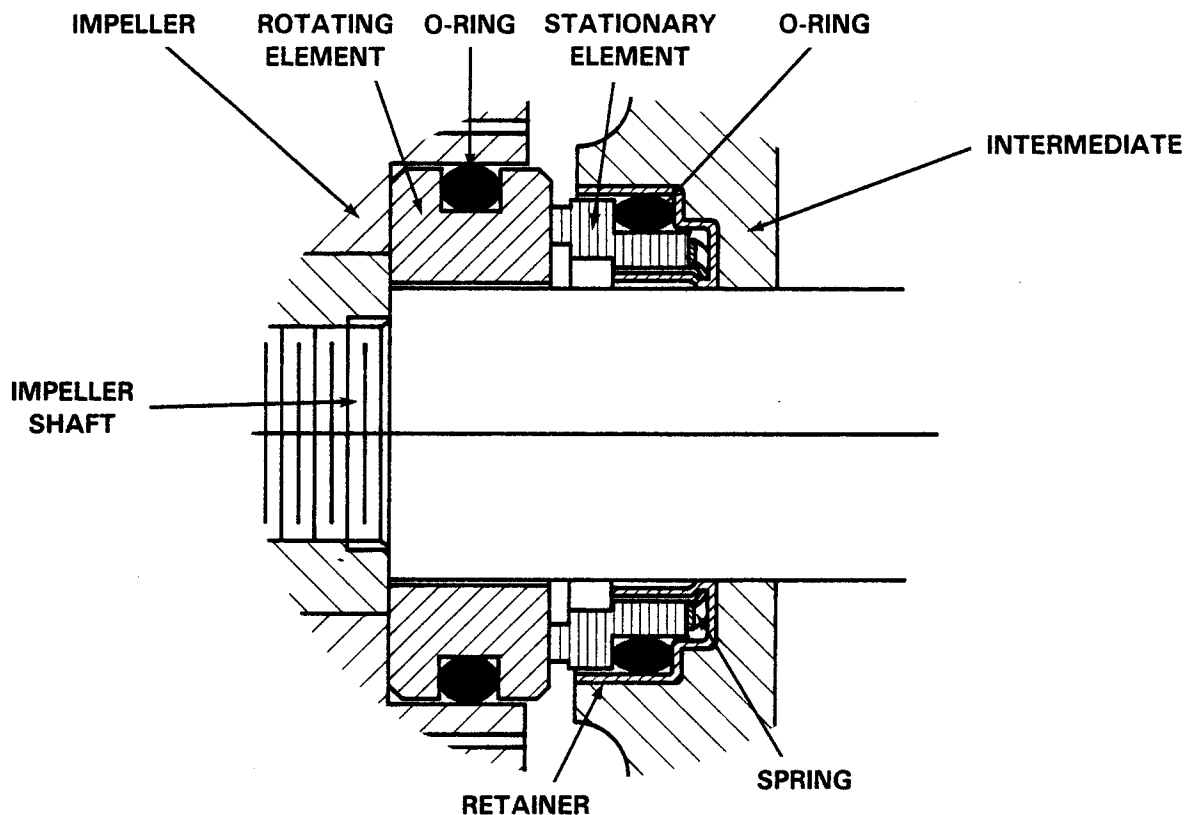

Figure 3. S-1734 Seal Assembly

Lubricate the rotating and stationary elements O-rings with soft grease or oil and install them in their proper elements. Place a drop of light lubricating oil on the lapped faces of the seal, and install the seal components.

Pump Reassembly

For maximum pump efficiency the impeller must be centered with the volute scroll.

Inspect the impeller, and replace it if cracked or badly worn. Secure the impeller on the shaft, making certain that all the seal components are seated squarely.

Inspect the impeller wear ring (4), which is a press fit in the impeller and inspect wear ring (11), which is a press fit in the volute housing. Replace them if cracked or badly worn.

Replace the intermediate bracket O-ring (10). Lubricate it with soft grease or oil and install the O-ring in the intermediate.

Reassemble the volute housing to the intermediate bracket and secure the pump to the backpack frame.

When tightening the mounting hardware, loosen hex head capscrews (14, figure 1) securing the pump to the engine.

Press the pump bracket foot against the frame allowing the rubber vibration mount (27, figure 1) to bellow out between the bracket and the washer.

Tighten all the mounting hardware and the capscrews securing the pump to the engine.

Turn the shaft to check that the impeller rotates freely.

Remove fill cap (6, figure 2) and fill the volute with clean liquid and make certain that all piping is securely tightened before starting the pump.

LUBRICATION

Seal Assembly

The seal assembly is lubricated by the medium being pumped.

**For U.S. and International Warranty Information,
Please Visit www.grpumps.com/warranty
or call:
U.S.: 419-755-1280
International: +1-419-755-1352**

**For Canadian Warranty Information,
Please Visit www.grcanada.com/warranty
or call:
519-631-2870**