

**INSTALLATION, OPERATION, PARTS LIST,  
AND MAINTENANCE MANUAL**

---

A C E G



January 22, 1981

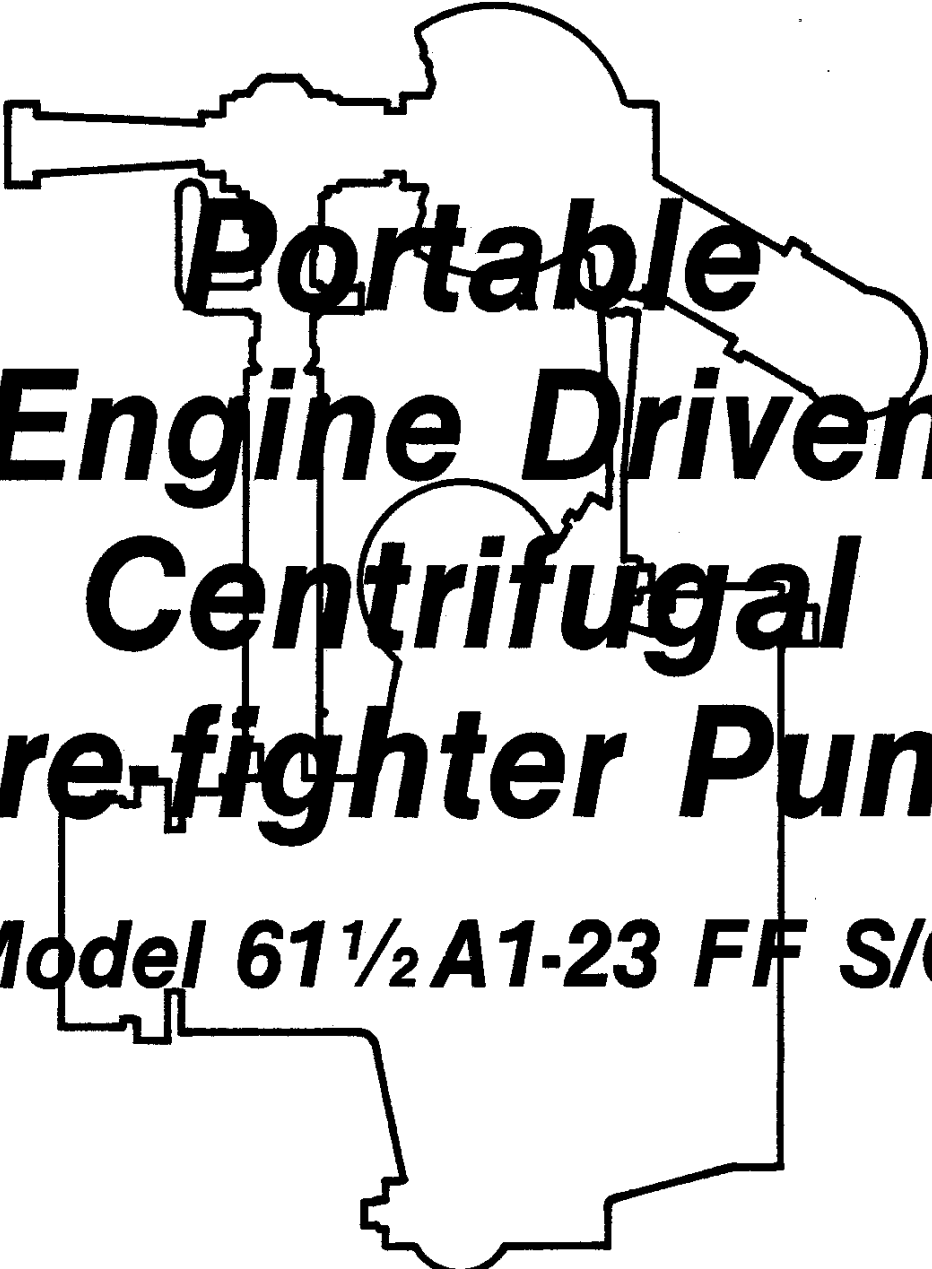

***Portable  
Engine Driven  
Centrifugal  
Fire-fighter Pump  
Model 61½ A1-23 FF S/G***

The central graphic is a large, bold outline drawing of a fire-fighter pump. The pump has a cylindrical body with various ports and a handle on top. The text is overlaid on this drawing.

**THE GORMAN-RUPP COMPANY • MANSFIELD, OHIO**  
**GORMAN-RUPP OF CANADA LIMITED • ST. THOMAS, ONTARIO, CANADA** Printed in U.S.A.

Copyright by the Gorman-Rupp Company



This Installation, Operation, and Maintenance Manual is designed specifically to help you get the best performance and longest life from your Gorman-Rupp pump.

This pump is a 60 Series, enclosed impeller, centrifugal model designed for straight-in suction where the medium being pumped enters directly to the impeller eye.

If there are any questions regarding the pump which are not covered in this manual or in other literature accompanying the unit, please contact your Gorman-Rupp distributor, or write:

The Gorman-Rupp Company	or	Gorman-Rupp of Canada Limited
P.O. Box 1217		70 Burwell Road
Mansfield, Ohio 44902		St. Thomas, Ontario N5P 3R7

For information or technical assistance on the power source, contact the power source manufacturer's local dealer or representative.

The following are used to alert maintenance personnel to procedures which require special attention, to those which could damage equipment, and to those which could be dangerous to personnel:

**NOTE**

Instructions to aid in installation, operation, or maintenance or which clarify a procedure.

**CAUTION**

Instructions which must be followed to avoid causing damage to the product or other equipment incidental to the installation. These describe the procedure required and the damage which could result from failure to follow the procedure.

**WARNING**

Instructions which must be followed to avoid causing injury or death to personnel. These describe the procedure required and the injury which could result from failure to follow the procedure.

**TABLE OF CONTENTS**

WARNINGS	Section A
INSTALLATION	Section B
OPERATION	Section C
TROUBLESHOOTING	Section D
MAINTENANCE AND REPAIR	Section E
WARRANTY	



## WARNINGS

THESE WARNINGS APPLY TO ENGINE DRIVEN PUMPS. REFER TO THE MANUAL ACCOMPANYING THE ENGINE BEFORE ATTEMPTING TO START THE ENGINE.

Before attempting to open or service the pump:

1. Familiarize yourself with this manual.
2. Remove or ground the spark plug to ensure that the pump will remain inoperative.
3. Drain the pump.

This pump has not been designed to pump volatile or corrosive materials.

Do not operate the pump against a closed discharge nozzle for long periods of time. This could bring the liquid to a boil, build pressure, and cause the pump to rupture.

Do not operate an internal combustion engine in an explosive atmosphere. When operating internal combustion engines in an enclosed area, make certain that exhaust fumes are piped to the outside. These fumes contain carbon monoxide, a deadly gas that is colorless, tasteless, and odorless.



Fuel used by internal combustion engines presents an extreme explosion and fire hazard. Make certain that all fuel lines are securely connected and free of leaks. Never refuel a hot or running engine. Avoid overfilling the fuel tank. Always use the correct type of fuel.

Never tamper with the governor to gain more power. The governor establishes safe operating limits that should not be exceeded.



## INSTALLATION

Seldom are two pump installations identical. The information presented in this section is a summary of the recommended installation practices related to inspection, pump positioning, hardware, suction and discharge piping, and sumps. For further assistance, contact your Gorman-Rupp distributor or the Gorman-Rupp Company.

### PREINSTALLATION INSPECTION

The pump assembly was inspected and tested before it was shipped from the factory. Before installation, inspect the pump for damage which may have occurred during shipment. Check as follows:

- a. Inspect the pump assembly for cracks, dents, damaged threads, and other obvious damage.
- b. Check for and tighten loose bolts, nuts, capscrews, and other attaching hardware. Since gaskets tend to shrink after drying, check for and tighten loose nuts and capscrews securing mating surfaces.
- c. Carefully read all tags, decals, and markings on the pump assembly, and perform all duties indicated. Note the direction of rotation indicated on the pump.
- d. Check engine lubricant levels, and lubricate the engine according to the engine manufacturer's recommendations.

### POSITIONING THE PUMP

#### Mounting

Locate the pump in an accessible place as close as practical to the liquid to be pumped. Level mounting is essential for proper operation. The pump may have to be supported to provide for level operation or to eliminate vibration.

### SUCTION AND DISCHARGE PIPING

#### Materials

Either pipe or hose may be used for suction and discharge lines, but hose used in suction lines must be the rigid-wall, reinforced type to prevent collapse under suction. Using pipe couplings in suction lines is not recommended.

#### Line Configuration

Keep suction and discharge lines as straight as possible to minimize friction losses. Make minimum use of elbows and fittings, which substantially increase friction loss. If elbows are necessary, use the long-radius type to minimize friction loss.

#### Gauges

Most pumps are drilled and tapped for installing discharge pressure and vacuum suction gauges. If these gauges are desired for pumps that are not tapped, drill and tap the suction and discharge lines close to the pump before installing the lines.



## **SUCTION LINES**

To avoid air pockets which could affect pump priming, the suction line must be as short and direct as possible. When operation involves a suction lift, the line must always slope upward to the pump from the source of the liquid being pumped; if the line slopes down to the pump at any point along the suction run, air pockets will be created.

### **Fittings**

Suction lines should be the same size as the pump inlet. If reducers are used in suction lines, they should be the eccentric type, and should be installed with the flat part of the reducers uppermost to avoid creating air pockets. Valves are not normally used in suction lines, but if a valve is used, install it with the stem horizontal to avoid air pockets.

### **Strainers**

Install a strainer at the end of the suction line to avoid possible clogging or damage to the pump. The total area of the openings in the strainer should be at least three or four times the cross section of the suction line, but no opening should be larger than the solids handling capability of the pump. Clean the strainer regularly during operation.

### **Sealing**

All connections in the suction line should be sealed with pipe dope to ensure an airtight seal. Even a slight leak will affect priming, head, and capacity, especially when operating with a high suction lift. After installation, inspect the suction line carefully for potential leaks.

## **DISCHARGE LINES**

Do not terminate the discharge line at a level lower than that of the liquid being pumped unless a siphon breaker is used in the line. Otherwise, a siphoning action could result, causing damage to the pump.

### **Throttling Valves**

If a throttling valve is desired, install it in the discharge line. Use a valve as large as the largest pipe in the line to minimize friction losses. Never install a throttling valve in the suction line.

**SUCTION LINE POSITIONING**

The depth of submergence of the suction line is critical to efficient pump operation. Figure 1 shows recommended minimum submergence vs. velocity.

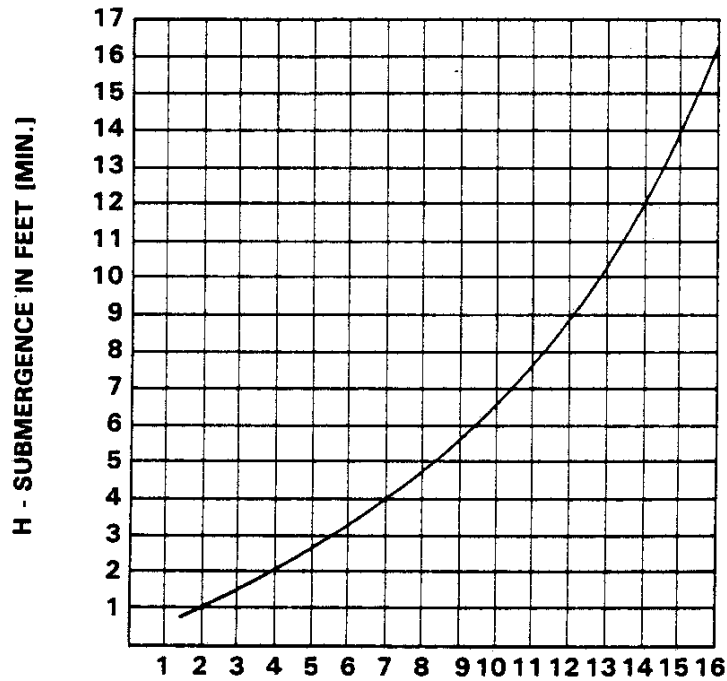

$$\text{VELOCITY IN FEET PER SEC.} = \frac{\text{QUAN. [G.P.M.] x .321}}{\text{AREA}} \text{ OR } \frac{\text{G.P.M. x .4085}}{D^2}$$

Figure 1. Recommended Minimum Suction Line Submergence Vs. Velocity







## OPERATION

### WARNING

This pump has not been designed to pump volatile or corrosive materials.

### PRIMING

Install the pump and piping as described in INSTALLATION, and make sure that the piping connections are tight. Check that the engine is properly lubricated.

To prime the pump, set the exhaust primer valve handle in the closed position, and open the gas cock in the volute housing exhaust primer line.

Start the engine in accordance with the engine manufacturer's instructions.

When there is a continuous discharge of liquid from the exhaust primer venturi, open the exhaust primer valve, and close the gas cock in the volute housing exhaust primer line.

### OPERATION

#### Leakage

No leakage should be visible at pump mating surfaces, or at pump connections or fittings. Keep all line connections and fittings tight to maintain maximum pumping efficiency.

#### Strainer Check

Check the suction strainer regularly during pump operation, or if the pump flow rate begins to drop.

#### Pump Vacuum Check

With the pump inoperative, install a vacuum gauge on the suction side of the pump, using pipe dope on the threads. Block the suction line and start the pump. At operating speed the pump should pull a vacuum of 20 inches or more of mercury. If it does not, check for air leaks in the seal or gasket.

Open the suction line, and read the vacuum gauge with the pump primed and at operating speed. Shut off the pump, and read the vacuum gauge again to determine if the vacuum remains at the maximum developed by the pump. If the vacuum falls off rapidly, an air leak exists; check to make certain that the air leak is not from the vacuum gauge connection.

#### Stopping

After stopping the pump, remove or ground the spark plug to ensure that the pump will remain inoperative.



In below-freezing conditions, a stopped pump should be drained, and any solids cleaned out by flushing with a hose, to prevent damage from freezing. After draining and flushing, operate the pump for approximately one minute to remove any remaining liquid that could freeze pump rotating parts.

In above-freezing conditions, a pump which has been idle for more than a few hours, or which has been pumping liquids containing solids, should be drained and flushed thoroughly. Operate the pump during the draining process.



## TROUBLESHOOTING

### WARNING

Before attempting to open or service the pump:

1. Consult pump service manual.
2. Remove or ground the spark plug to ensure that the pump will remain inoperative.
3. Drain pump.

Trouble	Possible Cause	Probable Remedy
PUMP FAILS TO PRIME	<p>Air leak in suction line.</p> <p>Lining of suction hose collapsed.</p> <p>Leaking or worn seal or pump gasket.</p> <p>Suction lift or discharge head too high.</p> <p>Suction strainer clogged.</p>	<p>Correct leak.</p> <p>Replace suction hose.</p> <p>Check pump vacuum. Replace leaking or worn seal or gasket.</p> <p>Check piping installation and install bypass line if needed. See INSTALLATION.</p> <p>Clean suction strainer.</p>
PUMP STOPS OR FAILS TO DELIVER RATED FLOW OR PRESSURE	<p>Air leak in suction line.</p> <p>Suction intake not submerged at proper level or sump too small.</p> <p>Lining of suction hose collapsed.</p> <p>Impeller or other wearing parts worn or damaged.</p> <p>Impeller clogged.</p> <p>Pump speed too slow.</p> <p>Suction lift too high.</p>	<p>Correct leak.</p> <p>Check installation and correct as needed. Check submergence chart (Section B)</p> <p>Replace suction hose.</p> <p>Check impeller clearance. Replace worn parts as needed.</p> <p>Free impeller of debris.</p> <p>Check engine output.</p> <p>Reduce suction lift.</p>



Trouble	Possible Cause	Probable Remedy
PUMP STOPS OR FAILS TO DELIVER RATED FLOW OR PRESSURE (cont)	Leaking or worn seal or pump gaskets.	Check pump vacuum. Replace leaking or worn seal or pump gaskets.
PUMP REQUIRES TOO MUCH POWER	Pump speed too high. Liquid solution too thick.	Check engine output. Dilute if possible.
EXCESSIVE NOISE	Cavitation in pump. Pumping entrained air. Pump or drive not securely mounted. Impeller clogged or damaged.	Reduce suction lift and/or friction losses in suction line. Locate and eliminate source of air bubble. Secure mounting hardware. Clean out debris; replace damaged parts.

# ***Portable Engine Driven Centrifugal Fire-fighter Pump Model 61<sup>1</sup>/<sub>2</sub> A1-23 FF S/G***

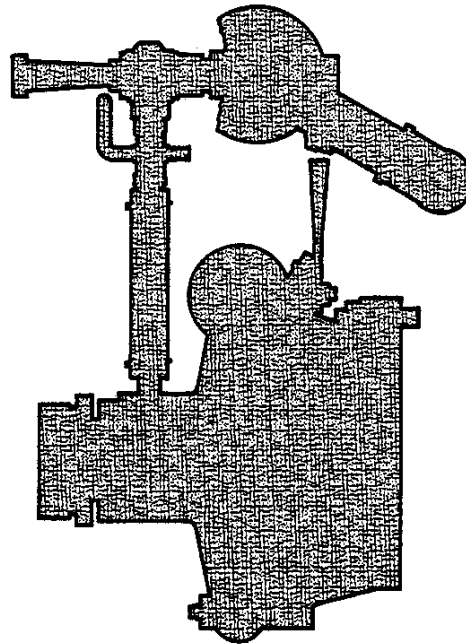

The only moving parts of this pump are the impeller, seal rotating elements, and the shaft. The wear ring, impeller, and seal, which receive the most wear, are easily accessible and can be replaced without disturbing the piping. Maintenance and replacement of these parts will maintain the peak operating efficiency of the pump.

# SECTIONAL DRAWING

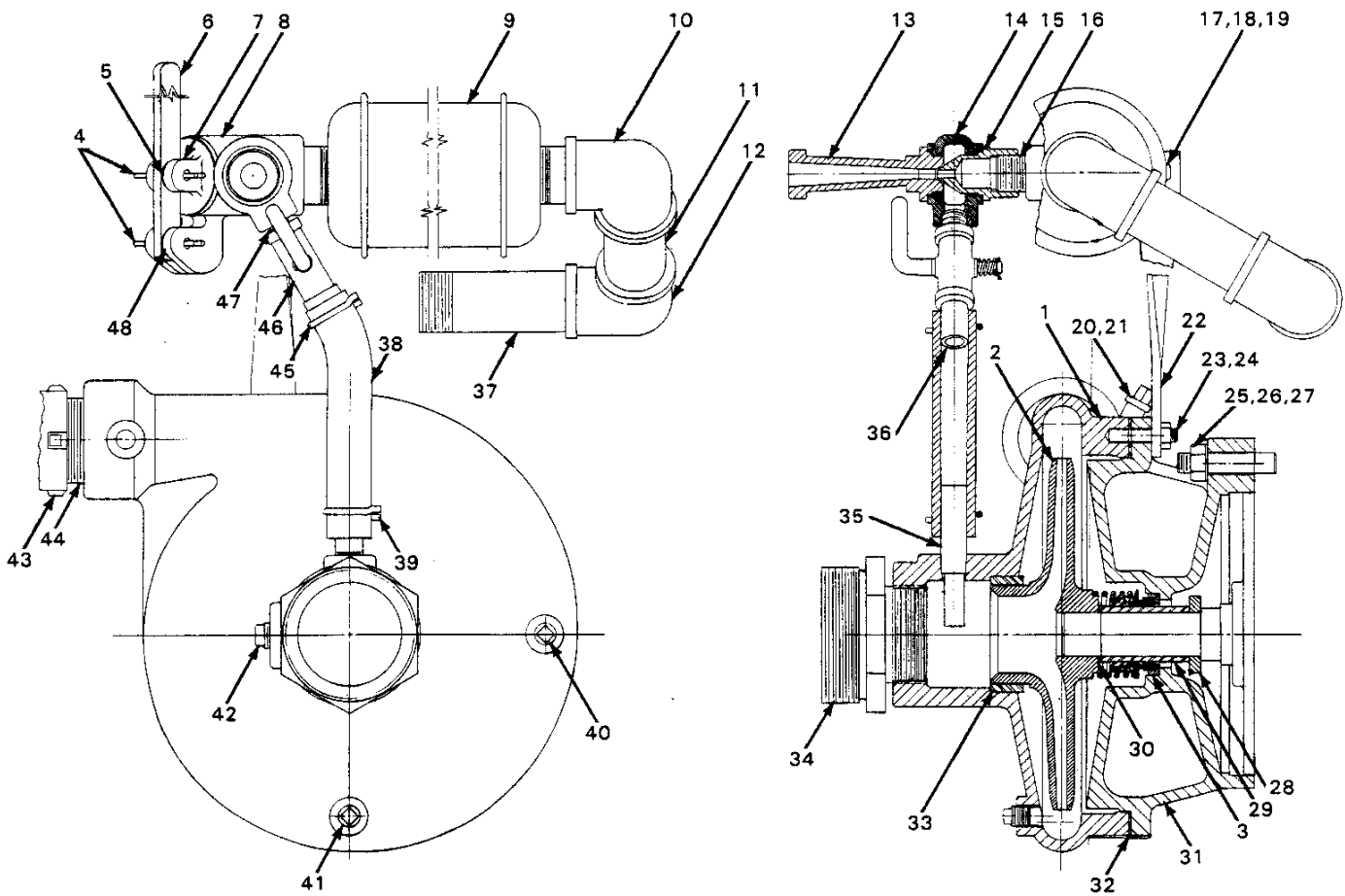

Figure 1. Pump Model 61 1/2 A1-23 FF S/G



# PARTS LIST

## PUMP MODEL 61½A1-23 FF S/G

(From S/N 558660 up)

ITEM NO.	PART NAME	PART NUMBER	MATL CODE	QTY	ITEM NO.	PART NAME	PART NUMBER	MATL CODE	QTY
1	VOLUTE HOUSING	5957	13040	1					
2	★IMPELLER	5956	13040	1		MOUNTING HARDWARE			
3	★SEAL ASSEMBLY	S-493	—	1		HEX HEAD CAPSCREW	B-0606	15991	4
4	COTTER PIN	M-0406	15990	2		HEX NUT	D-06	15991	4
5	SPRING WASHER	S-165	—	1		LOCKWASHER	J-06	15991	4
6	VALVE HANDLE	1458	15990	1		FLAT WASHER	K-06	15991	4
7	PRIMER VALVE CAP	1469	10010	1		STRAINER	2184-A	—	1
8	EXHAUST PRIMER VALVE	3643	10010	1		NAME PLATE	2613-BF	13990	1
9	MUFFLER	S-337	—	1		EXHAUST PRIMER TAG	6588-X	00000	1
10	PIPE ELBOW	R-16	11990	1		PRESSURE GAUGE	S-180	—	1
11	PIPE NIPPLE	T-1612	15070	1		EXHAUST PRIMER DECAL	6588-AS	00000	1
12	PIPE ELBOW	R-16	11990	1		CARRY HANDLE ASSY	44724-002	—	4
13	VENTURI	2345-A	14000	1		SPRING	6077	16030	4
14	EJECTOR BODY	3552	14000	1		HANDLE	6078	15070	4
15	EJECTOR JET	3645-A	14000	1		POSITION LOCK	11680	12030	4
16	PIPE NIPPLE	T-08	15070	1		MACHINE BOLT	A-0818	15991	4
17	HEX HEAD CAPSCREW	B-0604	15991	1		HEX NUT	D-08	15991	4
18	HEX NUT	D-06	15991	1		LOCKWASHER	AK-08	15991	4
19	LOCKWASHER	J-06	15991	1		JAM NUT	AT-08	15991	4
20	STREET ELBOW	AGS-04	11990	1		WIRE ASSEMBLY	5795-BG	—	1
21	PIPE PLUG	P-04	11990	1		WIRE ASSEMBLY	5795-BH	—	1
22	BRACKET	3647	15990	1		CABLE ASSEMBLY	5795-BJ	24040	1
23	STUD	C-0606	15991	8		CABLE ASSEMBLY	5795-BK	24040	1
24	HEX NUT	D-06	15991	8		WIRE ASSEMBLY	5795-BL	—	1
25	STUD	C-0709	15991	4		WIRE ASSEMBLY	5795-BM	—	1
26	HEX NUT	D-07	15991	4		BRACKET	8091	15990	1
27	LOCKWASHER	J-07	15991	4		REGULATOR BRACKET	11175	15990	1
28	★SEAL RING	2-A	15020	1		HEX HEAD CAPSCREW	B-0603	15991	4
29	★SHAFT SLEEVE	2146	14000	1		HEX NUT	D-04	15991	4
30	★IMPELLER ADJUST SHIMS	2-X	17090	1		HEX NUT	D-06	15991	4
31	INTERMEDIATE	5958	13040	1		LOCKWASHER	J-04	15991	4
32	★VOLUTE HOUSING GSKT	2958-G	18000	1		LOCKWASHER	J-06	15991	4
33	★WEAR RING	5978	10090	1		SWITCH	S-433	—	1
34	HOSE ADAPTER	5968	14000	1		AMMETER	S-810	—	1
35	NIPPLE	5769	—	1		RD HD MACHINE SCREW	X-0402	15991	4
36	PIPE NIPPLE	2434	15070	1		PAN HEAD TAPSCREW	BP#14-02	15990	4
37	PIPE NIPPLE	T-1616	15070	1		BATTERY BOX ASSEMBLY	GRP40-05	—	1
38	HOSE	2435-H	19170	1		CABLE ASSEMBLY	5795-AS	24040	1
39	HOSE CLAMP	S-887	—	1		BATTERY BOX	11281	24000	1
40	PIPE PLUG	P-04	11990	1		BATTERY BOX COVER	11870	24000	1
41	VOLUTE HSNG DRN PLUG	P-04	11990	1		HEX HEAD CAPSCREW	B-0403	15991	1
42	PIPE PLUG	P-06	11990	1		HEX HEAD CAPSCREW	B-0503	15991	4
43	BALL TYPE VALVE	S-1002	—	1		HEX HEAD CAPSCREW	B-0504	15991	1
44	PIPE NIPPLE	T-24	15070	1		HEX NUT	D-04	15991	1
45	HOSE CLAMP	S-887	—	1		HEX NUT	D-05	15991	5
46	GAS COCK	S-2	—	1		LOCKWASHER	J-05	15991	5
47	PIPE NIPPLE	T-0606	15070	1		FLAT WASHER	K-04	15991	1
48	SPRING WASHER	S-165	—	1		FLAT WASHER	K-05	15991	1
	NOT SHOWN:					BATTERY	S-1680	—	1
	B & S 23 ENGINE	201-F2	—	1		OPTIONAL:			
	BASE	5530-B	24000	1		2 WHEEL	GRP30-18	—	1

★INDICATES PARTS RECOMMENDED FOR STOCK  
Above Serial Numbers Do Not Apply To Pumps Made In Canada.

CANADIAN SERIAL NO. . . . . AND UP





## PUMP AND SEAL DISASSEMBLY AND REASSEMBLY

This pump requires little service due to its rugged, minimum-maintenance design. If it becomes necessary to inspect or replace components in and adjacent to the rotating assembly, however, follow these instructions, which are keyed to the sectional view (see figure 1) and the accompanying parts list.

### Pump Disassembly

#### WARNING

Before attempting to open or service the pump:

1. Familiarize yourself with this manual.
2. Disconnect the power source to ensure that the pump will remain inoperative.
3. Allow the pump to cool if overheated.
4. Vent the pump slowly and cautiously.
5. Close the suction and discharge valves.
6. Check the temperature before opening any covers, plates, or plugs.
7. Drain the pump.

Disconnect the power source, making certain that it will remain inoperative while the pump is being serviced, and close all connecting valves.

Remove the volute housing drain plug (41) to drain the pump. Clean and reinstall the plug after the pump has been drained.

For access to the impeller (2) and seal assembly (3), loosen hose clamp (39) securing the priming hose (38) to the volute housing (1) and separate the line from the housing. Remove hex nuts (24) securing the volute and the intermediate (31) and separate the assemblies. The impeller is now accessible.

To remove the impeller, immobilize it by inserting a pry bar or other suitable device between the vanes, and loosen the impeller by prying it in the direction of pump rotation. Use caution not to damage the impeller vanes. Use caution when unscrewing the impeller from the shaft; tension on the seal spring will be released as the impeller is removed.

Remove the impeller adjusting shims (30). For ease of reassembly, tag and tie the shims, or measure and record their thickness.

**Seal Disassembly**

Remove the seal spring. Using a stiff wire with a hooked end if necessary, remove the remainder of the seal components, the shaft sleeve (29) and the seal ring (28).

Clean the seal cavity and the shaft with a soft cloth soaked in cleaning solvent.

**WARNING**

Most cleaning solvents are toxic and flammable. Use them only in a well-ventilated area free from excessive heat, sparks, and flame. Read and follow all precautions printed on solvent containers.

**Seal Reassembly**

The seal is not normally reused because of the high polish on its lapped faces, but if it is necessary to reuse the old seal, wash all metallic parts in cleaning solvent and dry thoroughly.

Inspect the seal components for wear, scoring, grooves, and other damage that might cause leakage. If any components are worn, replace the complete seal; never mix old and new seal parts.

**CAUTION**

This seal is not designed for operation at temperatures above 160°F. Do not use at higher operating temperatures.

See figure 2 for the correct order of installation of seal components.

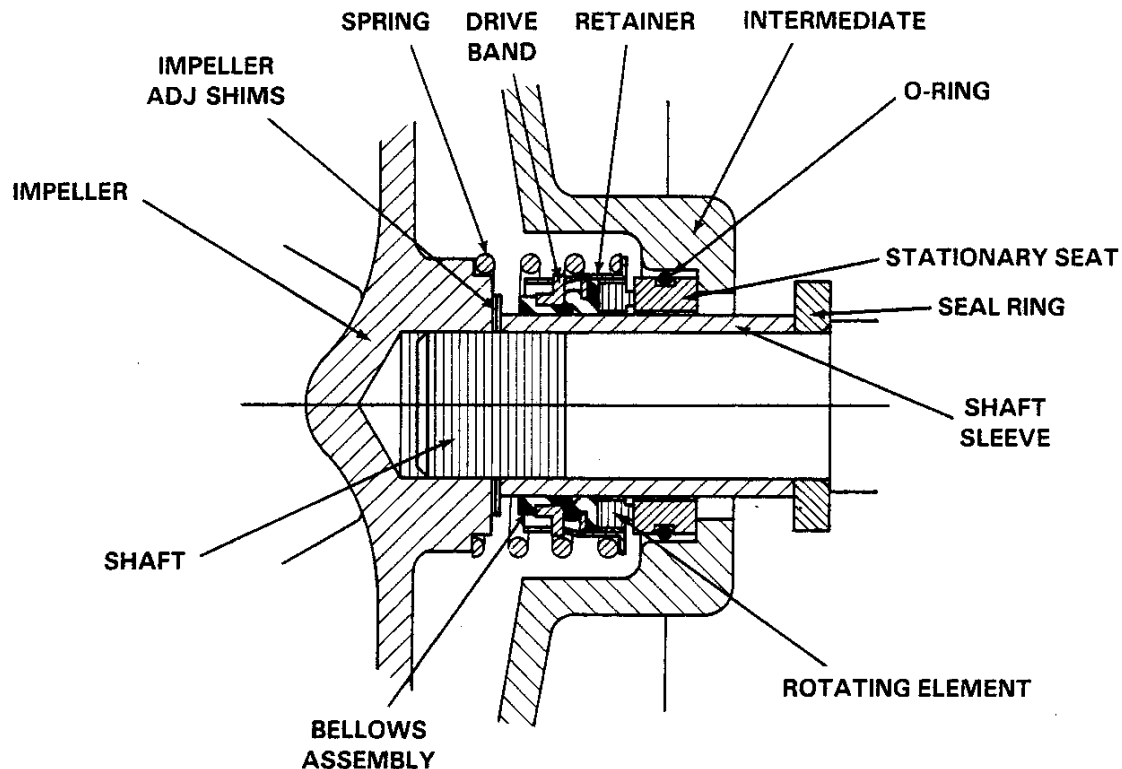

Figure 2. S-493 Seal Assembly

Clean and polish the seal ring and shaft sleeve, or replace them if there are nicks or cuts on the end; reinstall the seal ring and shaft sleeve.

Install the stationary seat. Place a drop of light lubricating oil on the lapped faces of the seal, and install the stationary and rotating elements. Lubricate the bellows with soft grease or oil and install the bellows assembly. Install the seal spring, making certain that all components of the seal are seated squarely.

#### Pump Reassembly

For maximum pump efficiency, the impeller must be centered in the volute scroll.

Install the impeller adjusting shims. If the same number and thickness of shims are reinstalled as were removed, the impeller should be centered with the volute scroll.

Inspect the impeller, and replace it if cracked or badly worn. Install and block the impeller, and turn the shaft until the impeller is secure.

Inspect the volute housing wear ring (33) and replace it if cracked or badly worn.

Replace the volute housing gasket (32) and reassemble the volute housing and the intermediate, securing the attaching hex nuts.



Turn the shaft to check that the impeller rotates freely. If it does not, add or remove additional shims until the impeller rotates freely when the pump is completely assembled.

Reconnect the priming line to the volute, securing the hose clamp. Make certain that all piping is securely tightened before starting the pump.

## **LUBRICATION**

### **Seal Assembly**

The seal assembly is lubricated by the medium being pumped.

**For U.S. and International Warranty Information,  
Please Visit [www.grpumps.com/warranty](http://www.grpumps.com/warranty)**

**or call:**

**U.S.: 419-755-1280**

**International: +1-419-755-1352**

**For Canadian Warranty Information,  
Please Visit [www.grcanada.com/warranty](http://www.grcanada.com/warranty)**

**or call:**

**519-631-2870**

**THE GORMAN-RUPP COMPANY • MANSFIELD, OHIO**

**GORMAN-RUPP OF CANADA LIMITED • ST. THOMAS, ONTARIO, CANADA**