

**INSTALLATION, OPERATION,
AND MAINTENANCE MANUAL**
WITH PARTS LIST



50 SERIES PUMP

MODEL
53H2-B

THE GORMAN-RUPP COMPANY • MANSFIELD, OHIO

www.grpumps.com

GORMAN-RUPP OF CANADA LIMITED • ST. THOMAS, ONTARIO, CANADA Printed in U.S.A.

©2010 The Gorman-Rupp Company

Register your new
Gorman-Rupp pump online at
www.grpumps.com

Valid serial number and e-mail address required.

RECORD YOUR PUMP MODEL AND SERIAL NUMBER

Please record your pump model and serial number in the spaces provided below. Your Gorman-Rupp distributor needs this information when you require parts or service.

Pump Model: _____

Serial Number: _____

TABLE OF CONTENTS

INTRODUCTION	PAGE I – 1
SAFETY - SECTION A	PAGE A – 1
INSTALLATION – SECTION B	PAGE B – 1
Pump Dimensions	PAGE B – 1
PREINSTALLATION INSPECTION	PAGE B – 1
POSITIONING PUMP	PAGE B – 2
Lifting	PAGE B – 2
Mounting	PAGE B – 2
SUCTION AND DISCHARGE PIPING	PAGE B – 2
Materials	PAGE B – 2
Line Configuration	PAGE B – 2
Connections to Pump	PAGE B – 2
Gauges	PAGE B – 3
SUCTION LINES	PAGE B – 3
Fittings	PAGE B – 3
Strainers	PAGE B – 3
Sealing	PAGE B – 3
Suction Lines In Sumps	PAGE B – 3
Suction Line Positioning	PAGE B – 3
DISCHARGE LINES	PAGE B – 4
Siphoning	PAGE B – 4
Valves	PAGE B – 4
Bypass Lines	PAGE B – 4
ALIGNMENT	PAGE B – 5
Coupled Drives	PAGE B – 5
Drive Belts	PAGE B – 5
DRIVE BELT TENSIONING	PAGE B – 6
General Rules of Tensioning	PAGE B – 6
Tension Measurement	PAGE B – 6
OPERATION – SECTION C	PAGE C – 1
PRIMING	PAGE C – 1
Hand Primers	PAGE C – 1
Exhaust Primers	PAGE C – 1
Auxiliary Ejectors	PAGE C – 2
Vacuum Pumps	PAGE C – 2
STARTING	PAGE C – 2
Rotation	PAGE C – 2
OPERATION	PAGE C – 1
Leakage	PAGE C – 2
Liquid Temperature And Overheating	PAGE C – 2
Strainer Check	PAGE C – 3
Pump Vacuum Check	PAGE C – 3
STOPPING	PAGE C – 3
Cold Weather Preservation	PAGE C – 3
BEARING TEMPERATURE CHECK	PAGE C – 4

TABLE OF CONTENTS
(continued)

TROUBLESHOOTING – SECTION D	PAGE D – 1
PUMP MAINTENANCE AND REPAIR - SECTION E	PAGE E – 1
STANDARD PERFORMANCE CURVE	PAGE E – 1
PARTS LIST:	
Pump Model	PAGE E – 3
PUMP AND SEAL DISASSEMBLY AND REASSEMBLY	PAGE E – 4
Cover Plate Removal	PAGE E – 4
Impeller Removal	PAGE E – 4
Pump Casing, Wear Ring and Seal Removal	PAGE E – 5
Shaft and Bearing Removal and Disassembly	PAGE E – 5
Shaft and Bearing Reassembly And Installation	PAGE E – 6
Pump Casing, Wear Ring and Seal Installation	PAGE E – 8
Impeller Installation	PAGE E – 10
Cover Plate Installation	PAGE E – 10
Final Pump Assembly	PAGE E – 10
LUBRICATION	PAGE E – 11
Bearings	PAGE E – 11
Seal Assembly	PAGE E – 11
Power Source	PAGE E – 11

INTRODUCTION

Thank You for purchasing a Gorman-Rupp pump. **Read this manual** carefully to learn how to safely install and operate your pump. Failure to do so could result in personal injury or damage to the pump.

This pump is a 50 Series, basic centrifugal model with an enclosed impeller. The pump is designed for handling clean liquids at high heads and high discharge pressures. The basic material of construction is gray iron, with gray iron impeller and wear ring.

Because pump installations are seldom identical, this manual cannot possibly provide detailed instructions and precautions for every aspect of each specific application. Therefore, it is the responsibility of the owner/installer of the pump to ensure that applications not addressed in this manual are performed **only** after establishing that neither operator safety nor pump integrity are compromised by the installation. Pumps and related equipment **must** be installed and operated according to all national, local and industry standards.

If there are any questions regarding the pump or its application which are not covered in this manual or in other literature accompanying this unit, please contact your Gorman-Rupp distributor, or:

The Gorman-Rupp Company
P.O. Box 1217
Mansfield, Ohio 44901-1217
Phone: (419) 755-1011
 or:
Gorman-Rupp of Canada Limited
70 Burwell Road
St. Thomas, Ontario N5P 3R7
Phone: (519) 631-2870

For information or technical assistance on the power source, contact the power source manufacturer's local dealer or representative.

The following are used to alert maintenance personnel to procedures which require special attention, to those which could damage equipment, and to those which could be dangerous to personnel:



Immediate hazards which WILL result in severe personal injury or death. These instructions describe the procedure required and the injury which will result from failure to follow the procedure.



Hazards or unsafe practices which COULD result in severe personal injury or death. These instructions describe the procedure required and the injury which could result from failure to follow the procedure.



Hazards or unsafe practices which COULD result in minor personal injury or product or property damage. These instructions describe the requirements and the possible damage which could result from failure to follow the procedure.

NOTE

Instructions to aid in installation, operation, and maintenance or which clarify a procedure.

SAFETY - SECTION A

This information applies to 50 Series basic pumps. Gorman-Rupp has no control over or particular knowledge of the power source which will be used. Refer to the manual accompanying the power source before attempting to begin operation.

This manual will alert personnel to known procedures which require special attention, to those which could damage equipment, and to those which could be dangerous to personnel. However, this manual cannot possibly provide detailed instructions and precautions for each specific application or for every situation that might occur during maintenance of the unit. Therefore, it is the responsibility of the owner, installer and/or maintenance personnel to ensure that applications and/or maintenance procedures not addressed in this manual are performed only after establishing that neither personal safety nor pump integrity are compromised by such applications or procedures.



Before attempting to open or service the pump:

1. Familiarize yourself with this manual.
2. Disconnect or lock out the power source to ensure that the pump will remain inoperative.
3. Allow the pump to completely cool if overheated.
4. Check the temperature before opening any covers, plates, or plugs.
5. Close the suction and discharge valves.

6. Vent the pump slowly and cautiously.
7. Drain the pump.



This pump is designed to handle clear liquids. Do not attempt to pump volatile, corrosive, or flammable materials which may damage the pump or endanger personnel as a result of pump failure.



Use lifting and moving equipment in good repair and with adequate capacity to prevent injuries to personnel or damage to equipment. Suction and discharge hoses and piping must be removed from the pump before lifting.



After the pump has been positioned, make certain that the pump and all piping connections are tight, properly supported and secure before operation.



Do not operate the pump without the guards in place over the rotating parts. Exposed rotating parts can catch clothing, fingers, or tools, causing severe injury to personnel.



Do not operate the pump against a closed discharge valve for long periods of time. If operated against a closed dis-

charge valve, pump components will deteriorate, and the liquid could come to a boil, build pressure, and cause the pump casing to rupture or explode.



Do not remove plates, covers, gauges, pipe plugs, or fittings from an overheated pump. Vapor pressure within the pump can cause parts being disengaged to be ejected with great force. Allow the pump to cool before servicing.



Overheated pumps can cause severe burns and injury. If overheating of the pump occurs:

1. Stop the pump immediately.
2. Allow the pump to completely cool.
3. Refer to instructions in this manual before restarting the pump.



Pumps and related equipment must be installed and operated according to all national, local and industry standards.

INSTALLATION – SECTION B

Review all SAFETY information in Section A.

Since pump installations are seldom identical, this section offers only general recommendations and practices required to inspect, position, and arrange the pump and piping.

Most of the information pertains to a standard **static lift** application where the pump is positioned above the free level of liquid to be pumped.

If installed in a **flooded suction application** where the liquid is supplied to the pump under pressure, some of the information such as mounting, line

configuration, and priming must be tailored to the specific application. This pump is equipped with a Gorman-Rupp double grease lubricated seal, therefore the maximum incoming pressure must be limited to 10 p.s.i.

For further assistance, contact your Gorman-Rupp distributor or the Gorman-Rupp Company.

Pump Dimensions

See Figure 1 for the approximate physical dimensions of this pump.

OUTLINE DRAWING

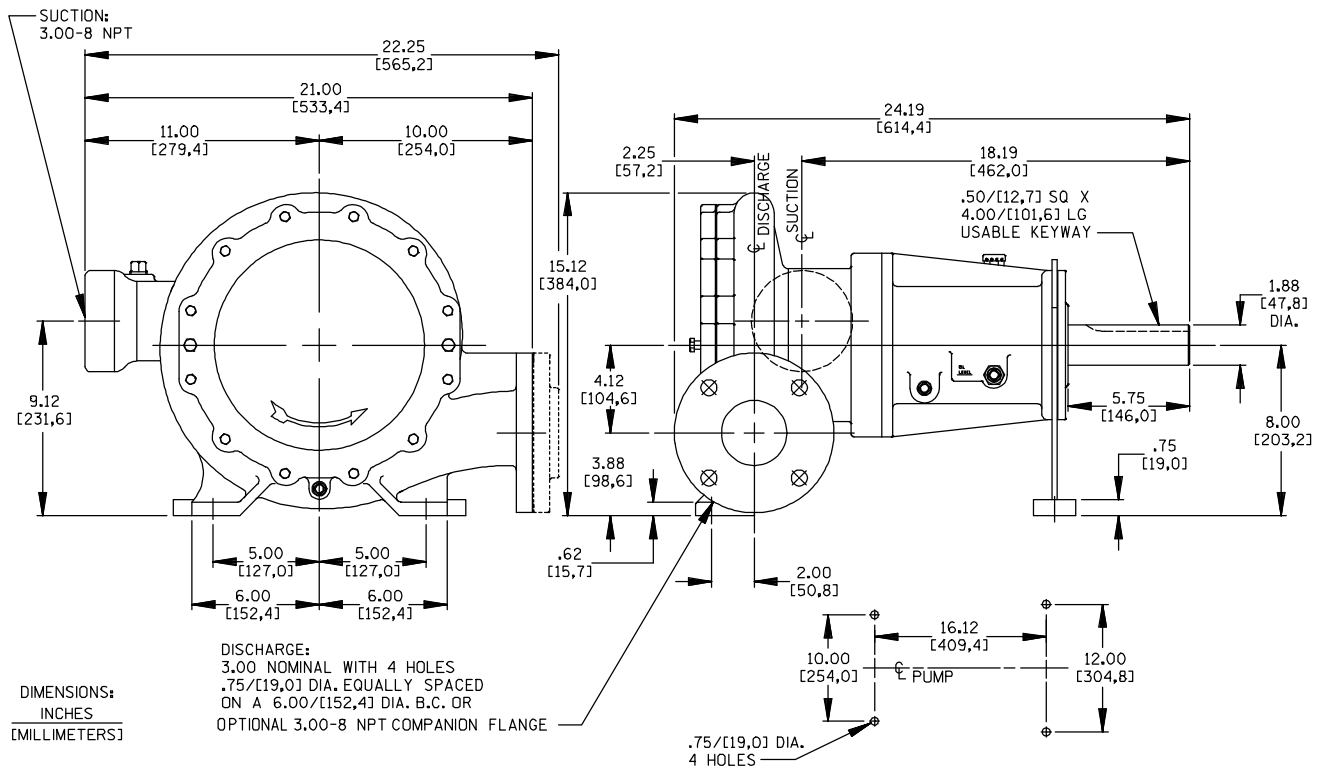

Figure 1. Pump Model 53H2-B

PREINSTALLATION INSPECTION

The pump assembly was inspected and tested before shipment from the factory. Before installation, inspect the pump for damage which may have occurred during shipment. Check as follows:

- a. Inspect the pump for cracks, dents, damaged threads, and other obvious damage.
- b. Check for and tighten loose attaching hardware. Since gaskets tend to shrink after drying, check for loose hardware at mating surfaces.

- c. Carefully read all tags, decals, and markings on the pump assembly, and perform all duties indicated.
- d. Check levels and lubricate as necessary. Refer to **LUBRICATION** in the **MAINTENANCE AND REPAIR** section of this manual and perform duties as instructed.
- e. Check to ensure the warning and caution stickers that were shipped loose with pump are included with the pump assembly. (Check Parts List in Section E for the itemized list.)
- f. If the pump has been stored for more than 12 months, some of the components or lubricants may have exceeded their maximum shelf life. These **must be inspected or replaced** to ensure maximum pump service.

If the maximum shelf life has been exceeded, or if anything appears to be abnormal, contact your Gorman-Rupp distributor or the factory to determine the repair or updating policy. **Do not** put the pump into service until appropriate action has been taken.

POSITIONING PUMP

Lifting

Pump unit weights will vary depending on the mounting and drive provided. Check the shipping tag on the unit packaging for the actual weight, and use lifting equipment with appropriate capacity. Drain the pump and remove all customer-installed equipment such as suction and discharge hoses or piping before attempting to lift existing, installed units.

Make sure that hoists and other lifting equipment are of sufficient capacity to safely handle the pump assembly. If chains and cables are used, make certain that they are positioned so that they will not damage the pump, and so that the load will be balanced.



The pump assembly can be seriously

damaged if the cables or chains used to lift and move the unit are improperly wrapped around the pump.

Mounting

Locate the pump in an accessible place as close as practical to the liquid being pumped. Level mounting is essential for proper operation.

The pump may have to be supported or shimmed to provide for level operation or to eliminate vibration.

If the pump has been mounted on a moveable base, make certain the base is stationary by setting the brake and blocking the wheels before attempting to operate the pump.

SUCTION AND DISCHARGE PIPING

Pump performance is adversely effected by increased suction lift, discharge elevation, and friction losses. See the performance curve and operating range shown on Page E-1 to be sure your overall application allows the pump to operate within the safe operation range.

Materials

Either pipe or hose maybe used for suction and discharge lines; however, the materials must be compatible with the liquid being pumped. If hose is used in suction lines, it must be the rigid-wall, reinforced type to prevent collapse under suction. Using piping couplings in suction lines is not recommended.

Line Configuration

Keep suction and discharge lines as straight as possible to minimize friction losses. Make minimum use of elbows and fittings, which substantially increase friction loss. If elbows are necessary, use the long-radius type to minimize friction loss.

Connections to Pump

Before tightening a connecting flange, align it exactly with the pump port. Never pull a pipe line into place by tightening the flange bolts and/or couplings.

Lines near the pump must be independently supported to avoid strain on the pump which could cause excessive vibration, decreased bearing life, and increased shaft and seal wear. If hose-type lines are used, they should have adequate support to secure them when filled with liquid and under pressure.

Gauges

Most pumps are drilled and tapped for installing discharge pressure and vacuum suction gauges. If these gauges are desired for pumps that are not tapped, drill and tap the suction and discharge lines not less than 18 inches (457,2 mm) from the suction and discharge ports and install the lines. Installation closer to the pump may result in erratic readings.

SUCTION LINES

To avoid air pockets which could affect pump priming, the suction line must be as short and direct as possible. When operation involves a suction lift, the line must always slope upward to the pump from the source of the liquid being pumped; if the line slopes down to the pump at any point along the suction run, air pockets will be created.

Fittings

Suction lines should be the same size as the pump inlet. If reducers are used in suction lines, they should be the eccentric type, and should be installed with the flat part of the reducers uppermost to avoid creating air pockets. Valves are not normally used in suction lines, but if a valve is used, install it with the stem horizontal to avoid air pockets.

Strainers

If a strainer is furnished with the pump, be certain to use it; any spherical solids which pass through a strainer furnished with the pump will also pass through the pump itself.

If a strainer is not furnished with the pump, but is installed by the pump user, make certain that the total area of the openings in the strainer is at least three or four times the cross section of the suction

line, and that the openings will not permit passage of solids larger than the solids handling capability of the pump.

This pump is designed to handle up to 11/32 inch (8,7 mm) diameter spherical solids.

Sealing

Since even a slight leak will affect priming, head, and capacity, especially when operating with a high suction lift, all connections in the suction line should be sealed with pipe dope to ensure an airtight seal. Follow the sealant manufacturer's recommendations when selecting and applying the pipe dope. The pipe dope should be compatible with the liquid being pumped.

Suction Lines In Sumps

If a single suction line is installed in a sump, it should be positioned away from the wall of the sump at a distance equal to 1 1/2 times the diameter of the suction line.

If there is a liquid flow from an open pipe into the sump, the flow should be kept away from the suction inlet because the inflow will carry air down into the sump, and air entering the suction line will reduce pump efficiency.

If it is necessary to position inflow close to the suction inlet, install a baffle between the inflow and the suction inlet at a distance 1-1/2 times the diameter of the suction pipe. The baffle will allow entrained air to escape from the liquid before it is drawn into the suction inlet.

If two suction lines are installed in a single sump, the flow paths may interact, reducing the efficiency of one or both pumps. To avoid this, position the suction inlets so that they are separated by a distance equal to at least 3 times the diameter of the suction pipe.

Suction Line Positioning

The depth of submergence of the suction line is critical to efficient pump operation. Figure 2 shows recommended minimum submergence vs. velocity.

NOTE

The pipe submergence required may be reduced

by installing a standard pipe increaser fitting at the end of the suction line. The larger opening size will reduce the inlet velocity. Calculate the required

submergence using the following formula based on the increased opening size (area or diameter).

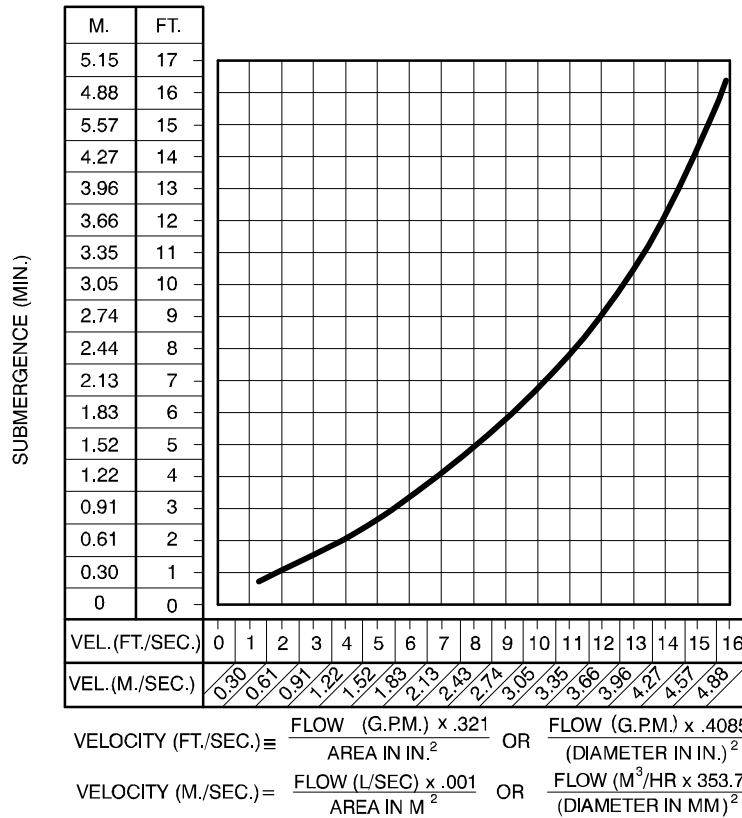

Figure 2. Recommended Minimum Suction Line Submergence vs. Velocity

DISCHARGE LINES

Siphoning

Do not terminate the discharge line at a level lower than that of the liquid being pumped unless a siphon breaker is used in the line. Otherwise, a siphoning action causing damage to the pump could result.

Valves

A check valve in the discharge line is normally recommended, but it is not necessary in low discharge head applications.

If a throttling valve is desired in the discharge line, use a valve as large as the largest pipe to minimize friction losses. Never install a throttling valve in a suction line.

With high discharge heads, it is recommended that a throttling valve and a system check valve be in-

stalled in the discharge line to protect the pump from excessive shock pressure and reverse rotation when it is stopped.

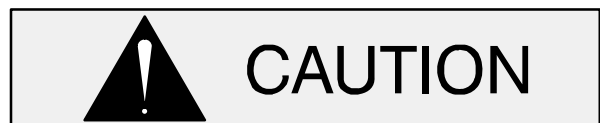

If the application involves a high discharge head, gradually close the discharge throttling valve before stopping the pump.

Bypass Lines

If it is necessary to permit the escape of air to atmosphere during initial priming or in the repriming cycle, install a bypass line (sized so that it will not affect pump discharge capacity) between the pump and the discharge check valve. Since this pump does not use a suction check valve, the discharge end of the bypass line must be submerged in the liquid being pumped in order to maintain suction.

ALIGNMENT

The alignment of the pump and its power source is critical for trouble-free mechanical operation. In either a flexible coupling or V-belt driven system, the driver and pump must be mounted so that their shafts are aligned with and parallel to each other. It is imperative that alignment be checked after the pump and piping are installed, and before operation.

NOTE

Check **Rotation**, Section C, before final alignment of the pump.

When mounted at the Gorman-Rupp factory, driver and pump are aligned before shipment. Misalignment will occur in transit and handling. Pumps **must** be checked and realigned before operation. Before checking alignment, tighten the foundation bolts. The pump casing feet and/or pedestal feet, and the driver mounting bolts should also be tightly secured.



When checking alignment, disconnect the power source to ensure that the pump will remain inoperative.



Adjusting the alignment in one direction may alter the alignment in another direction. Check each procedure after altering alignment.

Coupled Drives

When using couplings, the axis of the power source must be aligned to the axis of the pump shaft in both the horizontal and vertical planes. Most couplings require a specific gap or clearance between the driving and the driven shafts. Refer to the coupling manufacturer's service literature.

Align spider insert type couplings by using calipers to measure the dimensions on the circumference of the outer ends of the coupling hub every 90°. The coupling is in alignment when the hub ends are the same distance apart at all points (see Figure 3).

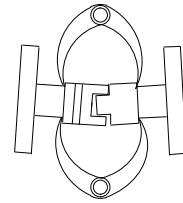

Figure 3. Aligning Spider-Type Couplings

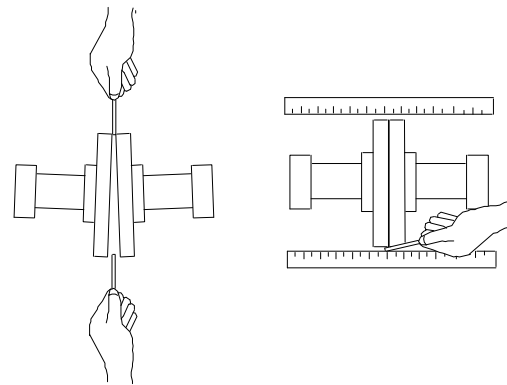

Figure 4. Aligning Non-Spider Type Couplings

Align non-spider type couplings by using a feeler gauge or taper gauge between the coupling halves every 90°. The coupling is in alignment when the hubs are the same distance apart at all points (see Figure 4).

Check parallel adjustment by laying a straightedge across both coupling rims at the top, bottom, and side. When the straightedge rests evenly on both halves of the coupling, the coupling is in horizontal parallel alignment. If the coupling is misaligned, use a feeler gauge between the coupling and the straightedge to measure the amount of misalignment.

Drive Belts

When using drive belts, the power source and the pump must be parallel. Use a straightedge along the sides of the pulleys to ensure that the pulleys are properly aligned (see Figure 5). In drive sys-

tems using two or more belts, make certain that the belts are a matched set; unmatched sets will cause accelerated belt wear.

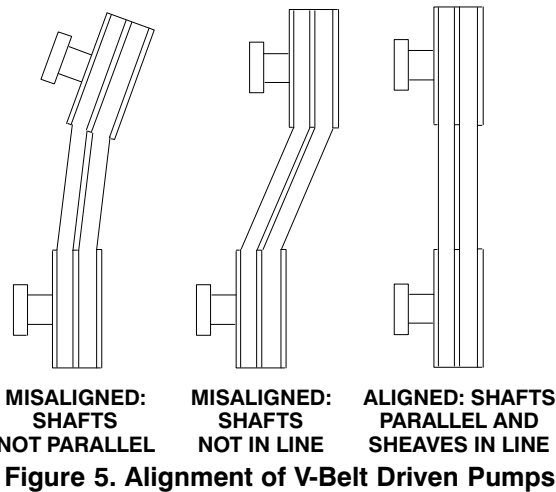

Tighten the belts in accordance with the belt manufacturer’s instructions. If the belts are too loose, they will slip; if the belts are too tight, there will be excessive power loss and possible bearing failure. Select pulleys that will match the proper speed ratio; overspeeding the pump may damage both pump and power source.



Do not operate the pump without the guard in place over the rotating parts. exposed rotating parts can catch clothing, fingers, or tools, causing severe injury to personnel.

DRIVE BELT TENSIONING

General Rules of Tensioning

For new drive belts, check the tension after 5, 20 and 50 hours of operation and re-tension as required (see the following procedure for measuring belt tension). Thereafter, check and re-tension if required monthly or at 500 hour intervals, whichever comes first.

Ideal drive belt tension is the **lowest** tension at which the belt will not slip under peak load conditions. Do not over-tension drive belts. Over-tensioning will shorten both drive belt and bearing life.

Under-tensioning will cause belt slippage. Always keep belts free from dirt, grease, oil and other foreign material which may cause slippage.

Tension Measurement

Correct v-belt tension can be achieved using a v-belt tension tester and Table 1 or 2. Use the tables to find the v-belt size (cross-section), the smallest sheave diameter, the belt type for your application. The corresponding deflection force required for new or used belts is shown opposite the RPM range of the pump.

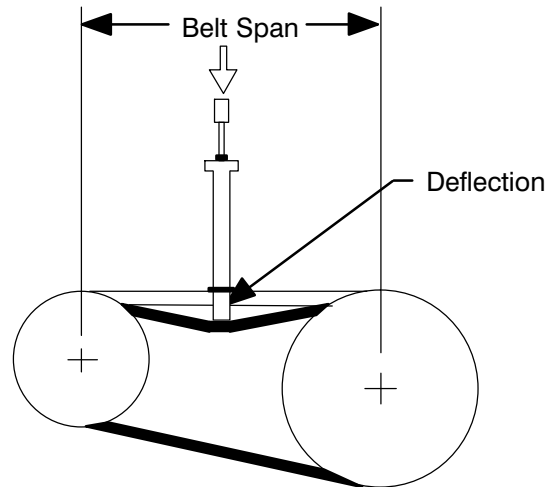

Figure 6. Belt Tension Measurement

The ratio of deflection to belt span is 1:64 for both ASA and metric units. Therefore, a belt with a span of 64 inches would require a deflection of 1 inch at the force shown on the Tables for your particular application.

For example, if the span as measured in Figure 6 is 32 inches (813 mm), the v-belt cross-section is C, the smallest sheave diameter is 8 inches, the pump speed is 1250 RPM, and the belts are uncogged Yy-T type, then 11.5 lbs. of force on the tensioner should show 1/2-inch (12,7 mm) of deflection.

A tension tester is available as an option from Gorman-Rupp (P/N 29513-001). Other tension testers are available from your local belt/sheave distributor, and work on a similar principal.

To use the Gorman-Rupp tensioner, measure the belt span as shown in Figure 6. Position the bottom of the large O-ring on the span scale of the tensioner at the measured belt span. Set the small O-ring on the deflection force scale to zero.

Place the tension tester squarely on the belt at the center of the belt span. Apply force on the plunger, perpendicular to the belt span, until the bottom of the large O-ring is even with the top of the next belt, or with the bottom of a straight edge laid across the sheaves.

Read the force applied from the bottom of the small

O-ring on the deflection force scale. Compare this force with the value shown in Table 1 or 2 and adjust the tension accordingly. Note that the **tension for new belts is higher than that for used belts** to allow for expected belt stretching. **Do not** over-tension used belts to the higher deflection forces shown for new belts.

**Table 1. Sheave Diameter (Inches)
Deflection Force (Lbs.)**

Cross Section	Smallest Sheave Diameter Range	R.P.M. Range	Belt Deflection Force			
			Uncogged Hy-T Belts & Uncogged Hy-T Torque Team		Cogged Torque-Flex & Machined Edge torque Team Belts	
			Used Belt	New Belt	Used Belt	New Belt
A,AX	3.0 - 3.6	1000-2500 2501-4000	3.7 2.8	5.5 4.2	4.1 3.4	6.1 5.0
	3.8 - 4.8	1000-2500 2501-4000	4.5 3.8	6.8 5.7	5.0 4.3	7.4 6.4
	5.0 - 7.0	1000-2500 2501-4000	5.4 4.7	8.0 7.0	5.7 5.1	9.4 7.4
B,BX	3.4 - 4.2	860-2500 2501-4000			4.9 4.2	7.2 6.2
	4.4 - 5.6	860-2500 2501-4000	5.3 4.5	7.9 6.7	7.1 7.1	10.5 9.1
	5.8 - 8.6	860-2500 2501-4000	6.3 6.0	9.4 8.9	8.5 7.3	12.6 10.9
C,CX	7.0 - 9.0	500-1740 1741-3000	11.5 9.4	17.0 13.8	14.7 11.9	21.8 17.5
	9.5 - 16.0	500-1740 1741-3000	14.1 12.5	21.0 18.5	15.9 14.6	23.5 21.6
D	12.0 - 16.0	200-850 851-1500	11.5 9.4	17.0 13.8	14.7 11.9	21.8 17.5
	18.0 - 20.0	200-850 851-1500	30.4 25.6	45.2 38.0		
3V, 3VX	2.2 - 2.4	1000-2500 2501-4000			3.3 2.9	4.9 4.3
	2.65 - 3.65	1000-2500 2501-4000	3.6 3.0	5.1 4.4	4.2 3.8	6.2 5.6
	4.12 - 6.90	1000-2500 2501-4000	4.9 4.4	7.3 6.6	5.3 4.9	7.9 7.3
5V, 5VX	4.4 - 6.7	500-1749 1750-3000 3001-4000			10.2 8.8 5.6	15.2 13.2 8.5
	7.1 - 10.9	500-1740 1741-3000	12.7 11.2	18.9 16.7	14.8 13.7	22.1 20.1
	11.8 - 16.0	500-1740 1741-3000	15.5 14.6	23.4 21.8	17.1 16.8	25.5 25.0
8V	12.5 - 17.0	200-850 851-1500	33.0 26.8	49.3 39.9		
	18.0 - 22.4	200-850 851-1500	39.6 35.3	59.2 52.7		

**Table 2. Sheave Diameter (Millimeters)
Deflection Force (KG.)**

Cross Section	Smallest Sheave Diameter Range	R.P.M. Range	Belt Deflection Force			
			Uncogged Hy-T Belts & Uncogged Hy-T Torque Team		Cogged Torque-Flex & Machined Edge torque Team Belts	
			Used Belt	New Belt	Used Belt	New Belt
A,AX	75 - 90	1000-2500 2501-4000	1.7 1.3	2.5 1.9	1.9 1.5	2.8 2.3
	91 - 120	1000-2500 2501-4000	2.0 1.7	3.1 2.6	2.3 2.0	3.4 2.9
	125 - 175	1000-2500 2501-4000	2.4 2.1	3.6 3.2	2.6 2.3	4.3 3.4
B,BX	85 - 105	860-2500 2501-4000			2.2 1.9	3.3 2.8
	106 - 140	860-2500 2501-4000	2.4 2.0	3.6 3.0	3.2 3.2	4.8 4.1
	141 - 220	860-2500 2501-4000	2.9 2.7	4.3 4.0	3.9 3.3	5.7 4.9
C,CX	175 - 230	500-1740 1741-3000	5.2 4.3	7.7 6.3	6.7 5.4	9.9 7.9
	231 - 400	500-1740 1741-3000	6.4 5.7	9.5 8.4	7.2 6.6	10.7 9.8
D	305 - 400	200-850 851-1500	11.3 9.6	16.8 14.2		
	401 - 510	200-850 851-1500	13.8 11.6	20.5 17.2		
3V, 3VX	55 - 60	1000-2500 2501-4000			1.5 1.3	2.2 2.0
	61 - 90	1000-2500 2501-4000	1.6 1.4	2.3 2.0	1.9 1.7	2.8 2.5
	91 - 175	1000-2500 2501-4000	2.2 2.0	3.3 3.0	2.4 2.2	3.6 3.3
5V, 5VX	110 - 170	500-1749 1750-3000 3001-4000			4.6 4.0 2.5	6.9 6.0 3.9
	171 - 1275	500-1740 1741-3000	5.8 5.1	8.6 7.6	6.7 6.2	10.0 9.1
	276 - 400	500-1740 1741-3000	7.0 6.6	10.6 9.9	7.8 7.6	11.6 11.3
8V	315 - 430	200-850 851-1500	15.0 12.2	22.4 18.1		
	431 - 570	200-850 851-1500	18.0 16.0	26.8 23.9		

OPERATION – SECTION C

Review all **SAFETY** information in Section A.

Follow the instructions on all tags, labels and decals attached to the pump.



This pump is designed to handle liquids containing specified entrained solids. Do not attempt to pump volatile, corrosive, or flammable liquids which may damage the pump or endanger personnel as a result of pump failure.

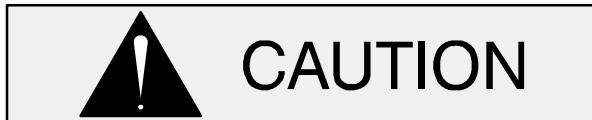

Pump speed and operating conditions must be within the performance range shown on page E-1.

PRIMING

Install the pump and piping as described in **INSTALLATION**. Make sure that the piping connections are tight, and that the pump is securely mounted. Check that the pump is properly lubricated (see **LUBRICATION** in **MAINTENANCE AND REPAIR**).

This is not a self-priming pump, so an external priming device must be used if the pump is installed on a **suction lift**. A foot valve may be installed at the end of the suction pipe to maintain the prime; however, this may adversely affect pump performance due to friction loss. Many standard centrifugal models are equipped with a hand-operated vacuum pump, exhaust primer, or ejector for this purpose. If a priming device was not furnished with the pump, it may be ordered from the factory as an option. Before attempting to operate the priming device, close the discharge throttling valve. (Installation of a spring-loaded check valve is also recommended to facilitate priming.) Once the pump is fully primed, close the valve between

the priming device and pump to preserve the prime. Start the pump and open the discharge valve slowly to fill the discharge line. When installed in a **flooded suction** application, simply open the system valves and permit the incoming liquid to evacuate the air. After the pump and piping system have completely filled, evacuate any remaining air pockets in the pump or suction line.

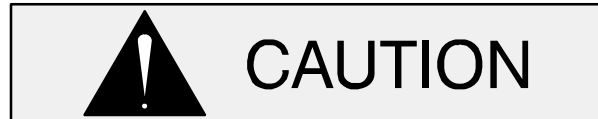

Never operate this pump unless there is liquid in the pump casing. The pump will not prime when dry. Extended operation of a dry pump will destroy the seal assembly.

Hand Primers

Hand-operated primers are usually mounted on the pump and, when operated, draw air out of the suction line and pump casing. To prime a pump with a hand vacuum pump, open the cock on the pump priming line. Operate the hand pump until liquid flows out of the check valve on the bottom of the primer pump. Once the pump is primed, close the valve located between the primer and the pump so that the prime will not be lost.

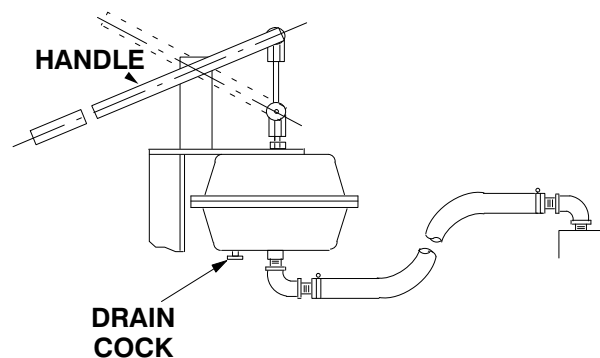

Figure 1. Hand Primer Assembly

Exhaust Primers

Engine driven pumps normally take advantage of the engine exhaust gases by using them to operate an exhaust primer. The exhaust is directed through

a venturi which creates a vacuum in the pump casing in order to fill the suction line and pump casing with liquid. To prime a pump using an exhaust primer, open the gas cock in the priming line and engage the exhaust primer until liquid is thrown out of the ejector nozzle.

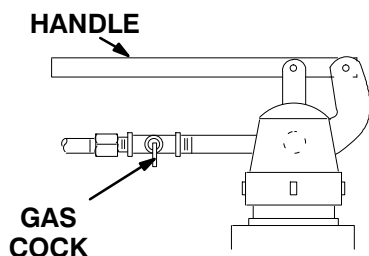

Figure 2. Exhaust Primer Assembly

Air can be exhausted to prime a pump by using a vacuum pump. Either a wet type or a dry type vacuum pump may be used; however, a wet type is preferred since it will not be damaged if liquid enters it. If a dry vacuum pump is used, provisions must be made to keep liquid from entering it.

Auxiliary Ejectors

Ejectors function much like exhaust primers. They may be operated by steam, compressed air, water or exhaust gases. To prime a pump using an ejector, open the gas cock in the priming line and operate the ejector until liquid is thrown out the ejector nozzle.

Vacuum Pumps

Air can be exhausted to prime a pump by using a vacuum pump. Either a wet type or a dry type vacuum pump may be used; however, a wet type is preferred since it will not be damaged if liquid enters it. If a dry vacuum pump is used, provisions must be made to keep liquid from entering it.

STARTING

Consult the operations manual furnished with the power source.

Rotation

The correct direction of pump rotation is counter-clockwise when facing the impeller. If the pump is operated in the wrong direction, pump performance could be adversely affected, and the pump could be seriously damaged.



Only operate this pump in the direction indicated by the arrow on the pump body and on the accompanying decal. Otherwise, pump performance could be adversely affected, and the pump could be seriously damaged.

Consult the operating manual furnished with the power source before attempting to start the power source.

If an electric motor is used to drive the pump, remove V-belts, couplings, or otherwise disconnect the pump from the motor before checking motor rotation. Operate the motor independently while observing the direction of the motor shaft, or cooling fan.

If rotation is incorrect on a three-phase motor, have a qualified electrician interchange any two of the three-phase wires to change direction. If rotation is incorrect on a single-phase motor, consult the literature supplied with the motor for specific instructions.

OPERATION

Leakage

No leakage should be visible at pump mating surfaces, or at pump connections or fittings. Keep all line connections and fittings tight to maintain maximum pump efficiency.

Liquid Temperature And Overheating

The **maximum** liquid temperature for this pump is 160° F (71,1°C). Do not apply it at a higher operating temperature.

Overheating can occur if operated with the valves in the suction or discharge lines closed. Operating

against closed valves could bring the liquid to a boil, build pressure, and cause the pump to rupture or explode. If overheating occurs, stop the pump and allow it to cool before servicing it. Refill the pump casing with cool liquid.



Allow an over-heated pump to cool before servicing. Do not remove plates, covers, gauges, or fittings from an over-heated pump. Liquid within the pump can reach boiling temperatures, and vapor pressure within the pump can cause parts being disengaged to be ejected with great force. After the pump cools, drain the liquid from the pump by removing the casing drain plug. Use caution when removing the plug to prevent injury to personnel from hot liquid.

Strainer Check

If a suction strainer has been shipped with the pump or installed by the user, check the strainer regularly, and clean it as necessary. The strainer should also be checked if pump flow rate begins to drop. If a vacuum suction gauge has been installed, monitor and record the readings regularly to detect strainer blockage.

Never introduce air or steam pressure into the pump casing or piping to remove a blockage. This could result in personal injury or damage to the equipment. If backflushing is absolutely necessary, liquid pressure **must** be limited to 50% of the maximum permissible operating pressure shown on the pump performance curve.

Pump Vacuum Check

Since this pump does not have a suction check valve, the discharge line must be fitted with a check valve if a pump vacuum reading is to be taken.

With the pump inoperative, install a vacuum gauge in the system, using pipe dope on the threads. Block the suction line and start the pump. At operating speed the pump should pull a vacuum of 20

inches (508,0 mm) or more of mercury. If it does not, check for air leaks in the seal, gasket, or discharge valve.

Open the suction line, and read the vacuum gauge with the pump primed and at operation speed. Shut off the pump. The vacuum gauge reading will immediately drop proportionate to static suction lift, and should then stabilize. If the vacuum reading falls off rapidly after stabilization, an air leak exists. Before checking for the source of the leak, check the point of installation of the vacuum gauge.

STOPPING

Never halt the flow of liquid suddenly. If the liquid being pumped is stopped abruptly, damaging shock waves can be transmitted to the pump and piping system. Close all connecting valves slowly.

On engine driven pumps, reduce the throttle speed slowly and allow the engine to idle briefly before stopping.



If the application involves a high discharge head, gradually close the discharge throttling valve before stopping the pump.

After stopping the pump, disconnect the power source to ensure that the pump will remain inoperative.

Cold Weather Preservation

In below freezing conditions, drain the pump to prevent damage from freezing. Also, clean out any solids by flushing with a hose. Operate the pump for approximately one minute; this will remove any remaining liquid that could freeze the pump rotating parts. If the pump will be idle for more than a few hours, or if it has been pumping liquids containing a large amount of solids, drain the pump, and flush it thoroughly with clean water. To prevent large solids from clogging the drain port and preventing the pump from completely draining, insert a rod or stiff wire in the drain port, and agitate the liquid during the draining process. Clean out any remaining solids by flushing with a hose.

BEARING TEMPERATURE CHECK

Bearings normally run at higher than ambient temperatures because of heat generated by friction. Temperatures up to 160°F (71,1°C) are considered normal for bearings, and they can operate safely to at least 180°F (82,2°C).

Checking bearing temperatures by hand is inaccurate. Bearing temperatures can be measured accurately by placing a contact-type thermometer against the housing. Record this temperature for future reference.

A sudden increase in bearing temperature is a warning that the bearings are at the point of failing to operate properly. Make certain that the bearing lubricant is of the proper viscosity and at the correct level (see **LUBRICATION** in **MAINTENANCE AND REPAIR**). Bearing overheating can also be caused by shaft misalignment and/or excessive vibration.

When pumps are first started, the bearings may seem to run at temperatures above normal. Continued operation should bring the temperatures down to normal levels.

TROUBLESHOOTING – SECTION D

Review all SAFETY information in Section A.



Before attempting to open or service the pump:

1. Familiarize yourself with this manual.
2. Lock out or disconnect the power source to ensure that the pump will remain inoperative.
3. Allow the pump to completely cool if overheated.
4. Check the temperature before opening any covers, plates, or plugs.
5. Close the suction and discharge valves.
6. Vent the pump slowly and cautiously.
7. Drain the pump.

TROUBLE	POSSIBLE CAUSE	PROBABLE REMEDY
PUMP FAILS TO PRIME	Air leak in suction line. Lining of suction hose collapsed. Leaking or worn seal or pump gasket. Suction check valve or foot valve clogged or binding. Suction lift or discharge head too high. Strainer clogged.	Correct leak. Replace suction hose. Check pump vacuum. Replace leaking or worn seal or gasket. Clean valve. Check piping installation and install bypass line if needed. See INSTALLATION . Check strainer and clean if necessary.
PUMP STOPS OR FAILS TO DELIVER RATED FLOW OR PRESSURE	Air leak in suction line. Lining of suction hose collapsed. Suction intake not submerged at proper level or sump too small.	Correct leak. Replace suction hose. Check installation and correct submergence as needed.

TROUBLE	POSSIBLE CAUSE	PROBABLE REMEDY
<p>PUMP STOPS OR FAILS TO DELIVER RATED FLOW OR PRESSURE (cont.)</p>	<p>Impeller or other wearing parts worn or damaged.</p> <p>Strainer clogged.</p> <p>Impeller clogged.</p> <p>Discharge head too high.</p> <p>Suction lift too high.</p> <p>Leaking or worn seal or pump gasket.</p> <p>Pump speed too slow.</p>	<p>Replace worn or damaged parts. Check that impeller is properly centered and rotates freely.</p> <p>Check strainer and clean if necessary.</p> <p>Free impeller of debris.</p> <p>Install bypass line.</p> <p>Measure lift w/vacuum gauge. Reduce lift and/or friction losses in suction line.</p> <p>Check pump vacuum. Replace leaking or worn seal or gasket.</p> <p>Check engine output; consult engine operation manual.</p>
<p>PUMP REQUIRES TOO MUCH POWER</p>	<p>Pump speed too high.</p> <p>Discharge head too low.</p> <p>Liquid solution too thick.</p>	<p>Check driver output; check that sheaves or couplings are correctly sized.</p> <p>Adjust discharge valve.</p> <p>Dilute if possible.</p>
<p>PUMP CLOGS FREQUENTLY</p>	<p>Discharge flow too slow.</p> <p>Suction check valve or foot valve clogged or binding.</p>	<p>Open discharge valve fully to increase flow rate, and run engine at maximum governed speed.</p> <p>Clean valve.</p>
<p>EXCESSIVE NOISE</p>	<p>Cavitation in pump.</p> <p>Pumping entrained air.</p> <p>Pump or drive not securely mounted.</p> <p>Impeller clogged or damaged.</p>	<p>Reduce suction lift and/or friction losses in suction line. Record vacuum and pressure gauge readings and consult local representative or factory.</p> <p>Locate and eliminate source of air bubble.</p> <p>Secure mounting hardware.</p> <p>Clean out debris; replace damaged parts.</p>
<p>BEARINGS RUN TOO HOT</p>	<p>Bearing temperature is high, but within limits.</p> <p>Low or incorrect lubricant.</p> <p>Suction and discharge lines not properly supported.</p> <p>Drive misaligned.</p>	<p>Check bearing temperature regularly to monitor any increase.</p> <p>Check for proper type and level of lubricant.</p> <p>Check piping installation for proper support.</p> <p>Align drive properly.</p>

PREVENTIVE MAINTENANCE

Since pump applications are seldom identical, and pump wear is directly affected by such things as the abrasive qualities, pressure and temperature of the liquid being pumped, this section is intended only to provide general recommendations and practices for preventive maintenance. Regardless of the application however, following a routine preventive maintenance schedule will help assure trouble-free performance and long life from your Gorman-Rupp pump. For specific questions concerning your application, contact your Gorman-Rupp distributor or the Gorman-Rupp Company.

Record keeping is an essential component of a good preventive maintenance program. Changes in suction and discharge gauge readings (if so

equipped) between regularly scheduled inspections can indicate problems that can be corrected before system damage or catastrophic failure occurs. The appearance of wearing parts should also be documented at each inspection for comparison as well. Also, if records indicate that a certain part (such as the seal) fails at approximately the same duty cycle, the part can be checked and replaced before failure occurs, reducing unscheduled down time.

For new applications, a first inspection of wearing parts at 250 hours will give insight into the wear rate for your particular application. Subsequent inspections should be performed at the intervals shown on the chart below. Critical applications should be inspected more frequently.

Preventive Maintenance Schedule					
Item	Service Interval*				
	Daily	Weekly	Monthly	Semi-Annually	Annually
General Condition (Temperature, Unusual Noises or Vibrations, Cracks, Leaks, Loose Hardware, Etc.)	I				
Pump Performance (Gauges, Speed, Flow)	I				
Bearing Lubrication		I			R
Seal Lubrication (And Packing Adjustment, If So Equipped)		I			R
V-Belts (If So Equipped)			I		
Air Release Valve Plunger Rod (If So Equipped)			I	C	
Front Impeller Clearance (Wear Plate)				I	
Rear Impeller Clearance (Seal Plate)				I	
Check Valve					I
Pressure Relief Valve (If So Equipped)					C
Pump and Driver Alignment					I
Shaft Deflection					I
Bearings					I
Bearing Housing					I
Piping					I
Driver Lubrication – See Mfgr’s Literature					I
Legend: I = Inspect, Clean, Adjust, Repair or Replace as Necessary C = Clean R = Replace * Service interval based on an intermittent duty cycle equal to approximately 4000 hours annually. Adjust schedule as required for lower or higher duty cycles or extreme operating conditions.					

PUMP MAINTENANCE AND REPAIR - SECTION E

MAINTENANCE AND REPAIR OF THE WEARING PARTS OF THE PUMP WILL MAINTAIN PEAK OPERATING PERFORMANCE.

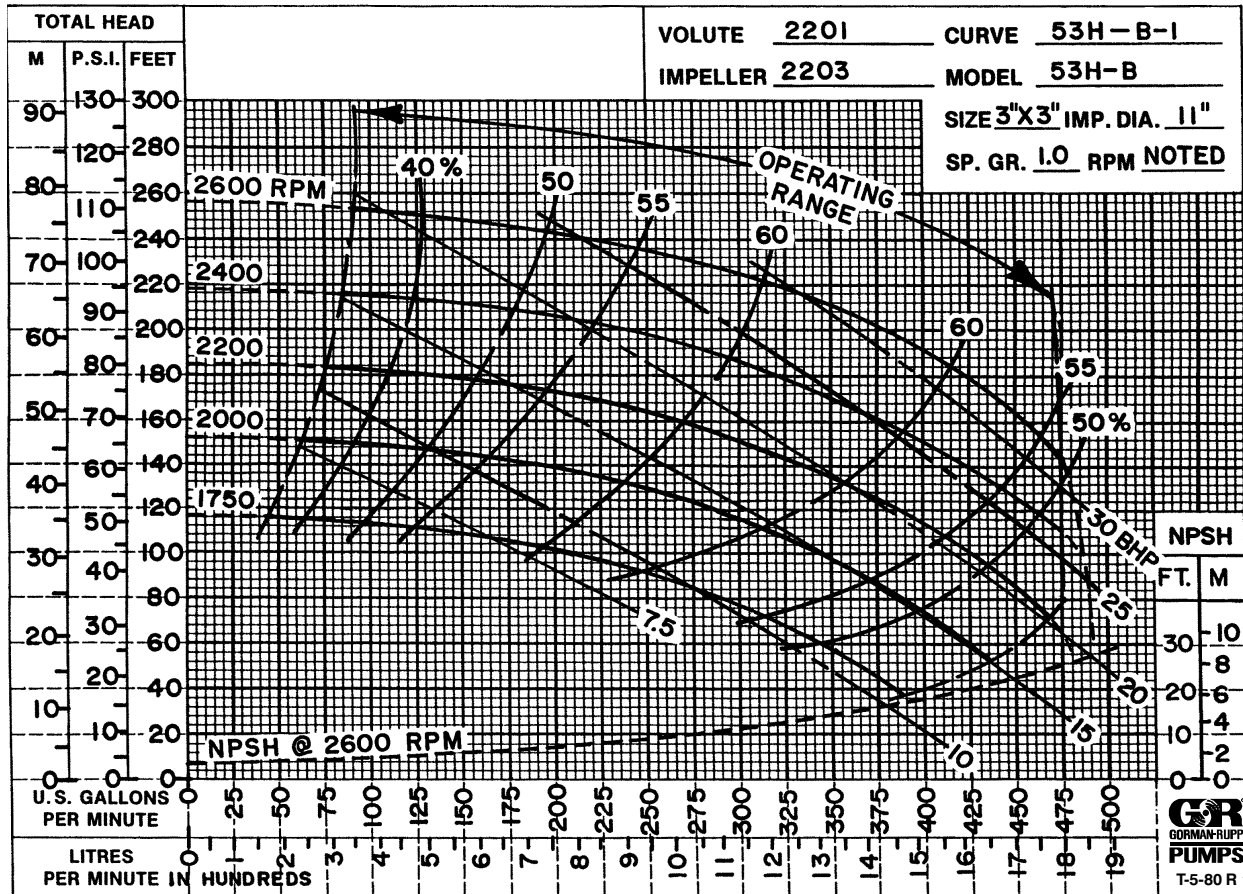

* STANDARD PERFORMANCE FOR PUMP MODEL 53H2-B

* Based on 70° F (21° C) clear water at sea level with minimum suction lift. Since pump installations are seldom identical, your performance may be different due to such factors as viscosity, specific gravity, elevation, temperature, and impeller trim.



CAUTION

Pump speed and operating condition points must be within the continuous performance range shown on the curve.

SECTION DRAWING

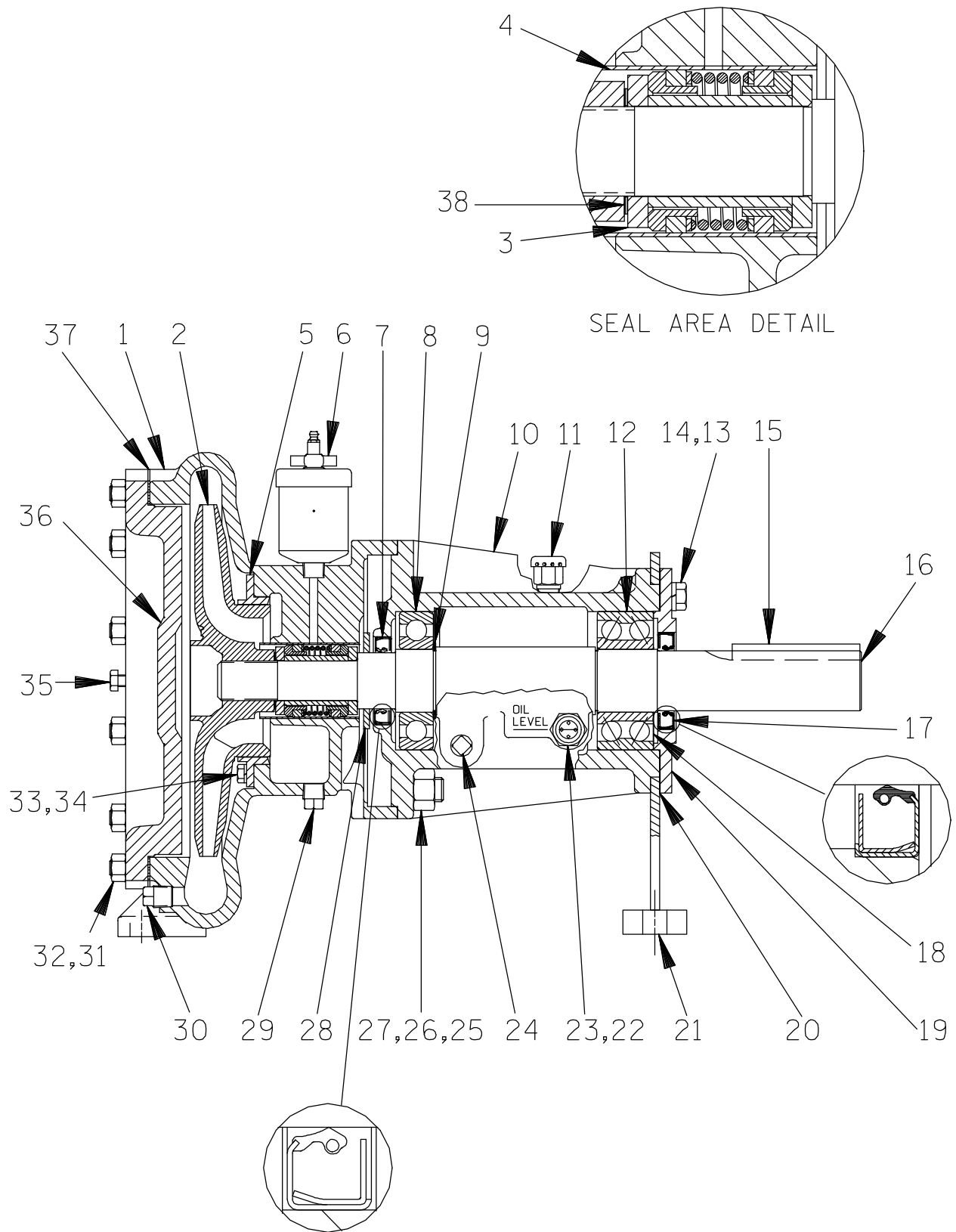

Figure 1. Pump Model 53H2-B

PARTS LIST
Pump Model 53H2-B
 (From S/N 806819 Up)

ITEM NO.	PART NAME	PART NUMBER	MAT'L CODE	QTY	ITEM NO.	PART NAME	PART NUMBER	MAT'L CODE	QTY
1	PUMP CASING	2201	10010	1	27	HEX NUT	D08	15991	4
2 *	IMPELLER	2203	10010	1	28	SLINGER RING	3209	19120	1
3 *	GREASE SEAL ASSY	GS1250	----	1	29	PIPE PLUG	P06	15079	1
4 *	SEAL LINER	2205	14080	1	30	CASING DRAIN PLUG	P06	15079	1
5 *	WEAR RING	2204	14000	1	31	STUD	C08007	15991	12
6	GREASE CUP	S1509	----	1	32	HEX NUT	D08	15991	12
7 *	OIL SEAL	S181	----	1	33	HEX HD CAPSCREW	B0503	14990	2
8 *	BALL BEARING	S1077	----	1	34	LOCK WASHER	J05	15991	2
9	RETAINING RING	S1164	----	2	35	HEX HD CAPSCREW	B0604	15991	2
10	PEDESTAL	5557B	10010	1	36	COVER PLATE	2202C	10010	1
11	AIR VENT	S1703	----	1	37 *	CASING GASKET	2202G	18000	1
12 *	BALL BEARING	23421-461	----	1	38	IMP ADJ SHIM SET	37J	17090	REF
13	HEX HD CAPSCREW	B0805	15991	4	NOT SHOWN:				
14	LOCK WASHER	J08	15991	4		NAME PLATE	2613D	13990	1
15 *	SHAFT KEY	N0816	15990	1		DRIVE SCREW	BM#04-03	17000	4
16 *	IMPELLER SHAFT	5560	15010	1		SUCTION STICKER	6588AG	----	1
17 *	OIL SEAL	S1917	----	1		DISCHARGE STICKER	6588BJ	----	1
18	BEARING ADJ SHIM SET	8546	15990	1		G-R DECAL	GR-03	----	1
19	BEARING CAP	5558A	10010	1		ROTATION DECAL	2613M	----	1
20 *	BEARING CAP GASKET	5558G	18000	1		LUBE DECAL	38816-079	----	1
21	PEDESTAL FOOT	5559	24000	1		INSTRUCTION TAG	38817-011	----	1
22	PIPE PLUG	P06	15079	1		GREASE CUP INSTR	6588BD	----	1
23	SIGHT GAUGE	26714-011	----	1		INSTRUCTION TAG	38817-026	----	1
24	PEDESTAL DRAIN PLUG	P06	15079	1		PIPE PLUG	P08	15079	1
25	HEX HD CAPSCREW	B0811	15991	4		PIPE PLUG	P06	15079	1
26	LOCK WASHER	J08	15991	4	OPTIONAL:				
						HAND PRIMER ASSY	GRP43-02	----	1

* INDICATES PARTS RECOMMENDED FOR STOCK

PUMP AND SEAL DISASSEMBLY AND REASSEMBLY

Review all SAFETY information in Section A.

Follow the instructions on all tags, label and decals attached to the pump.

This pump requires little service due to its rugged, minimum-maintenance design. However, if it becomes necessary to inspect or replace the wearing parts, follow these instructions which are keyed to the sectional view (see Figure 1) and the accompanying parts list.

This manual will alert personnel to known procedures which require special attention, to those which could damage equipment, and to those which could be dangerous to personnel. However, this manual cannot possibly anticipate and provide detailed precautions for every situation that might occur during maintenance of the unit. Therefore, it is the responsibility of the owner/maintenance personnel to ensure that **only** safe, established maintenance procedures are used, and that any procedures not addressed in this manual are performed **only** after establishing that neither personal safety nor pump integrity are compromised by such practices.

Before attempting to service the pump, lock out or disconnect the power source to ensure that it will remain inoperative. Close all valves in the suction and discharge lines.

For power source disassembly and repair, consult the literature supplied with the power source, or contact your local power source representative.



Before attempting to open or service the pump:

1. **Familiarize yourself with this manual.**
2. **Disconnect or lock out the power source to ensure that the pump will remain inoperative.**
3. **Allow the pump to completely cool if overheated.**

4. **Check the temperature before opening any covers, plates, or plugs.**
5. **Close the suction and discharge valves.**
6. **Vent the pump slowly and cautiously.**
7. **Drain the pump.**



Use lifting and moving equipment in good repair and with adequate capacity to prevent injuries to personnel or damage to equipment.

Cover Plate Removal

The impeller, wear ring and seal assembly can be serviced by removing the cover plate (36).

Remove the casing drain plugs (29 and 30) and drain the pump. Clean and reinstall the drain plugs.

Remove the nuts (32) and use the jacking screws (35) to break the cover plate loose from the pump casing (1). Remove the cover plate and gasket (37).

Impeller Removal

Before removing the impeller, screw the cross arm on the automatic lubricating grease cup (6) clockwise until it rests against the cover (see Figure 6) to prevent the grease in the cup from escaping. Remove the grease cup from the pump casing (1).

Immobilize the impeller by inserting a metal rod between the impeller vanes, being careful not to damage the vanes.

With the impeller rotation blocked, see Figure 2 and use a long piece of heavy bar stock to pry against the arm of the lathe dog in a counterclockwise direction (when facing the drive end of the shaft). **Use caution** not to damage the shaft or keyway. When the impeller breaks loose, remove the lathe dog, key and wood block.

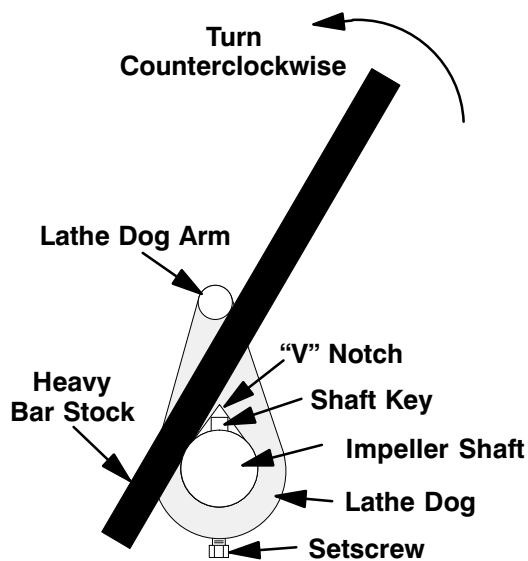

Figure 2. Loosening Impeller

Remove the metal rod blocking impeller rotation and unscrew the impeller from the shaft. Use caution when removing the impeller; tension on the seal spring will be released as the impeller is removed.

Remove the impeller adjusting shims (38). Tie and tag the shims or measure and record their thickness for ease of reassembly.

Pump Casing, Wear Ring and Seal Removal

(Figures 1 and 4)

Inspect the wear ring (5) for excessive wear or scoring. If replacement is required, remove the hardware (33 and 34) securing the wear plate to the pump casing. Install two 5/16-18 UNC-2B by 1-inch long capscrews in the two tapped holes in the wear ring. Tighten the screws in an alternating pattern to "jack" the wear ring out of the pump casing.

The pump casing and seal assembly (3) must be removed as a unit. Remove the hardware (25, 26 and 27) slide the pump casing and seal assembly off the shaft as a single unit. Lay the pump casing on a flat surface with the impeller side up and press the seal components from the pump casing.

If no further disassembly is required, refer to **Seal Reassembly**.

Shaft and Bearing Removal and Disassembly

When the pump is properly operated and maintained, the shaft and bearings should not require disassembly. Disassemble the shaft and bearings **only** when there is evidence of wear or damage.



Shaft and bearing disassembly in the field is not recommended. These operations should be performed only in a properly equipped shop by qualified personnel.

Remove any pedestal mounting hardware. Remove the shaft key (15).

Remove the pedestal drain plug (24) and drain the lubricant from the pedestal. Clean and reinstall the drain plug.

Remove the hardware (13 and 14) securing the bearing cap (19) and remove the cap and gasket (20). Press the oil seal (17) from the bearing cap.

Slide the pedestal foot (21) off the pedestal. Remove the bearing shim set (18). Tie and tag the shims, or measure and record their thickness for ease of reassembly.

Remove the slinger ring (28). Place a block of wood against the impeller end of the shaft and tap the shaft and assembled bearings (8 and 12) from the pedestal bore. **Be careful** not to damage the shaft threads.

Press the oil seal (7) from the pedestal bore.

After removing the shaft and bearings, clean and inspect the bearings **in place** as follows.



To prevent damage during removal from the shaft, it is recommended that bearings be cleaned and inspected **in place**. It is **strongly** recommended that the bearings be replaced **any** time the shaft and bearings are removed.

Clean the pedestal, shaft and all component parts (except the bearings) with a soft cloth soaked in

cleaning solvent. Inspect the parts for wear or damage and replace as necessary.



Most cleaning solvents are toxic and flammable. Use them only in a well ventilated area free from excessive heat, sparks, and flame. Read and follow all precautions printed on solvent containers.

Clean the bearings thoroughly in **fresh** cleaning solvent. Dry the bearings with filtered compressed air and coat with light oil.

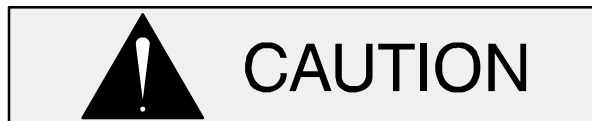

Bearings must be kept free of all dirt and foreign material. Failure to do so will greatly shorten bearing life. **Do not** spin dry bearings. This may scratch the balls or races and cause premature bearing failure.

Rotate the bearings by hand to check for roughness or binding and inspect the bearing balls. If rotation is rough or the bearing balls are discolored, replace the bearings.

The bearing tolerances provide a tight press fit onto the shaft and a snug slip fit into the pedestal. Replace the bearings, shaft, or pedestal if the proper bearing fit is not achieved.

If bearing replacement is required, use a bearing puller or an arbor (or hydraulic) press to remove the bearings from the impeller shaft.

It is not necessary to remove the retaining rings (9) from the shaft unless replacement is required. Use snap ring pliers to remove the snap rings from the shaft.

Shaft and Bearing Reassembly And Installation

Clean and inspect the bearings as indicated in **Shaft and Bearing Removal and Disassembly**.



To prevent damage during removal from the shaft, it is recommended that bearings be cleaned and inspected **in place**. It is **strongly** recommended that the bearings be replaced **any** time the shaft and bearings are removed.

Clean the pedestal, shaft and all component parts (except the bearings) with a soft cloth soaked in cleaning solvent. Inspect the parts for wear or damage as necessary.



Most cleaning solvents are toxic and flammable. Use them only in a well ventilated area free from excessive heat, sparks, and flame. Read and follow all precautions printed on solvent containers.

Inspect the shaft for distortion, nicks or scratches, or for thread damage on the impeller end. Dress small nicks and burrs with a fine file or emery cloth. Replace the shaft if defective.

If removed, install the retaining rings (9) in the grooves in the impeller shaft (16).

The bearings may be heated to ease installation. An induction heater, hot oil bath, electric oven, or hot plate may be used to heat the bearings. Bearings should **never** be heated with a direct flame or directly on a hot plate.

NOTE

*If a hot oil bath is used to heat the bearings, both the oil and the container must be **absolutely** clean. If the oil has been previously used, it must be **thoroughly** filtered.*

Heat the bearings to a uniform temperature **no higher than 250°F (120°C)**, and slide the bearings onto the shaft, one at a time, until they are fully seated. This should be done quickly, in one continuous motion, to prevent the bearings from cooling and sticking on the shaft.



WARNING!

Use caution when handling hot bearings to prevent burns.

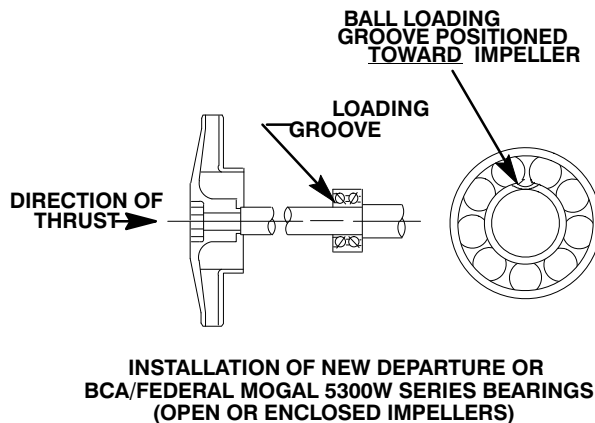

NOTE
Position the outboard bearing (12) on the shaft as indicated by the following illustration.

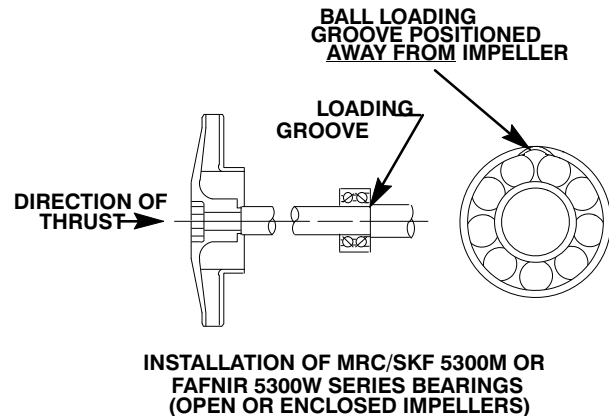

Figure 3. Bearing Installation

After the bearings have been installed and allowed to cool, check to ensure that they have not moved away from the retaining rings in shrinking. If movement has occurred, use a suitably sized sleeve and a press to reposition the bearings against the retaining rings.

If heating the bearings is not practical, use a suitably sized sleeve and an arbor (or hydraulic) press to install the bearings on the shaft.



CAUTION

When installing the bearings onto the shaft, **never** press or hit against the outer race, balls, or ball cage. Press **only** on the inner race.

Slide the shaft and assembled bearings into the pedestal bore until the inboard bearing is fully seated against the pedestal shoulder.



CAUTION

When installing the shaft and bearings into the bearing bore, push against the outer race. **Never** hit the balls or ball cage.

Position the inboard oil seal (7) over the impeller shaft with the lip positioned as shown in Figure 1. Use a suitably sized dowel to press the oil seal into the pedestal bore until the face is **just flush** with the machined surface on the pedestal. Use caution not to roll the lip of the oil seal during installation.

Install the same thickness of bearing shims (18) as previously removed.

Replace the bearing cap gasket (20). Install the pedestal foot (21) and secure the bearing cap using the hardware (13 and 14). Check shaft endplay.

NOTE

Impeller shaft endplay should be between .002 and .010 inch (0,05 mm to 0,25 mm). Add or remove bearing shims to establish the correct endplay.

Lubricate the shaft in the area of the oil seal (17) and position the oil seal over the impeller shaft with the lip positioned as shown in Figure 1. Use a suitably sized dowel to press the oil seal into the bearing cap until the face is **just flush** with the outer face of the bearing cap. Use caution not to roll or cut the lip of the oil seal on the shaft keyway.

Lubricate the bearing cavity as indicated in **LUBRICATION** at the end of this section.

Pump Casing, Wear Ring and Seal Installation

(Figures 1 and 4)

Clean the seal cavity and shaft with a cloth soaked in fresh cleaning solvent.



Most cleaning solvents are toxic and flammable. Use them only in a well ventilated area free from excessive heat, sparks, and flame. Read and follow all precautions printed on solvent containers.

Inspect the impeller shaft for damage. Small scratches or nicks may be removed with a fine file or emery cloth. If excessive wear exists, the shaft will have to be replaced.

The seal is not normally reused because wear patterns on the finished faces cannot be realigned during reassembly. This could result in premature failure. If necessary to reuse an old seal in an emer-

gency, **carefully** wash all metallic parts in **fresh** cleaning solvent and allow to dry thoroughly.

Handle the seal parts with extreme care to prevent damage. Be careful not to contaminate precision finished faces; even fingerprints on the faces can shorten seal life. If necessary, clean the faces with a non-oil based solvent and a clean, lint-free tissue. Wipe **lightly** in a concentric pattern to avoid scratching the faces.

Inspect the seal components for wear, scoring, grooves, and other damage that might cause leakage. Clean and polish the seal spacer sleeve, or replace it if there are nicks or cuts on either end. If any components are worn, replace the complete seal; **never mix old and new seal parts.**

If a replacement seal is being used, remove it from the container and inspect the precision finished faces to ensure that they are free of any foreign matter.

To ease installation of the seal, lubricate the packing rings and spacer sleeve with water or a very **small** amount of oil, and apply a drop of light lubricating oil on the finished faces. Assemble the seal as follows, (see Figure 4).

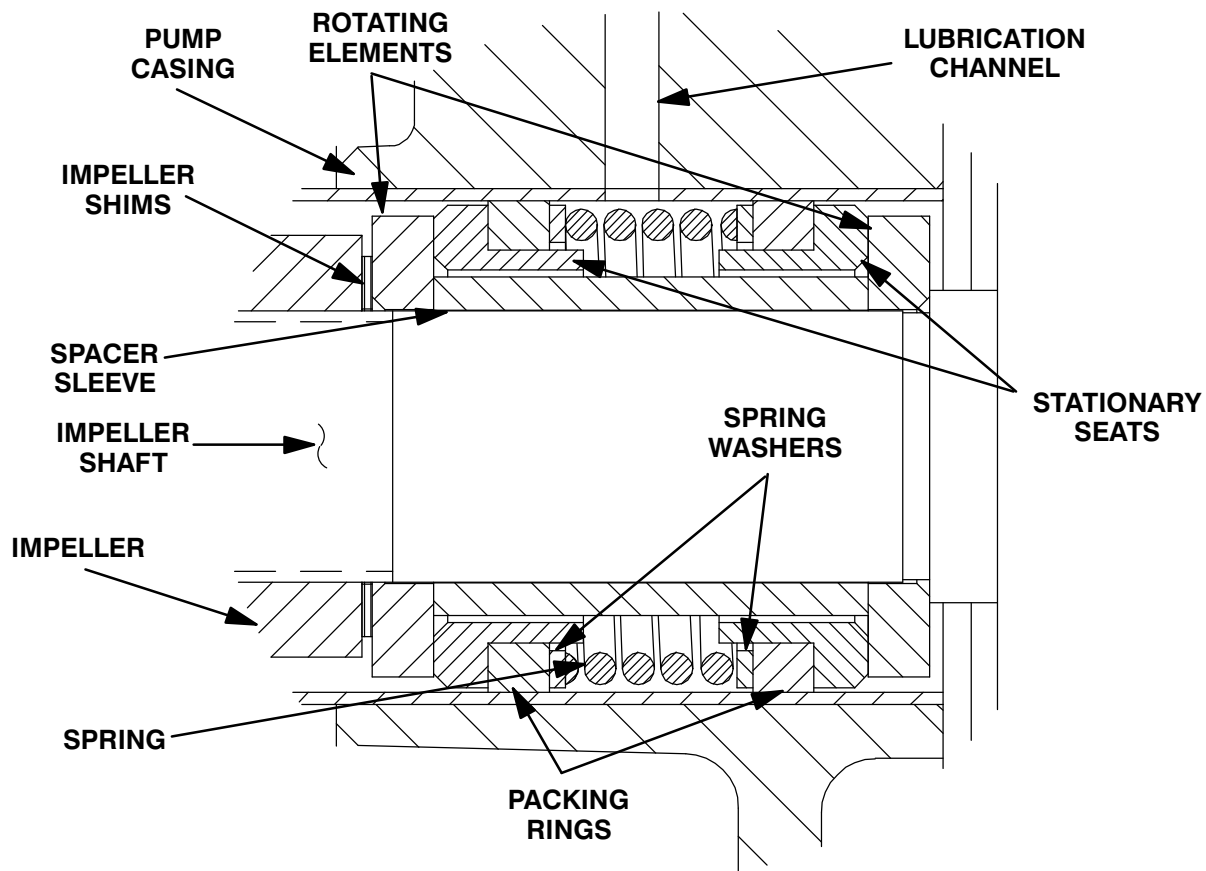

Figure 4. GS1250 Seal Assembly



This seal is not designed for operation at temperatures above 160°F (71°C). Do not use at higher operating temperatures.

Before installing the seal, inspect the bore of the seal liner (4) for wear or grooves which might cause leakage or damage to the seal packing rings. If the seal liner requires replacement, position the pump casing on the bed of an arbor (or hydraulic) press with the impeller end facing down and use a new sleeve to force the old one out. Press the new sleeve into the pump casing until the end of the sleeve is just flush with the bore shoulder in the pump casing.

After the new liner is properly installed, a 1/4-inch (6,4 mm) diameter hole must be drilled through it to permit the flow of lubricant to the seal assembly. **Be careful** to center the drill in the threaded grease piping hole and to not damage the threads. Deburr

the hole from the inside of the seal liner after drilling.

Position the assembled pump casing and seal liner over the impeller shaft with the hole for the grease cup (6) facing up. Secure the pump casing to the pedestal with the previously removed hardware (25, 26 and 27).

Before installing the seal, lubricate the seal liner with water or a very **small** amount of oil, and apply a drop of light lubricating oil on the finished faces.

Position the inboard rotating element on the shaft with the chamfer facing the shaft shoulder. Slide the element onto the shaft until fully seated against the shaft shoulder.

Subassemble the inboard stationary seat, packing ring and spring washer, and press the subassembly into the lubricated seal liner. A push tube cut from a length of plastic pipe would aid this installation. The O.D. of the tube should be slightly smaller than the I.D. of the seal liner.

Install the spacer sleeve and spring.

Subassemble the outboard stationary seat, packing ring and spring washer. Press this subassembly into the seal liner.

Install the outboard rotating element with the chamfered side facing the impeller end of the shaft.

Install the automatic grease cup in the hole in the pump casing. After the impeller is installed, lubricate the seal assembly as indicated in **LUBRICATION**.

If the wear ring (5) was removed during disassembly, position a new wear ring against the pump casing so the mounting holes in the wear ring align with the holes in the pump casing. Install the capscrews and lockwashers (33 and 34) and use the capscrews to press the wear ring into the pump casing until fully seated.

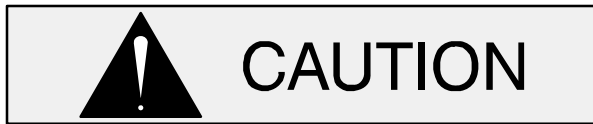

The wear ring **must** seat squarely in the

casing bore or binding and/or excessive wear will result.

Impeller Installation

Inspect the impeller, and replace it if cracked or badly worn. Install the same thickness of impeller shims (38) as previously removed and screw the impeller onto the shaft until fully seated.

For maximum pump efficiency, the impeller should be centered within the volute scroll.

To verify the impeller positioning, measure the pump casing and impeller as shown in Figure 5. Use these measurements to calculate the required impeller location (dimension E). Add or remove impeller adjusting shims until dimension E is obtained.

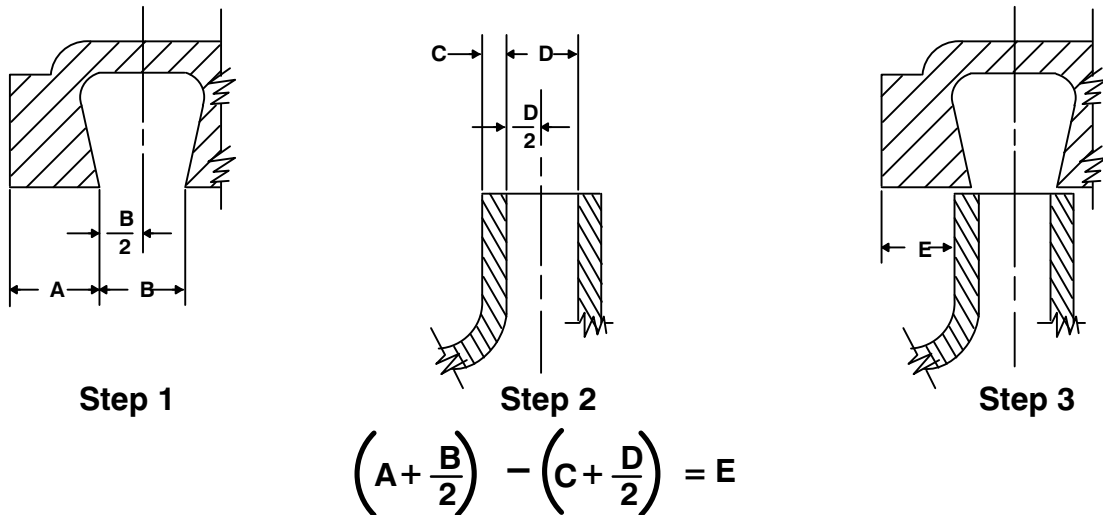

Figure 5. Centering Impeller Within Volute Scroll

NOTE

After the impeller has been properly positioned, check for free rotation. Correct any scraping or binding before further reassembly.

studs (31) and secure it to the pump casing with the nuts (32).

Cover Plate Installation

Install a new casing gasket over the studs (31). Make sure the jacking screws (35) are fully retracted and position the cover plate (36) over the

Final Pump Assembly

Be sure the pump assembly is securely mounted to the power source and base.

Install the suction and discharge lines and open all valves. Make certain that all piping connections are tight, properly supported and secure.

Be sure the pump and power source have been properly lubricated, see **LUBRICATION**.

Refer to **OPERATION**, Section C, before putting the pump back into service.

LUBRICATION

Bearings

The bearing housing was fully lubricated when shipped from the factory. Check the oil level regularly through the sight gauge (23) and maintain it at the middle of the gauge. When lubrication is required, add SAE No. 30 non-detergent oil through the hole for the air vent (11). **Do not** over-lubricate. Over-lubrication can cause the bearings to over-heat, resulting in premature bearing failure.

NOTE

The white reflector in the sight gauge must be positioned horizontally to provide proper drainage.

Under normal conditions, drain the pedestal once each year and refill with clean oil. Change the oil

more frequently if the pump is operated continuously or installed in an environment with rapid temperature change.



Monitor the condition of the bearing lubricant regularly for evidence of rust or moisture condensation. This is especially important in areas where variable hot and cold temperatures are common.

For cold weather operation, consult the factory or a lubricant supplier for the recommended grade of oil.

Seal Assembly

Fill the grease cup (6) through the grease fitting with No. 2 lithium base grease until grease escapes from the relief hole. Turn the grease cup arm counterclockwise until it is at the top of the stem; this will release the spring to apply grease to the seal (see Figure 6).

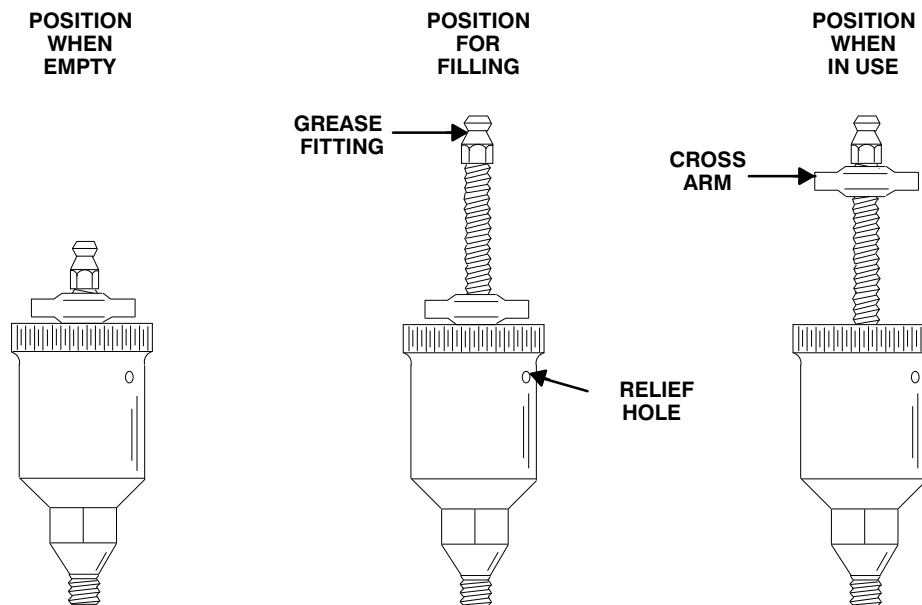

Figure 6. Automatic Lubricating Grease Cup

NOTE

Some smoking and leakage may occur after installing a new seal assembly. This should stop after the pump has run a while and the lapped seal faces have seated in.

Power Source

Consult the literature supplied with the power source, or contact your local power source representative.

**For U.S. and International Warranty Information,
Please Visit www.grpumps.com/warranty**

or call:

U.S.: 419-755-1280

International: +1-419-755-1352

**For Canadian Warranty Information,
Please Visit www.grcanada.com/warranty**

or call:

519-631-2870