



**INSTALLATION, OPERATION, PARTS LIST,  
AND MAINTENANCE MANUAL**



**THE GORMAN-RUPP COMPANY • MANSFIELD, OHIO**

GORMAN-RUPP OF CANADA LIMITED • ST. THOMAS, ONTARIO, CANADA

Printed in U.S.A.

Copyright by the Gorman-Rupp Company



## TABLE OF CONTENTS

INTRODUCTION . . . . .	I-1
WARNINGS - SECTION A . . . . .	A-1
INSTALLATION - SECTION B . . . . .	B-1
PREINSTALLATION INSPECTION . . . . .	B-1
PUMP INSTALLATION . . . . .	B-2
Pump Specifications . . . . .	B-2
Pump And Mounting Dimensions . . . . .	B-2
VEHICLE REQUIREMENTS . . . . .	B-3
Tank Preparation . . . . .	B-4
Vehicle Configuration . . . . .	B-4
Brake Installation . . . . .	B-4
Air Cylinder Pressure . . . . .	B-4
POSITIONING PUMP . . . . .	B-5
Lifting . . . . .	B-5
Mounting Location . . . . .	B-5
MOUNTING BRACKETS . . . . .	B-5
DRIVE FLANGE INSTALLATION . . . . .	B-7
New Installation . . . . .	B-7
Retro-fit Installation . . . . .	B-8
DRIVE SHAFT AND LINKAGE CONNECTIONS . . . . .	B-9
Drive Shaft Alignment . . . . .	B-9
Speedometer Connection . . . . .	B-10
Gear Shift Connections . . . . .	B-11
SUCTION AND DISCHARGE PIPING . . . . .	B-12
Typical System Installation . . . . .	B-12
Piping . . . . .	B-13
VALVES . . . . .	B-14
Eductors . . . . .	B-16
OPERATION - SECTION C . . . . .	C-1
PRIMING . . . . .	C-1
GROUNDING . . . . .	C-2
STARTING . . . . .	C-2
Rotation . . . . .	C-2
Drive . . . . .	C-3
OPERATION . . . . .	C-3
Operating Controls . . . . .	C-3
Shifting Sequence . . . . .	C-3
Liquid Temperature And Overheating . . . . .	C-4
STOPPING . . . . .	C-4
OPERATING CHECKS . . . . .	C-5
Leakage . . . . .	C-5
Strainer Check . . . . .	C-5
GEARBOX TEMPERATURE CHECK . . . . .	C-5
TROUBLESHOOTING - SECTION D . . . . .	D-1
MAINTENANCE AND REPAIR - SECTION E . . . . .	E-1
PERFORMANCE CURVE . . . . .	E-1
PUMP MODEL - PARTS LIST . . . . .	E-3
REAR CROSS MEMBER ASSY - PARTS LIST . . . . .	E-5
GEARBOX ASSY - PARTS LIST . . . . .	E-7
GEARBOX ASSY - PARTS LIST . . . . .	E-9
PUMP, SEAL, AND GEARBOX DISASSEMBLY AND REASSEMBLY . . . . .	E-10
Maintenance And Repair . . . . .	E-10
Pump End Only Disassembly . . . . .	E-11
Pump End Only Reassembly . . . . .	E-12
GEARBOX DISASSEMBLY . . . . .	E-15
Removing Pump Unit . . . . .	E-15

Air Shift Cover Disassembly . . . . .	E-16
Drive Flange Removal . . . . .	E-16
Output Shaft Disassembly . . . . .	E-16
Input Shaft Disassembly . . . . .	E-17
Idler Shaft Disassembly . . . . .	E-17
Impeller Shaft Disassembly . . . . .	E-17
Gearbox Reassembly . . . . .	E-17
Idler Shaft Reassembly . . . . .	E-18
Impeller Shaft Reassembly . . . . .	E-19
Input Shaft Reassembly . . . . .	E-19
Output Shaft Reassembly . . . . .	E-20
Drive Flange Reassembly . . . . .	E-21
Air Shift Cover Reassembly . . . . .	E-21
Reinstalling Pump Unit . . . . .	E-22
LUBRICATION . . . . .	E-22
Pump Shaft Seal . . . . .	E-22
Trunnion Bracket . . . . .	E-23
Gearbox Assembly . . . . .	E-23

INTRODUCTION

This Installation, Operation, and Maintenance Manual is designed to help you achieve the best performance and longest life from your Gorman-Rupp pump.

This pump is an O Series, enclosed impeller, self-priming centrifugal model with straight-in suction without a suction check valve. The pump is designed for vehicular mounting in petroleum service, and has an integral split-shaft gearbox engineered for midship installation.

If there are any questions regarding the pump or its application which are not covered in this manual or in other literature accompanying this unit, please contact your Gorman-Rupp distributor, or write:

The Gorman-Rupp Company	or	Gorman-Rupp of Canada Limited
P.O. Box 1217		70 Burwell Road
Mansfield, Ohio 44901		St. Thomas, Ontario N5P 3R7

For information or technical assistance on the truck chassis, contact the truck chassis manufacturer's local dealer or representative.

The following are used to alert maintenance personnel to procedures which require special attention, to those which could damage equipment, and to those which could be dangerous to personnel:

NOTE

Instructions to aid in installation, operation, and maintenance or which clarify a procedure.

CAUTION

Instructions which must be followed to avoid causing damage to the product or other equipment incidental to the installation. These instructions describe the requirements and the possible damage which could result from failure to follow the procedures.

WARNING

```

////////////////////////////////////
//
// These instructions must be followed to avoid causing in- //
// jury or death to personnel, and describe the procedure //
// required and the injury which could result from failure //
// to follow the procedure. //
// //
////////////////////////////////////

```



WARNINGS - SECTION A

THESE WARNINGS APPLY TO 0 SERIES SPLIT-SHAFT REFUELER PUMPS. GORMAN-RUPP HAS NO CONTROL OVER OR PARTICULAR KNOWLEDGE OF THE TRUCK CHASSIS WHICH WILL BE USED. REFER TO THE MANUAL ACCOMPANYING THE TRUCK CHASSIS BEFORE ATTEMPTING TO BEGIN OPERATION.

WARNING

Before attempting to open or service the pump:
1. Familiarize yourself with this manual.
2. Turn off the vehicle ignition to ensure that the pump will remain inoperative.
3. Allow the pump to cool if overheated.
4. Vent the pump slowly and cautiously.
5. Close the suction and discharge valves.
6. Check the temperature before opening any covers, plates, or plugs.
7. Drain the pump.

WARNING

Before operating or servicing the pump, be certain proper safety practices are followed. Provide adequate ventilation, prohibit smoking, wear static-resistant clothing and shoes. Clean up all fuel spills immediately after occurrence.

WARNING

Do not operate the pump against a closed discharge valve for long periods of time. This could bring the liquid to a boil, build pressure, and cause the pump to rupture or explode.

WARNING

Overheating may produce dangerous fumes. Use extreme caution when venting the pump, or when removing covers, plates, plugs, or fittings.

WARNINGS

WARNING

```

////////////////////////////////////
//
// After the vehicle is positioned for pump maintenance, //
// block the wheels and set the emergency brake before at- //
// tempting to disconnect the drive shaft or remove the //
// pump. Be sure the pump is properly reinstalled and se- //
// cure before operation. //
// //
////////////////////////////////////

```

WARNING

```

////////////////////////////////////
//
// Never tamper with the governor to gain more power. The //
// governor establishes safe operating limits that should //
// not be exceeded. Limit input speed and operating range //
// as indicated on the performance curve. //
// //
////////////////////////////////////

```

WARNING

```

////////////////////////////////////
//
// Decals and tags vital to pump operation were shipped //
// loose with the pump. Affix these decals in a prominent //
// place visible to the pump operator. //
// //
////////////////////////////////////

```

CAUTION

Never run the pump dry of pumping medium. There must be a supply of liquid to the pump at all times to prevent destruction of the shaft seal faces.

CAUTION

This pump has been shipped dry of gearbox lubrication. The gearbox must be lubricated before the pump is operated (see LUBRICATION in Section E.).



INSTALLATION

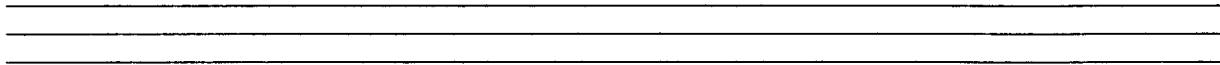

INSTALLATION - SECTION B

Since pump installations are seldom identical, this section offers only general recommendations and practices required to inspect, position, and arrange the pump and piping.

WARNING

Warning text enclosed in a box with slashes: // DO NOT test or operate this pump and integral gearbox before reading the installation and operation instructions in this manual.

Model 06C15-GH1 is a self-priming centrifugal pump with an integral gearbox assembly. The entire unit is designed for midship mounting between the frame members of a petroleum handling vehicle. The gearbox replaces a part of the main drive shaft connecting the transmission to the rear axle.

This design permits full utilization of engine power to selectively operate the pump or the rear driving wheels on the vehicle. Both can not be operated at the same time.

PREINSTALLATION INSPECTION

The pump assembly was inspected and tested before shipment from the factory. Before installation, inspect the pump for damage which may have occurred during shipment. Check as follows:

- a. Inspect the pump assembly for cracks, dents, damaged threads, and other obvious damage.
b. Check for and tighten loose bolts, nuts, capscrews, and other attaching hardware. Since gaskets tend to shrink after drying, check for and tighten loose nuts and capscrews securing mating surfaces.
c. Carefully read all tags, decals, and markings on the pump assembly, and perform all duties indicated. Note the direction of rotation indicated on the pump. Check that the pump shaft rotates in the required direction.

CAUTION

Only operate the pump input shaft in a clockwise direction while facing the shaft. Otherwise, the impeller could become loosened from the shaft and seriously damage the pump.

- d. The gearbox assembly was shipped dry of lubricant. Refer to LUBRICATION in the MAINTENANCE AND REPAIR section of this manual and perform duties as instructed.

**PUMP INSTALLATION**

**Pump Specifications**

See Table 1 and 1A for the typical pump specifications and gearbox data.

**Table 1. Pump Specifications**

Pump Type	Self-priming, centrifugal with enclosed impeller
Suction	6-inch "victaulic" fitting
Discharge	4-inch petroleum flange
Nominal Capacity	See Performance Curve - Page E-1
Impeller Shaft Seal	Mechanical self-lubricated
Gearbox (Air Shift)	
Air Pressure Required At Shift Cylinder	70-140 PSI thru 1/4" line
Gear Ratio	2.56:1 speed increase
Input Shaft Rotation	Clockwise (facing gearbox)
Maximum Input Speed	See performance curve page E-1
Input & Output Shaft	heavy duty 2 1/4 inch - 10 spline
Input & Output Flange	1700 Series "dana" flanges
Lubrication	5 U.S. pints (12.36 l) SAE #90 gear lube with 4 fl. oz. (0.12 l) Molykote® M gear guard (Dow Corning)
Approx. Net Weight	234 pounds (106 kg)

**Table 1A. Through Torque Capacity Based On Shaft And Spline Size**

Type Of Engine	Diesel		Gasoline	
	Auto	Manual	Auto	Manual
Transmission				
Torque ft - lbs (max)	6400	6000	8000	7400

**Pump And Mounting Dimensions**

A 40-inch cross member is provided for mounting the output end of the gearbox, and a trunnion mount is provided for the input end. This design provides a flexible three point suspension. The trunnion mount prevents chassis frame twist from being transmitted through the gearbox.

See Figure 1 on page B-3 and Figure 2 Page E-4 for the physical dimensions of the pump and mounting devices.

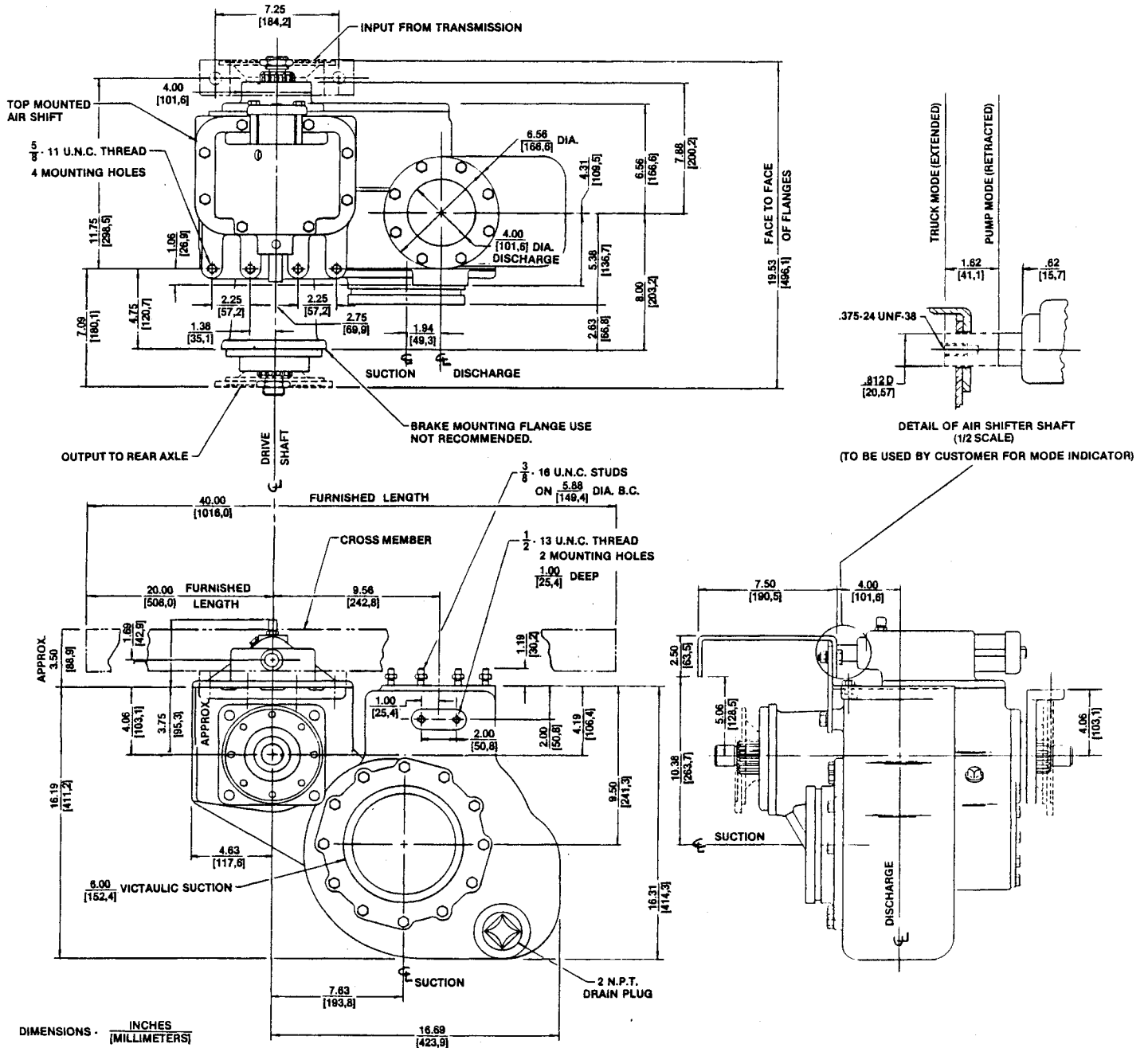

Figure 1. Dimensions Of Pump Model 06C15-GH1

VEHICLE REQUIREMENTS

NOTE

The following instructions apply equally to new installations, rebuilds, or retrofits.

WARNING

```

////////////////////////////////////
//
// After installation, do not attempt to test run or oper- //
// ate the pump and integral gearbox before reading OPERA- //
// TION in Section B. The gearbox was shipped dry of //
// lubricant; lubricate the gearbox as instructed in LUBRI- //
// CATION in Section E before attempting to operate the //
// pump. //
// //
////////////////////////////////////

```

Tank Preparation

It is **essential** that any tank scale, dirt, or other foreign material be removed from the tank and piping prior to pump installation. Failure to do so could result in clogging or damage to the pump.

Vehicle Configuration

If the pump is to be used in tractor-trailer or straight-truck plus trailer service, either a liquid fifth wheel or jumper hoses are required. **Be sure** the drive line of the tractor-trailer is long enough to allow installation of the gearbox at the proper angle, and that jumper hoses are long enough to allow a full turning radius.

Brake Installation

When shifting from vehicle drive to pump mode, or vice versa, drive shaft rotation must be limited to 15 RPM or less to prevent raking of gears. Vehicles with automatic transmissions should be equipped with a brake on the transmission output shaft to stop shaft rotation during shifting of gear box.

Air Cylinder Pressure

For proper operation of the gearbox, air shift device requires vehicle air pressure of 70 to 140 psi. See **Gear Shift Connections** for further information.

---

---

## POSITIONING PUMP

### Lifting

Use lifting equipment with a capacity of a least **1500 pounds**. This pump weighs approximately **234 pounds**, not including the weight of accessories and cross members.

### CAUTION

Due to the confined mounting location, specialized equipment such as a transmission jack with custom brackets should be used to lift and position the pump and gearbox.

### Mounting Location

The following factors must be considered when selecting a mounting location for the pump.

- a. Mounting brackets
- b. Universal joint angles
- c. Shift linkage
- d. Piping
- e. Ground clearance
- f. Accessibility of pump and gearbox for service.

Any damage to the pump or gearbox resulting from improper mounting and installation is **not** covered by the Gorman-Rupp warranty.

### MOUNTING BRACKETS

The rear cross member shipped with the pump can be cut to size to fit the side rails of the vehicle chassis. Use the hardware provided with the pump to rigidly secure the pump and gearbox mounting brackets to the rear cross member (see Figure 2 on page B-6).

When mounted on the pump, the rear cross member **must not** extend over the pump discharge port or in any way impede removal of the pump casing. Proper mounting is critical to access and pump serviceability.

## NOTE

On special applications, the pump and gearbox assembly may be rotated 90° to facilitate installation. When rotated, the pump is **not** self-priming and requires relocation of drain plugs and vents. (Order installation kit 48123-003). Contact the factory or your Gorman-Rupp distributor for more information.

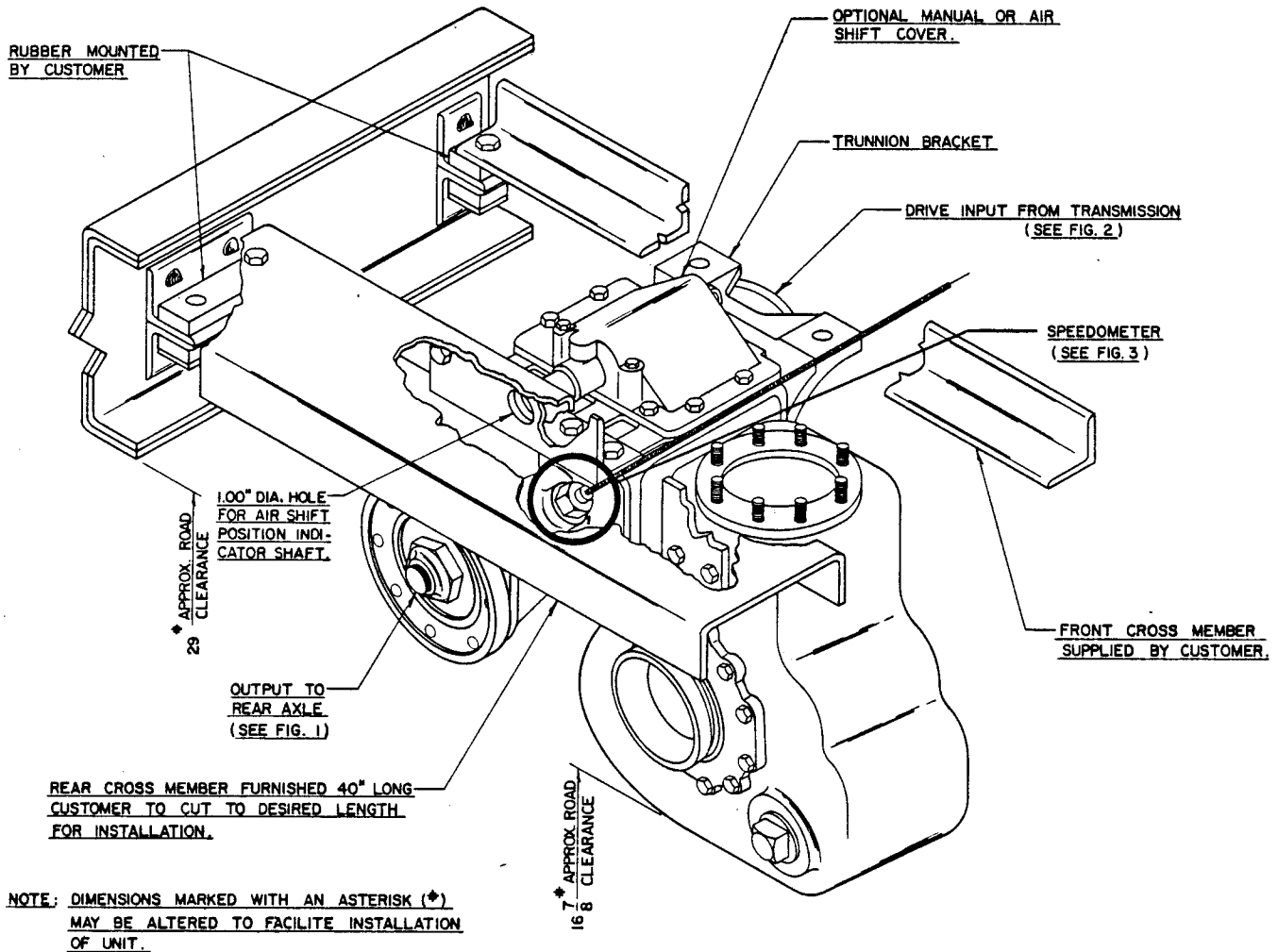

Figure 2. Typical Pump Mounting On Vehicle Chassis

The drive input end of the gearbox is fitted with a trunnion which prevents chassis frame twist from being transmitted through the gearbox. Mount the trunnion to the front cross member (not supplied with pump) to support the drive input end of the pump. When mounting the trunnion, make certain that it will not interfere with the input drive flange. The trunnion mounting foot **must** be directed toward the input flange.

Position the cross members and mounted pump on the side rails of the chassis. The cross members **must** be mounted with rubber or other vibration-dampening material when secured to the side rails.

Do not secure the cross members to the side rails before establishing the exact location and position of the air shift rod and shift indicator connections. Be careful not to put the pump in a bind from front to rear during mounting. Improper alignment could result in bearing or gear failure or gearbox breakage. (See Drive Shaft Alignment).

**DRIVE FLANGE INSTALLATION**

**New Installation**

The pump is shipped with two "Dana" 1700 series drive flanges (see Figure 3) installed on the heavy duty 2 1/4 inch - 10 spline split shaft. The drive flanges will accommodate Spicer, or equivalent universal joints.

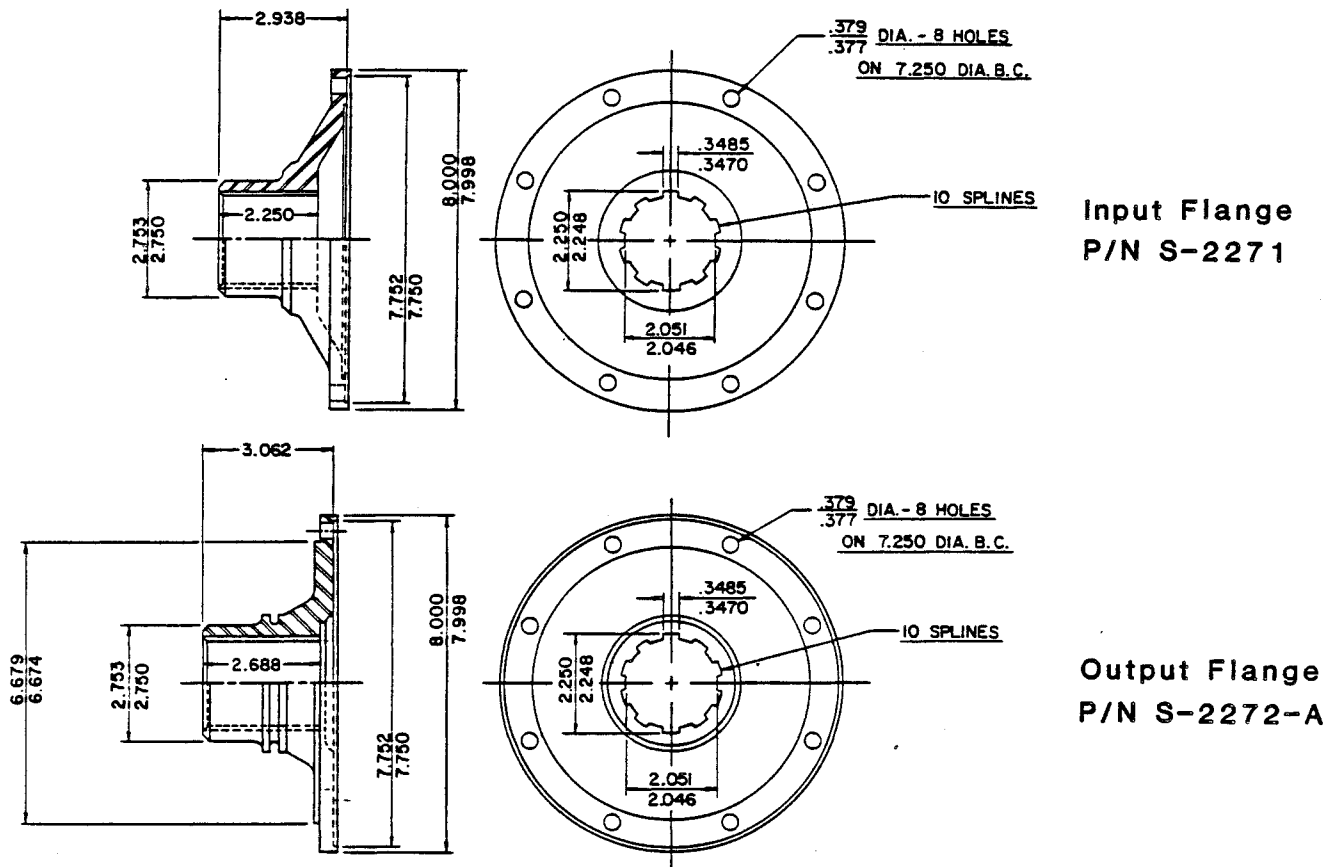

**Figure 3. Drive Flange Dimensions**

The shaft splines are designed to produce a tight interference fit with the drive flange splines. This fit is intentional to eliminate fretting corrosion.

**NOTE**

For detailed instructions on removing and installing the drive flanges, see the specific areas in Section E.

Retro-fit Installation

This pump is furnished with a **heavy-duty** gearbox. Most pumps built before June 1979 were furnished with a **standard-duty** gearbox. The drive flanges mounted on this pump will not accommodate the universal joint assemblies used with previous standard-duty gearbox pumps.

If this pump is to be used as a replacement for a standard-duty gearbox unit, the universal joint to drive flange connections must be modified by installing adaptor flange yokes. These are available from G-R as optional equipment (Kit P/N 48123-001). See Figure 4 installation information.

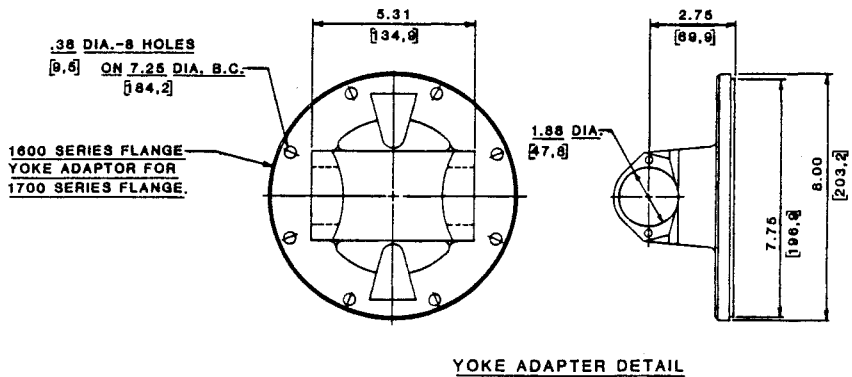
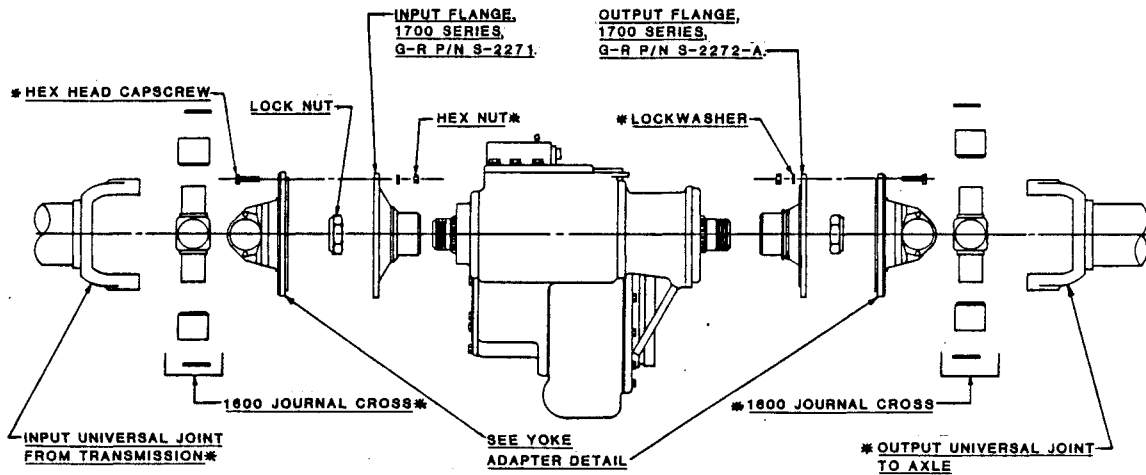

DIMENSIONS: INCHES [MILLIMETERS]

\* INDICATES PARTS SUPPLIED BY CUSTOMER

• Figure 4. Adaptor Flange Yoke For Retro-fit Installation



---



---



---

## DRIVE SHAFT AND LINKAGE CONNECTIONS

### Drive Shaft Alignment

To promote maximum universal joint and bearing life, the universal joint angles must be kept to a minimum. A joint angle of 1 degree is **required** for proper needle bearing circulation, but excessive angles cause accelerated wear and require lower maximum operating speed. (see Table 2).

JOINT ANGLE	MAXIMUM SPEED
5 degrees	5000 RPM
6 degrees, 30 minutes	4000 RPM
8 degrees	3000 RPM

**Table 2. Joint Angle/Maximum RPM**

Align the gearbox with the transmission and the rear axle to obtain the optimum universal joint angles. See Figure 5 on page B-10 for recommended alignment.

### CAUTION

Be certain the rear axle position when vehicle is empty or fully loaded will not cause excessive universal joint angles or cause drive shaft slip joints to bottom out.

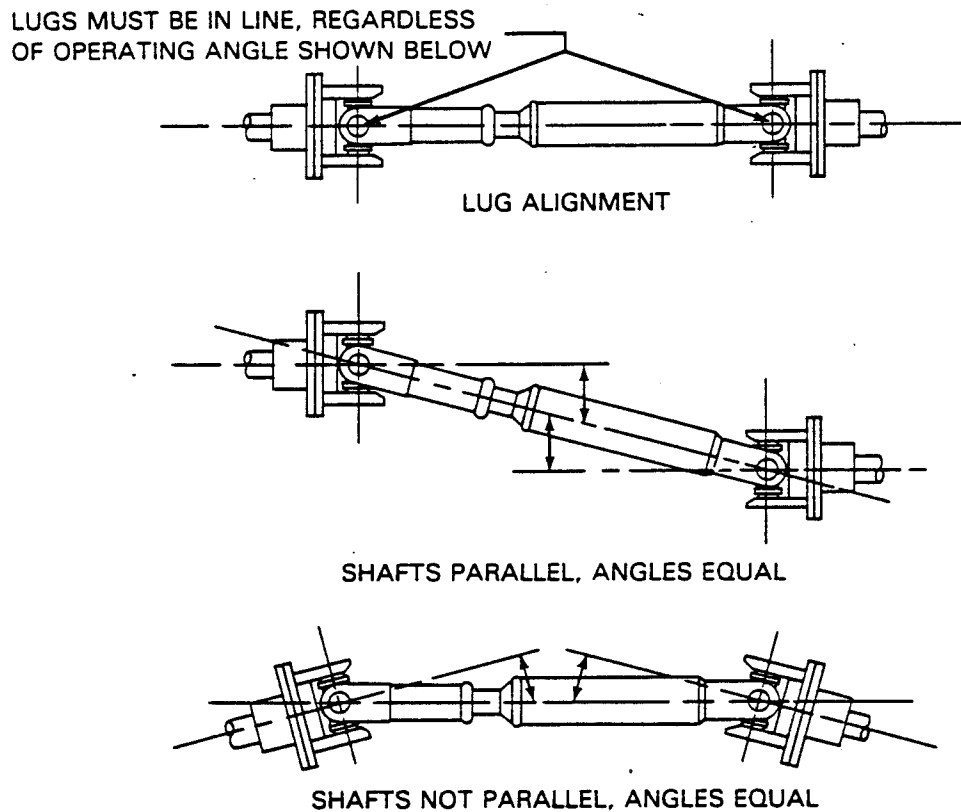

Figure 5. Drive Shaft Alignment

**Make sure** the horizontal and vertical joint angles are equal. Limit the angles to 1 to 3 degrees using a short coupled joint, and less than 8 degrees with a double joint assembly.

#### NOTE

Install a short coupled slip joint on the input side and a double joint with slip on the output side of the gearbox to attain the prescribed angles and eliminate tensile stress on the shaft.

The input and output shafts should be completely subassembled and checked for straightness and balance before installation. Also check the universal joint yokes for proper alignment.

#### Speedometer Connection

The gearbox is fitted with a speedometer adaptor for vehicles equipped with speedometer drive. It is designed to measure truck speed and mileage only. The

adaptor has a 3/16-inch SAE drive, and operates at a 4.66:1 decrease ratio (see Figure 6 on page B-11).

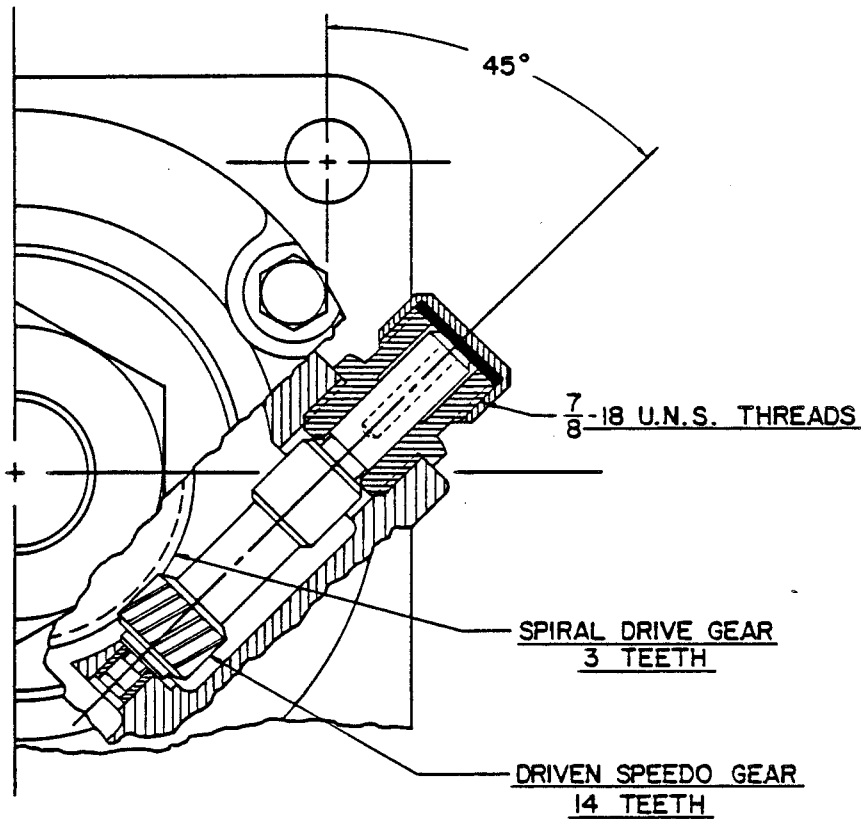

Figure 6. Speedometer Drive Detail

Gear Shift Connections

After the pump is mounted to the chassis, hook up the air shift rod to the proper control stations.

WARNING

```

////////////////////////////////////
// Decals and tags vital to pump operation were shipped //
// loose with the pump. Affix these decals in a prominent //
// place visible to the pump operator. //
// //
////////////////////////////////////

```

Proper operation of the gearbox air shift requires an air cylinder with air pressure of 70 to 140 psi. Use air lines of one-quarter inch. The air line connection at the end cap of the air cylinder is for vehicle operation, and the air line connection at the top of the air shifter cover is for pump operation. Seal all hose fittings with Permatex or equivalent compound.

When actuated, the shifter rod travels through a hole in the rear cross member. A customer supplied shift indicator (mechanical, electrical, or air operated device) should be installed in this area to indicate shifter mode to the pump operator. A tapped hole is provided in the shaft for convenience.

See Figure 7 for approximate shaft travel and hole size.

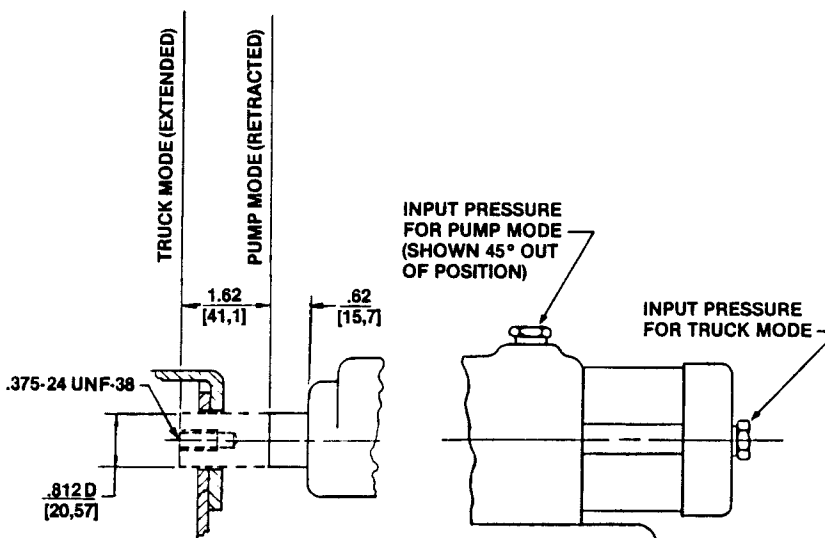

Figure 7. Detail Of Air Shifter Shaft

## SUCTION AND DISCHARGE PIPING

### Typical System Installation

Most petroleum handling vehicles perform both fueling and defueling functions. This requires a system utilizing flow-directing (FDF) valves, eductors, related piping, and safety accessories. Some of the accessories are available from Gorman-Rupp as optional equipment.

See Figure 8 on page B-13 and Figure 9 on page B-13 illustrating typical piping systems used on refueling vehicles.

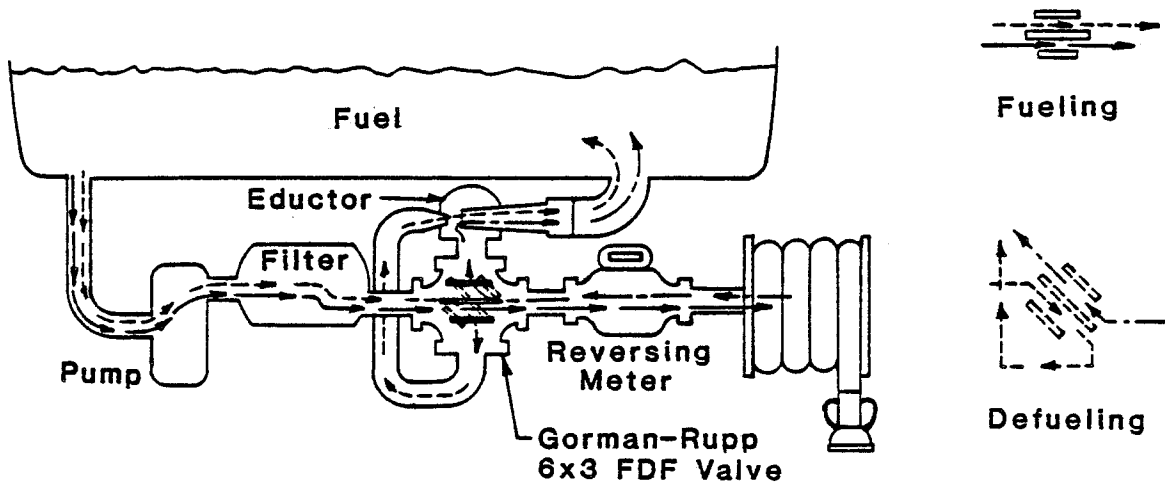
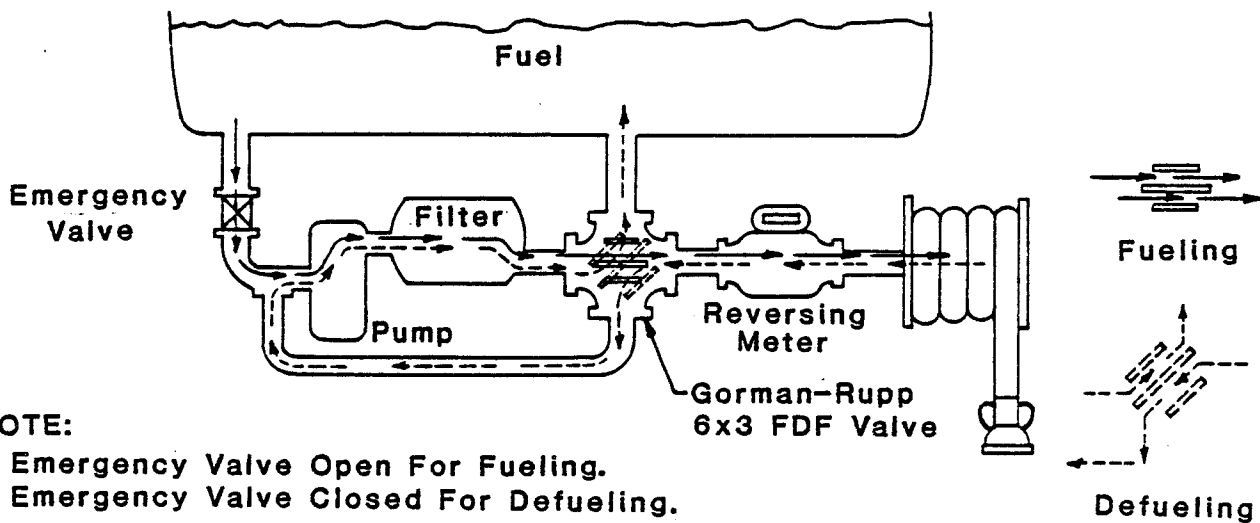

Figure 8. Typical Installation Using Eductor For Defueling And Fueling



**NOTE:**  
 Emergency Valve Open For Fueling.  
 Emergency Valve Closed For Defueling.

Figure 9. Typical Installation Using Pump For Defueling And Fueling

**Piping**

All piping material must be compatible with the liquid being pumped. If hose is used in suction lines, it must be the rigid-wall, reinforced type to prevent collapse under suction.

---

---

Run the 6" suction piping directly from the tank sump to the pump inlet. The suction lines should be as short and straight as possible to minimize friction loss.

#### NOTE

This pump is fitted with a straight-in "victaulic" type suction fitting. An offset suction fitting is available as an option.

The pump discharge is a 4" petroleum flange. The discharge should be mounted vertically just below the top of the chassis frame. It can easily be piped to the filter inlet, discharge manifold, valves, etc..

To avoid wracking, flexible connections such as "victaulic" or bellows **must** be installed at pump suction and discharge.

Do not tighten connecting flanges unless they are properly aligned. Never pull a pipe into place by tightening the flange bolts.

#### VALVES

Gorman-Rupp manufactures several sizes of flow-directing (FDF) valves for use in fueling-defueling operations. The valves are designed to reverse flow of the fuel with only a turn of the valve handle.

#### CAUTION

The FDF valve is designed for directing flow only. DO NOT use as a positive sealing valve.

See Figure 10 on page B-15 and Figure 11 on page B-15 illustrating the installation dimensions and theory of operation for a typical FDF Valve. Consult the factory for further assistance or other sizes.

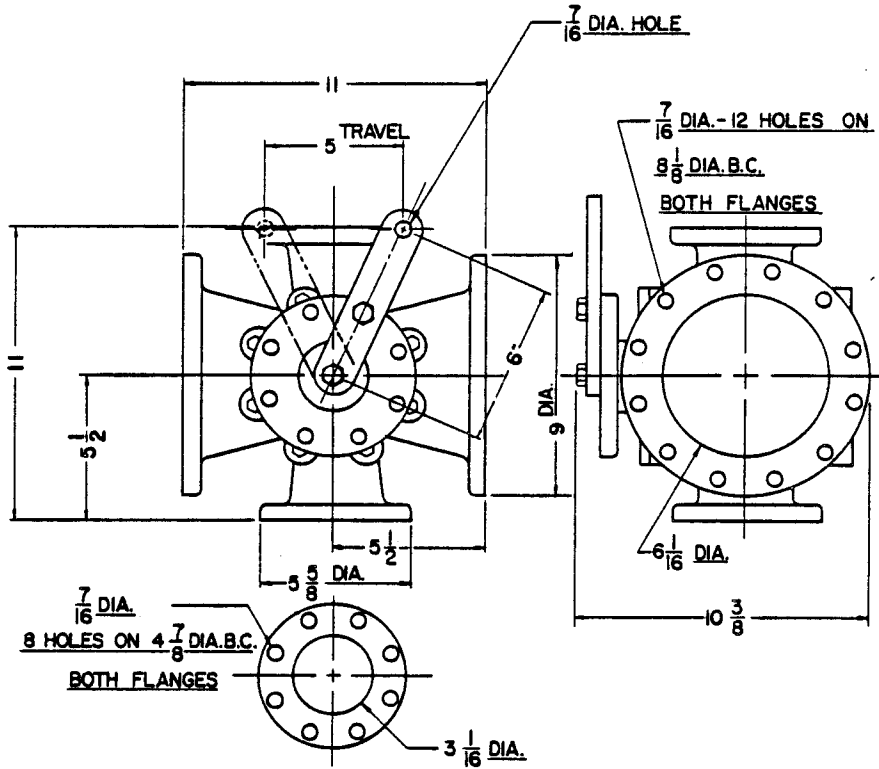
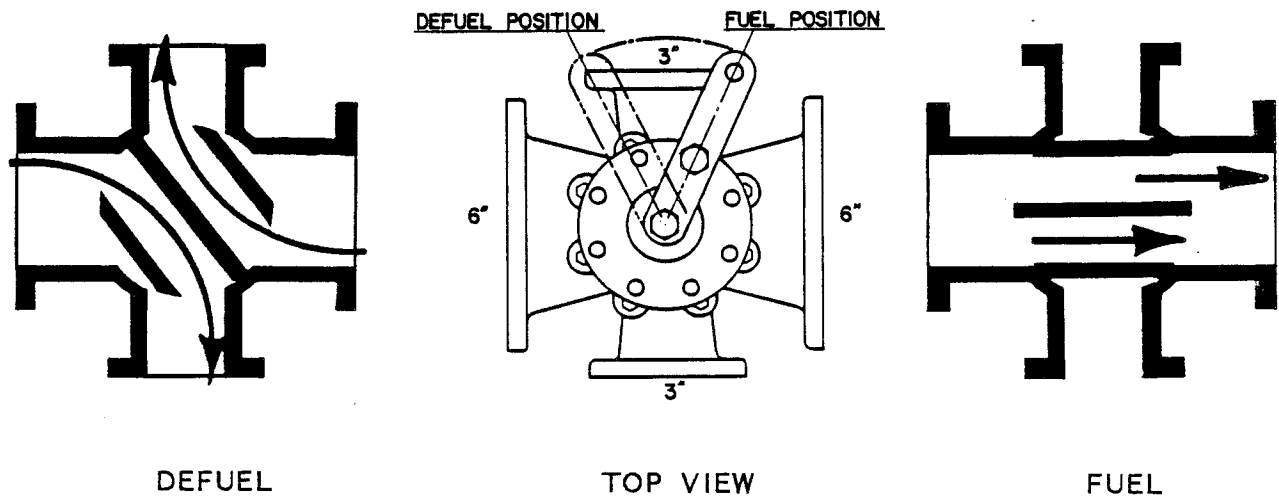

Figure 10. Valve Installation Dimensions

When the center web of the valve is aligned with the 6-inch ports (fueling position) the flow passes straight through. When the handle is turned to the defueling position, the web blocks the straight flow and opens two paths of flow through the 6-inch and 3-inch ports.



DEFUEL

TOP VIEW

FUEL

Figure 11. Theory of Valve Operation

## Eductors

An eductor is used in conjunction with an FDF valve to increase defueling rates and efficiency. An eductor can be used to collapse the service hose and provide hose defueling service.

Contact the Gorman-Rupp Company or an authorized distributor for specifications and performance data.



OPERATION - SECTION C

CAUTION

WHETHER NEW INSTALLATION OR REBUILD OF FUELER, THE FOLLOWING REQUIREMENTS APPLY:

1. It is essential that tank scale dirt and any other foreign elements be removed from tank and piping prior to pump installation.
2. Lubrication has been removed from gearbox prior to shipment from manufacturer. Lubrication must be added before any operation.
3. Pump must not run dry of product at any time.

WARNING

```

////////////////////////////////////
//
// Never tamper with the governor to gain more power. The //
// governor establishes safe operating limits that should //
// not be exceeded. Limit input speed and operating range //
// as indicated on the performance curve. //
// //
////////////////////////////////////

```

PRIMING

Make sure that the piping connections are tight, and that the pump is securely mounted. Check that the pump is properly lubricated (see LUBRICATION in MAINTENANCE AND REPAIR).

This pump is self-priming, but the pump should never be operated unless there is liquid in the pump casing.

CAUTION

Never operate a self-priming pump unless there is liquid in the pump casing. The pump will not prime when dry. Operation of a dry pump will result in rapid heat build-up and destruction of shaft seal faces.

Add liquid to the casing when:

1. The pump is being put into service for the first time.
2. The pump has not been used for a considerable length of time.

- 
- 
- 
3. The liquid in the casing has evaporated.

When installed in a flooded suction application, simply open the system valves and permit the incoming liquid to evacuate the air. After the pump and piping system have completely filled, evacuate any remaining air pockets in the pump or suction line by loosening pipe plug or opening bleeder valves.

Once the casing has been filled, the pump will prime and reprime as necessary.

## GROUNDING

To eliminate electrostatic build-up by the liquid being pumped, the chassis on which the pump is mounted must be grounded by attaching the ground wire assembly to a ground rod. Install the ground rod in accordance with the National Electrical Codes and all local codes. Be sure the clamp or fastener has made a tight electrical connection with the rod.

### CAUTION

Inspect and test the ground wire assembly for conductivity. Replace broken or frayed wire before re-summing operation.

## STARTING

Consult the operations manual furnished with the truck chassis.

### Rotation

The pump input shaft **must** rotate clockwise while facing the shaft. If the pump is operated in the wrong direction, the impeller could become loosened from the shaft and seriously damage the pump.

### CAUTION

Only operate the pump input shaft in a clockwise direction while facing the shaft. Otherwise, the impeller could become loosened from the shaft and seriously damage the pump.

OPERATION

Drive

The entire pump and gearbox assembly is mounted midship between the chassis frame members. The gearbox split shaft replaces a part of the chassis drive shaft connecting the transmission to the rear axle.

Consult the manual furnished with the truck chassis before attempting to start the unit.

OPERATION

WARNING

```

////////////////////////////////////
//
// Do not operate the pump against a closed discharge valve //
// for long periods of time. This could bring the liquid //
// to a boil, build pressure, and cause the pump to rupture //
// or explode. //
// //
////////////////////////////////////

```

The split drive shaft design of the pump gearbox provides for selective operation of either the pump or the vehicle; both cannot be operated at the same time.

Operating Controls

Since Gorman-Rupp has no control over the actual installation, it is the obligation of the tank builder or the installer to devise controls to **safely** operate the pump from inside the cab, or from a remote control panel. All instructions and operational procedures for the pump and system **must** be provided to the pump operator.

WARNING

```

////////////////////////////////////
//
// Decals and tags vital to pump operation were shipped //
// loose with the pump. Affix these decals in a prominent //
// place visible to the pump operator. //
// //
////////////////////////////////////

```

On air shift models, it is strongly recommended that shift mode indicator be visible to the operator.

Shifting Sequence

In shifting to vehicle operation, the air shift rod linkage is activated to engage the output shaft and provide direct drive (1:1 ratio) through the gearbox

OPERATION

to the rear axle of the vehicle.

In shifting to pump operation, activate the air shifter to disengage the gearbox drive output shaft, and to engage the drive input shaft to the gear train which operates the pump. **Never** shift from "drive" to "pump" unless the vehicle is completely stopped.

The pump air cylinder must maintain air pressure of 70 to 140 psi for air shift operation.

At the time of shifting from pump to vehicle operation or vice versa, the power input shaft should be rotating **no more than** 15 RPM. If the vehicle is equipped with a brake on the transmission output shaft, engage the brake before shifting.

CAUTION

When this pump is operated by a diesel engine drive, low idle speed should be increased approximately 200 RPM, or to a speed ensuring even, vibration-free operation of the drive shaft, to prevent excessive wear of components.

Liquid Temperature And Overheating

The **maximum** liquid temperature for this pump is 160° F (71.1° C). Do not apply it at a higher operating temperature.

Overheating can occur if the valves in the suction or discharge lines are closed. Operating against closed valves could bring the liquid to a boil, build pressure, and cause the pump to rupture or explode. If overheating occurs, stop the pump and allow it to cool before servicing it. Refill the casing with cool liquid.

WARNING

Overheating may produce dangerous fumes. Use extreme caution when venting the pump, or when removing covers, plates, plugs, or fittings.

STOPPING

Never halt the flow of liquid suddenly. If the liquid being pumped is stopped abruptly, damaging shock waves can be transmitted to the pump and piping system. Close all connecting valves slowly.

After stopping the pump, secure all pump and system controls to ensure that the pump will remain inoperative.

---

---

## OPERATING CHECKS

### Leakage

No leakage should be visible at pump mating surfaces, or at pump connections or fittings. Keep all line connections and fittings tight to maintain maximum pump efficiency.

### Strainer Check

If a strainer is installed in the pump suction line, check it regularly, and clean as necessary. The strainer should also be checked if pump flow rate begins to drop.

## GEARBOX TEMPERATURE CHECK

The gearbox runs higher than ambient temperatures because of heat generated by friction. Temperatures of approximately 200°F (93.3°C) are considered normal, and can operate intermittently at 250°F (121.1°C).

Checking gearbox temperatures by hand is inaccurate. Place a contact-type thermometer against the housing and record this temperature for future reference.

A sudden increase in gearbox temperature is a warning that the bearings are at the point of failing. Make certain that the bearing lubricant is of the proper viscosity and at the correct level (see **LUBRICATION** in Section E). Bearing overheating can also be caused by shaft misalignment and/or excessive vibration.

When pumps are first started, the bearings may seem to run at temperatures above normal. Continued operation should bring the temperatures down to normal levels within 20 minutes or less.



TROUBLESHOOTING - SECTION D

WARNING

```

////////////////////////////////////
//
// Before attempting to open or service the pump:
//
// 1. Familiarize yourself with this manual.
// 2. Turn off the vehicle ignition to ensure that the
//    pump will remain inoperative.
// 3. Allow the pump to cool if overheated.
// 4. Vent the pump slowly and cautiously.
// 5. Close the suction and discharge valves.
// 6. Check the temperature before opening any covers,
//    plates, or plugs.
// 7. Drain the pump.
//
////////////////////////////////////
    
```

TROUBLE	POSSIBLE CAUSE	PROBABLE REMEDY
PUMP FAILS TO PRIME	Air leak in suction line. Leaking or worn seal or pump gasket. Strainer clogged.	Correct leak. Check pump vacuum. Replace leaking or worn seal or gasket. Check strainer and clean if necessary.
PUMP STOPS OR FAILS TO DELIVER RATED FLOW OR PRES-SURE	Air leak in suction line. Strainer clogged. Impeller or other wearing parts worn or damaged. Pump speed too slow. Discharge throttling valve partially closed; check valve installed improperly. Discharge line clogged or restricted; hose kinked.	Correct leak. Check strainer and clean if necessary. Replace worn or damaged parts. Check that impeller is properly centered and rotates freely. Check driver speed. Check vehicle transmission for slippage. Open discharge valve fully; check piping installation. Check discharge lines; straighten hose.

TROUBLE	POSSIBLE CAUSE	PROBABLE REMEDY
PUMP REQUIRES TOO MUCH POWER	<p>Universal joint drive misaligned.</p> <p>Pump speed too high.</p> <p>Discharge head too low.</p>	<p>Align drive.</p> <p>Check driver speed; check that the universal joint drive is properly installed.</p> <p>Adjust discharge valve.</p>
EXCESSIVE NOISE	<p>Cavitation in pump.</p> <p>Pumping entrained air.</p> <p>Pump or drive not securely mounted.</p> <p>Universal joint drive misaligned.</p> <p>Low or incorrect lubricant.</p>	<p>Reduce discharge pressure and/or pump speed.</p> <p>Locate and eliminate source of air bubble.</p> <p>Secure mounting hardware.</p> <p>Align drive.</p> <p>Check for proper type and level of lubricant.</p>
BEARINGS RUN TOO HOT	<p>Bearing temperature is high, but within limits.</p> <p>Low or incorrect lubricant.</p> <p>Suction and discharge lines not properly supported.</p> <p>Drive misaligned.</p>	<p>Check bearing temperature regularly to monitor any increase.</p> <p>Check for proper type and level of lubricant.</p> <p>Check piping installation for proper support.</p> <p>Align drive properly.</p>



MAINTENANCE AND REPAIR - SECTION E

MAINTENANCE AND REPAIR OF THE WEARING PARTS OF THE PUMP WILL MAINTAIN PEAK OPERATING PERFORMANCE.

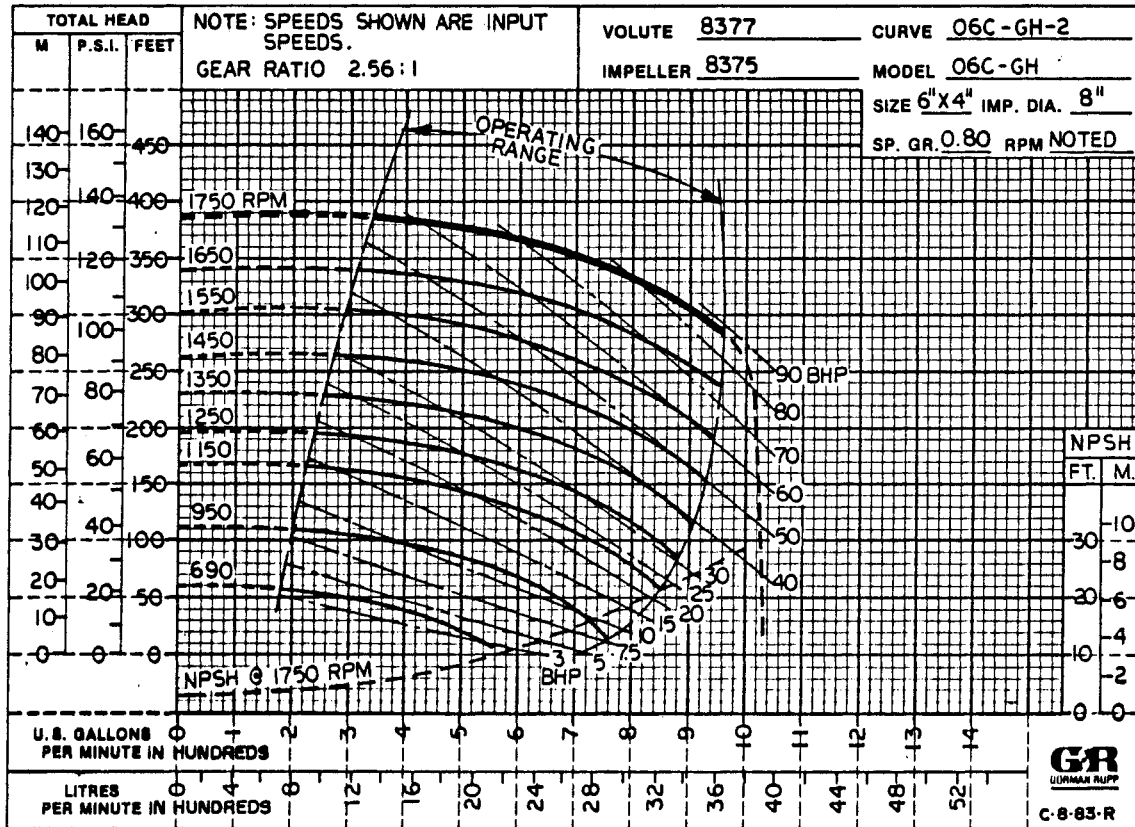

**\*STANDARD PERFORMANCE FOR PUMP MODEL 06C15-GH1**

\*Based on 70°F clear water at sea level with minimum suction lift, corrected to 0.80 specific gravity. Since pump installations are seldom identical, your performance may be different due to such factors as viscosity, specific gravity, elevation, temperature, and impeller trim.

If your pump serial number is followed by an "N", your pump is **NOT** a standard production model. Contact the Gorman-Rupp Company to verify performance or part numbers.

**CAUTION**

Pump speed and operating condition points must be within the continuous performance range shown on the curve. Limit input speeds as specified.

SECTIONAL DRAWING

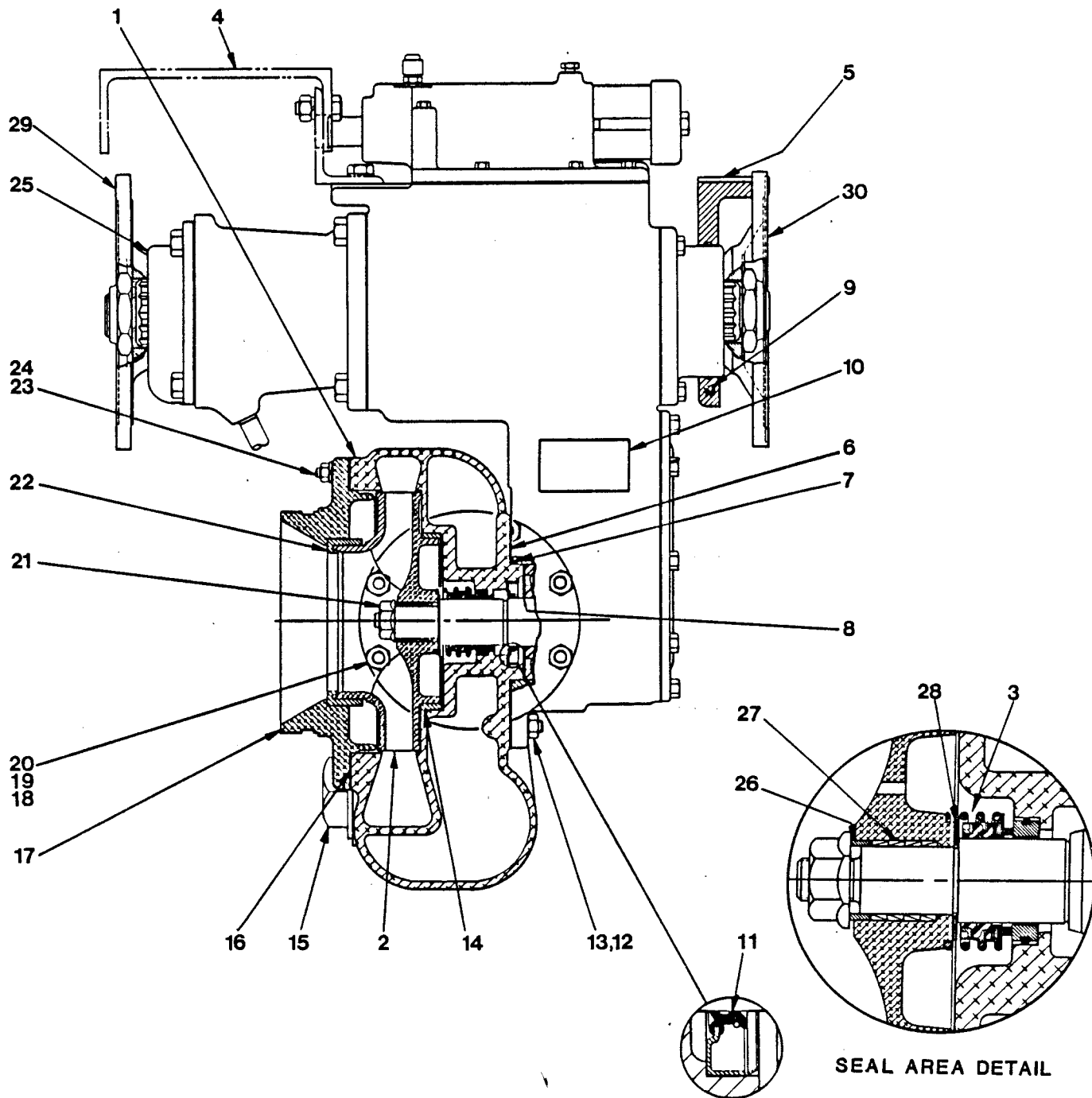

Figure 1. Pump Model 06C15-GH1

**PARTS LIST**  
**Pump Model 06C15-GH1**  
 (From S/N 789501 up)

If your pump serial number is followed by an "N", your pump is **NOT** a standard production model. Contact the Gorman-Rupp Company to verify part numbers.

ITEM NO.	PART NAME	PART NUMBER	MATL CODE	QTY
1	PUMP CASING	8377	13040	1
2	* IMPELLER	38624-507	1304C	1
3	* SEAL ASSY	25271-192	-----	1
4	CROSS MEMBER (SEE FIGURE 2)	8891	-----	1
5	TRUNNION	8767-A	11000	1
6	* PUMP CASING GSKT	8377-G	18000	1
7	* PUMP CASING O-RING	S02085	-----	1
8	* BEARING SHIM SET	8543	15990	1
9	LUBE FITTING	S00186	-----	1
10	NAME PLATE	38818-020	13990	1
11	* OIL SEAL	S02007	-----	1
12	STUD	C00807	15991	6
13	HEX NUT	D00008	15991	6
14	* CASING WEAR RING	8464	10018	1
15	CASING DRAIN PLUG	P00032	11991	1
16	* SUCTION HEAD GSKT	8376-G	20000	1
17	SUCTION HEAD	10218	13040	1
18	* DISCHARGE FLANGE GSKT	5372-G	20000	1
19	STUD	C00606 1/2	15991	8
20	HEX NUT	D00006	15991	8
21	IMPELLER LOCKNUT	S02202	-----	1
22	* SUCTION HEAD WEAR RING	64H5	10018	1
23	STUD	C00605 1/2	15991	12
24	HEX NUT	D00006	15991	12
25	GEARBOX ASSY (SEE FIG. 3 & 3A)	24571-023	-----	1
26	IMPELLER SPACER	31143-059	15030	1
27	LOCKING ELEMENT	24133-025	-----	4
28	IMPELLER SHIM SET	2-X	17090	1
29	OUTPUT COMPANION FLANGE	S02272-A	-----	1
30	INPUT COMPANION FLANGE	S02271	-----	1
NOT SHOWN:				
	DRIVE SCREW	BM#04-03	15990	4
OPTIONAL:				
	MECHANICS FLANGE KIT	48123-004	-----	1
	TRUNNION ASSY	8478	-----	1
	AUXILIARY AIR SHIFTER KIT	S02275	-----	1
	AUXILIARY STUB SHAFT PTO KIT	48123-005	-----	1
	90° GEARBOX ROTATION KIT	48123-003	-----	1

\*INDICATES PARTS RECOMMENDED FOR STOCK

Above Serial Numbers Do Not Apply To Pumps Made In Canada.

CANADIAN SERIAL NO. .... AND UP

SECTIONAL DRAWING

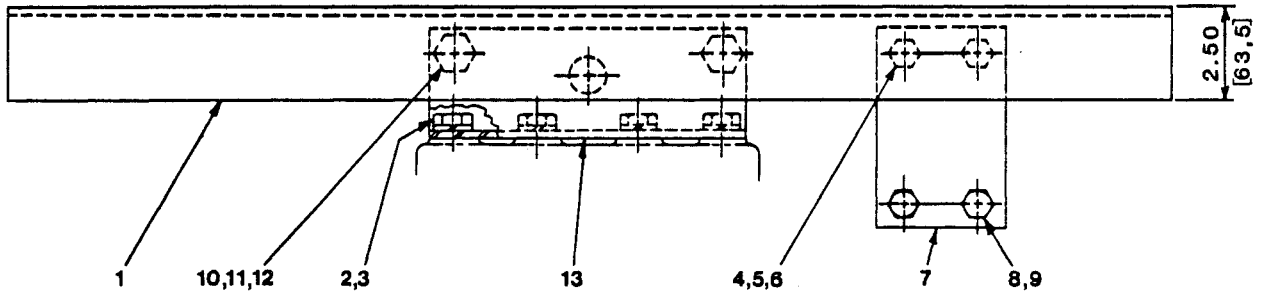

AS VIEWED FROM OUTPUT SHAFT

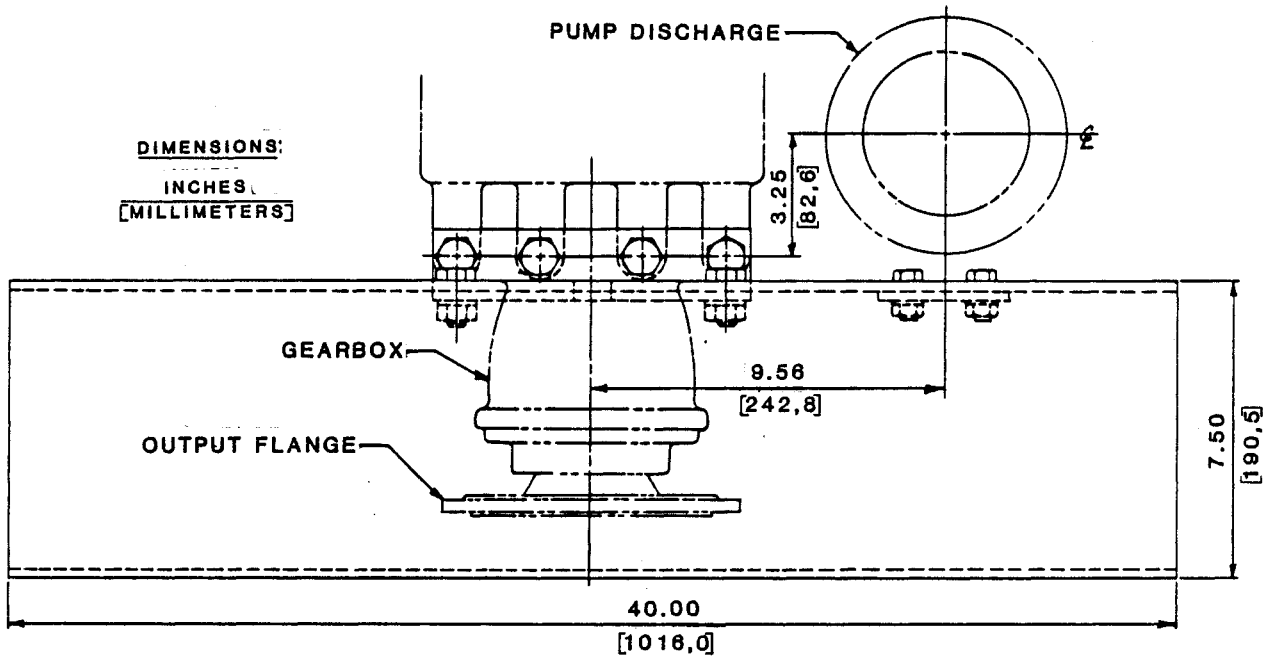

AS VIEWED FROM TOP

Figure 2. Rear Cross Member Assy 8891

PARTS LIST  
Rear Cross Member Assy 8891

ITEM NO.	PART NAME	PART NUMBER	MATL CODE	QTY
1	REAR CROSS MEMBER ASSY	8891	-----	1
2	-HEX HD CAPSCREW	B01004	15991	4
3	-LOCKWASHER	J00010	15991	4
4	-HEX HD CAPSCREW	B00805	15991	2
5	-LOCKWASHER	J00008	15991	2
6	-HEX NUT	D00008	15991	2
7	-PUMP MOUNTING BRACKET	NOT AVAILABLE		1
8	-HEX HD CAPSCREW	B00804	15991	2
9	-HEX NUT	J00008	15991	2
10	-HEX HD CAPSCREW	9016	15990	2
11	-LOCKWASHER	J00010	15991	2
12	-HEX NUT	D00010	15991	2
13	-GEARBOX MOUNTING BRACKET	NOT AVAILABLE		1

\*INDICATES PARTS RECOMMENDED FOR STOCK

SECTIONAL DRAWING

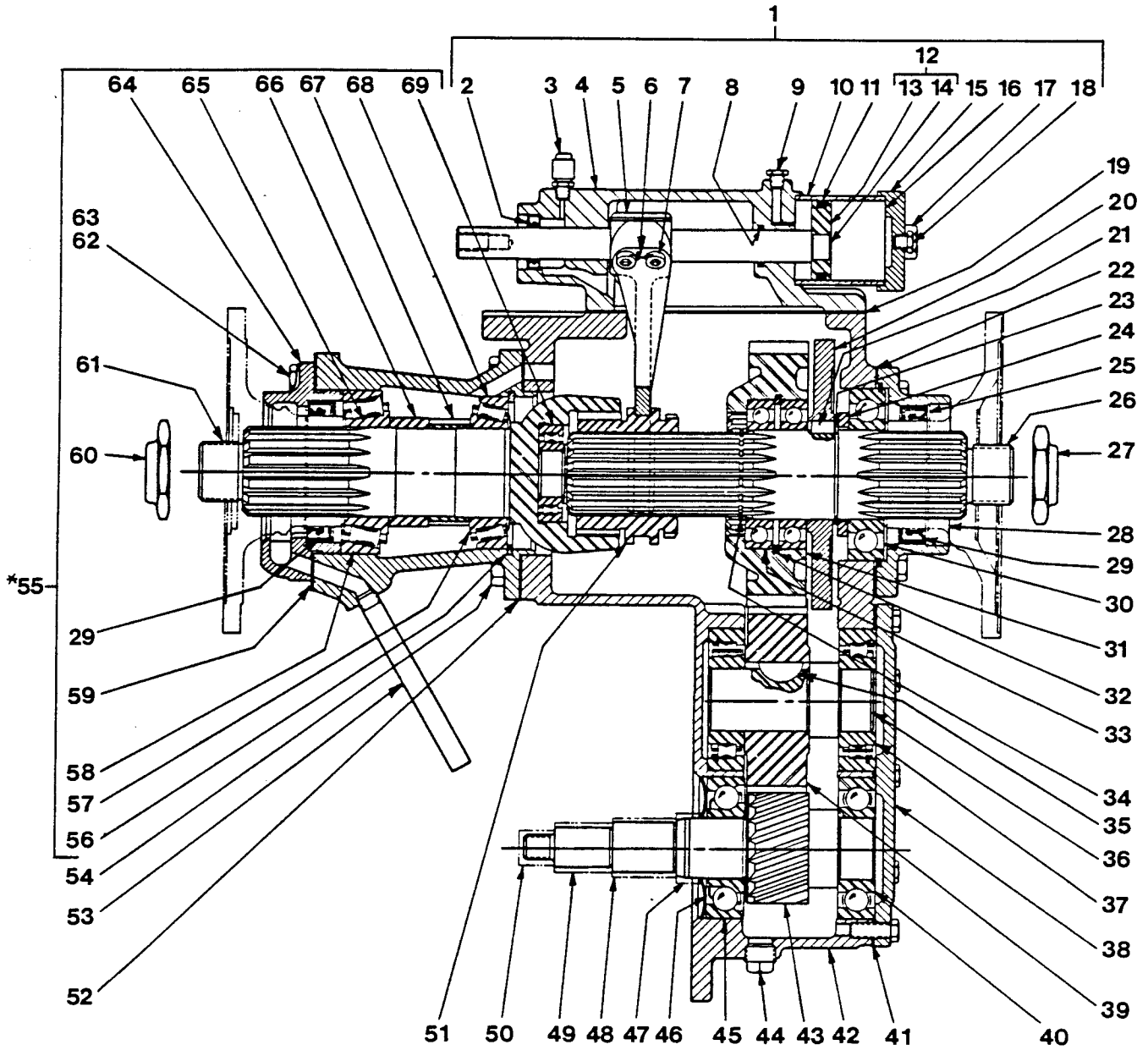

Figure 3. Gearbox Assy 24571-023

PARTS LIST  
Gearbox Assy 24571-023

ITEM NO.	PART NAME	PART NUMBER	MATL CODE	QTY	ITEM NO.	PART NAME	PART NUMBER	MATL CODE	QTY
1	AIR SHIFT CVR ASSY	24571-230	-----	1	37	ROLLER BEARING	24571-081	-----	2
2	-OIL SEAL	24571-168	-----	1	38	BEARING COVER	24571-039	-----	1
3	-PRESS RELIEF FIT	S01530	-----	1	39	IDLER GEAR	24571-073	-----	1
4	-SHIFTER COVER	24571-231	-----	1	40	BALL BEARING	S01080	-----	1
5	-SHIFTER FORK	24571-235	-----	1	41	GASKET	24571-040	-----	1
6	-SAFETY WIRE	24571-165	-----	1	42	HOUSING	24571-030	-----	1
7	-SOCKET HD CAPSCREW	24571-236	-----	2	43	IMPELLER SHAFT	10202-B	-----	1
8	-SHAFT O-RING	24571-214	-----	1	44	PIPE PLUG	PM00008	-----	1
9	-PLASTIC SHIP PLUG	24571-174	-----	1	45	BALL BEARING	23413-209	-----	1
10	-CYLINDER	24571-221	-----	1	46	>SHIPPING COVER	-----	-----	2
11	-PISTON O-RING	24571-215	-----	1	47	>SHIPPING COVER	-----	-----	1
12	-SHAFT/PISTON ASSY	24571-233	-----	1	48	>SHIPPING COVER	-----	-----	1
13	-PISTON	-----	-----	1	49	>SHIPPING COVER	-----	-----	1
14	-SHIFTER SHAFT	-----	-----	1	50	>SHIPPING COVER	-----	-----	1
15	-CYLINDER CAP	24571-222	-----	1	51	SLIDING CLUTCH	24571-077	-----	1
16	-GASKET	24571-203	-----	2	52	GASKET	24571-110	-----	1
17	-HEX HD CAPSCREW	24571-223	-----	2	53	DRAIN PIPE	24571-051	-----	1
18	-PLASTIC SHIP PLUG	24571-174	-----	1	54	HEX HD CAPSCREW	24571-111	-----	4
19	SHIFTER COVER GSKT	24571-036	-----	1	55	TAIL SHAFT ASSY	24571-102	-----	1
20	LUBE GEAR	24571-075	-----	1	56	-RETAINING RING	24571-143	-----	1
21	KEY	N00302 1/2	-----	1	57	-TAPERED BEARING	23765-426	-----	1
22	GASKET	24571-047	-----	1		CONE			
		24571-048	-----	1	58	-TAPERED BRG CUP	23775-028	-----	1
23	RETAINING RING	24571-087	-----	1	59	-SHIMS	24571-117	-----	1
24	SPACER	24571-067	-----	1			24571-118	-----	1
25	SHIPPING COVER	-----	-----	1	60	-LOCKNUT	22568-137	-----	1
26	INPUT SHAFT	24571-061	-----	1	61	-OUTPUT SHAFT	24571-132	-----	1
27	LOCKNUT	22568-137	-----	1	62	-HEX HD CAPSCREW	24571-041	-----	4
28	INPUT BRG CAP	24571-046	-----	1	63	-HY-COLLAR	21171-903	-----	4
29	OIL SEAL	24571-092	-----	1		LOCKWASHER			
30	BALL BEARING	23263-017	-----	1	64	-BEARING CAP	24571-116	-----	1
31	DRIVE GEAR	24571-072	-----	1	65	-TAPERED BEARING	23765-425	-----	1
32	RETAINING RING	24571-088	-----	1		CONE			
33	BALL BEARING	23231-513	-----	2	66	-SPACER	24571-134	-----	1
34	RETAINING RING	24571-085	-----	1	67	-SPEEDO GEAR	24571-152	-----	1
35	WOODRUFF KEY	AV01009	-----	1	68	-TAPERED BRG CUP	23775-331	-----	1
36	IDLER SHAFT	24571-062	-----	1	69	-ROLLER BEARING	23528-002	-----	1

>Items 46, 47, 48, 49, and 50 are provided on repair gearbox assemblies for shipping purposes only. These must be removed before installing the gearbox.

SECTIONAL DRAWING

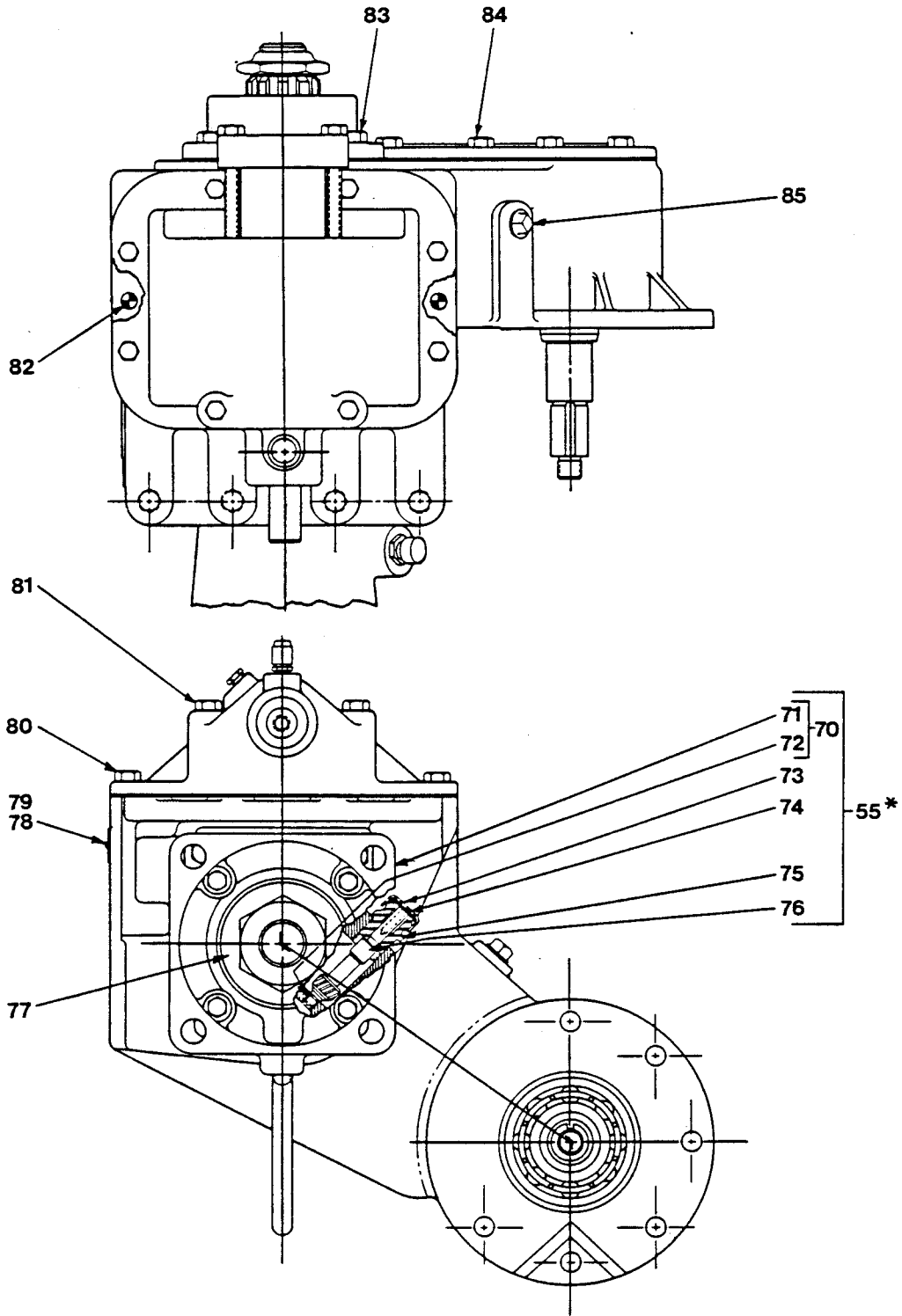

\* Note: See Page E-7 For Description Of Item 55

Figure 3A. Gearbox Assy 24571-023 (Continued)



PARTS LIST  
Gearbox Assy 24571-023 (continued)

ITEM NO.	PART NAME	PART NUMBER	MATL CODE	QTY
70	-BRAKE BRACKET ASSY	24571-106	-----	1
71	-BRAKE BRACKET	NOT AVAILABLE	-----	1
72	-BUSHING	24571-109	-----	1
73	-DUST CAP	24571-155	-----	1
74	-GASKET	24571-156	-----	1
75	-SLEEVE NUT	24571-154	-----	1
76	-SPEEDO GEAR	24571-153	-----	1
77	SHIPPING COVER	-----	-----	1
78	NAME PLATE	-----	-----	1
79	DRIVE SCREW	-----	-----	2
80	HEX HD CAPSCREW	24571-049	-----	6
81	HEX HD CAPSCREW	24571-204	-----	2
82	DOWEL PIN	AA00704	-----	2
83	HEX HD CAPSCREW	24571-049	-----	4
84	HEX HD CAPSCREW	24571-041	-----	8
85	PIPE PLUG	P00008	-----	1

\*INDICATES PARTS RECOMMENDED FOR STOCK

PUMP, SEAL, AND GEARBOX DISASSEMBLY AND REASSEMBLY

Maintenance And Repair

WARNING

```

////////////////////////////////////
//
// Before attempting to open or service the pump:
//
// 1. Familiarize yourself with this manual.
// 2. Turn off the vehicle ignition to ensure that the
//    pump will remain inoperative.
// 3. Allow the pump to cool if overheated.
// 4. Vent the pump slowly and cautiously.
// 5. Close the suction and discharge valves.
// 6. Check the temperature before opening any covers,
//    plates, or plugs.
// 7. Drain the pump.
//
////////////////////////////////////

```

WARNING

```

////////////////////////////////////
//
// After the vehicle is positioned for pump maintenance,
// block the wheels and set the emergency brake before at-
// tempting to disconnect the drive shaft or remove the
// pump. Be sure the pump is properly reinstalled and se-
// cure before operation.
//
////////////////////////////////////

```

The position of the pump unit below the tank and between the frame members of the vehicle chassis provides maximum accessibility to the impeller, wear rings, and seal assembly, the pump parts susceptible to greatest wear. These parts may be serviced with the pump in place on the truck chassis.

If it is necessary to service the gearbox, it is recommended that the entire pump unit be removed from the chassis.

This pump requires little service due to its minimum-maintenance design. If it becomes necessary to inspect or replace components, however, follow these instructions, which are keyed to the sectional views (see Figure 1, 2, 3, and 3A) and the accompanying parts lists.

Pump End Only Disassembly

WARNING

```

////////////////////////////////////
//
// Before operating or servicing the pump, be certain prop- //
// er safety practices are followed. Provide adequate ven- //
// tilation, prohibit smoking, wear static-resistant //
// clothing and shoes. Clean up all fuel spills immediate- //
// ly after occurrence. //
// //
////////////////////////////////////

```

The instructions in this section are keyed to Figure 1 and the accompanying parts list.

Close all valves and remove the casing drain plug (15) to drain the pump. Clean and reinstall the drain plug.

Remove a section of suction piping at the suction head (17). Remove the nuts (24) securing the suction head to the pump casing (1), and remove the suction head. The impeller (2) is now accessible.

To remove the impeller, remove the impeller locknut (21) and spacer (26). The locking elements (27) are not self-locking, and should separate when the impeller locknut and spacer are removed. If the locking elements are jammed and do not separate, loosen by rapping the impeller shaft with a lead mallet or brass bar. **Be careful** not to damage the threads. Inserting a hooked wire in the impeller keyway shaft will aid in removing the elements. After the locking elements have been removed, slide the impeller off the shaft. Use caution when removing the impeller; pressure on the seal spring will be released.

Remove the impeller adjusting shims (28). For ease of reassembly, tag and tie the shims, or measure and record their thickness.

The shaft seal assembly (3) is now accessible. This seal prevents air from entering and liquid from escaping along the impeller shaft. If the gearbox lubricant is contaminated by the product being pumped, the shaft seal and gearbox oil seal (11) have failed and should be replaced.

Remove the seal spring. Use a stiff wire with a hooked end if necessary, to remove the balance of the seal components.

Clean the shaft, the impeller hub bore, and the seal cavity with a soft cloth soaked in solvent.

WARNING

```

////////////////////////////////////
//
// Most cleaning solvents are toxic and flammable. Use //
// them only in a well-ventilated area free from excessive //
// heat, sparks, and flame. Read and follow all prec- //
// autions printed on solvent containers. //
// //
////////////////////////////////////

```

---

---

The presence of gearbox lubricant in the seal cavity indicates failure of the gearbox oil seal (11). Disconnect the discharge piping and drain the gearbox lubricant. Remove the nuts (13) securing the pump casing to the gearbox and separate the assemblies. Tie and tag the bearing adjusting shims (8) for future reference. Remove the old oil seal.

### Pump End Only Reassembly

Replace the gearbox oil seal (11) if defective. It is recommended that a tapered sleeve be installed over the seal area of the shaft to prevent rolling the lip of the oil seal during installation. (See Figure 4 for detail of seal area). Lubricate the oil seal and sleeve to ease installation.

Inspect the casing wear ring (14), which is a press fit in the pump casing. Replace the wear ring if badly scored or worn, taking care not to damage the new wear ring or the pump casing.

### NOTE

The surface finish and clearance between the impeller and wear ring are critical to efficient pump operation. Replace damaged parts which would permit excessive leakage through this close tolerance area.

Align the square hole in the casing gasket (6) with the drainage passage through the pump casing and install it on the casing flange.

Before further reassembly, calculate the thickness of bearing adjusting shims (8) required to obtain a shaft end play of .000 to .005 inch (.000 to .127 mm). Use a micrometer depth gauge to measure the height of the casing pilot (gasket installed) and the distance that the bearing is recessed into the gearbox. Select a combination of shims to make up the difference between the two measurements.

Install the bearing shims into bearing bore and slide the O-ring (7) onto the casing pilot. Secure the pump casing to the gearbox and check the shaft end play. Replace the discharge flange gasket (18), and reinstall the discharge piping.

The seal (3) is not normally reused since wear patterns formed during operation can not be precisely matched during reassembly. Use of an old seal with damaged faces could result in leakage and premature seal failure. Replace the complete seal; **never mix old and new seal parts.**

Remove the new seal from the shipping container and inspect the seal faces for any dirt or foreign matter. Even fingerprints can shorten seal life, cleanliness is essential. Handle all parts with care to prevent damage or contamination.

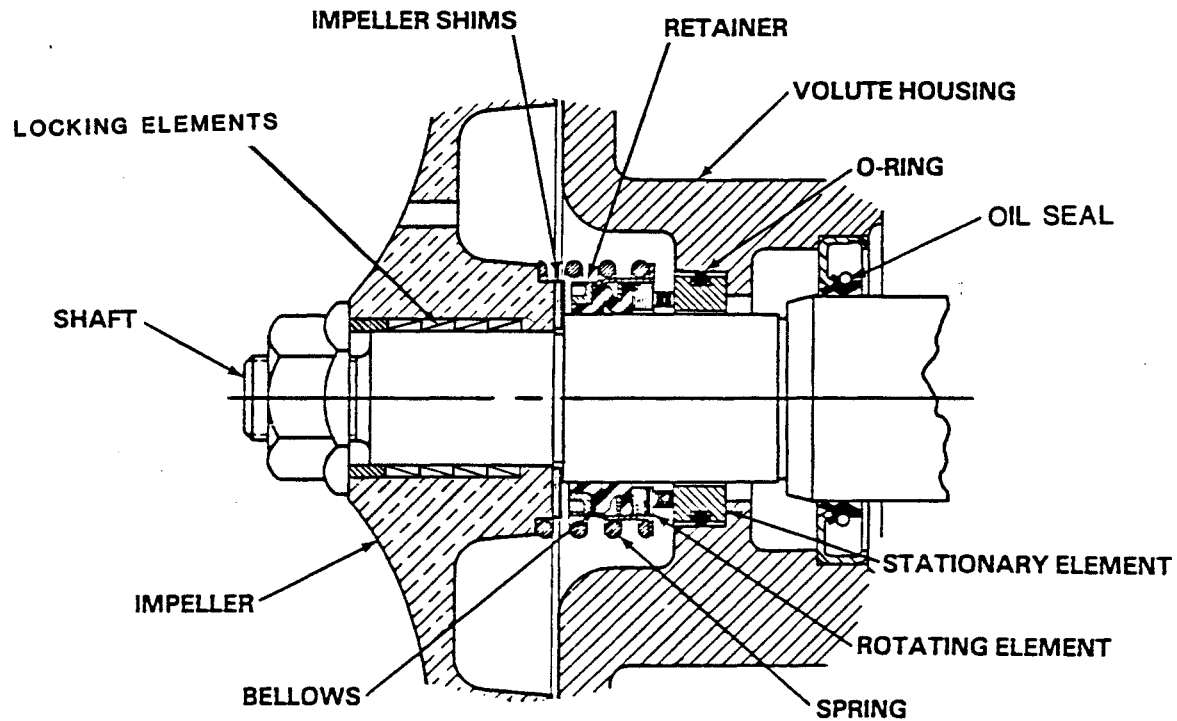

Figure 4. 25271-192 Seal Assembly

## CAUTION

This seal is not designed for operation at temperatures above 160° F (71.1° C). Do not use at higher operating temperatures.

Place a drop of light lubricating oil on the seal faces; **never** use grease. Lubricate the O-ring and install it in the stationary seat. Use thumb pressure to press the seat and O-ring squarely into the seal bore. Be careful not to damage the seal face. Lubricate the shaft bellows with a small amount of light oil, and install the bellows and rotating elements as shown in Figure 4. Install the seal spring, making certain that all components of the seal are seated squarely.

Install the impeller adjusting shims (28). For maximum pump efficiency, the impeller vanes **must** be centered within the volute scroll. The impeller should be correctly centered if the same thickness of adjusting shims are reinstalled as previously removed.

To verify the impeller positioning, measure the pump casing and impeller as shown in Figure 5. Use these measurements to calculate the required impeller location (dimension E). Add or remove impeller adjusting shims until dimension E is obtained.

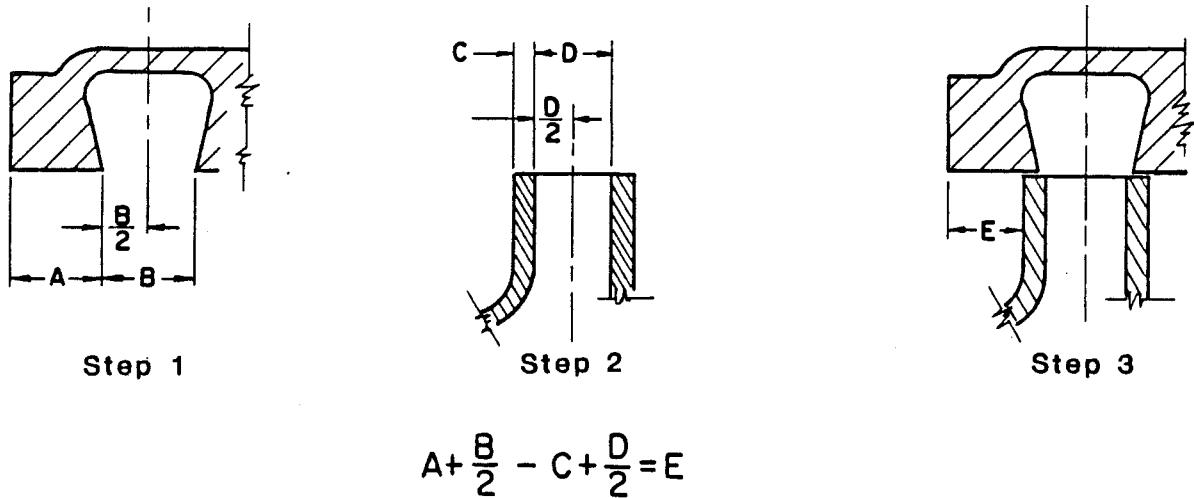

Figure 5. Centering Impeller Within Volute Scroll

NOTE

After the impeller has been properly positioned, check for free rotation. Correct any scraping or binding before further reassembly.

Inspect the impeller, and replace it if cracked or badly worn. Clean and lightly oil the impeller shaft, impeller hub bore, impeller spacer, and locking elements. **Do not** use a molybdenum disulfide lubricant such as "Molykote" or similar lubricants.

Position the impeller on the shaft. The locking elements **must** be installed in inner-ring, outer-ring sequence within the impeller hub bore as shown in Figure 4. It is recommended that a special tool (not furnished by Gorman-Rupp) be used when installing the locking elements; see Figure 6. This tool can be made from 1 1/4-inch O.D. X 7/8-inch I.D. round steel tubing.

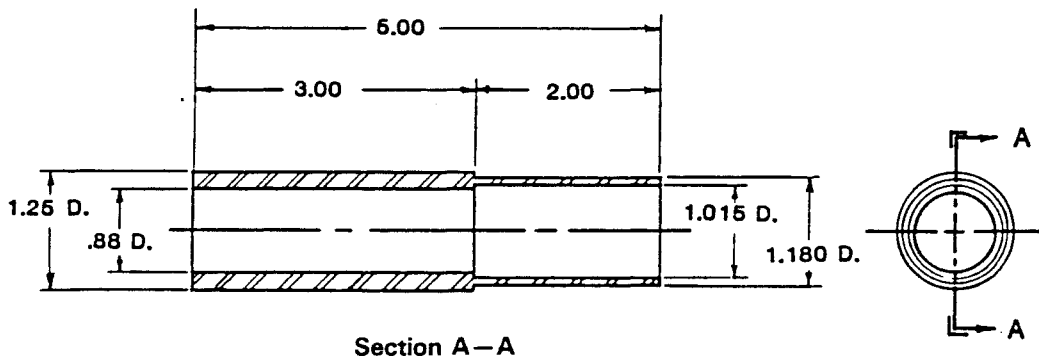

Figure 6. Locking Element Installation Tool

---

---

Using the installation tool, install the first set of elements (inner-ring, outer-ring sequence) into the bore of the impeller so that they seat squarely against the impeller shoulder. Install the next and subsequent sets of elements so that they seat squarely against those previously installed.

When all four set of locking elements are in place, install the impeller spacer and locknut; torque the locknut to 120 ft. lbs.

Inspect the suction head wear ring (22) which is a press fit in the suction head. Replace the wear ring if scored or worn, taking care not to damage the new wear ring or the suction head.

#### NOTE

The surface finish and clearance between the impeller and wear ring are critical to efficient pump operation. Replace damaged parts which would permit excessive leakage through this close tolerance area.

Replace the suction head gasket (16). Apply "Locquic Primer" (grade T) followed by "Loctite" pipe sealant (grade HVV) on the pump housing studs (23) and secure the suction head. Reinstall the suction piping.

Lubricate the trunnion bracket and gearbox as indicated in **LUBRICATION**, Section E. Make certain that all piping connections to the pump are secure. Open all connecting valves and make certain that there is a supply of liquid to the pump before starting the pump.

#### GEARBOX DISASSEMBLY

When the pump is properly operated and maintained, the gearbox should not require disassembly. Disassemble the shifting mechanism, shafts, and bearings **only** when there is evidence of wear or damage.

#### CAUTION

Gearbox disassembly in the field is not recommended. These operations should be performed only in a properly-equipped shop by qualified personnel.

The instructions in this section are keyed to Figure 3 and 3A and the accompanying parts lists.

#### Removing Pump Unit

Close all valves in the piping system, drain the pump, and disconnect the suction and discharge piping (see **Pump End Only Disassembly**).

Remove the drain plug (44) to drain the gearbox. Clean and reinstall the drain plug.

---

---

Disconnect the air shift linkage from the shifter shaft (14).

Disconnect the input and output companion flanges at their respective universal joints.

Remove the hardware securing the trunnion to the front cross member, and the hardware securing the pump and gearbox mounting flanges to the rear cross member. Remove the pump and gearbox assembly from the vehicle chassis.

#### CAUTION

Due to the confined mounting location, specialized equipment such as a transmission jack with custom brackets should be used to lift and position the pump and gearbox.

#### Air Shift Cover Disassembly

To remove the air shift cover assembly (1), disengage capscrews (80 and 81) securing the assembly to the gearbox housing (42).

The air supply lines and cylinder cap (15), must be removed before the shaft and piston assembly (12) can be removed. To remove the cylinder cap, disengage the capscrews (17).

To remove the shifter fork (5), remove the lock wire (6) installed on the allen screws (7) securing the fork to the shifter shaft. Disengage the screws and remove the shifter fork.

Remove and inspect the shaft (14), piston (13), and piston O-ring (11), replacing as necessary. Remove oil seal (2) and shaft O-ring (8).

#### Drive Flange Removal

Disengage the locknuts (27 and 60) securing the input and output companion drive flanges to their respective shafts, and remove the flanges, using a suitable puller.

#### NOTE

After the flanges have been removed, reinstall the locknuts to protect the shafts' threads.

#### Output Shaft Disassembly

To remove the tail shaft assembly (55), which includes the output drive shaft (61) and all related components, remove the capscrews (54) securing the assembly to the gearbox housing.



---

---

Remove capscrews (62) securing the bearing cap (64) and shims (59) to the brake bracket (70). Tie and tag the bearing shims for future reference. Inspect the oil seal (29) and replace it if necessary.

If the output shaft (61) is to be removed from the tail assembly, first remove the speedo gear (76) by disengaging the sleeve nut (75). Continue to disassemble the remaining parts from the shaft.

### Input Shaft Disassembly

To remove the input drive shaft (26), remove capscrews (83) securing the bearing cap (28) and gasket to the gearbox housing. Inspect the oil seal (29), and replace it if necessary. Remove the ball bearing (30), spacer (24), and lube gear retaining ring (23).

Remove the sliding clutch (51). Pull the input shaft from the housing and reach through the top of the gearbox to remove the drive gear assembly (31), lube gear (20), and gear key (21). The ball bearings (33) and retaining ring (32) can be removed from the drive gear. Retaining ring (34) need not be removed from the shaft unless the shaft is to be replaced.

### Idler Shaft Disassembly

Disengage the hardware securing the bearing cover (38) to the gearbox housing, and remove the cover. Remove the front roller bearing (37). There is a tapped hole (3/4-10 UNC X 5/8 deep) at the end of the idler shaft (36) to accommodate a puller. Pull the shaft and shaft key (35) through the idler gear (39). Remove the idler gear through the top of the gearbox. Remove the rear roller bearing from the gearbox cavity.

### Impeller Shaft Disassembly

With the pump end disassembled (see **Pump End Only Disassembly**) and idler shaft removed, the impeller shaft (43) and bearings (40 and 45) can be tapped out from either side of the gearbox.

### Gearbox Reassembly

Clean all component parts (except bearings) with a soft cloth soaked in cleaning solvent, and dry thoroughly.

WARNING

```

////////////////////////////////////
//
// Most cleaning solvents are toxic and flammable. Use //
// them only in a well-ventilated area free from excessive //
// heat, sparks, and flame. Read and follow all prec- //
// autions printed on solvent containers. //
// //
////////////////////////////////////

```

Inspect all parts for wear, and replace as necessary. Check all oil seal seating surfaces for nicks and scratches. Dress small nicks and burrs with crocus cloth. Be careful not to distort the shape of the surface.

To prevent contamination, wash the bearings separately in **fresh** cleaning solvent. Dry the bearings with filtered compressed air and coat with light oil. **Do not** spin the bearings using compressed air.

Rotate the bearings by hand to check for roughness or binding, and inspect the bearing balls. If rotation is rough or the balls discolored, replace the bearings.

CAUTION

<p>Bearings must be kept free of all dirt and foreign material. Failure to do so will greatly shorten bearing life. <b>DO NOT</b> spin dry bearings. This may scratch the rollers or races and cause premature bearing failure.</p>
---

When reassembling the gearbox, replace all gaskets and O-rings. Apply a light coat of oil on mating surfaces of shaft, gears, and oil seals to ease reassembly.

Idler Shaft Reassembly

NOTE

Position the gearbox housing (42) so that the bearing cover (38) opening faces up. Rest the housing on wooden blocks while in the position.

Install rear roller bearing (37) so that the shoulder of the outer race is snug against gearbox (42).

Reach through the top of gearbox and lay the idler gear in position next to the rear bearing. Install the woodruff key (35) in the idler shaft (36) and push the shaft through idler gear into rear bearing. Make certain the idler gear is engaged by the key. The shaft shoulder should be snug against the gear shoulder and the gear should be snug against the bearing.

---

---

Install the front roller bearing (37) so that the shoulder of the inner race is snug against the shaft shoulder.

#### NOTE

When installing the bearings onto the shaft, **never** press or hit against the outer race, balls, or ball cage. Press **only** on the inner race.

#### NOTE

When installing the shaft and bearings into housing push against the outer race. **Never** hit the balls or ball cage.

### Impeller Shaft Reassembly

Press the front bearing (40) onto the impeller shaft (43) and install this assembly in gearbox housing (42). Leave bearing slightly higher than gearbox surface so bearing will be pressed in to proper position by bearing cover (38).

Replace bearing cover gasket (41) and secure the bearing cover (38) the gearbox housing.

#### NOTE

Reposition the gearbox housing assembly so that the input shaft opening faces down. Place a block under the input bearing flange area to level and add support during further assembly.

Install rear impeller shaft thrust bearing (45) onto shaft so that the printing on the **outer** race (wide side) faces **away** from the impeller shaft gear and the printing on the **inner** race (wide side) faces **toward** the gear. Press firmly on the inner and lightly on the outer race until the inner race seats against the gear. Should the outer race separate from the bearing, remove the inner race from the shaft and carefully reinstall the outer race over the balls using firm, steady pressure. Reinstall the bearing on the shaft. Temporarily cover the bearing to protect it from dirt and dust.

### Input Shaft Reassembly

Before installing the input shaft, position lube gear (20) in the gearbox with the raised hub next to the drive gear bearing.

Install bearing (33), retaining ring (32), and the second bearing (33) in the drive gear (31). Position the drive gear assembly in gearbox with the exposed bearing next to the lube gear.

---

---

### NOTE

Be certain all retaining rings are fully seated in their respective grooves.

Install the bearing retaining ring (34) in the proper groove of the input shaft (26). Push the sliding clutch (51) over the long splined end of the input shaft. The narrow row of teeth must face toward the retaining ring. Check for free movement by sliding the clutch back and forth over full length of spline. Install the roller bearing (69) on the input shaft.

Protect the threaded end of the input shaft and tap the assembly through the drive gear assembly and lube gear until the retaining ring (34) rest on the drive gear bearing. Again, check for free clutch movement and proper engagement with drive gear.

If the tail shaft assembly is fully assembled, it may be installed at this time using new gasket (52). Take care to align input shaft bearing (69) in the bell shaped end of the output shaft.

### NOTE

Reposition gearbox assembly on its side providing access to shaft through shifter cover opening.

Install the lube gear drive key (21). Install retaining ring (23) so that the ring opening does not line up with the lube gear key. Install spacer (24) and bearing (30). Be sure the drive gear is in mesh with the idler gear. Again, check to be sure the clutch slides freely and properly engages both the drive gear and the output shaft (if installed).

Install the oil lip seal (29) in the input bearing cap (28) and secure it to the gearbox housing.

### Output Shaft Reassembly

To assemble the output shaft, press the bearing cup (68) into the brake bracket (71) from the gearbox end until it is just passed the retainer ring groove. Install the retainer ring (56). From the opposite side, tap the bearing cup into place until it seats evenly on the retainer ring. Insert the tapered bearing cone (57) from output end, seating it into the bearing cup.

With the brake bracket setting on the gearbox end, stack the speedo gear (67), spacer (66) and bearing cone (65) onto bearing cone (57). Press bearing cup (58) into the bore to hold the other stacked parts in place. In order to install the output shaft (61), the brake bracket assembly must be turned to the opposite end. Apply pressure on the bearing cone (65) to hold the stacked parts in place, and **carefully** revolve the assembly. Check the alignment of all parts.

Press output shaft through bearings and other stacked parts (threaded end first) until the shoulder seats on the bearing cone (57).

Tap the bearing cup (58) in evenly to ensure it is in full contact with bearing cone (57). Use a depth micrometer to measure the distance from housing flange to bearing cup, at four different locations around the bearing bore. This di-

---

---

mension should be the same at all four readings indicating that the cup is square with shaft. Square the bearing as required.

Before further reassembly, calculate the thickness of bearing adjusting shims (59) required to obtain a bearing preload of .000 to .002 inch (.000 to .051 mm). Use the micrometer depth gauge to measure the length of the bearing cap pilot (64) and the distance the bearing cup (58) is recessed into the bearing bore. Select a combination of shims to make up the difference between these two measurements.

After proper shimming is determined, install the oil seal (29) and secure the shims and bearing cap (64) to the brake bracket. Be sure the vent holes in the bearing cap and shims are aligned with the passage way in the brake bracket.

#### NOTE

Temporarily install two 3/8 - 16 UNC X 2" long studs in the brake bracket capscrew holes to aid alignment and bearing cap installation.

If the speedo drive was removed, reinstall it.

If the input shaft has been installed, secure the tail shaft assembly to the gearbox housing using a new gasket (52). Be sure the input shaft bearing seats properly in the output shaft bearing bore.

Disengage the sliding clutch from the output shaft and turn the shaft by hand. No drag or play should be evident in the output shaft or bearings. Recheck the bearing cap shims, adding or subtracting shims as required to make necessary adjustment.

#### Drive Flange Reassembly

The shaft splines are designed to produce a slight interference fit with the drive flange splines. This fit is intentional to eliminate fretting corrosion.

Coat input and output shaft splines with oil. Apply oil to leading area of drive flanges where oil lip seats as well as the spline. Position input and output drive flanges on their respective shafts.

It is recommended that a sleeve be used to drive the flanges onto the shaft until fully seated. The sleeve must be sized to fit over the shaft and into the flange counterbore (2 1/4-inch I.D. X 7/8-inch O.D. sleeve recommended).

After the flanges have been installed and fully seated, install the locknuts and torque to 500 ft. lbs..

#### Air Shift Cover Reassembly

Reinstall the shifter shaft O-ring (8), and oil seal (2). Be sure the lip of the oil seal is pointing toward the shifter fork. Replace the plunger O-ring (11). Lubricate the O-rings, piston and cylinder I.D. with "Parker-O-Lube" and reinstall the shaft and piston assembly (12). Secure the cylinder cap by tight-

ening capscrews (17). With equal pressure to prevent cocking the cylinder body and torque to 35 ft. lbs. Check for free movement of the shaft and piston.

Inspect the shifter fork and replace as necessary. Position the shifter fork on the shaft and in the shifter cover, and secure the fork to the shaft by tightening the allen screws to 40-45 ft. lbs. Reinstall the lock wire securing the allen screws.

Engage the shifter fork with the sliding clutch, and secure the air shift cover to the gearbox housing.

Apply "Permatex" on the hose fittings before installing the air supply lines to the air cylinder. Check all possible leak points with 120 to 150 psi before further reassembly.

Check shifter fork and sliding clutch alignment by working the shifter fork back and forth. The shaft should travel 1.625 inches between the two positions.

If the pump end only was removed, reinstall it (see **Pump End Only Reassembly**).

**Reinstalling Pump Unit**

Secure the trunnion bracket, and the pump and gearbox mounting flanges, to the front and rear cross members respectively. Position the mounted pump on the vehicle chassis side rails.

**WARNING**

```

////////////////////////////////////
//                               //
// Use lifting and moving equipment in good repair and with //
// adequate capacity to prevent injuries to personnel or //
// damage to equipment. //
//                               //
////////////////////////////////////

```

For installation of piping, transmission linkage, and installation and alignment of universal joints and drive shafts, see Section B.

**LUBRICATION**

**Pump Shaft Seal**

The seal assembly is lubricated by the liquid being pumped, and no additional lubrication of the seal is necessary.

Trunnion Bracket

To lubricate the trunnion (5) and the bearing retainer, add No. 2 lithium-based pressure gun grease through the lubrication fitting (9) until grease escapes from the trunnion area.

Gearbox Assembly

WARNING

```

////////////////////////////////////
//
// This pump is shipped from the factory dry of gearbox //
// lubricant. The gearbox must be lubricated before the //
// pump is operated. //
// //
////////////////////////////////////

```

NOTE

Dow Corning Molykote M Gear Guard is added to the gearbox at the factory after the pump has been tested and the gearbox has been drained. It is recommended that 4 ounces (0.12 l) of Molykote® M Gear Guard, or equivalent gear lube, be added to the gearbox at each lubrication change.

Remove the gearbox fill plug (85, Figure 3), and add 5 pints (2.36 l) - or fill until the fill plug opening overflows - of a premium quality, multi-purpose, extreme pressure gear lubricant with an SAE rating per the following ambient temperatures:

SAE No. 80	Below 40° F/4° C
SAE No. 90	From 40° F/4° C to 100° F/38° C
SAE No. 140	From 100° F/38° C to 150° F/66° C

Multi-grade lubricants such as 80 W 140 are also suitable.

Change the lubricant in a new gearbox after an initial break-in period of 24 hours, and before 100 hours of operation. The lubricant should be changed while the pump is at operating temperature. Remove the magnetic drain plug (44, Figure 3) to drain the gearbox. Always clean the magnetic plug thoroughly before reinstalling it.

After the initial change, the lubricant should be changed every 500 hours of operation or every six months, whichever comes first. The lubricant should be changed more frequently when the pump is operating under severe conditions, such as in heavily dusty atmospheres or in areas of temperature change.

Check the oil in the gearbox monthly, and maintain it at the proper level. A monthly check of the gearbox for leaks is also recommended.

**NOTE**

Contaminated gearbox lubricant or metal chips on the magnetic drain plug may indicate impending pump or gearbox failure. Monitor operation closely and schedule maintenance accordingly.





**For U.S. and International Warranty Information,  
Please Visit [www.grpumps.com/warranty](http://www.grpumps.com/warranty)**

**or call:**

**U.S.: 419-755-1280**

**International: +1-419-755-1352**

**For Canadian Warranty Information,  
Please Visit [www.grcanada.com/warranty](http://www.grcanada.com/warranty)**

**or call:**

**519-631-2870**

**THE GORMAN-RUPP COMPANY • MANSFIELD, OHIO**

**GORMAN-RUPP OF CANADA LIMITED • ST. THOMAS, ONTARIO, CANADA**