

INSTALLATION, OPERATION, PARTS LIST,  
AND MAINTENANCE MANUAL

---



OM-01252-0P01

Q

March 17, 1982

Rev. A

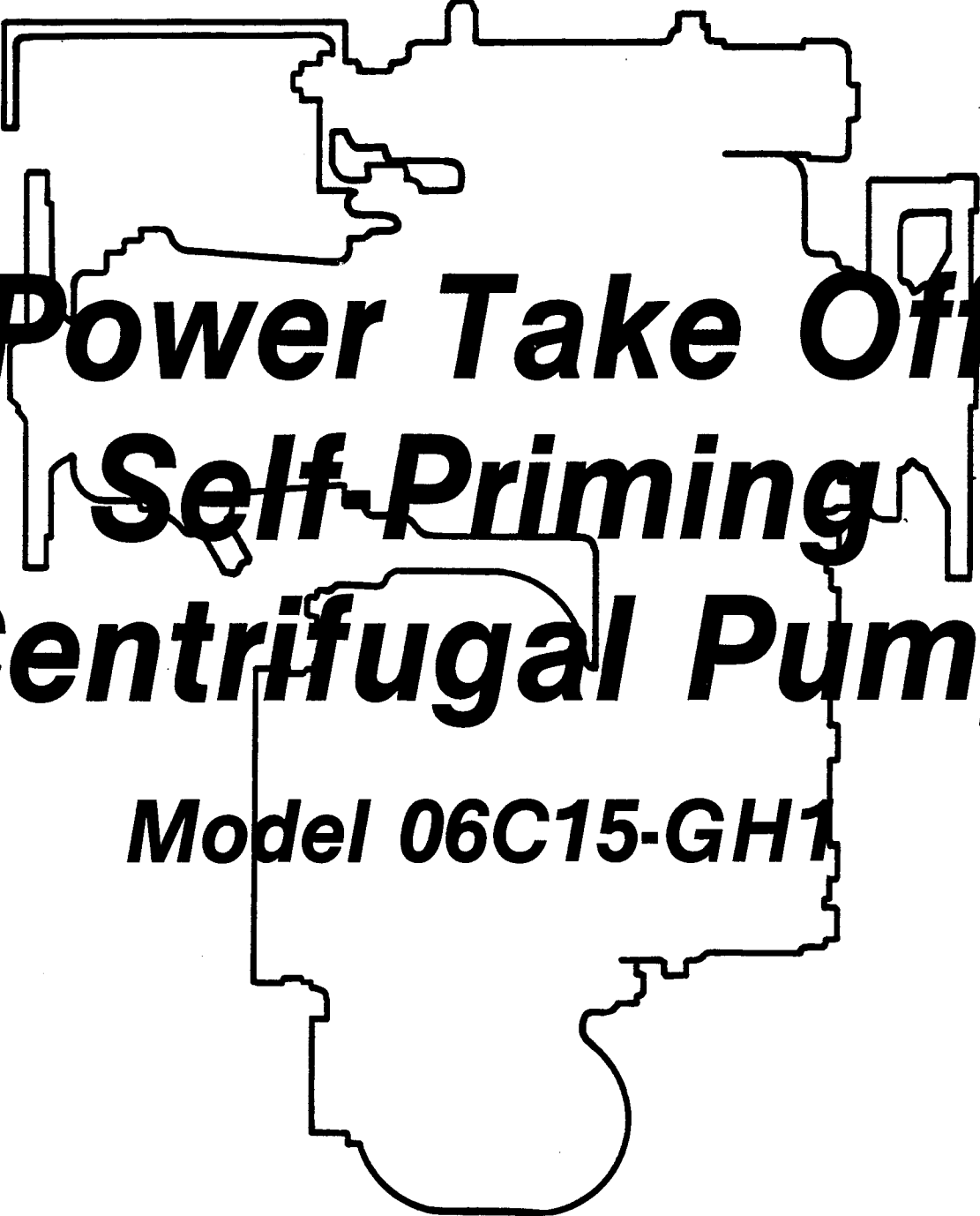
A large, black outline of a pump housing, serving as a background for the title text. The outline shows the main body of the pump, including the inlet and outlet ports.

***Power Take Off  
Self-Priming  
Centrifugal Pump  
Model 06C15-GH1***

THE GORMAN-RUPP COMPANY • MANSFIELD, OHIO  
GORMAN-RUPP OF CANADA LIMITED • ST. THOMAS, ONTARIO, CANADA Printed in U.S.A.

Copyright by the Gorman-Rupp Company



This Installation, Operation, and Maintenance Manual is designed to help you get the best performance and longest life from your Gorman-Rupp pump.

This pump is an O Series, enclosed impeller, self-priming centrifugal model with straight-in suction without a suction check valve. The pump is designed for vehicular mounting in petroleum service, and has an integral split-shaft gear box engineered for midship installation.

If there are any questions regarding the pump which are not covered in this manual or in other literature accompanying the unit, please contact your Gorman-Rupp distributor, or write:

The Gorman-Rupp Company	or	Gorman-Rupp of Canada Limited
P.O. Box 1217		70 Burwell Road
Mansfield, Ohio 44902		St. Thomas, Ontario N5P 3R7

For information or technical assistance on the power source, contact the power source manufacturer's local dealer or representative.

This is a two-part manual. Section 1 covers pump operations and maintenance, and contains pump sectional drawings and parts lists. Section 2 covers installation of the pump on a vehicle, and contains pump outline drawings and dimensions.

#### **NOTE**

Instructions to aid in installation, operation, or maintenance or which clarify a procedure.

#### **CAUTION**

Instructions which must be followed to avoid causing damage to the product or other equipment incidental to the installation. These describe the procedure required and the damage which could result from failure to follow the procedure.

#### **WARNING**

Instructions which must be followed to avoid causing injury or death to personnel. These describe the procedure required and the injury which could result from failure to follow the procedure.



## WARNINGS

Before attempting to open or service the pump:

1. Familiarize yourself with this manual.
2. Turn off vehicular ignition to ensure that the pump will remain inoperative.
3. Allow the pump to cool if overheated, and vent it slowly and cautiously.
4. Close all connecting valves and drain the pump.

This pump has been shipped dry of gearbox lubrication. The gearbox must be lubricated before the pump is operated (see LUBRICATION in Section 1).

Never run the pump dry of pumping medium. Ensure that there is a supply of liquid to the pump at all times.

Make certain that the pump is securely mounted to the truck chassis, and that connections for controls, input and output drives, and piping are secure before attempting to operate the pump.

Do not operate this pump against a closed discharge valve for long periods of time. Operating against a closed discharge valve could bring liquid to a boil, build pressure, and cause the pump to rupture.

While servicing the pump, ensure that adequate ventilation is provided, and that adequate protective clothing is worn. Service the pump in an area free from excessive heat, sparks, and flame.



Because of the nature of the liquid being pumped, overheating may produce dangerous fumes. If the pump becomes overheated, use extreme caution when venting, or when removing plates and/or plugs.

If this pump was shipped to a body builder or installer for new installation, rebuild, or retrofit, decals and tags vital to pump operation were shipped loose with the pump. Make certain that these decals and tags have been affixed in a prominent place so that they will be visible to the operator of the vehicle and/or pump operator during operation of the pump.

SECTION 1  
PUMP OPERATION, MAINTENANCE,  
AND PARTS LISTS



***Power Take Off  
Self-Priming  
Centrifugal Pump  
Model 06C15-GH1***



**WHETHER NEW INSTALLATION OR REBUILD OF FUELER,  
PLEASE READ THIS PAGE FIRST**

- 1) It is essential that tank scale dirt and any other foreign elements be removed from tank and piping prior to pump installation.
- 2) Lubrication has been removed from gearbox prior to shipment from manufacturer. Lubrication must be added before any operation.
- 3) Pump must not run dry of product at any time.



## OPERATION

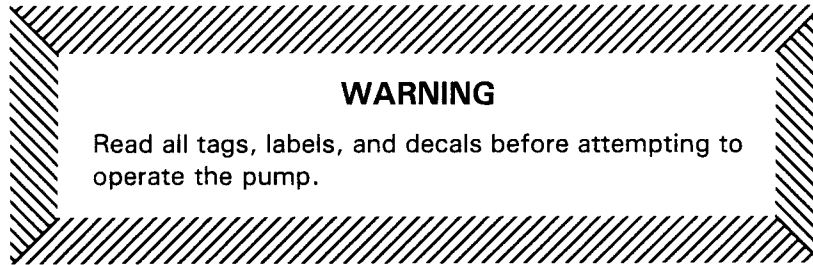

The split drive shaft design of the pump gearbox provides for selective operation of either the pump or the vehicle; both cannot be operated at the same time.

In shifting to vehicle operation, air is fed into the end cap of the air cylinder to shift the gearbox drive input shaft and clutch to engage the gearbox drive output shaft and provide direct drive to the power output shaft and rear axle of the vehicle.

In shifting to pump operation, air is fed into the shifter cover to disengage the clutch and gearbox drive output shaft, and to engage the drive input shaft to the gear train which operates the pump.

The pump air cylinder must maintain air pressure of 70 to 140 psi for air shift operation.

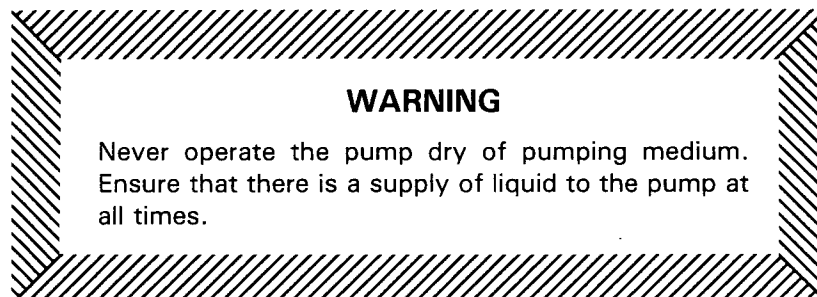
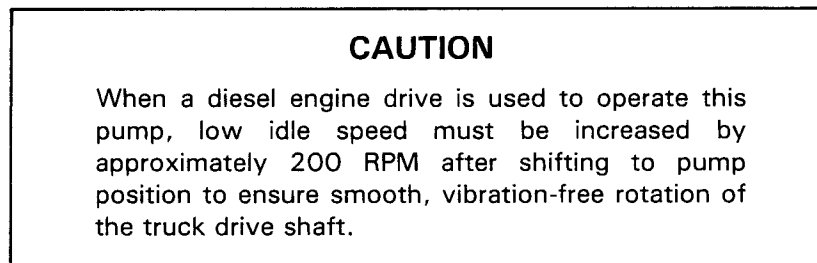

## LUBRICATION

### WARNING

This pump is shipped from the factory dry of gearbox lubrication. The gearbox must be lubricated before the pump is operated.

### NOTE

Dow Corning Molykote M Gear Guard is added to the gearbox lubricant at the factory after the pump has been tested and the gearbox has been drained. It is recommended that 4 ounces of Molykote M Gear Guard, or equivalent gear lube, be added to the gearbox at each lubrication change.

Remove the gearbox fill plug (85, figure 3), and add 5 pints — or fill until the fill plug opening overflows — of a premium quality, multi-purpose, extreme pressure gear lubricant with an SAE rating per the following ambient temperatures:

SAE No. 80	Below 40°F/4°C
SAE No. 90	From 40°F/4°C to 100°F/38°C
SAE No.140	From 100°F/38°C to 150°F/66°C

Multi-grade lubricants such as 80 W 140 are also suitable.

After an initial break-in period of 25 to 100 hours, the lubricant in a new gearbox should be changed. Drain the gearbox at operating temperatures. Remove the magnetic drain plug (44, figure 3), drain the gearbox, and thoroughly clean the gearbox with draining oil after flushing. The lubricant should be changed more frequently when the pump is operating under severe conditions, such as in heavily dusty atmospheres or rapid temperature change areas. Always clean the magnetic drain plug before reinstalling it.

Check the oil in the gearbox monthly, and maintain it at the proper level. A monthly check of the gearbox for leaks is also recommended.

The seal assembly is lubricated by the medium being pumped, and no further lubrication of the seal is necessary.

## MAINTENANCE AND REPAIR

### WARNING

Before attempting to service the pump:

1. Familiarize yourself with this manual.
2. Turn off vehicular ignition to ensure that the pump will be inoperative.
3. Allow the pump to cool if overheated, and vent it slowly and cautiously.
4. Close all connecting valves, and drain the pump.

The position of the pump unit below the tank and between the principal frame members of the vehicle chassis provides maximum accessibility to the impeller, wear rings, and seal assembly, the pump parts susceptible to greatest wear. These parts may be serviced with the pump in place on the truck chassis.

If it is necessary to service the gearbox, it is recommended that the entire pump unit be removed from the chassis.

This pump requires little service due to its rugged, minimum-maintenance design. If it becomes necessary to inspect or replace components, however, follow these instructions, which are keyed to the sectional views (see figures 1 and 3) and the accompanying parts lists.

### Pump End Only Disassembly

### WARNING

When servicing the pump, ensure that adequate ventilation is provided, and that adequate protective clothing is worn. Service the pump in an area free from sparks, flame, and excessive heat.

The instructions in this section are keyed to figure 1 and the accompanying parts list.

# SECTIONAL DRAWING

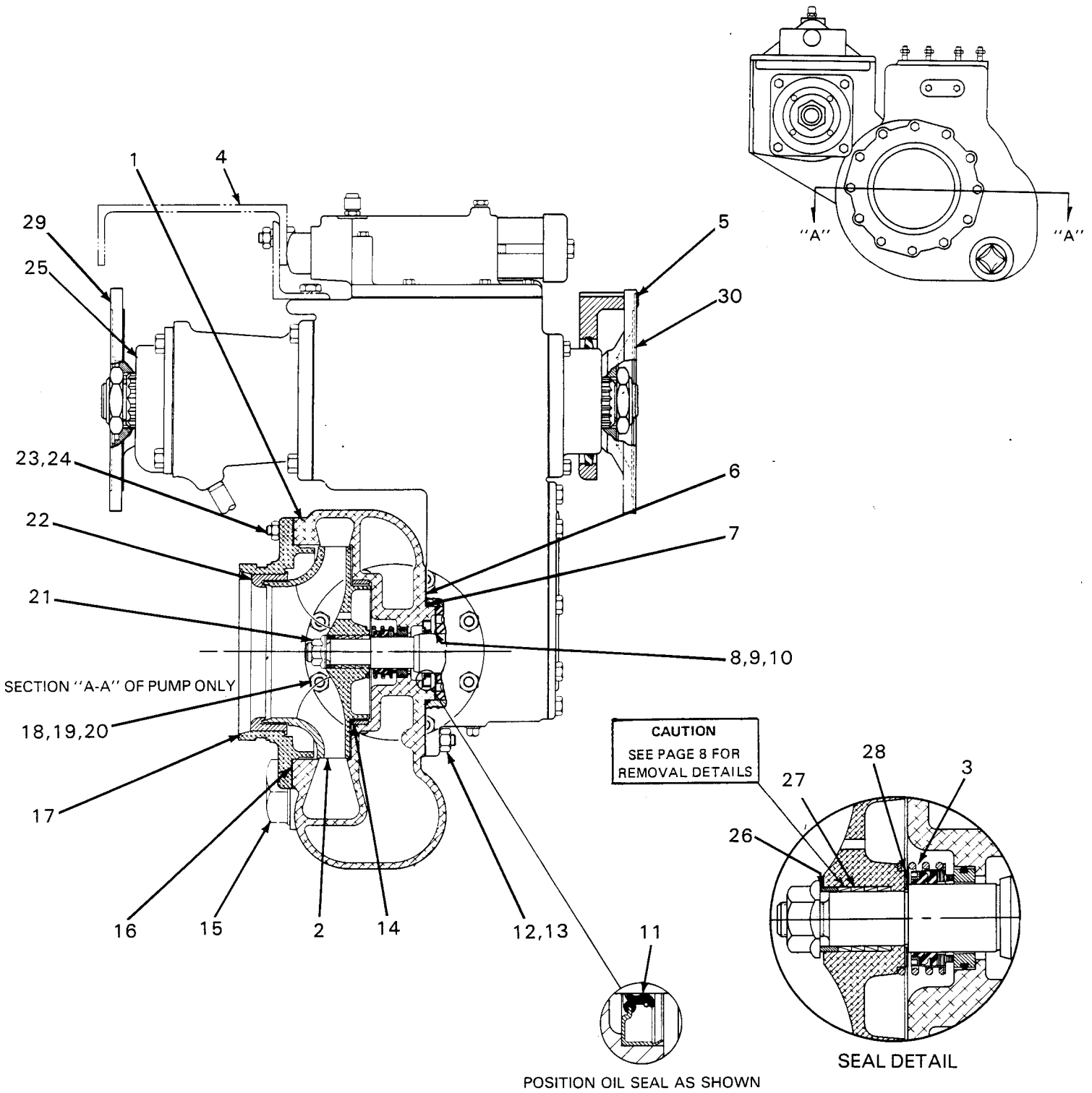

Figure 1. Pump Model 06C15-GH1



**PARTS LIST**  
**PUMP MODEL 06C15-GH1**  
(From S/N 699997 up)

CANADIAN SERIAL NO. . . . . AND UP

ITEM NO.	PART NAME	PART NUMBER	MATL CODE	QTY
1	VOLUTE HOUSING	8377	13040	1
2	★ IMPELLER	38624-507	—	1
3	★ SEAL ASSEMBLY	25271-192	—	1
4	CROSS MEMBER	8891	—	1
5	TRUNNION ASSEMBLY	8767	11000	1
6	★ VOLUTE HOUSING GASKET	8377-G	18000	1
7	★ VOLUTE HOUSING O-RING	S-2085	—	1
8	★ BEARING SHIM SET	8543	15990	1
9	BEARING SHIM	NOT AVAILABLE		1
10	BEARING SHIM	NOT AVAILABLE		1
11	★ OIL SEAL	S-2007	—	1
12	STUD	C-0807	15991	6
13	HEX NUT	D-08	15991	6
14	★ VOLUTE HOUSING WEAR RING	8464	10018	1
15	VOLUTE DRAIN PLUG	P-32	11991	1
16	★ SUCTION HEAD GASKET	8376-G	20000	1
17	SUCTION HEAD	10218	13040	1
18	★ DISCHARGE FLANGE GASKET	5372-G	20000	1
19	STUD	C-0605½	15991	8
20	HEX NUT	D-06	15991	8
21	IMPELLER LOCKNUT	S-2202	—	1
22	SUCTION HEAD WEAR RING	64H5	10018	1
23	STUD	C-0606	15991	12
24	HEX NUT	D-06	15991	12
25	GEARBOX ASSEMBLY (See figure 3)	14017	—	1
26	IMPELLER SPACER	31143-059	—	1
27	LOCKING ELEMENTS	24133-025	—	4
28	IMPELLER SHIM SET	2-X	17090	1
29	OUTPUT COMPANION FLANGE	S-2272-A	—	1
30	INPUT COMPANION FLANGE	S-2271	—	1
NOT SHOWN:				
	NAME PLATE	2613-AY	13990	1
	DRIVE SCREW	BM#04-03	15990	4
	PUMP MOUNTING HARDWARE			
	CAPSCREW	9016	15990	2
	HEX HEAD CAPSCREW	B-0804	15991	2
	HEX HEAD CAPSCREW	B-0805	15991	2
	HEX HEAD CAPSCREW	B-1004	15991	4
	HEX NUT	D-08	15991	2
	HEX NUT	D-10	15991	2
	LOCKWASHER	J-08	15991	4
	LOCKWASHER	J-10	15991	4
OPTIONAL:				
	MECHANICS FLANGE KIT	48123-004	—	1
	AIR SHIFTER KIT	S-2275	—	1
	AUXILIARY STUB SHAFT ASSY	48123-005	—	1
	PARTS KIT FOR 90° GEAR BOX ROTATION	48123-003	—	1

★ INDICATES PARTS RECOMMENDED FOR STOCK

Close all connecting valves and remove the volute drain plug (15) to drain the pump. Clean and reinstall the drain plug.

Remove a section of suction piping at the suction head (17). Remove the hex nuts (24) securing the suction head to the volute housing (1), and remove the suction head. The impeller (2) is now accessible.

Before removing the impeller, drain the gearbox (25), by removing the magnetic drain plug (44, figure 3). Clean and reinstall the drain plug after draining the gearbox.

To remove the impeller, remove the impeller locknut (21) and spacer (26). The locking elements (27) should separate when the locknut and spacer are removed. If the elements jam, loosen them by tapping the end of the shaft lightly with a soft-faced mallet or hammer; use caution not to damage the shaft threads. A stiff wire with a hooked end may be useful in removing the locking elements.

Remove the impeller and the impeller adjusting shims (28). For ease of reassembly, tag and tie the shims, or measure and record their thickness.

The shaft seal assembly (3) is now accessible. This seal prevents air and liquid in the volute from escaping along the impeller shaft. A steady drip of product in the seal area indicates that the seal has failed and should be replaced.

Remove the seal spring. Using a stiff wire with a hooked end if necessary, remove the balance of the seal components.

Clean the shaft, impeller hub bore, impeller spacer, and locking elements with a soft cloth soaked in solvent.

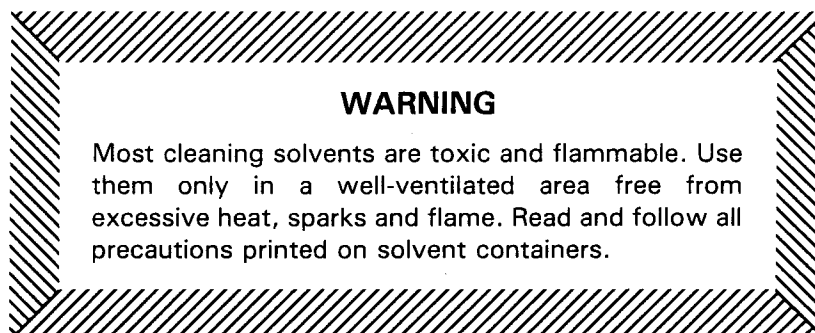

The presence of gearbox lubricant in the area of the seal cavity may indicate failure of the gearbox oil seal (11). Disconnect the discharge piping at the pump discharge flange, and remove the hex nuts (13) securing the volute housing to the gearbox.

### Pump End Only Reassembly

Replace the gearbox oil seal if defective, and inspect the volute housing wear ring (14), which is a press fit in the volute housing. Replace the wear ring if scored or worn, taking care not to damage the new wear ring or the volute housing.

Replace the volute housing gasket (6) and O-ring (7), and reinstall the volute housing on the gearbox. Replace the discharge flange gasket (18), and reinstall the discharge piping.

The seal is not normally reused because of the high polish on its lapped faces, but if it is necessary to reuse the old seal, wash all metallic parts in cleaning solvent and dry thoroughly.

Inspect the seal components for wear, scoring, grooves, and other damage that might cause leakage. If any components are worn, replace the complete seal; never mix old and new seal parts.

#### **CAUTION**

This seal is not designed for operation at temperatures above 160°F. Do not use at higher operating temperatures.

See figure 2 for the correct order of installation of seal components.

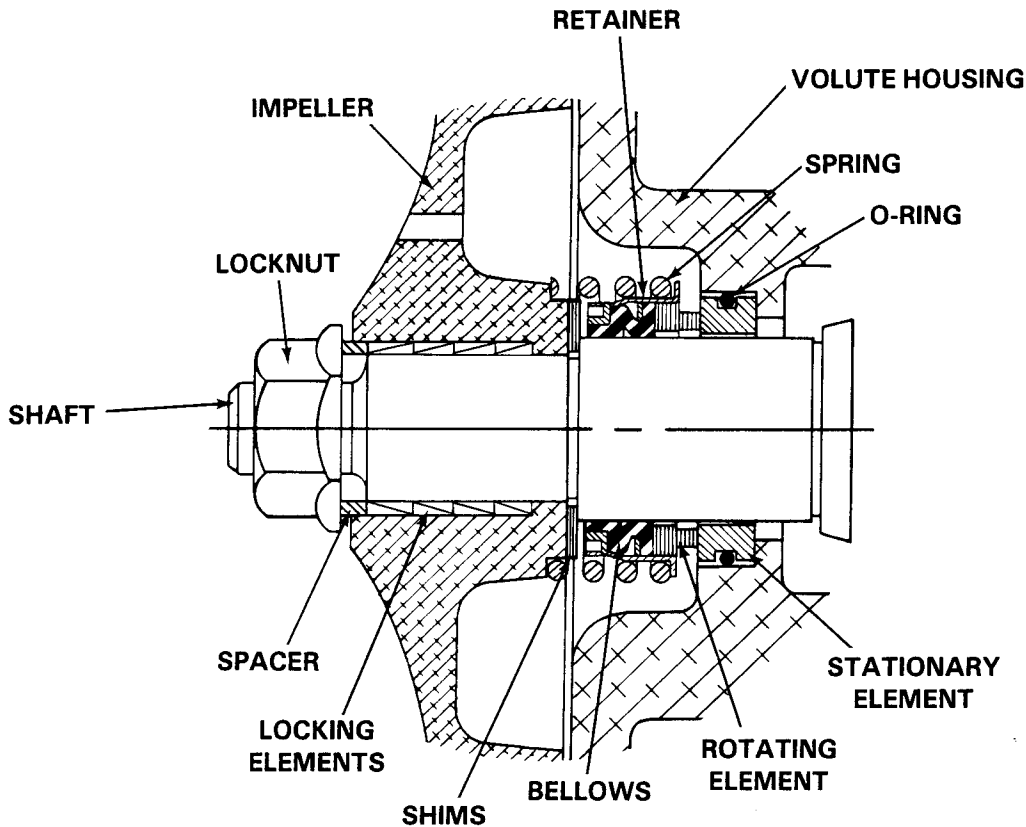

Figure 2. 25271-192 Seal Assembly

Place a drop of light lubricating oil on the lapped faces of the seal. Install a stationary seat, stationary element, and rotating element. Lubricate the bellows with soft grease or oil, and install the bellows assembly. Install the seal spring, making certain that all components of the seal are seated squarely.

Install the impeller adjusting shims. For maximum pump efficiency, the impeller must be centered in the volute scroll. If the same number and thickness of impeller adjusting shims are reinstalled as were removed, the impeller should be correctly centered.

Inspect the impeller, and replace it if cracked or badly worn. Lightly oil the shaft, impeller hub bore, spacer, and locking elements. (Do not use a lubricant containing molybdenum disulphide.) Position the impeller on the shaft.

The impeller locking elements must be installed in inner-ring, outer-ring sequence. It is recommended that a special tool (not furnished by Gorman-Rupp) be used when installing the locking elements; see figure 2a. This tool can be made from 1 1/4-inch O.D. by 7/8-inch I.D. round mechanical tubing.



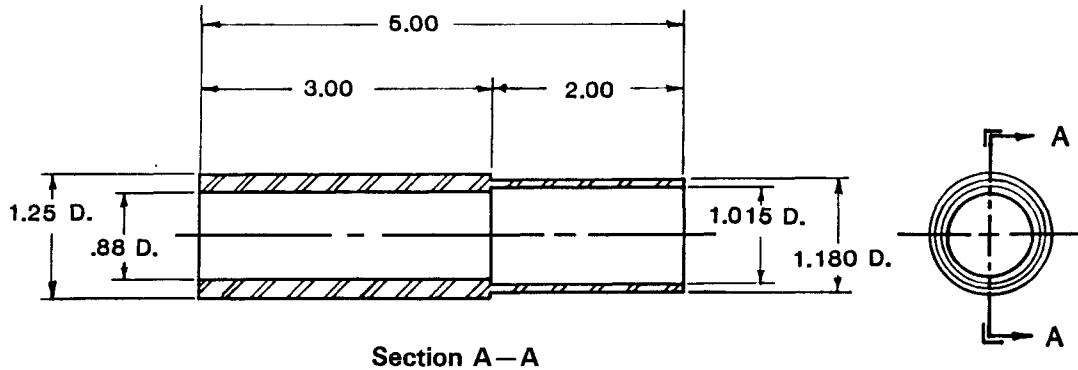

**Figure 2a. Locking Element Installation Tool**

Using the tool, install the first locking element in inner-ring, outer-ring sequence in the bore of the impeller so that it seats squarely against the impeller shoulder. Install the next and subsequent locking elements so that they seat squarely against the previously installed element.

Install the impeller spacer and lock nut, and torque the lock nut to 120 ft. lbs.

Inspect the suction head wear ring (22) which is a press fit in the suction head. Replace the wear ring if scored or worn, taking care not to damage the new wear ring or the suction head.

Replace the suction head gasket (16), reinstall the suction head, and reinstall the suction piping.

Fill the gearbox with lubricant (see LUBRICATION, page 4). Make certain that all piping connections to the pump are secure. Open all connecting valves and make certain that there is a supply of liquid to the pump before starting the pump.

#### **Gearbox Disassembly**

The instructions in this section are keyed to figure 3 and the accompanying parts list.

# SECTIONAL DRAWING

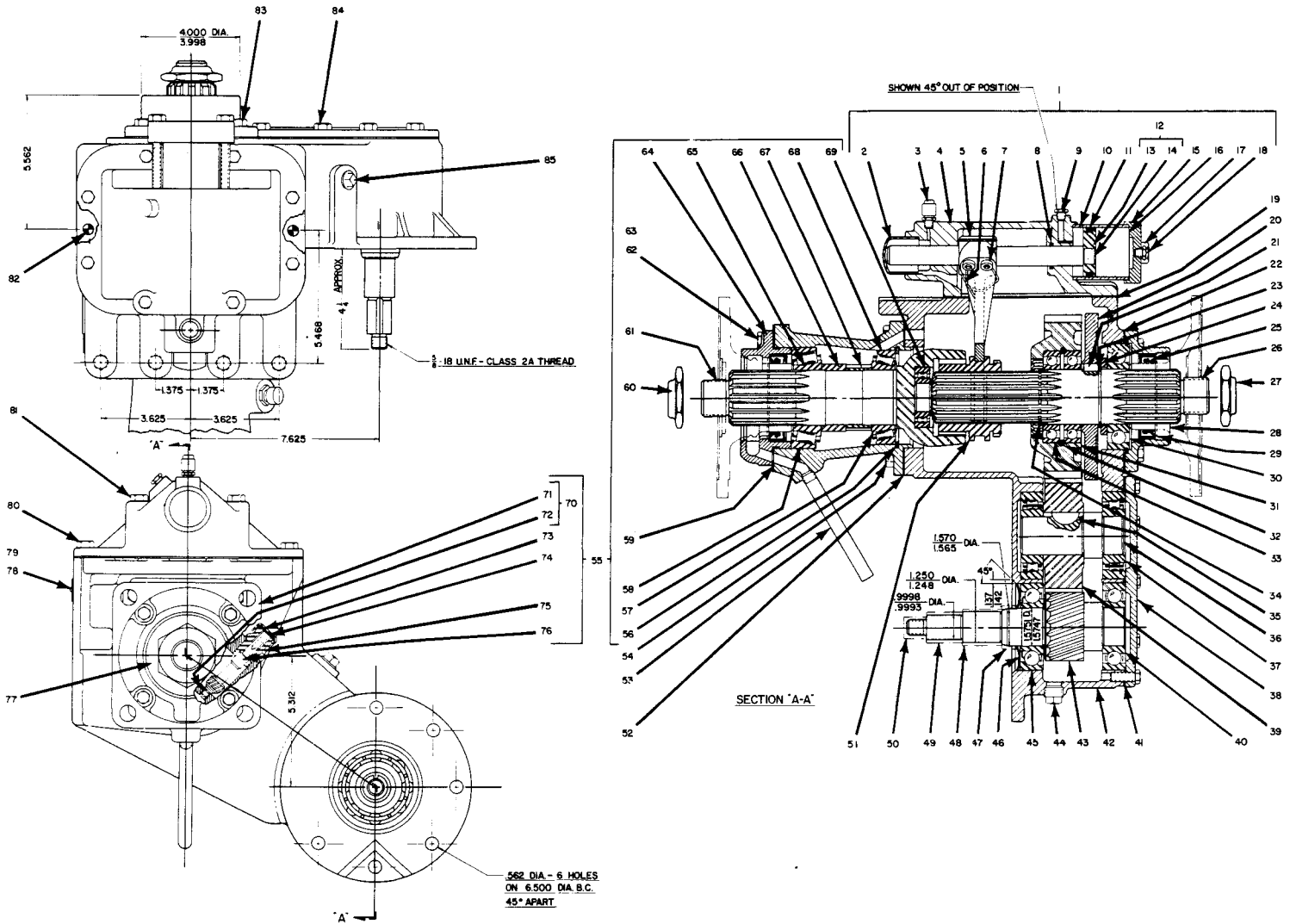

Figure 3. P/N 14017 Gear Box Assembly For Pump Model 06C15-GH1



## PARTS LIST

### P/N 14017 GEARBOX ASSEMBLY FOR PUMP MODEL 06C15-GH1

ITEM NO.	PART NAME	PART NUMBER	QTY	ITEM NO.	PART NAME	PART NUMBER	QTY
1	AIR SHIFT COVER ASSY, INCL:	24571-201	1	47	SHIPPING COVER	—	1
2	HOUSING PLUG	24571-176	1	48	SHIPPING COVER	—	1
3	PRESSURE RELIEF FITTING	S-1530	1	49	SHIPPING COVER	—	1
4	SHIFTER COVER	24571-202	1	50	SHIPPING COVER	—	1
5	SHIFTER FORK	24571-213	1	51	SLIDING CLUTCH	24571-077	1
6	SAFETY WIRE	24571-165	1	52	BRAKE BRACKET GASKET	24571-110	1
7	SOCKET HEAD CAPSCREW	24571-182	2	53	OUTPUT BEARING CAP VENT	24571-051	1
8	SHAFT O-RING	24571-214	1	54	HEX HEAD CAPSCREW	24571-111	4
9	PLASTIC SHIPPING PLUG	24571-174	1	55	TAIL SHAFT ASSEMBLY, INCL:	24571-102	1
10	CYLINDER	24571-221	1	56	BEARING RETAINING RING	24571-143	1
11	PISTON O-RING	24571-215	1	57	TAPERED BEARING CONE	23765-426	1
12	SHAFT/PISTON ASSY, INCL:	24571-210	1	58	TAPERED BEARING CUP	23775-028	1
13	PISTON	—	1	59	OUTPUT BEARING CAP SHIMS	24571-117	2
14	SHIFTER SHAFT	—	1			24571-118	
15	CYLINDER CAP	24571-222	1	60	OUTPUT DRIVE FLNG LOCKNUT	22568-137	1
16	GASKET	24571-203	2	61	OUTPUT DRIVE SHAFT	24571-132	1
17	HEX HEAD CAPSCREW	24571-223	2	62	HEX HEAD CAPSCREW	24571-041	4
18	PLASTIC SHIPPING PLUG	24571-174	1	63	HY-COLLER LOCKWASHER	21171-903	4
19	SHIFTER COVER GASKET	24571-036	1	64	OUTPUT BEARING CAP	24571-116	1
20	LUBE GEAR	24571-075	1	65	TAPERED BEARING CONE	23765-425	1
21	LUBE GEAR KEY	N-0302½	1	66	SPACER	24571-134	1
22	INPUT BEARING CAP GASKETS	24571-047	1	67	SPEEDO GEAR	24571-152	1
		24571-048	1	68	TAPERED BEARING CUP	23775-331	1
23	LUBE GEAR RETAINING RING	24571-087	1	69	ROLLER BEARING	23528-002	1
24	SPACER	24571-067	1	70	BRAKE BRACKET ASSY, INCL:	24571-106	1
25	SHIPPING COVER	—	1	71	BRAKE BRACKET	24571-108	1
26	INPUT DRIVE SHAFT	24571-061	1	72	BUSHING	24571-109	1
27	INPUT DRIVE FLANGE LOCKNUT	22568-137	1	73	DUST CAP	24571-155	1
28	INPUT BEARING CAP	24571-046	1	74	DUST CAP GASKET	24571-156	1
29	OIL SEAL	24571-092	1	75	SLEEVE NUT	24571-154	1
30	BALL BEARING	23263-017	1	76	SPEEDO GEAR	24571-153	1
31	DRIVE GEAR	24571-072	1	77	SHIPPING COVER	—	1
32	BEARING RETAINING RING	24571-088	1	78	NAME PLATE	—	1
33	BALL BEARING	23231-513	2	79	DRIVE SCREW	—	2
34	RETAINING RING	24571-085	1	80	HEX HEAD CAPSCREW	24571-037	6
35	IDLER SHAFT KEY	AV-1009	1	81	HEX HEAD CAPSCREW	24571-204	2
36	IDLER SHAFT	24571-062	1	82	DOWEL PIN	AA-0704	2
37	ROLLER BEARING	24571-081	2	83	HEX HEAD CAPSCREW	24571-049	4
38	BEARING COVER	24571-039	1	84	HEX HEAD CAPSCREW	24571-041	8
39	IDLER GEAR	24571-073	1	85	GEARBOX FILL PLUG	P-08	1
40	BALL BEARING	S-1080	1		NOT SHOWN:		
41	BEARING COVER GASKET	24571-040	1		SHAFT EXTENSION	14196	1
42	GEARBOX HOUSING	24571-030	1		SHAFT KEY	N-0404	1
43	IMPELLER SHAFT	10202-B	1		OIL SEAL	S-2276	1
44	GEARBOX DRAIN PLUG	PM-08	1		DOWEL PIN	AA-0403	2
45	BALL BEARING	23413-209	1		AIR SHIFTER KIT	S-2275	1
46	SHIPPING COVER	—	1				



### **Removing Pump Unit**

Close all connecting piping valves, drain the pump, and disconnect the suction and discharge piping (see Pump End Only Disassembly).

Remove the drain plug (44) to drain the gearbox. Clean and reinstall the drain plug.

Shut off air supply to the lines connecting to the air shift cover assembly, or bleed the pump air cylinder. Disconnect the air lines at the air shift cover.

Disconnect the input and output companion drive flanges at their respective universal joints.

Remove the hardware securing the trunnion bracket to the front cross member, and the hardware securing the pump and gearbox mounting flanges to the rear cross member. Remove the pump from the vehicle chassis.

### **Air Shift Cover Disassembly**

To remove the air shift cover assembly (1), disengage the hex head capscrews (80 and 81) securing the assembly to the gearbox housing (42), and remove the assembly.

Disengage the hex head capscrews (17) and remove the cylinder cap (15) and cylinder (10). Inspect the piston (13), shifter shaft (14), and shifter fork (5) for wear, and replace as necessary. To remove the shifter fork from the shaft, disengage the safety-wired socket head capscrews (7).

### **Split Shaft Disassembly**

Disengage the lock nuts (27 and 60) securing the input and output companion drive flanges to their respective shafts, and remove the flanges.

### **NOTE**

After the flanges have been removed, reinstall the lock nuts to protect the shafts' threads.

To remove the tail shaft assembly (55) — which includes the output drive shaft (61) — disengage the hex head capscrews (54) securing the assembly to the gearbox housing.

Remove the hex head capscrews (62) securing the output bearing cap (64) to the brake bracket assembly (70). Remove and inspect the oil seal, and replace it if necessary. Be sure to retain the output bearing cap shims (59).

If the output drive shaft is to be removed from the tail assembly, first remove the speedo gear (76) by disengaging the sleeve nut (75).

To remove the input drive shaft (26), remove the hardware securing the input bearing cap (28) to the gearbox housing. Remove and inspect the oil seal (29), and replace it if necessary. Remove the ball bearing (30), spacer (24), and lube gear retaining ring (23).

Remove the sliding clutch (51). Pull out the input drive shaft, and reach in through the top of the gearbox to remove the drive gear and retaining ring (31 and 34), bearings and bearing retaining ring (33 and 32), and lube gear and lube gear key (20 and 21), as they are disengaged from the input drive shaft.

### **Idler Shaft Disassembly**

Disengage the hardware securing the bearing cover (38) to the gearbox housing, and remove the cover. Remove the front roller bearing (37). There is a  $\frac{3}{4}$ -10NC USS tapped hole at the end of the idler shaft (36) to accommodate a puller. Pull the shaft and shaft key (35) through the idler gear (39). Remove the idler gear through the top of the gearbox. Remove the rear roller bearing from the gearbox cavity.

### **Impeller Shaft Disassembly**

With the pump end only disassembled (see Pump End Only Disassembly), the impeller shaft (43) and bearings (40 and 45) can be tapped out from either side of the gearbox.

### **Gearbox Reassembly**

Inspect all parts for wear, and replace as necessary.

When reassembling the gearbox, replace all gaskets and O-rings.

### **Impeller Shaft Reassembly**

If the rear ball bearing (45) on the impeller shaft has been replaced, or if it has been removed, reinstall the bearing so that the printing on the outer race faces away from the impeller shaft gear, and the printing on the inner races faces toward the gear.

Reinstall the impeller shaft and bearings in the gearbox. Align the front ball bearing (40) in the gearbox cavity.

### **Idler Shaft Reassembly**

Install the rear roller bearing in the bearing cavity so that the shoulder of the inner race faces the idler gear. Install the idler shaft key, position the idler gear in the gearbox cavity, and install the idler shaft. Make certain that the idler gear is engaged by the key and snug against the rear roller bearing.

Install the front roller bearing so that the shoulder of the inner race faces the idler gear and is snug against the shoulder of the shaft.

Replace the bearing cover gasket (41), and secure the bearing cover to the gearbox housing.

### **Split Shaft Reassembly**

To reinstall the input drive shaft, position the lube gear in the gearbox cavity and slide the drive shaft through it.

Install the drive gear retaining ring, and the bearings and retaining ring, in the drive gear, making certain that the bearings retaining ring seats in the groove in the drive shaft cavity. Position the drive gear assembly in the gearbox, and engage the assembly on the splined end of the shaft.

Install the lube gear retaining ring, and the lube gear shaft key. Slide the lube gear forward until it is engaged by the shaft key and flush against the retaining ring.

Install the spacer and the ball bearing. Lubricate the lip of the oil seal, and install the oil seal in the input bearing cavity so that the lip of the seal is positioned as shown in figure 3. Replace the input bearing cap gaskets (22), and secure the bearing cap to the gearbox housing.



Move the drive gear assembly forward until the front bearing is flush against the lube gear, and the drive gear retaining ring seats in the groove on the shaft.

Install the sliding clutch on the splined end of the shaft.

If the output drive shaft has been removed from the tail shaft assembly, reinstall the shaft and the speedo gear.

To reinstall the tail shaft assembly, lubricate the lip of the oil seal, and install the oil seal in the output bearing cavity so that the lip of the seal is positioned as shown in figure 3. Reinstall the output bearing cap shims, and secure the bearing cap to the tail shaft assembly. Be sure that the two sections of the bearing cap vent are aligned and the bearing cap shims (59), making certain that it does not block the bearing cap vent passage.

Replace the brake bracket gasket (52), and secure the tail shaft assembly to the gearbox housing. Disengage the sliding clutch from the output drive shaft, and turn the shaft by hand; there should be no drag or play in the tail assembly bearings. Add or subtract bearing cap shims to make any necessary adjustments.

Position the input and output companion drive flanges on their respective shafts.

To minimize fretting corrosion, the flanges are designed for a tight fit on the drive shafts, and slight interference may be encountered. As an aid to driving and seating the flanges on the shafts, a heavy-duty sleeve is recommended. The sleeve should have an approximate outside diameter of 2-7/8 inches and an inside diameter of 2-1/4 inches in order to clear the drive shafts and fit the counterbore of the drive flanges. After the flanges are firmly and squarely seated on the drive shafts, secure them with the locknuts, and torque the locknuts to 500 ft. lbs.

#### **Air Shift Cover Reassembly**

Replace the air shifter shaft O-ring (8), lubricating it thoroughly with Parker O-Lube before installation.

Position the air shifter fork in the air shaft cover cavity, and install the air shifter shaft. Secure the shifter shaft to the fork with socket head capscrews torqued to 40-45 ft. lbs. Reinstall the safety wire thru the hex head capscrews after tightening them.

Replace the piston O-ring (11), lubricating it thoroughly with Parker O-Lube before installation. Lubricate the piston thoroughly with Parker O-Lube, position the cylinder and cylinder cap, and secure to the air shift cover. Tighten the capscrews evenly to prevent cocking the cylinder body, and torque the screws to 33-37 ft. lbs. Check to ensure that the shifter shaft slides freely.

Check the air cylinder with test pressures to 120-150 psi to ensure that there are no air leaks.

Engage the air shifter fork with the sliding clutch, and secure the air shift cover assembly to the gearbox housing.

If the pump end only was removed, reinstall it (see Pump End Only Reassembly).

### Reinstalling Pump Unit

Secure the trunnion bracket, and the pump and gearbox mounting flanges, to the front and rear cross members respectively. Position the mounted pump on the vehicle chassis side rails.

For installation of pump piping and air lines, and installation and alignment of universal joints and power drive shafts, see Section 2.

### LUBRICATION

See LUBRICATION, Section 1, for gearbox lubrication.



#### WARNING

Do not attempt to operate the pump unless the gearbox has been properly lubricated.



#### WARNING

Open all connecting valves before attempting to operate the pump. Never operate the pump unless there is a supply of liquid to the pump.



**\* STANDARD PERFORMANCE FOR PUMP MODEL 06C15-GH1**

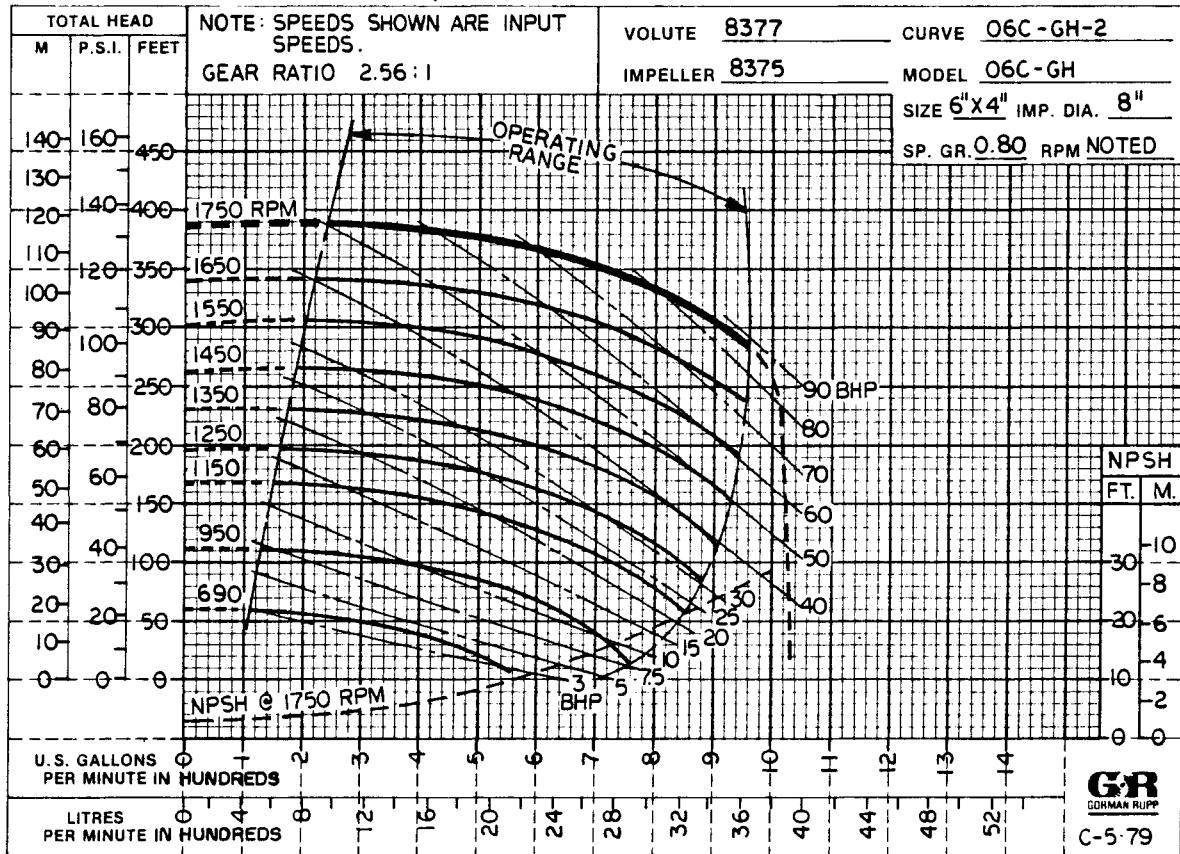

\* Based on 70° clear water at sea level corrected to 0.80 specific gravity with minimum suction lift. Since pump installations are seldom identical, your performance may be different due to such factors as viscosity, specific gravity, elevation, temperature, and impeller trim.

If your pump serial number is followed by an "N", or if you have any question on performance, contact The Gorman-Rupp Company.



SECTION 2  
PUMP INSTALLATION

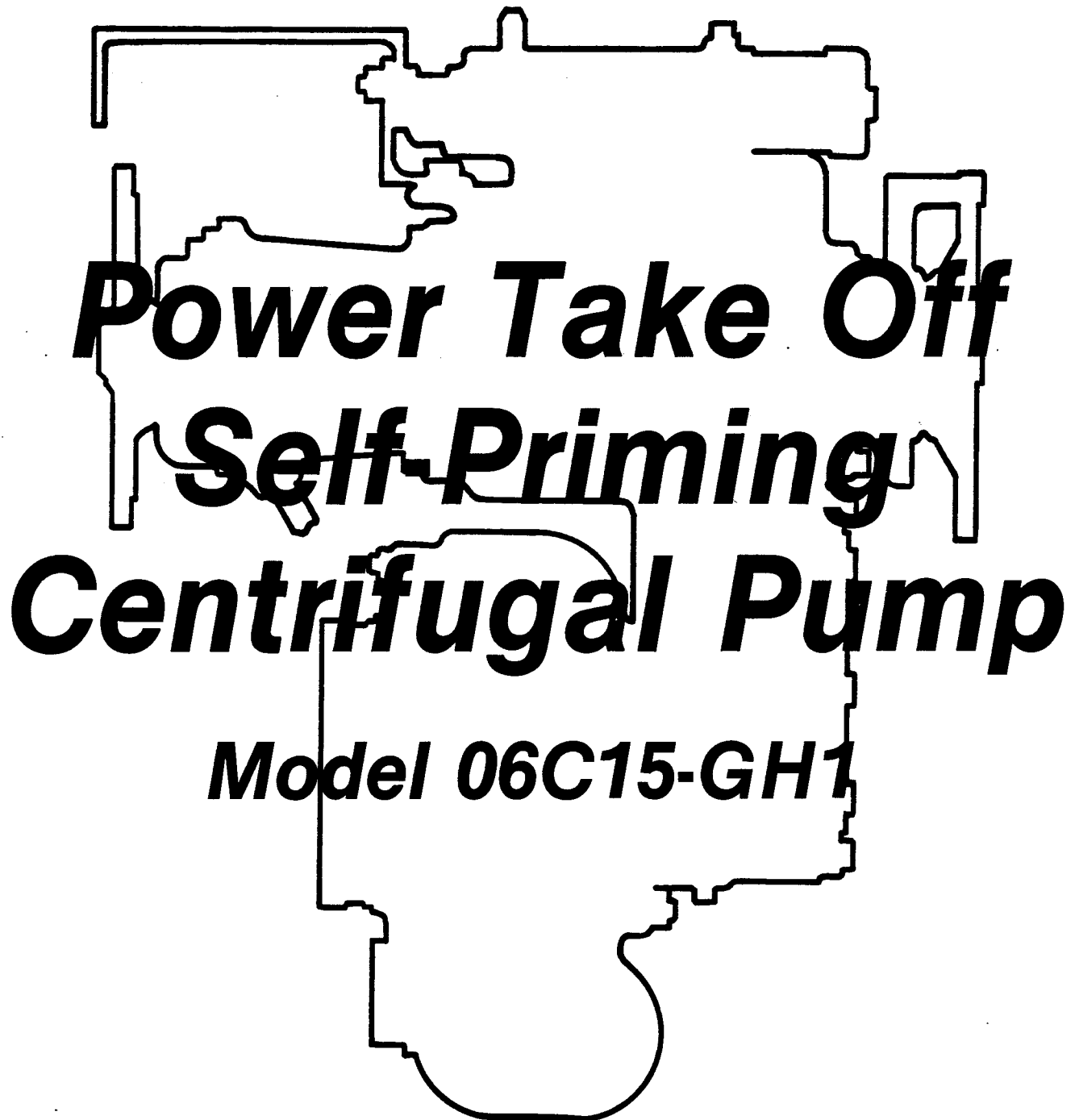



Section 2 covers recommended pump installation on fueling vehicles, and applies equally to new installations, rebuilds, and retrofits.

**CAUTION**

Decals and tags vital to proper pump operation are shipped separately with the pump. The body builder or pump installer should affix these decals and tags in a prominent place — vehicle cab, pumping control panel, etc. — so that they will be visible to the vehicle operator and/or pump operator during pumping operations.

Tank scale, dirt, and any other foreign material must be removed from the fuel tank and piping prior to pump installation; the pump may be damaged otherwise.

**WARNING**

After installation, do not attempt to test run or operate this pump and integral gearbox before reading OPERATION in Section 1. This pump was shipped dry of gearbox lubrication. See LUBRICATION, Section 1, before attempting to operate the pump.

If this pump is to be used in tractor trailer or truck plus trailer service, either a liquid fifth wheel or jumper hoses are required.

**CAUTION**

In tractor trailer or truck plus trailer service, the driveline must be long enough to allow installation of the gearbox at the proper angle, and jumper hoses must be long enough for full turning radius.

**TYPICAL INSTALLATION USING EDUCTOR FOR DEFUELING AND FUELING**

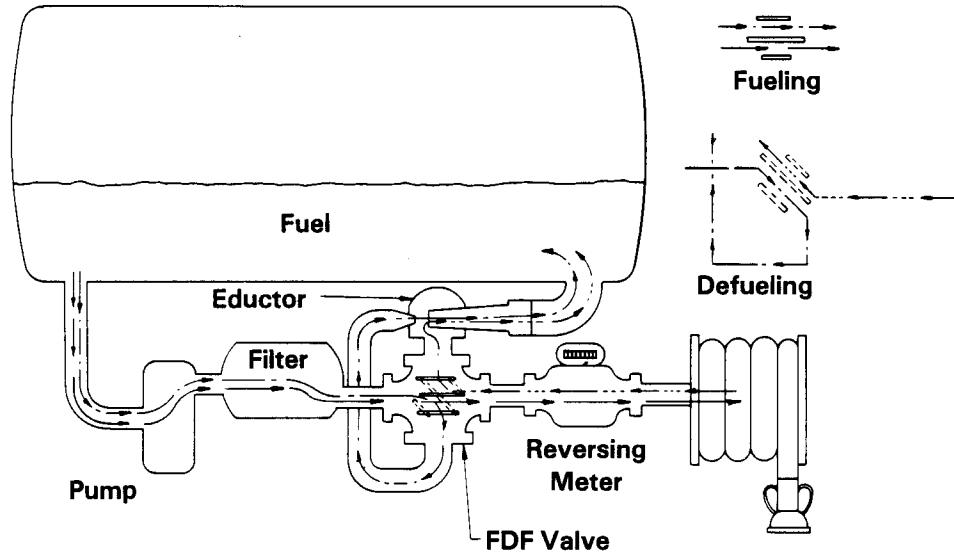

**TYPICAL INSTALLATION USING PUMP FOR DEFUELING AND FUELING**

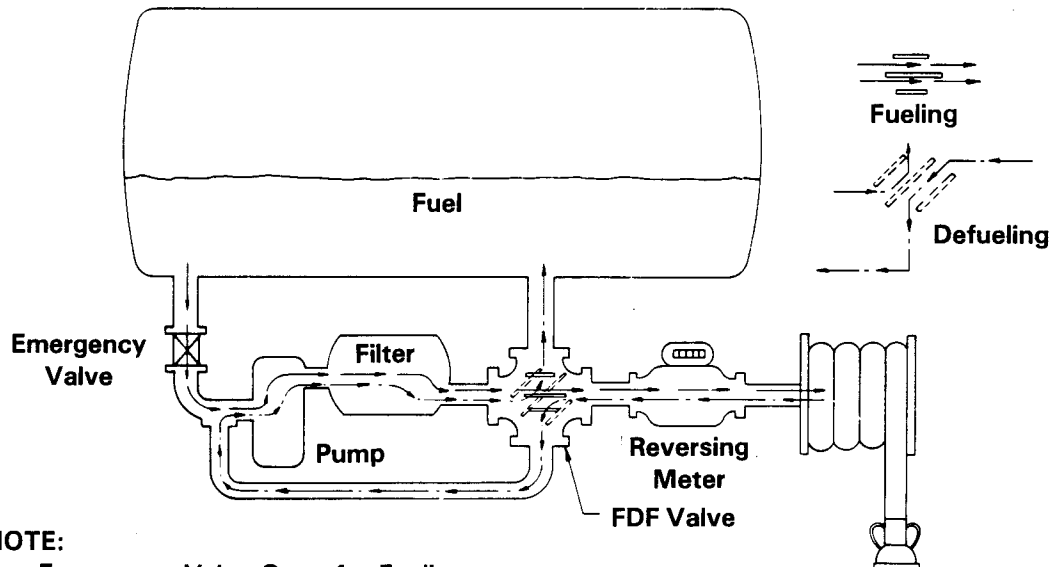

**NOTE:**  
Emergency Valve Open for Fueling.  
Emergency Valve Closed for Defueling.

**Figure 1. Typical Pumping Systems for Fueling Vehicles**

### Pump and Gearbox Mounting

Consideration should be given to the configuration of pump piping, and to air shift connections, when mounting the pump and integral gearbox. See figure 2 for dimensions of this pump.

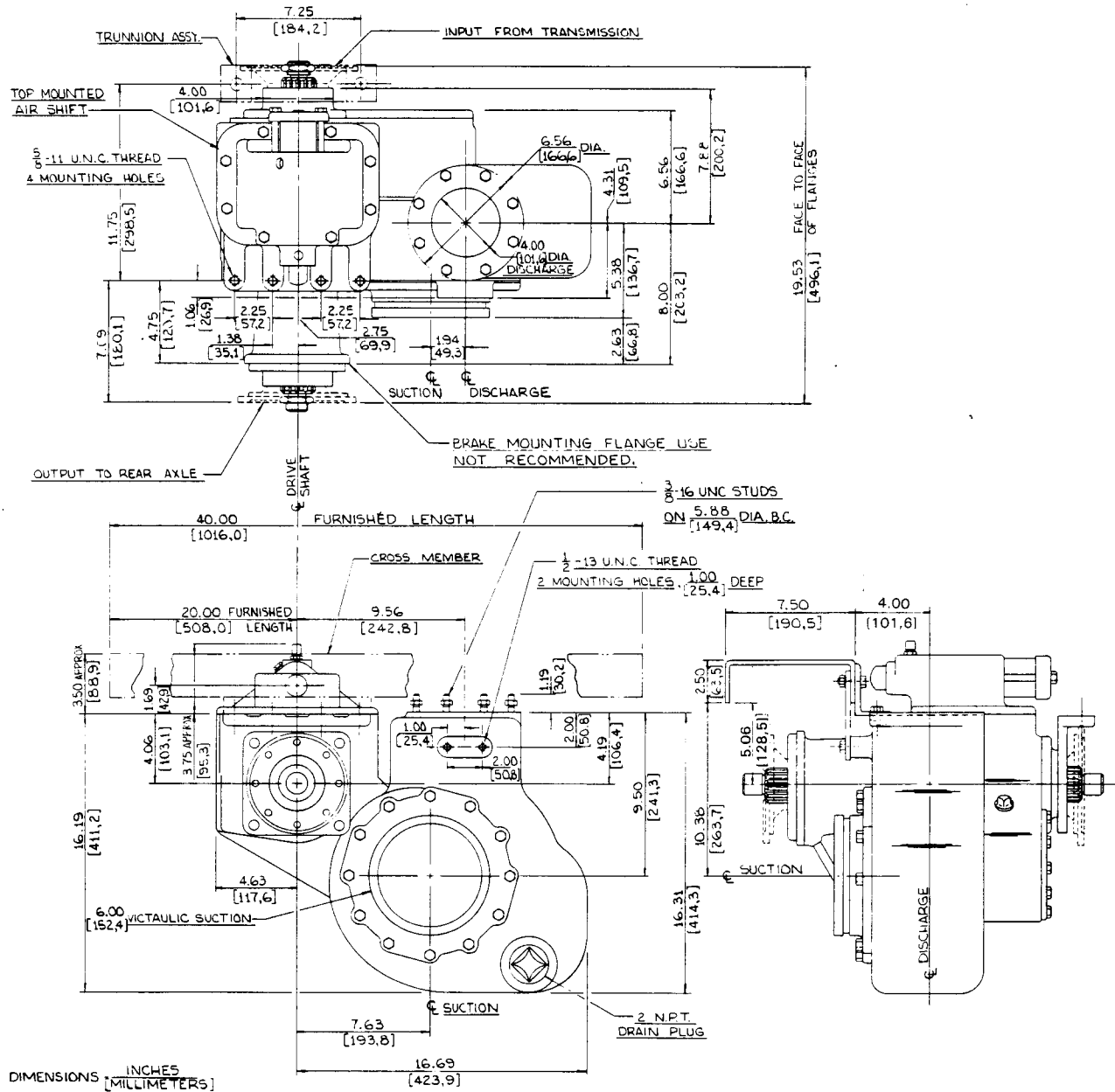

Figure 2. Dimensions of Pump Model 06C15-GH1

A rear cross member 40 inches long is shipped with the pump, and can be cut to size to fit the side rails of the vehicle chassis. Using hardware provided with the pump, rigidly mount the flanges on the pump and gearbox to the rear cross member (see figure 3).

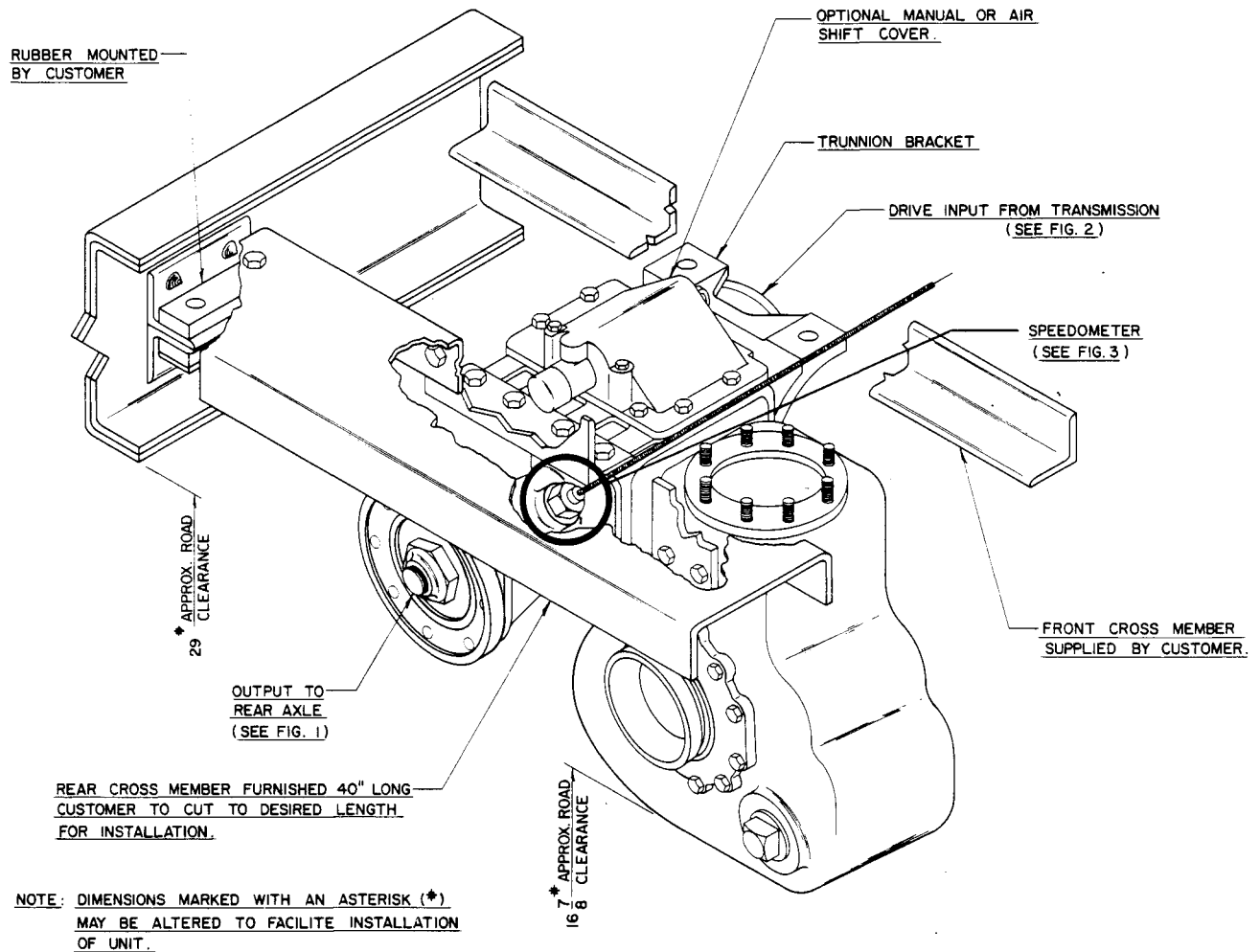

Figure 3. Typical Pump Mounting on Vehicle Chassis

The speedometer adapter for units with speedometer drive is for truck speed and mileage only. The adapter has a 3/16-inch SAE drive, and operates at a 4.66:1 decrease ratio (see figure 4).

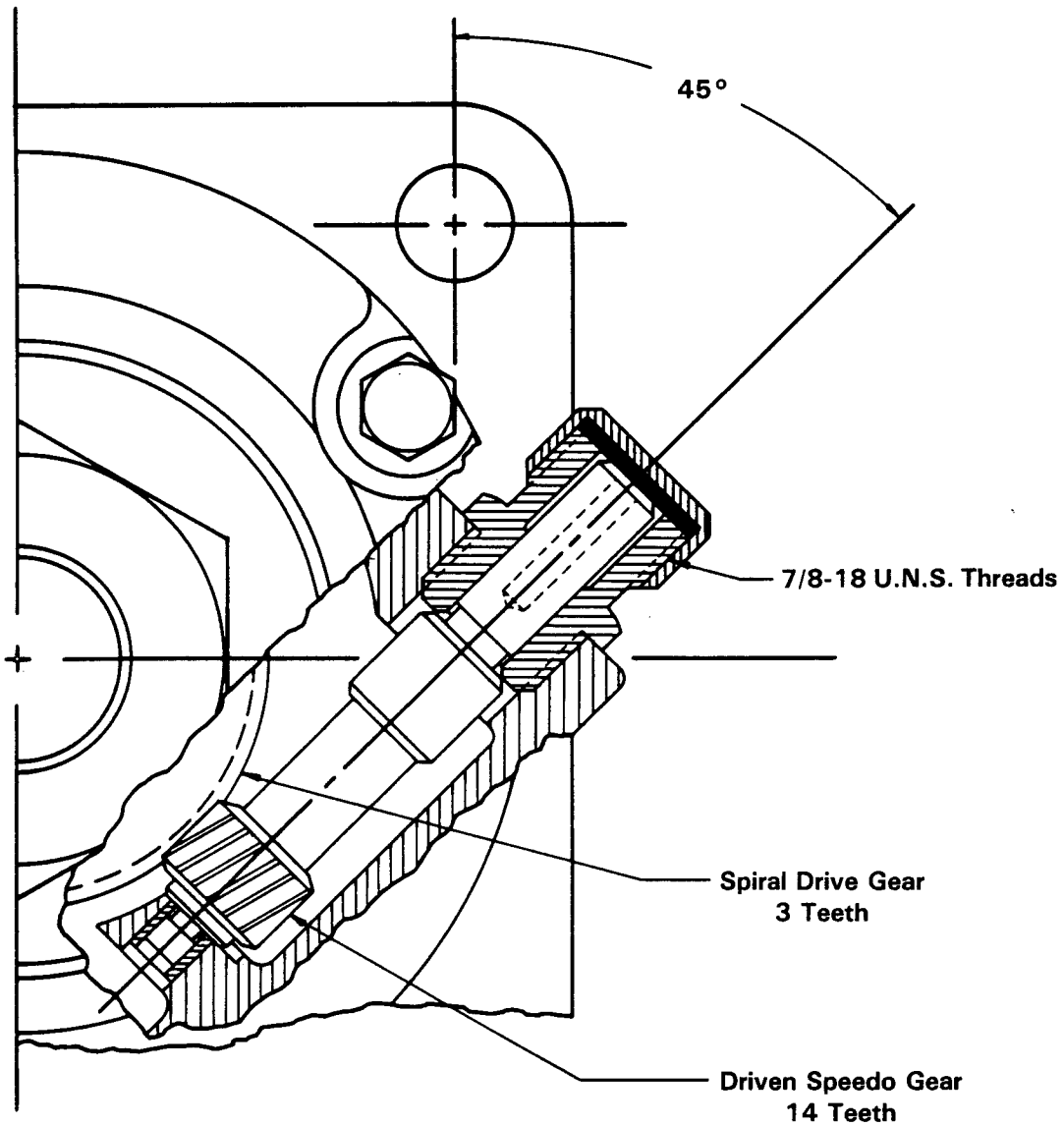

Figure 4. Speedometer Drive Detail

When mounted on the pump, the rear cross member must not extend over the pump discharge port or in any way impede access to the port; pump serviceability will be affected otherwise.

The drive input end of the gearbox is fitted with a rubber-mounted machine flange identified as a trunnion bracket. Mount the trunnion bracket to a front cross member (not supplied with the pump) to provide support to the drive input end of the pump. When mounting the trunnion bracket, make certain that it will not interfere with air shift connections.

Position the rear and front cross members and mounted pump on the side rails of the chassis. Do not secure the cross members to the side rails before aligning the pump split shaft with the power input and output shafts (see **Alignment**). The rear cross member must be mounted with rubber or other vibration-resistant material when secured to the side rails; since the trunnion bracket has an integral rubber mounting, the front cross member does not require vibration-resistant mounting.

### Drive Flanges

This pump is furnished with mounted drive flanges which accommodate Spicer, or equivalent, universal joints. See figure 5 for drive flange dimensions.

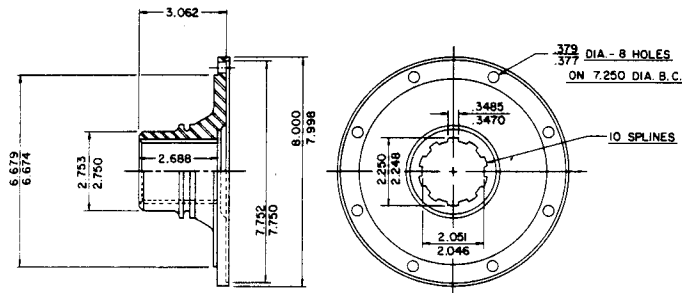

OUTPUT FLANGE  
GORMAN-RUPP PART NO.  
S-2272-A

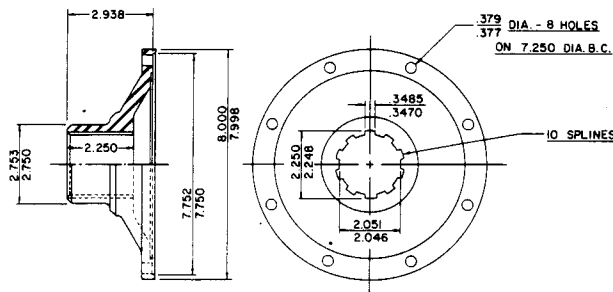

INPUT FLANGE  
GORMAN-RUPP PART NO.  
S-2271

Figure 5. Drive Flange Dimensions

This pump is furnished with a heavy-duty gearbox, split shaft, and companion drive flanges; previous Gorman-Rupp pumps in this series were furnished with a standard-duty gearbox, split shaft, and companion drive flanges. The drive flanges mounted on this pump will not accommodate the universal joint assemblies used with previous standard-duty gearbox pumps.

If this pump is to be used as a replacement for a standard-duty gearbox pump in an existing installation, the universal joint to drive flange connections must be modified through installation of adaptor flange yokes furnished in Gorman-Rupp Kit No. 48123-001 (see figure 6).

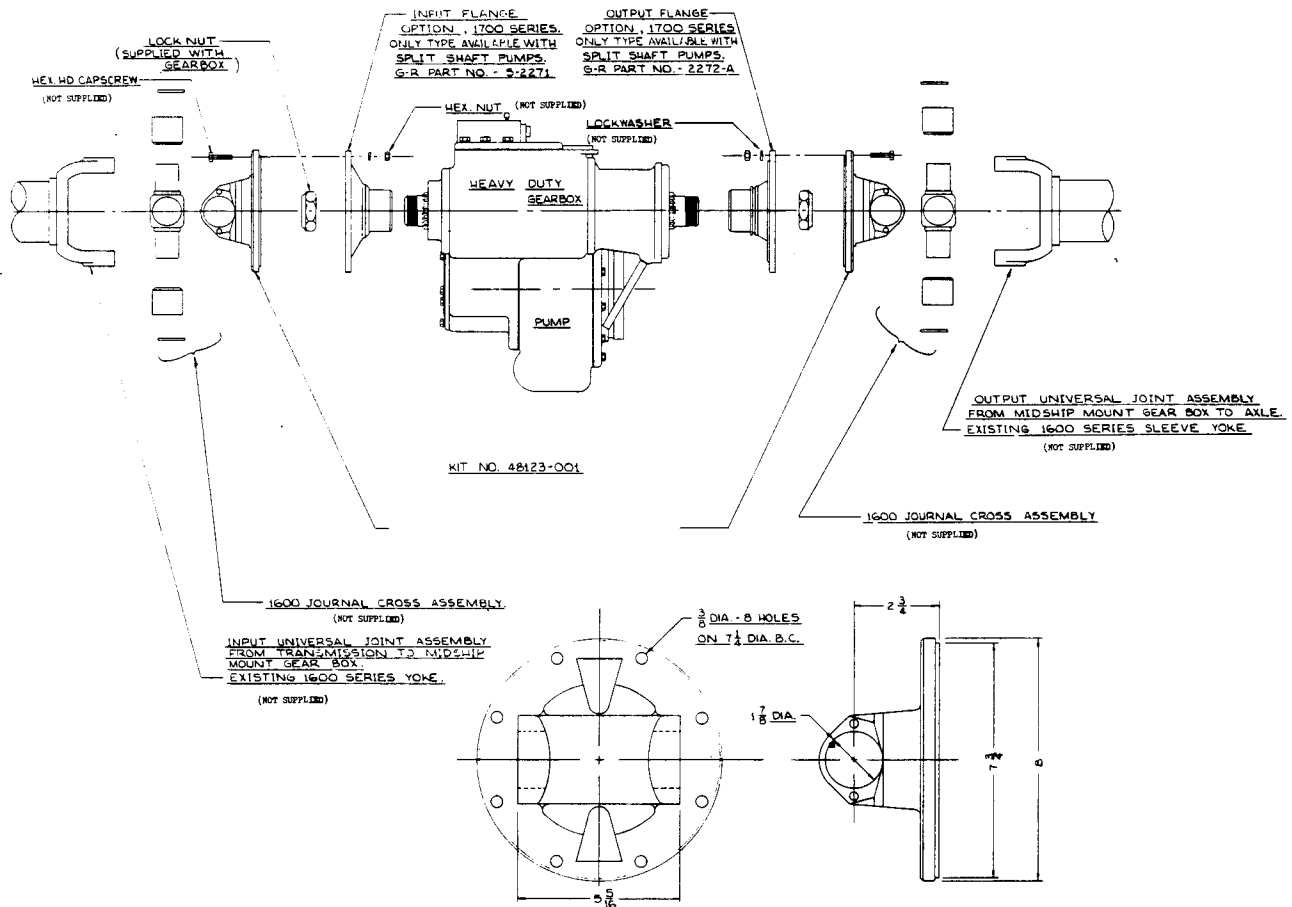

Figure 6. Adaptor Flange Yoke Installation



### Automatic Transmissions

At the time of shifting from pump to vehicle operation or vice versa, the power input shaft should be rotating no more than 15 RPM. In vehicles using automatic transmissions, installation of a brake is recommended to prevent excessive power input shaft rotation and raking of gears.

### Drive Shaft Connections

For maximum pump efficiency, joint angles at drive connections should be kept within recommended minimums. A minimum angle of 1 degree is necessary for circulation of the needle bearings in the universal joints, but excessive angles will cause accelerated wear and loss of speed (see table 1).

Joint Angle	Speed
5 degrees	5000 RPM
6 degrees, 30 minutes	4000 RPM
8 degrees	3000 RPM

**Table 1. Joint Angle/RPM Ratio (maximum)**

The slip joint connecting the power input shaft to the drive flanges of the gearbox input shaft flanges should be installed at equal joint angles of less than 3 degrees.

A double joint with slip must be installed to connect the power output shaft to the drive flanges of the gearbox output shaft. The joint angles should be kept within 1 to 3 degrees, and the equal joint angles should be less than 8 degrees.

### Alignment

Position the cross members and mounted pump on the side rails of the vehicle, and adjust the entire assembly so that the angles of the drive shaft connections are kept to a minimum. For optimum pump performance, the centerline of the gearbox input and output shafts should be within 1 degree of the centerline of power input and output shafts.

### CAUTION

When positioning and securing the pump to the chassis, care should be taken that the gearbox will not be placed in a bind between the input and output power drive shafts; pump bearing failure or gearbox breakdown could result otherwise.

Mount the rear cross member with a cushion of rubber, or other shock-resistant material, and secure the cross members to the side rails of the vehicle chassis.

Assemble, straighten, and balance the input and output power drive shafts. Angles at the drive shaft connections should be in one plane, and should be less than 3 degrees at the drive input, and less than 8 degrees at the drive output.

### Piping

Suction lines should be as short and straight as possible in order to minimize friction loss.

In order to avoid wracking of the piping, it is recommended that flexible connections such as the victaulic type or bellows be installed at pump suction and discharge.

Do not tighten connecting flanges unless they are properly aligned. Never pull a line into place by tightening the flange bolts.

### Air Shift Connections

Proper operation of the gearbox air shift requires an air cylinder with air pressure of 70 to 140 psi. Use air lines of one-quarter inch. The air line connection at the end cap of the air cylinder is for vehicle operation, and the air line connection at the top of the air shifter cover is for pump operation. Seal all hose fittings with Pematex or equivalent compound.

### Lubrication

The seal assembly is lubricated by the medium being pumped.

See complete lubrication for the gearbox in LUBRICATION, Section 1. **Do not attempt to operate the pump before adding lubricant to the gearbox.**

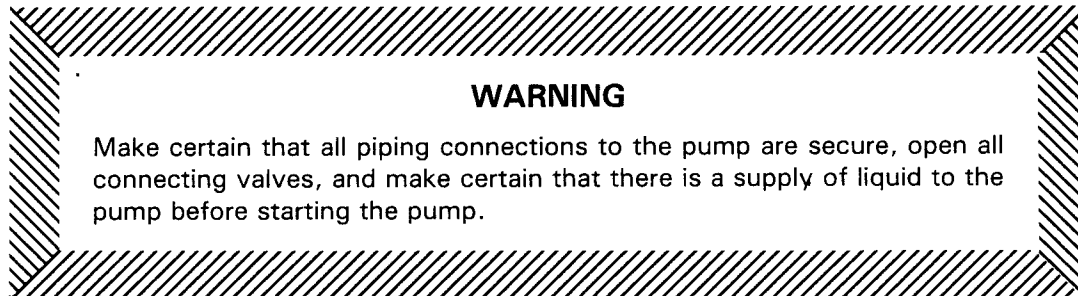

**WARNING**

Make certain that all piping connections to the pump are secure, open all connecting valves, and make certain that there is a supply of liquid to the pump before starting the pump.

### OPTIONS

The following optional equipment is available for this pump:

P/N S-2275 Air Shifter Connections Kit. This is **not** a conversion kit. If a conversion from manual shift to air shift, or vice versa, is desired, contact your Gorman-Rupp representative, or the Gorman-Rupp factory.

P/N 48123-003 Parts Kit to rotate the gearbox 90 degrees.

A factory-modified version of this pump with an auxiliary stub shaft power take off is available. See figure 7 for outline drawings and dimensions.

GEAR RATIO - STUB SHAFT 1.32 : 1 INCREASE  
PUMP SHAFT 2.56 : 1 INCREASE

400 IN. LBS. MAX. TORQUE RECOMMENDED FOR STUB SHAFT.  
[45,2 N. m.]

STUB SHAFT ROTATES ONLY WHEN GEARBOX IS IN  
PUMP POSITION.

FACTORY MODIFICATION BY GORMAN-RUPP ONLY.

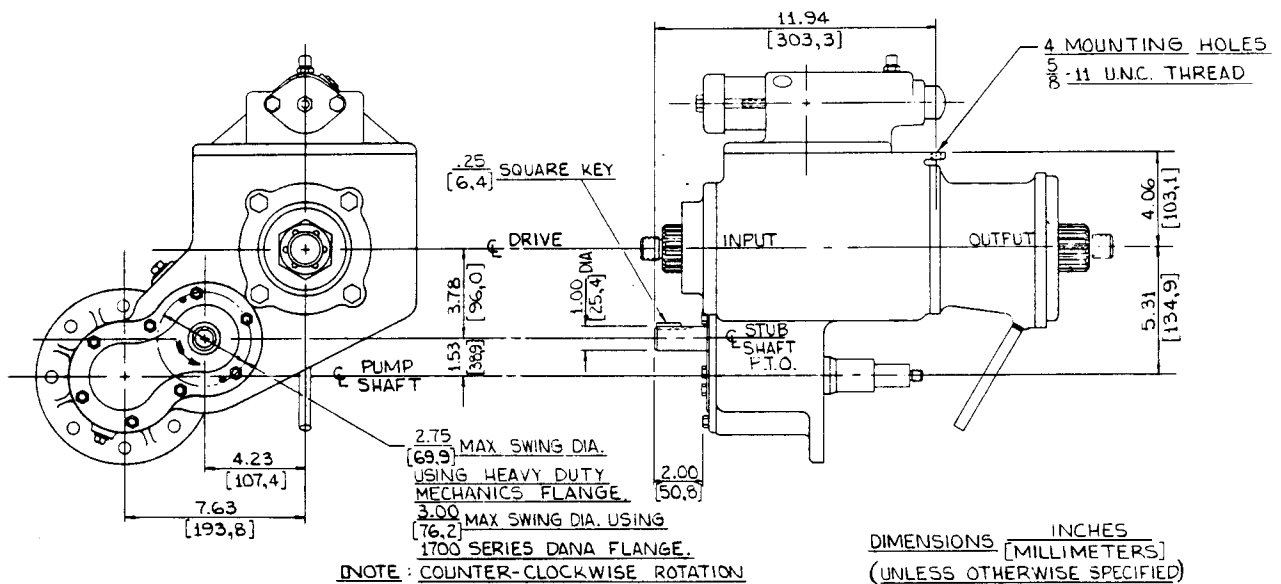

Figure 7. Typical O6 Pump Model With Stub Shaft PTO  
(Modified Version Available From Factory Only)

**For U.S. and International Warranty Information,  
Please Visit [www.grpumps.com/warranty](http://www.grpumps.com/warranty)  
or call:  
U.S.: 419-755-1280  
International: +1-419-755-1352**

**For Canadian Warranty Information,  
Please Visit [www.grcanada.com/warranty](http://www.grcanada.com/warranty)  
or call:  
519-631-2870**