**INSTALLATION, OPERATION,
AND MAINTENANCE MANUAL**
WITH PARTS LIST



O SERIES PUMPS

MODEL
04B3-(UD282)

THE GORMAN-RUPP COMPANY • MANSFIELD, OHIO

GORMAN-RUPP OF CANADA LIMITED • ST. THOMAS, ONTARIO, CANADA Printed in U.S.A.

©Copyright by the Gorman-Rupp Company

TABLE OF CONTENTS

INTRODUCTION	I-1
WARNINGS - SECTION A	A-1
INSTALLATION - SECTION B	B-1
PREINSTALLATION INSPECTION	B-1
POSITIONING PUMP	B-2
Lifting	B-2
Mounting	B-2
SUCTION AND DISCHARGE PIPING	B-2
Materials	B-2
Line Configuration	B-3
Connections to Pump	B-3
Gauges	B-3
SUCTION LINES	B-3
Fittings	B-3
Strainers	B-4
Sealing	B-4
Suction Lines In Sumps	B-4
Suction Line Positioning	B-4
DISCHARGE LINES	B-5
Siphoning	B-5
Valves	B-6
Bypass Lines	B-6
ALIGNMENT	B-6
OPERATION - SECTION C	C-1
PRIMING	C-1
STARTING	C-2
OPERATION	C-2
Lines With a Bypass	C-2
Lines Without a Bypass	C-2
Leakage	C-3
Liquid Temperature And Overheating	C-3
Strainer Check	C-3
Pump Vacuum Check	C-4
STOPPING	C-4
Cold Weather Preservation	C-4
BEARING TEMPERATURE CHECK	C-5
PUMP TROUBLESHOOTING - SECTION D	D-1
PUMP MAINTENANCE AND REPAIR - SECTION E	E-1
PERFORMANCE CURVE	E-1
PUMP MODEL - PARTS LIST	E-3
PUMP AND SEAL DISASSEMBLY AND REASSEMBLY	E-4
Pump Disassembly	E-4
Impeller Removal	E-5
Seal Removal And Disassembly	E-5
Separating Intermediate From Engine	E-5
Shaft And Bearing Removal And Disassembly	E-6
Shaft and Bearing Reassembly And Installation	E-6
Securing Intermediate To Engine	E-8
Seal Installation	E-8
Impeller Installation	E-11
Pump Reassembly	E-12
Final Pump Reassembly	E-12
LUBRICATION	E-12
Seal Assembly	E-12
Bearings	E-12
Engine	E-13

INTRODUCTION

This Installation, Operation, and Maintenance Manual is designed to help you achieve the best performance and longest life from your Gorman-Rupp pump.

This pump is an O Series, closed impeller, self-priming centrifugal model. The pump is designed with straight-in suction, without a suction check valve. The pump is suitable for pumping liquids that do not contain large solids. The basic material of construction for wetted parts is gray iron, with bronze impeller and gray iron wear rings.

If there are any questions regarding the pump or its application which are not covered in this manual or in other literature accompanying this unit, please contact your Gorman-Rupp distributor, or write:

The Gorman-Rupp Company	or	Gorman-Rupp of Canada Limited
P.O. Box 1217		70 Burwell Road
Mansfield, Ohio 44901-1217		St. Thomas, Ontario N5P 3R7

For information or technical assistance on the engine, contact the engine manufacturer's local dealer or representative.

The following are used to alert maintenance personnel to procedures which require special attention, to those which could damage equipment, and to those which could be dangerous to personnel:

NOTE

Instructions to aid in installation, operation, and maintenance or which clarify a procedure.

CAUTION

Instructions which must be followed to avoid causing damage to the product or other equipment incidental to the installation. These instructions describe the requirements and the possible damage which could result from failure to follow the procedures.

WARNING

```

////////////////////////////////////
//                               //
// These instructions must be followed to avoid causing in- //
// jury or death to personnel, and describe the procedure //
// required and the injury which could result from failure //
// to follow the procedure. //
//                               //
////////////////////////////////////

```

WARNINGS

WARNINGS - SECTION A

THESE WARNINGS APPLY TO 0 SERIES ENGINE DRIVEN PUMPS. REFER TO THE MANUAL ACCOMPANYING THE ENGINE BEFORE ATTEMPTING TO BEGIN OPERATION.

WARNING

```

////////////////////////////////////
// Before attempting to open or service the pump: //
// //
// 1. Familiarize yourself with this manual. //
// 2. Switch off the engine ignition and remove the key //
// to ensure that the pump will remain inoperative. //
// 3. Allow the pump to cool if overheated. //
// 4. Vent the pump slowly and cautiously. //
// 5. Close the suction and discharge valves. //
// 6. Check the temperature before opening any covers, //
// plates, or plugs. //
// 7. Drain the pump. //
////////////////////////////////////

```

WARNING

```

////////////////////////////////////
// This pump is designed to handle clean liquids containing //
// specified entrained solids. Do not attempt to pump vol- //
// atile, corrosive, or flammable liquids which may damage //
// the pump or endanger personnel as a result of pump fail- //
// ure. //
////////////////////////////////////

```

WARNING

```

////////////////////////////////////
// After the pump has been installed, make certain that the //
// pump and all piping connections are tight, properly sup- //
// ported and secure before operation. //
////////////////////////////////////

```

WARNING

```

////////////////////////////////////
// Do not operate the pump against a closed discharge valve //
// for long periods of time. This could bring the liquid //
// to a boil, build pressure, and cause the pump to rupture //
// or explode. //
////////////////////////////////////

```

WARNINGS

WARNING

```

////////////////////////////////////
//
// Do not remove plates, covers, gauges, pipe plugs, or //
// fittings from an overheated pump. Vapor pressure within //
// the pump can cause parts being disengaged to be ejected //
// with great force. Allow the pump to cool before servic- //
// ing. //
// //
////////////////////////////////////

```

WARNING

```

////////////////////////////////////
//
// Do not operate an internal combustion engine in an ex- //
// plosive atmosphere. When operating internal combustion //
// engines in an enclosed area, make certain that exhaust //
// fumes are piped to the outside. These fumes contain //
// carbon monoxide, a deadly gas that is colorless, //
// tasteless, and odorless. //
// //
////////////////////////////////////

```

WARNING

```

////////////////////////////////////
//
// Never tamper with the governor to gain more power. The //
// governor establishes safe operating limits that should //
// not be exceeded. //
// //
////////////////////////////////////

```

WARNING

```

////////////////////////////////////
//
// Overheated pumps can cause severe burns and injury. If //
// overheating of the pump occurs: //
// //
// 1. Stop the pump immediately. //
// 2. Allow the pump to cool. //
// 3. Refer to instructions in this manual before re- //
// starting the pump. //
// //
////////////////////////////////////

```

WARNING

```

////////////////////////////////////
//
// Do not remove plates, covers, gauges, pipe plugs, or //
// fittings from an overheated pump. Vapor pressure within //
// the pump can cause parts being disengaged to be ejected //
// with great force. Allow the pump to cool before servic- //
// ing. //
// //
////////////////////////////////////

```

WARNING

```
////////////////////////////////////  
//  
// Fuel used by internal combustion engines presents an ex- //  
// tremе explosion and fire hazard. Make certain that all //  
// fuel lines are securely connected and free of leaks. //  
// Never refuel a hot or running engine. Avoid overfilling //  
// the fuel tank. Always use the correct type of fuel. //  
// //  
////////////////////////////////////
```

WARNING

```
////////////////////////////////////  
//  
// Use lifting and moving equipment in good repair and with //  
// adequate capacity to prevent injuries to personnel or //  
// damage to equipment. //  
// //  
////////////////////////////////////
```

INSTALLATION - SECTION B

Since pump installations are seldom identical, this section offers only general recommendations and practices required to inspect, position, and arrange the pump and piping.

Most of the information pertains to a standard **static lift application** where the pump is positioned above the free level of liquid to be pumped.

If installed in a **flooded suction application** where the liquid is supplied to the pump under pressure, some of the information such as mounting, line configuration, and priming must be tailored to the specific application. Since the pressure supplied to the pump is critical to performance and safety, **be sure** to limit the incoming pressure to 50% of the maximum permissible operating pressure as shown on the pump performance curve.

For further assistance, contact your Gorman-Rupp distributor or the Gorman-Rupp Company.

PREINSTALLATION INSPECTION

The pump assembly was inspected and tested before shipment from the factory. Before installation, inspect the pump for damage which may have occurred during shipment. Check as follows:

- a. Inspect the pump for cracks, dents, damaged threads, and other obvious damage.
- b. Check for and tighten loose bolts, nuts, capscrews, and other attaching hardware. Since gaskets tend to shrink after drying, check for and tighten loose nuts and capscrews securing mating surfaces.
- c. Carefully read all tags, decals, and markings on the pump assembly, and follow the instructions indicated.
- d. Check all lubricant levels and lubricate as necessary. Refer to LUBRICATION in the MAINTENANCE AND REPAIR section of this manual and perform duties as instructed.
- e. If the pump and engine have been stored for more than 12 months, some of the components or lubricants may have exceeded their maximum shelf life. These **must be inspected or replaced** to ensure maximum pump service.

If the maximum shelf life has been exceeded, or if anything appears to be abnormal, contact your Gorman-Rupp distributor or the factory to determine the repair or updating policy. **Do not** put the pump into service until appropriate action has been taken.

POSITIONING PUMP

Lifting

Use lifting equipment with a capacity of a least **2,125 pounds**. This pump weighs approximately **425 pounds**, not including the weight of accessories and customer installed options. Customer installed equipment such as suction and discharge hoses **must** be removed before attempting to lift.

CAUTION

The pump assembly can be seriously damaged if the cables or chains used to lift and move the unit are improperly wrapped around the pump.

Mounting

Locate the pump in an accessible place as close as practical to the liquid being pumped. Level mounting is essential for proper operation. The pump may have to be supported or shimmed to provide for level operation or to eliminate vibration.

To ensure sufficient lubrication and fuel supply to the engine, **do not** position the pump and engine more than 15° off horizontal for continuous operation. The pump and engine may be positioned up to 30° off horizontal for **intermittant operation only**; however, the engine manufacturer should be consulted for continuous operation at angles greater than 15°.

If the pump has been mounted on a moveable base, make certain the base is stationary by setting the brake and blocking the wheels before attempting to operate the pump.

SUCTION AND DISCHARGE PIPING

Materials

Either pipe or hose may be used for suction and discharge lines; however, the materials must be compatible with the liquid being pumped. If hose is used in suction lines, it must be the rigid-wall, reinforced type to prevent collapse under suction. Using piping couplings in suction lines is not recommended.

Line Configuration

Keep suction and discharge lines as straight as possible to minimize friction losses. Make minimum use of elbows and fittings, which substantially increase friction loss. If elbows are necessary, use the long-radius type to minimize friction loss.

Connections to Pump

Before tightening a connecting flange, align it exactly with the pump port. Never pull a pipe line into place by tightening the flange bolts and/or couplings.

Lines near the pump must be independently supported to avoid strain on the pump which could cause excessive vibration; decreased bearing life, and increased shaft and seal wear. If hose-type lines are used, they should have adequate support to secure them when filled with liquid and under pressure.

Gauges

Most pumps are drilled and tapped for installing discharge pressure and vacuum suction gauges. If these gauges are desired for pumps that are not tapped, drill and tap the suction and discharge lines not less than 18 inches from the suction and discharge ports and install the lines. Installation closer to the pump may result in erratic readings.

SUCTION LINES

To avoid air pockets which could affect pump priming, the suction line must be as short and direct as possible. When operation involves a suction lift, the line must always slope upward to the pump from the source of the liquid being pumped; if the line slopes down to the pump at any point along the suction run, air pockets will be created.

Fittings

Suction lines should be the same size as the pump inlet. If reducers are used in suction lines, they should be the eccentric type, and should be installed with the flat part of the reducers uppermost to avoid creating air pockets. Valves are not normally used in suction lines, but if a valve is used, install it with the stem horizontal to avoid air pockets.

Strainers

If a strainer is furnished with the pump, be certain to use it; any spherical solids which pass through a strainer furnished with the pump will also pass through the pump itself.

If a strainer is not furnished with the pump, but is installed by the pump user, make certain that the total area of the openings in the strainer is at least three or four times the cross section of the suction line, and that the openings will not permit passage of solids larger than the solids handling capability of the pump.

This pump is designed to handle up to 1/2 inch diameter spherical solids.

Sealing

Since even a slight leak will affect priming, head, and capacity, especially when operating with a high suction lift, all connections in the suction line should be sealed with pipe dope to ensure an airtight seal. Follow the sealant manufacturer's recommendations when selecting and applying the pipe dope. The pipe dope should be compatible with the liquid being pumped.

Suction Lines In Sumps

If a single suction line is installed in a sump, it should be positioned away from the wall of the sump at a distance equal to one and one-half times the diameter of the suction line.

If there is a liquid flow from an open pipe into the sump, the flow should be kept away from the suction inlet because the inflow will carry air down into the sump, and air entering the suction line will reduce pump efficiency.

If it is necessary to position inflow close to the suction inlet, install a baffle between the inflow and the suction inlet at a distance one and one-half times the diameter of the suction pipe. The baffle will allow entrained air to escape from the liquid before it is drawn into the suction inlet.

If two suction lines are installed in a single sump, the flow paths may interact, reducing the efficiency of one or both pumps. To avoid this, position the suction inlets so that they are separated by a distance equal to at least three times the diameter of the suction pipe.

Suction Line Positioning

The depth of submergence of the suction line is critical to efficient pump operation. Figure 1 shows recommended minimum submergence vs. velocity.

NOTE

The pipe submergence required may be reduced by installing a standard pipe increaser fitting at the end of the suction line. The larger opening size will reduce the inlet velocity. Calculate the required submergence using the following formula based on the increased opening size (area or diameter).

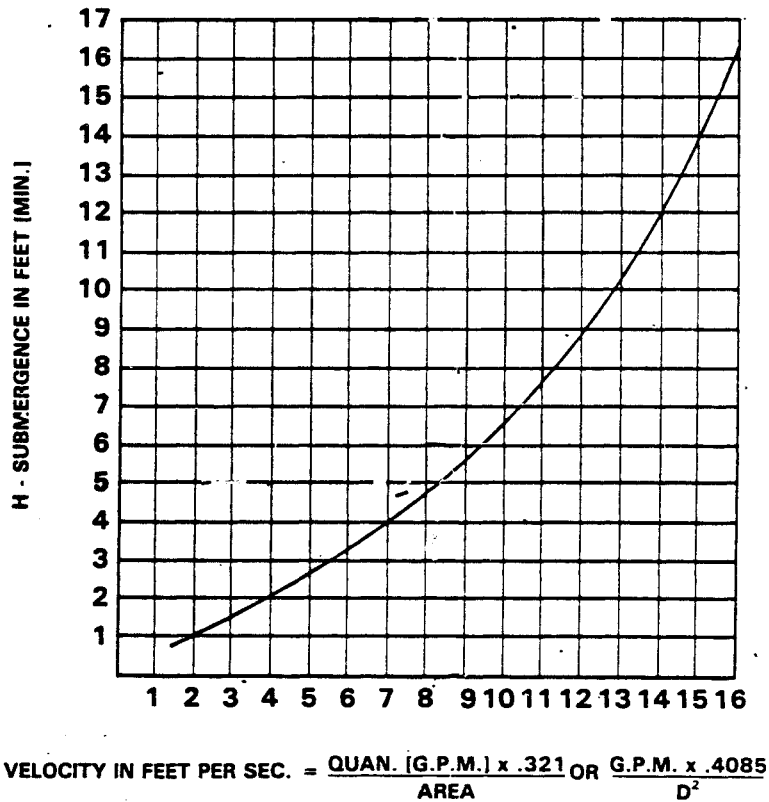

Figure 1. Recommended Minimum Suction Line Submergence Vs. Velocity

DISCHARGE LINES

Siphoning

Do not terminate the discharge line at a level lower than that of the liquid being pumped unless a siphon breaker is used in the line. Otherwise, a siphoning action causing damage to the pump could result.

Valves

If a throttling valve is desired in the discharge line, use a valve as large as the largest pipe to minimize friction losses. Never install a throttling valve in a suction line.

With high discharge heads, it is recommended that a throttling valve and a system check valve be installed in the discharge line to protect the pump from excessive shock pressure and reverse rotation when it is stopped.

Bypass Lines

If it is necessary to permit the escape of air to atmosphere during initial priming or in the repriming cycle, install a bypass line between the pump and the discharge check valve. The bypass line should be sized so that it does not affect pump discharge capacity.

Either a Gorman-Rupp automatic air release valve - which will automatically open to allow the pump to prime, and automatically close when priming is accomplished - or a hand-operated shutoff valve should be installed in the bypass line.

NOTE

The bypass line may clog frequently, particularly if the valve remains closed. If this condition occurs, either use a larger bypass line or leave the shutoff valve open during the pumping operation.

Do not terminate the discharge line at a level lower than that of the liquid being pumped unless a siphon breaker is used in the line. Otherwise, a siphoning action could result, causing damage to the pump.

ALIGNMENT

The alignment of the pump and the engine is critical for trouble free mechanical operation. See Section E, **Securing Intermediate To Engine** for detailed information.

OPERATION - SECTION C

WARNING

```

////////////////////////////////////
//
// This pump is designed to handle clean liquids containing
// specified entrained solids. Do not attempt to pump vol-
// atile, corrosive, or flammable liquids which may damage
// the pump or endanger personnel as a result of pump fail-
// ure.
//
////////////////////////////////////

```

WARNING

```

////////////////////////////////////
//
// Never tamper with the governor to gain more power. The
// governor establishes safe operating limits that should
// not be exceeded.
//
////////////////////////////////////

```

PRIMING

Install the pump and piping as described in **INSTALLATION**. Make sure that the piping connections are tight, and that the pump is securely mounted. Check that the pump is properly lubricated (see **LUBRICATION** in **MAINTENANCE AND REPAIR**).

This pump is self-priming, but the pump should never be operated unless there is liquid in the casing.

CAUTION

<p>Never operate a self-priming pump unless there is liquid in the casing. The pump will not prime when dry. Extended operation of a dry pump will destroy the seal assembly.</p>

Add liquid to the pump casing when:

1. The pump is being put into service for the first time.
2. The pump has not been used for a considerable length of time.
3. The liquid in the pump casing has evaporated.

Once the pump casing has been filled, the pump will prime and reprime as necessary.

WARNING

```

////////////////////////////////////
//
// After filling the pump casing, reinstall and tighten the //
// fill plug. Do not attempt to operate the pump unless //
// all connecting piping is securely installed. Otherwise, //
// liquid in the pump forced out under pressure could cause //
// injury to personnel. //
// //
////////////////////////////////////

```

To fill the pump, remove the pump casing fill cover or fill plug at the top of the casing and add clean liquid until the pump is filled. Replace the fill cover or fill plug before operating the pump.

STARTING

Consult the operations manual furnished with the engine.

OPERATION

Lines With a Bypass

Either a Gorman-Rupp automatic air release valve or a hand operated shutoff valve may be installed in a bypass line.

If a Gorman-Rupp automatic air release valve has been installed, close the throttling valve in the discharge line. The Gorman-Rupp valve will automatically open to allow the pump to prime, and automatically close when priming has been accomplished. After the pump has been primed, and liquid is flowing steadily from the bypass line, open the discharge throttling valve.

If a hand operated shutoff valve has been installed, close the throttling valve in the discharge line, and open the bypass shutoff valve so that the pump will not have to prime against the weight of the liquid in the discharge line. When the pump has been primed, and liquid is flowing steadily from the bypass line, close the bypass shutoff valve and open the discharge throttling valve.

Lines Without a Bypass

Open all valves in the discharge line and start the power source. Priming is indicated by a positive reading on the discharge pressure gauge or by a quieter operation. The pump may not prime immediately because the suction line must first fill with liquid. If the pump fails to prime within five minutes, stop it and check the suction line for leaks.

After the pump has been primed, partially close the discharge line throttling valve in order to fill the line slowly and guard against excessive shock pres-

sure which could damage pipe ends, gaskets, sprinkler heads, and any other fixtures connected to the line. When the discharge line is completely filled, adjust the throttling valve to the required flow rate.

Leakage

No leakage should be visible at pump mating surfaces, or at pump connections or fittings. Keep all line connections and fittings tight to maintain maximum pump efficiency.

Liquid Temperature And Overheating

The maximum liquid temperature for this pump is 160° F. Do not apply it at a higher operating temperature.

Overheating can occur if operated with the valves in the suction or discharge lines closed. Operating against closed valves could bring the liquid to a boil, build pressure, and cause the pump to rupture or explode. If overheating occurs, stop the pump and allow it to cool before servicing it. Refill the pump casing with cool liquid.

WARNING

Warning text enclosed in a double-line border with slashes. The text reads: 'Do not remove plates; covers, gauges, pipe plugs, or fittings from an overheated pump. Vapor pressure within the pump can cause parts being disengaged to be ejected with great force. Allow the pump to cool before servicing.'

Strainer Check

If a suction strainer has been shipped with the pump or installed by the user, check the strainer regularly, and clean it as necessary. The strainer should also be checked if pump flow rate begins to drop. If a vacuum suction gauge has been installed, monitor and record the readings regularly to detect strainer blockage.

Never introduce air or steam pressure into the pump casing or piping to remove a blockage. This could result in personal injury or damage to the equipment. If backflushing is absolutely necessary, liquid pressure must be limited to 50% of the maximum permissible operating pressure shown on the pump performance curve.

OPERATION

Pump Vacuum Check

Since this pump does not have a suction check valve, the discharge line must be fitted with a check valve if a pump vacuum reading is to be taken.

With the pump inoperative, install a vacuum gauge in the system, using pipe dope on the threads. Block the suction line and start the pump. At operating speed the pump should pull a vacuum of 20 inches or more of mercury. If it does not, check for air leaks in the seal, gasket, or discharge valve.

Open the suction line, and read the vacuum gauge with the pump primed and at operating speed. Shut off the pump. The vacuum gauge reading will immediately drop proportionate to static suction lift, and should then stabilize. If the vacuum reading falls off rapidly after stabilization, an air leak exists. Before checking for the source of the leak, check the point of installation of the vacuum gauge.

STOPPING

Never halt the flow of liquid suddenly. If the liquid being pumped is stopped abruptly, damaging shock waves can be transmitted to the pump and piping system. Close all connecting valves slowly. On engine driven pumps, reduce the throttle speed slowly and allow the engine to idle briefly before stopping.

CAUTION

- If application involves a high discharge head, gradually close the discharge throttling valve before stopping the pump.

After stopping the pump, switch off the engine ignition and remove the key to ensure that the pump will remain inoperative.

Cold Weather Preservation

In below freezing conditions, drain the pump to prevent damage from freezing. Also, clean out any solids by flushing with a hose. Operate the pump for approximately one minute; this will remove any remaining liquid that could freeze the pump rotating parts.

If the pump will be idle for more than a few hours, or if it has been pumping liquids containing a large amount of solids, drain the pump, and flush it thoroughly with clean water. To prevent large solids from clogging the drain port and preventing the pump from completely draining, insert a rod or stiff wire in the drain port, and agitate the liquid during the draining process. Clean out any remaining solids by flushing with a hose.

BEARING TEMPERATURE CHECK

Bearings normally run at higher than ambient temperatures because of heat generated by friction. Temperatures up to 160°F are considered normal for bearings, and they can operate safely to at least 180°F.

Checking bearing temperatures by hand is inaccurate. Bearing temperatures can be measured accurately by placing a contact-type thermometer against the housing. Record this temperature for future reference.

A sudden increase in bearing temperatures is a warning that the bearings are at the point of failing to operate properly. Make certain that the bearing lubricant is of the proper viscosity and at the correct level (see LUBRICATION in MAINTENANCE AND REPAIR). Bearing overheating can also be caused by shaft misalignment and/or excessive vibration.

When pumps are first started, the bearings may seem to run at temperatures above normal. Continued operation should bring the temperatures down to normal levels.

PUMP TROUBLESHOOTING - SECTION D

WARNING

```

////////////////////////////////////
//
// Before attempting to open or service the pump:
//
// 1. Familiarize yourself with this manual.
// 2. Switch off the engine ignition and remove the key
//    to ensure that the pump will remain inoperative.
// 3. Allow the pump to cool if overheated.
// 4. Vent the pump slowly and cautiously.
// 5. Close the suction and discharge valves.
// 6. Check the temperature before opening any covers,
//    plates, or plugs.
// 7. Drain the pump.
//
////////////////////////////////////
    
```

TROUBLE	POSSIBLE CAUSE	PROBABLE REMEDY
PUMP FAILS TO PRIME	Air leak in suction line. Lining of suction hose collapsed. Leaking or worn seal or pump gasket. Suction lift or discharge head too high. Strainer clogged.	Correct leak. Replace suction hose. Check pump vacuum. Replace leaking or worn seal or gasket. Check piping installation and install bypass line if needed. See INSTALLATION. Check strainer and clean if necessary.
PUMP STOPS OR FAILS TO DELIVER RATED FLOW OR PRESSURE	Air leak in suction line. Suction intake not submerged at proper level or sump too small. Lining of suction hose collapsed. Impeller or other wearing parts worn or damaged.	Correct leak. Check installation and correct submergence as needed. Replace suction hose. Replace worn or damaged parts. Check that impeller is properly centered and rotates freely.

TROUBLE	POSSIBLE CAUSE	PROBABLE REMEDY
PUMP STOPS OR FAILS TO DELIVER RATED FLOW OR PRESSURE (cont.)	<p>Impeller clogged.</p> <p>Pump speed too slow.</p> <p>Discharge head too high.</p> <p>Suction lift too high.</p> <p>Strainer clogged.</p> <p>Leaking or worn seal or pump gasket.</p>	<p>Free impeller of debris.</p> <p>Check driver output; check belts or couplings for slippage.</p> <p>Install bypass line.</p> <p>Measure lift w/vacuum gauge. Reduce lift and/or friction losses in suction line.</p> <p>Check strainer and clean if necessary.</p> <p>Check pump vacuum. Replace leaking or worn seal or gasket.</p>
PUMP REQUIRES TOO MUCH POWER	<p>Pump speed too high.</p> <p>Discharge head too low.</p> <p>Liquid solution too thick.</p>	<p>Check driver output; check that sheaves or couplings are correctly sized.</p> <p>Adjust discharge valve.</p> <p>Dilute if possible.</p>
PUMP CLOGS FREQUENTLY	<p>Discharge flow too slow.</p> <p>Liquid solution too thick.</p>	<p>Open discharge valve fully to increase flow rate, and run engine at maximum governed speed.</p> <p>Dilute if possible.</p>
EXCESSIVE NOISE	<p>Cavitation in pump.</p> <p>Pumping entrained air.</p> <p>Pump or drive not securely mounted.</p> <p>Impeller clogged or damaged.</p>	<p>Reduce suction lift and/or friction losses in suction line. Record vacuum and pressure gauge readings and consult local representative or factory.</p> <p>Locate and eliminate source of air bubble.</p> <p>Secure mounting hardware.</p> <p>Clean out debris; replace damaged parts.</p>

TROUBLE	POSSIBLE CAUSE	PROBABLE REMEDY
BEARINGS RUN TOO HOT	Bearing temperature is high, but within limits. Low or incorrect lubricant. Suction and discharge lines not properly supported. Drive misaligned.	Check bearing temperature regularly to monitor any increase. Check for proper type and level of lubricant. Check piping installation for proper support. Align drive properly.

PUMP MAINTENANCE AND REPAIR - SECTION E

MAINTENANCE AND REPAIR OF THE WEARING PARTS OF THE PUMP WILL MAINTAIN PEAK OPERATING PERFORMANCE.

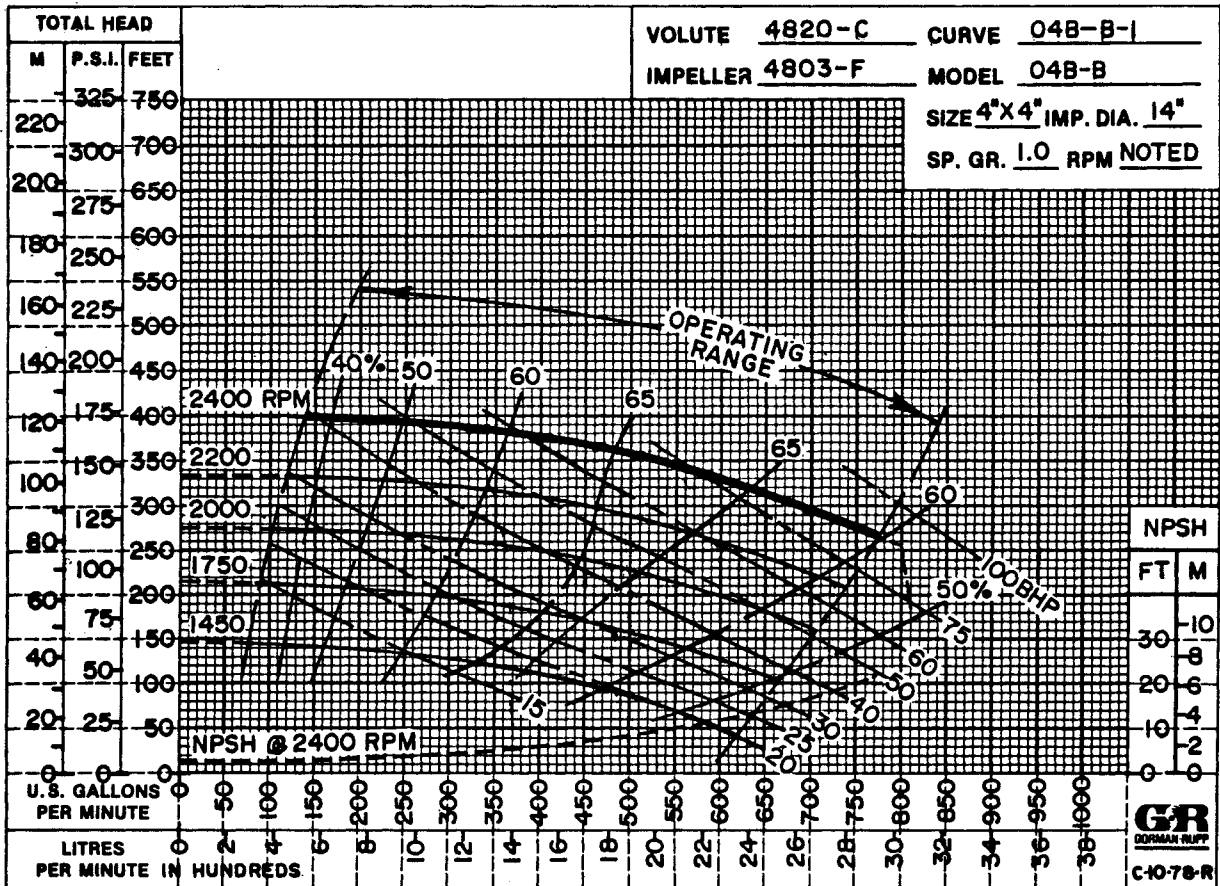

*STANDARD PERFORMANCE FOR PUMP MODEL 04B3-(UD282)

*Based on 70°F clear water at sea level with minimum suction lift. Since pump installations are seldom identical, your performance may be different due to such factors as viscosity, specific gravity, elevation, temperature, and impeller trim.

If your pump serial number is followed by an "N", your pump is NOT a standard production model. Contact the Gorman-Rupp Company to verify performance or part numbers.

WARNING

```

////////////////////////////////////
//
// Never tamper with the governor to gain more power. The
// governor establishes safe operating limits that should
// not be exceeded.
//
////////////////////////////////////

```

SECTIONAL DRAWING

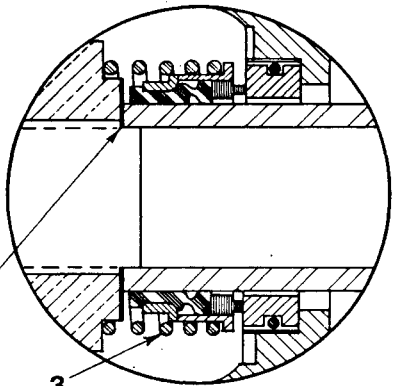
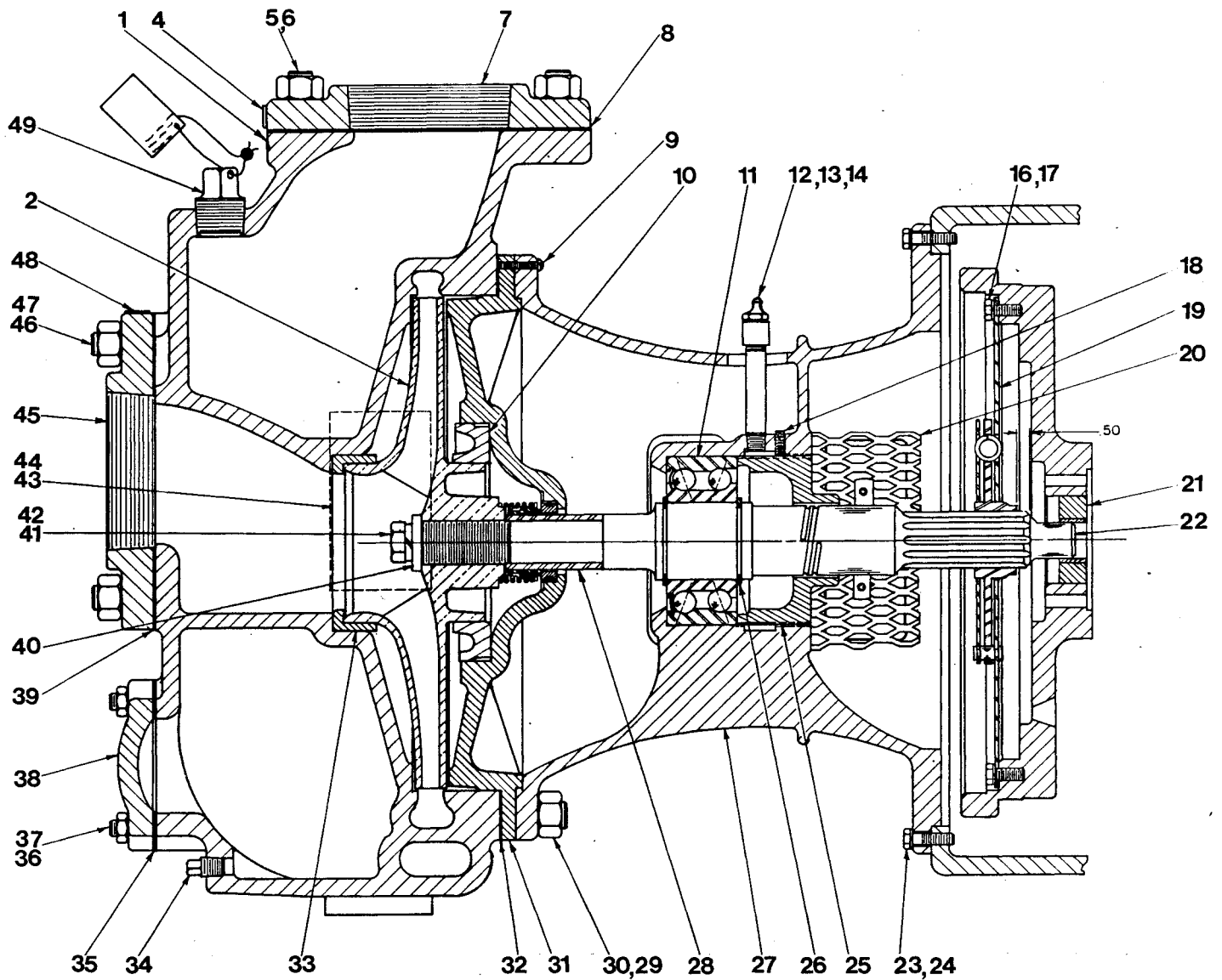

Figure 1. Pump Model 04B3-(UD282)

MAINTENANCE AND REPAIR

PARTS LIST
PUMP MODEL 04B3-(UD282)
 (From S/N 835568 up)

If your pump serial number is followed by an "N", your pump is NOT a standard production model. Contact the Gorman-Rupp Company to verify part numbers.

ITEM NO.	PART NAME	PART NUMBER	MATL CODE	QTY	ITEM NO.	PART NAME	PART NUMBER	MATL CODE	QTY
1	PUMP CASING	4820-C	10010	1	26	BRG RET RING	S00215	-----	2
2	*IMPELLER	4803-F	14000	1	27	INTERMEDIATE	7765-A	10010	1
3	*MECH SEAL ASSY	25271-207	-----	1	28	*SHAFT SLEEVE	3428-D	17030	1
4	DISCHARGE STICKER	6588-BJ	00000	1	29	STUD	C01010	15991	12
5	STUD	C01009	15991	8	30	HEX NUT	D00010	15991	12
6	HEX NUT	D00010	15991	8	31	SEAL PLATE	5792	10010	1
7	DISCHARGE FLANGE	1756	10010	1	32	*CASING GSKT	4820-G	20000	1
8	*DISCH FLANGE GSKT	1676-GB	20000	1	33	*WEAR RING	3765-A	10010	1
9	RD HD MACH SCREW	X00404	17090	2	34	PIPE PLUG	P00006	11990	1
10	*WEAR RING	6902	10010	1	35	*COVER PLT GSKT	4822-G	20000	1
11	*BALL BEARING	S01031	-----	1	36	STUD	C00807	15991	6
12	PIPE NIPPLE	T00410	15070	1	37	HEX NUT	D00008	15991	6
13	LUBE FITTING	S00191	-----	1	38	COVER PLATE	4822	10010	1
14	PIPE COUPLING	AE00004	11990	1	39	*SUCTION FLANGE GSKT	1676-GB	20000	1
15	*IMP ADJ SHIM SET	37-J	17090	1	40	*IMPELLER WASHER	5718	15990	1
16	HEX HD CAPSCREW	B00603	15991	8	41	*IMP CAPSCREW	B01005	15991	1
17	LOCKWASHER	J00006	15991	8	42	*IMP LOCKWASHER	AK00010	15991	1
18	ALLEN HD SETSCREW	GA00403	15990	1	43	NAME PLATE	38818-018	13990	1
19	DRIVE PLATE ASSY	24521-168	-----	1	44	DRIVE SCREW	BM#04-03	15990	4
20	INTERM GRD ASSY	42381-504	-----	2	45	SUCTION FLANGE	1756	10010	1
21	PILOT BUSHING ASSY	9208	-----	1	46	STUD	C01009	15991	8
22	*IMPELLER SHAFT	11233-A	16040	1	47	HEX NUT	D00010	15991	8
23	HEX HD CAPSCREW	B00605	15991	12	48	SUCTION STICKER	6588-AG	00000	1
24	LOCKWASHER	J00006	15991	12	49	FILL PLUG ASSY	48271-065	-----	1
25	BRG RET NUT	4329	10010	1					

*INDICATES PARTS RECOMMENDED FOR STOCK

Above Serial Numbers Do Not Apply To Pumps Made In Canada.

CANADIAN SERIAL NO AND UP

PUMP AND SEAL DISASSEMBLY AND REASSEMBLY

This pump requires little service due to its rugged, minimum-maintenance design. However, if it becomes necessary to inspect or replace the wearing parts, follow these instructions, which are keyed to the sectional view (see Figure 1) and the accompanying parts list.

Before attempting to service the pump, switch off the engine ignition and remove the key to ensure that the engine will remain inoperative, and close all valves in the suction and discharge lines.

The pump is designed to be powered by a six cylinder, 282 cubic inch displacement, International Harvester diesel engine, model UD282. For engine disassembly or repair, consult the literature supplied from the manufacturer, or contact your local International Harvester representative.

WARNING

```

////////////////////////////////////
//
// Before attempting to open or service the pump:
//
// 1. Familiarize yourself with this manual.
// 2. Switch off the engine ignition and remove the key
//    to ensure that the pump will remain inoperative.
// 3. Allow the pump to cool if overheated.
// 4. Vent the pump slowly and cautiously.
// 5. Close the suction and discharge valves.
// 6. Check the temperature before opening any covers,
//    plates, or plugs.
// 7. Drain the pump.
//
////////////////////////////////////

```

Pump Disassembly

Before attempting to service the pump, remove the casing drain plug (34) and drain the pump. Clean and reinstall the drain plug.

To service the wear ring (33), impeller (2), seal assembly (3), or seal plate (31), the pump casing (1) must be separated from the base and intermediate (27).

Remove the suction and discharge lines. Remove the hardware securing the casing to the base. Remove the nuts (30), and use a suitable hoist and sling to separate the pump casing and gasket (32) from the seal plate (31) and intermediate (27).

Tie and tag any leveling shims used under the casing feet to ease reassembly.

WARNING

```

////////////////////////////////////
//                               //
// Use lifting and moving equipment in good repair and with //
// adequate capacity to prevent injuries to personnel or //
// damage to equipment. //
//                               //
////////////////////////////////////

```

Inspect the wear ring (33) for excessive wear or scoring. The wear ring is secured in the pump casing by a press fit, and if replacement is required, use a suitable puller to remove it.

Impeller Removal

To remove the impeller (2), remove the impeller capscrew, lockwasher, and flat washer (40, 41 and 42). Insert a 1/2 inch diameter steel rod between the impeller vanes and carefully turn the rod in a counter-clockwise direction (when facing the impeller). **Be careful** not to damage the impeller vanes.

After the impeller breaks loose, remove the bar and unscrew the impeller. Use caution when removing the impeller; tension on the seal spring will be released as the impeller is removed. Remove the impeller adjusting shims (15). Tie and tag the shims or measure and record their thickness for ease of reassembly.

Seal Removal And Disassembly

Remove the spring, shaft sleeve (28), retainer and bellows, and rotating element.

Remove the round head machine screws (9) and slide the seal plate and stationary element off the shaft as a unit. Press the stationary seal element with O-ring out of the seal plate.

Inspect the wear ring (10) for excessive wear or damage. If replacement is required, use a suitable puller to remove it from the seal plate.

Separating Intermediate From Engine

To service the drive assembly, shaft (22) or bearing (11), the intermediate (27) must be separated from the engine.

Support the intermediate using a suitable hoist and sling, and remove the hardware (23 and 24) securing it to the engine bellhousing. Separate the assemblies by pulling the intermediate straight away from the engine. As the assemblies are separated, the impeller shaft (22) will disengage from the drive plate assembly (20).

It is not necessary to remove the drive plate assembly from the engine flywheel unless the assembly or the pilot bushing (21) must be replaced. To remove the drive plate assembly, disengage the hardware (16 and 17).

Inspect the pilot bushing for excessive wear or damage. If replacement is required, use a suitable puller to remove it from the flywheel.

Shaft And Bearing Removal And Disassembly

When the pump is properly operated and maintained, the shaft and bearing should not require disassembly. Disassemble the shaft and bearing **only** when there is evidence of wear or damage.

CAUTION

Shaft and bearing disassembly in the field is not recommended. These operations should be performed only in a properly-equipped shop by qualified personnel.

After separating the intermediate from the engine, loosen the setscrew (18) and unscrew the bearing retaining nut (25) from the intermediate.

NOTE

- There are no provisions for draining the grease from the intermediate cavity. Place a drip pan under the intermediate before removing the shaft and bearing.

Place a block of wood against the impeller end of the shaft and tap the shaft and assembled bearing from the bearing bore. **Be careful** not to damage the shaft threads.

Remove the inboard bearing retaining ring and press the bearing (11) from the shaft. It is not necessary to remove the outboard bearing retaining ring from the shaft unless replacement is required.

Shaft and Bearing Reassembly And Installation

Clean the intermediate, shaft and all component parts (except the bearing) with a soft cloth soaked in cleaning solvent. Inspect the parts for wear or damage and replace as necessary.

WARNING

```

////////////////////////////////////
//
// Most cleaning solvents are toxic and flammable. Use //
// them only in a well-ventilated area free from excessive //
// heat, sparks, and flame. Read and follow all prec- //
// autions printed on solvent containers. //
//
////////////////////////////////////

```

Inspect the shaft for distortion, nicks or scratches or thread damage on the impeller end. Dress small nicks and burrs with a fine file or emery cloth. Replace the shaft if defective.

Clean the bearing thoroughly in **fresh** cleaning solvent. Dry the bearing with filtered compressed air and coat with light oil.

Rotate the bearing by hand to check for roughness or binding and inspect the bearing balls. If rotation is rough or the bearing balls are discolored, replace the bearing.

CAUTION

Bearings must be kept free of all dirt and foreign material. Failure to do so will greatly shorten bearing life. **DO NOT** spin dry bearings. This may scratch the balls or races and cause premature bearing failure.

The bearing tolerances provide a tight press fit onto the shaft and a snug slip fit into the intermediate. Replace the shaft or intermediate if the proper bearing fit is not achieved.

Pre-pack the bearing by hand (or use a bearing packer if available) with No. 0 lithium base grease until the bearing balls are thoroughly lubricated.

Position the bearing on the shaft with the shielded side toward the impeller end of the shaft. Press the bearing onto the shaft until it seats squarely against the outboard bearing retaining ring.

CAUTION

When installing the bearings onto the shaft, **NEVER** press or hit against the outer race, balls, or ball cage. Press **ONLY** on the inner race.

Install the inboard bearing retaining ring.

Slide the shaft and assembled bearing into the intermediate bore from the drive end until the bearing seats squarely against the bore shoulder.

CAUTION

When installing the shaft and bearings into the bearing bore, push against the outer race. NEVER hit the balls or ball cage.

Screw the bearing retaining nut into the intermediate and check the shaft endplay. Shaft endplay should be between .002 and .010 inch. Adjust the bearing retaining nut to establish the correct endplay, then secure the retaining nut with the setscrew (18).

Lubricate the bearing cavity as indicated in LUBRICATION, Section E.

Securing Intermediate To Engine

Apply a thin coating of 'Never-Seez' lubricant to the inside diameter of the pilot bushing (21) and press it into the flywheel until the backside of the pilot bushing is **just flush** with the backside of the flywheel. Make certain the bushing does not protrude and preload the shaft and bearing.

CAUTION

If the pilot bushing and drive plate are not properly positioned on the shaft, a preload condition could cause excessive wear and/or premature bearing failure.

Secure the drive plate assembly to the flywheel with the hardware (16 and 17).

Slide the shaft splines into the drive plate and secure the intermediate assembly to the engine bellhousing with the hardware (23 and 24).

Seal Installation**(Figures 1 and 2)**

Clean the seal cavity and shaft with a cloth soaked in fresh cleaning solvent.

WARNING

```

////////////////////////////////////
//
// Most cleaning solvents are toxic and flammable. Use //
// them only in a well-ventilated area free from excessive //
// heat, sparks, and flame. Read and follow all prec- //
// autions printed on solvent containers. //
// //
////////////////////////////////////

```

The seal is not normally reused because wear patterns on the finished faces cannot be realigned during reassembly. This could result in premature failure. If necessary to reuse an old seal in an emergency, **carefully** wash all metallic parts in fresh cleaning solvent and allow to dry thoroughly.

Handle the seal parts with extreme care to prevent damage. Be careful not to contaminate precision finished faces; even fingerprints on the faces can shorten seal life. If necessary, clean the faces with a non-oil based solvent and a clean lint free tissue. Wipe **lightly** in a concentric pattern to avoid scratching the faces.

Inspect the seal components for wear, scoring, grooves, and other damage that might cause leakage. Clean and polish the shaft sleeve, or replace it if there are nicks or cuts on either end. If any components are worn, replace the complete seal; **never mix old and new seal parts.**

If a replacement seal is being used, remove it from the container and inspect the precision finished faces to ensure that they are free of any foreign matter.

To ease installation of the seal, lubricate the O-rings and bellows with water or a very **small** amount of oil, and apply a drop of light lubricating oil on the finished faces. Assemble the seal as follows, (see Figure 2).

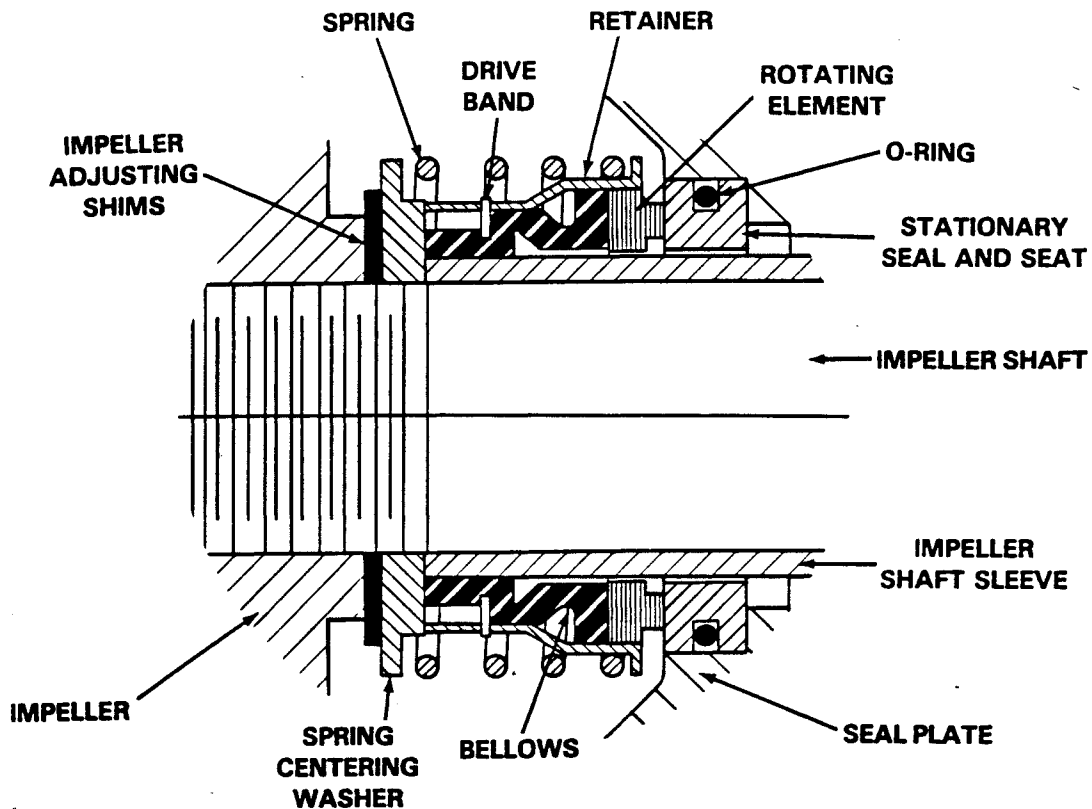

Figure 2. 25271-207 Seal Assembly

CAUTION

This seal is not designed for operation at temperatures above 160° F. Do not use at higher operating temperatures.

Lay the seal plate (31) on a flat surface with the impeller side facing up. If the wear ring (10) was removed, press the replacement ring into the seal plate until it seats squarely against the bore shoulder.

CAUTION

The wear ring **MUST** seat squarely in the seal plate bore or binding and/or excessive wear will result.

Subassemble the O-ring onto the stationary element and use even pressure to press this subassembly into the seal plate until it seats squarely against the shoulder bore. Position the shaft sleeve (28) through the I.D. of the stationary element with the chamfered end down.

Subassemble the rotating element into the retainer and bellows and slide this subassembly over the shaft sleeve until the polished faces contact.

Carefully slide the assembled seal plate, sleeve, and seal over the shaft. Secure the seal plate to the intermediate with the round head machine screws (9). Install the seal spring.

Impeller Installation

Inspect the impeller and replace it if cracked or badly worn. Install the same thickness of impeller adjusting shims (15) as previously removed and screw the impeller onto the shaft until tight.

For maximum pump efficiency, the impeller should be centered within the volute scroll.

To verify the impeller positioning, measure the pump casing and impeller as shown in Figure 3. Use these measurements to calculate the required impeller location (dimension E). Add or remove impeller adjusting shims until dimension E is obtained.

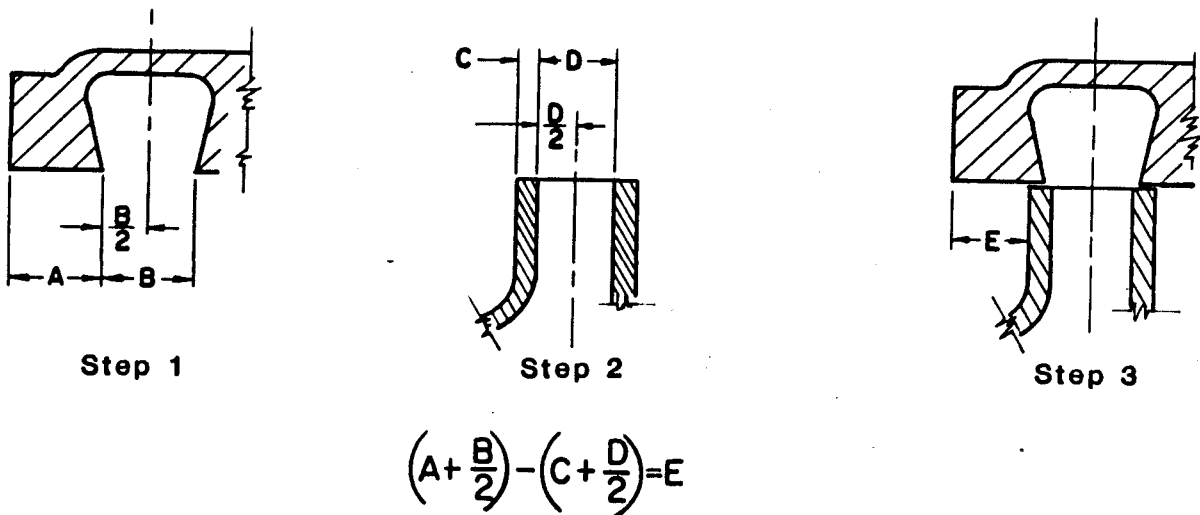

Figure 3. Centering Impeller Within Volute Scroll

NOTE

After the impeller has been properly positioned, check for free rotation. Correct any scraping binding before further reassembly.

When the impeller is properly positioned, secure it with the impeller capscrew, flat washer and lockwasher (40, 41 and 42).

Pump Reassembly

If removed at disassembly, press the replacement wear ring (33) into the casing until it seats squarely against the shoulder bore.

CAUTION

The wear ring **MUST** seat squarely in the casing bore or binding and/or excessive wear will result.

Install the casing gasket (32) and secure the casing to the seal plate and intermediate with the hardware (30). Reinstall any leveling shims used under the casing mounting feet and secure the casing to the base.

Final Pump Reassembly

Be sure the pump and engine are securely mounted to the base.

Install the suction and discharge lines and open all valves. Make certain that all piping connections are tight, properly supported and secure.

Be sure the pump and intermediate have been properly lubricated (see LUBRICATION).

Fill the pump casing with clean liquid. Reinstall the fill plug and tighten it.

Refer to **OPERATION**, Section C, before putting the pump back into service.

LUBRICATION

Seal Assembly

The seal assembly is lubricated by the medium being pumped, and no additional lubrication is required.

Bearings

The intermediate was fully lubricated when shipped from the factory. Under normal conditions, add three shots of No. 0 lithium base grease from a grease gun through the grease fitting (13) after each 250 hours of operation or once each month, whichever comes first. **Do not** over-lubricate. Over-lubrication can cause the bearings to over-heat, resulting in premature bearing failure.

CAUTION

If grease is forced out around the shaft as new grease is added, the bearing cavity is full and should be disassembled and cleaned immediately.

There are no provisions in the bearing cavity to drain or flush the lubricant. The pump and intermediate must be disassembled to completely clean and maintain this cavity.

Under normal conditions, change the grease after each 5000 hours of operation, or at 12 month intervals, whichever comes first. Change the grease more frequently if the pump is operated continuously or installed in an environment where variable hot and cold temperatures are common.

When lubricating a dry (overhauled) intermediate, fill the cavity through the lubrication fitting with approximately one-third of a pound of grease (approximately one-third full).

For cold weather operation, consult the factory or a lubricant supplier for the recommended grade of lubricant.

Engine

Refer to the literature accompanying the engine or contact your local International Harvester representative for the manufacturer's recommendations.

**For U.S. and International Warranty Information,
Please Visit www.grpumps.com/warranty
or call:
U.S.: 419-755-1280
International: +1-419-755-1352**

**For Canadian Warranty Information,
Please Visit www.grcanada.com/warranty
or call:
519-631-2870**