

INSTALLATION, OPERATION, PARTS LIST,
AND MAINTENANCE MANUAL

A C E



OM-01212-0E01

May 26, 1981

A large, stylized outline of a centrifugal pump, showing the main body, inlet and outlet ports, and a central shaft area. The text is overlaid on this outline.

***Engine Driven
Self Priming
Centrifugal Pump
Model 04B3-(UD282)***

THE GORMAN-RUPP COMPANY • MANSFIELD, OHIO
GORMAN-RUPP OF CANADA LIMITED • ST. THOMAS, ONTARIO, CANADA

Printed in U.S.A.

Copyright by the Gorman-Rupp Company



This Installation, Operation, and Maintenance Manual is designed to help you get the best performance and longest life from your Gorman-Rupp pump.

This pump is an O Series, enclosed impeller, self-priming centrifugal model with straight-in suction without a suction check valve. This pump is suitable for pumping liquids which do not contain large solids. For specific service, consult your Gorman-Rupp distributor or the Gorman-Rupp Company.

If there are any questions regarding the pump which are not covered in this manual or in other literature accompanying the unit, please contact your Gorman-Rupp distributor, or write:

| | | |
|-------------------------|----|-------------------------------|
| The Gorman-Rupp Company | or | Gorman-Rupp of Canada Limited |
| P. O. Box 1217 | | 70 Burwell Road |
| Mansfield, Ohio 44902 | | St. Thomas, Ontario N5P 3R7 |

For information or technical assistance on the engine drive, contact the engine manufacturer's local dealer or representative.

The following are used to alert maintenance personnel to procedures which require special attention, to those which could damage equipment, and to those which could be dangerous to personnel:

NOTE

Instructions to aid in installation, operation, or maintenance or which clarify a procedure.

CAUTION

Instructions which must be followed to avoid causing damage to the product or other equipment incidental to the installation. These describe the procedure required and the damage which could result from failure to follow the procedure.

WARNING

Instructions which must be followed to avoid causing injury or death to personnel. These describe the procedure required and the injury which could result from failure to follow the procedure.

TABLE OF CONTENTS

| | |
|------------------------|-----------|
| WARNINGS | Section A |
| INSTALLATION | Section B |
| OPERATION | Section C |
| TROUBLESHOOTING | Section D |
| MAINTENANCE AND REPAIR | Section E |
| WARRANTY | |

WARNING

THESE WARNINGS APPLY TO O SERIES ENGINE DRIVEN PUMPS. REFER TO THE MANUAL ACCOMPANYING THE ENGINE BEFORE ATTEMPTING TO START THE ENGINE.

Before attempting to open or service the pump:

1. Familiarize yourself with this manual.
2. Disconnect the engine ignition to ensure that the pump will remain inoperative.
3. Allow the pump to cool if overheated.
4. Vent the pump slowly and cautiously.
5. Close the suction and discharge valves in the piping lines.
6. Check the temperature before opening any covers, plates, or plugs.
7. Drain the pump.

This pump has been designed to handle specific liquids. Do not attempt to pump any liquids for which this pump has not been designed.

Make certain that the pump and engine are securely attached before attempting to operate the pump.

Do not operate the pump against a closed discharge valve for long periods of time. This could bring the liquid to a boil, build pressure, and cause the pump to rupture or explode.



Overheated pumps can cause severe burns and injury. If overheating of the pump casing occurs:

1. Stop the pump immediately.
2. Allow the pump to cool.
3. Refer to instructions in this manual before restarting the pump.

Do not remove plates, covers, gauges, pipe plugs, or fittings from an overheated pump. Vapor pressure within the pump can cause parts being disengaged to be ejected with great force. Allow the pump to cool before servicing.

Do not operate an internal combustion engine in an explosive atmosphere. When operating internal combustion engines in an enclosed area, make certain that exhaust fumes are piped to the outside. These fumes contain carbon monoxide, a deadly gas that is colorless, tasteless, and odorless.

Fuel used by internal combustion engines presents an extreme explosion and fire hazard. Make certain that all fuel lines are securely connected and free of leaks. Never refuel a hot or running engine. Avoid overfilling the fuel tank. Always use the correct type of fuel.

Never tamper with the governor to gain more power. The governor establishes safe operating limits that should not be exceeded.

INSTALLATION

Since pump installations vary, this section is intended only to summarize recommended installation practice. If there are any questions concerning a specific installation, contact your Gorman-Rupp distributor or the Gorman-Rupp Company.

PREINSTALLATION INSPECTION

The pump assembly was inspected and tested before it was shipped from the factory. Before installation, inspect the pump for damage which may have occurred during shipment.

- a. Check the pump assembly for cracks, dents, damaged threads, and other obvious damage.
- b. Check for and tighten loose bolts, nuts, capscrews, and other attaching hardware. Since gaskets tend to shrink after drying, check for and tighten loose nuts and capscrews securing mating surfaces.
- c. Carefully read all tags, decals, and markings on the pump assembly, and perform all duties indicated. Note the direction of rotation indicated on the pump. Check that the pump shaft rotates in the required direction.

CAUTION

Only operate this pump in the direction indicated by the arrow on the pump body and on the accompanying decal. Otherwise, the impeller could become loosened from the shaft and seriously damage the pump.

- d. Check all lubricant levels and lubricate as necessary. Refer to the MAINTENANCE AND REPAIR section of this manual.

POSITIONING THE PUMP

Mounting

Locate the pump in an accessible place as close as practical to the liquid being pumped. Level mounting is essential for proper operation. It may be necessary to support or shim the pump for level operation.

Lifting

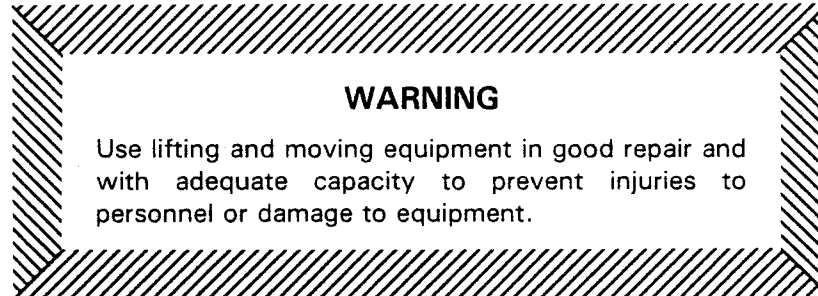

Make sure that hoists and other lifting equipment are of sufficient capacity to safely handle the pump assembly. If chains or cables are used in lifting, make certain that they are positioned so that they will not damage the pump, and so that the load will be balanced.

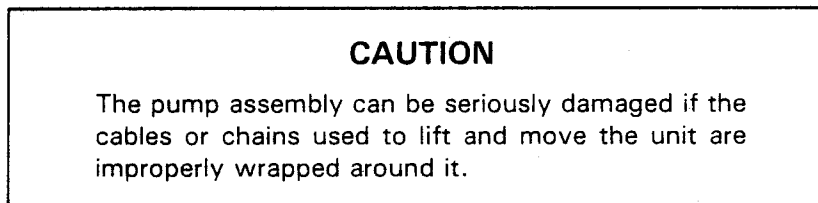

SUCTION AND DISCHARGE PIPING

Materials

Either pipe or hose may be used for suction and discharge lines, but hose used in suction lines must be the rigid-wall, reinforced type to prevent collapse under suction. Using pipe couplings in suction lines is not recommended.

Line Configuration

Keep suction and discharge lines as straight as possible to minimize friction losses. Make minimum use of elbows and fittings, which substantially increase friction loss. If elbows are necessary, use the long-radius type to minimize friction loss.

Connections to Pump

Never pull a pipe line into place by tightening the flange bolts. The connection flange must be aligned exactly with the pump port. Lines near the pump must be independently supported to avoid strain on the pump which could cause serious vibration, decreased bearing life, and increased shaft and seal wear. Hose-type lines should have supports strong enough to secure the line when it is filled with liquid and under pressure.

Gauges

Most pumps are drilled and tapped for installing discharge pressure and vacuum suction gauges. If these gauges are desired for pumps that are not tapped, drill and tap the suction and discharge lines close to the pump before installing the lines.

SUCTION LINES

To avoid air pockets which could affect pump priming, the suction line must be as short and direct as possible. When operation involves a suction lift, the line must always slope upward to the pump from the source of the liquid being pumped; if the line slopes down to the pump at any point along the suction run, air pockets will be created.

Fittings

Suction lines should be the same size as the pump inlet. If reducers are used in suction lines, they should be the eccentric type, and should be installed with the flat part of the reducers uppermost to avoid creating air pockets. Valves are not normally used in suction lines, but if a valve is used, install it with the stem down or to either side to avoid air pockets.

Strainers

This pump is designed primarily for liquids which do not need straining, and a strainer is not usually furnished with the pump when it is shipped from the factory. If a strainer is furnished with the pump, however, be certain to use it. Any entrained solids which pass through a strainer furnished with the pump will also pass through the pump itself.

If a strainer is not furnished with the pump, but is installed by the pump user, make certain that the total area of the openings in the strainer is at least three or four times the cross section of the suction line, and that the openings will not permit passage of solids larger than the solids handling capability of the pump.

Sealing

Since even a slight leak will affect priming, head, and capacity, especially when operating with a high suction lift, all connections in the suction line should be sealed with pipe dope to ensure an airtight seal. In volatile and/or corrosive service, the pipe dope should be compatible with the liquid being pumped.

Suction Lines In Sumps

If a single suction line is installed in a sump, it should be positioned away from the wall of the sump at a distance equal to one and one-half times the diameter of the suction line.

If there is a liquid flow from an open pipe into the sump, the flow should be kept away from the suction inlet because the inflow will carry air down into the sump, and air entering the suction line will reduce pump efficiency.

If it is necessary to position inflow close to the suction inlet, install a baffle between the inflow and the suction inlet at a distance equal to one and one-half times the diameter of the suction line. The baffle will allow entrained air to escape from the liquid before it is drawn into the suction inlet.

If two suction lines are installed in a single sump, the flow paths may interact, reducing the efficiency of one or both pumps. To avoid this, position the suction inlets so that they are separated by a distance equal to three times the diameter of the suction line.

Suction Line Positioning

The depth of submergence of the suction line is critical to efficient pump operation. Figure 1 shows recommended minimum submergence vs. velocity.

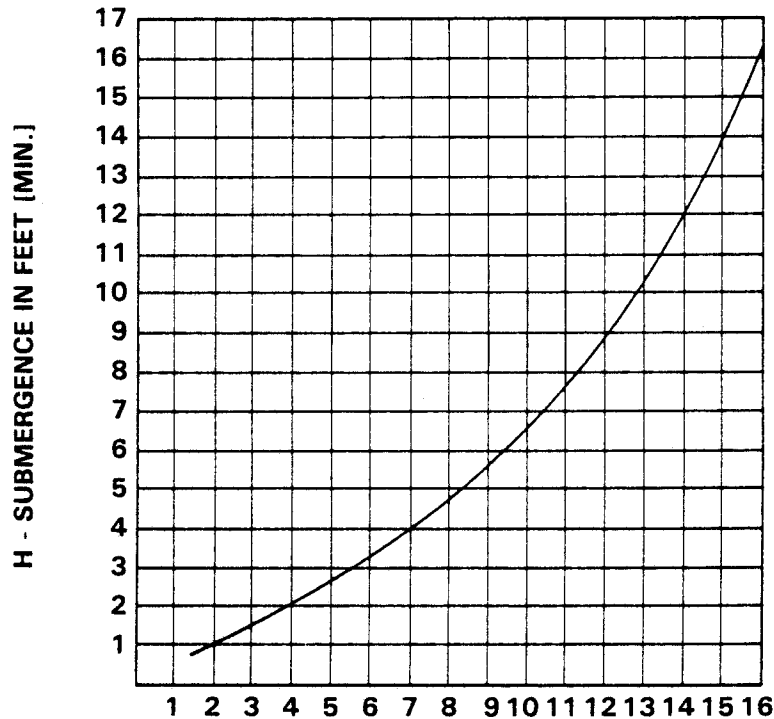

$$\text{VELOCITY IN FEET PER SEC.} = \frac{\text{QUAN. [G.P.M.] x .321}}{\text{AREA}} \text{ OR } \frac{\text{G.P.M. x .4085}}{D^2}$$

Figure 1. Recommended Minimum Suction Line Submergence Vs. Velocity

DISCHARGE LINES

Do not terminate the discharge line at a level lower than that of the liquid being pumped unless a siphon breaker is used in the line. Otherwise, a siphoning action causing damage to the pump could result.

Valves

If a throttling valve is desired in the discharge line, use a valve as large as the largest pipe in the line to minimize friction losses. Never install a throttling valve in a suction line.

A check valve in the discharge line is normally recommended, but is not necessary in low discharge head applications.

With high discharge heads, install a throttling valve and a check valve in the discharge line to protect the pump from excessive shock pressure and reverse rotation when it is stopped.

Bypass Lines

If it is necessary to permit the escape of air to atmosphere in initial priming or during the repriming cycle, install a bypass line — sized so that it will not affect pump discharge capacity — between the pump and the discharge check valve. Since this pump does not use a suction check valve, the discharge end of the bypass line must be submerged in the liquid being pumped in order to maintain suction.

OPERATION

WARNING

Do not attempt to pump any liquids for which this pump has not been designed.

PRIMING

Install the pump and piping as described in INSTALLATION. Make sure that the piping connections are tight, and that the pump is securely mounted. Check that the pump is properly lubricated (see LUBRICATION in MAINTENANCE AND REPAIR).

Although this pump is self-priming, it should never be operated unless the volute is filled with liquid.

CAUTION

Never operate this pump unless the volute is filled with liquid. The pump will not prime when dry. Extended operation of a dry pump will destroy the seal assembly.

Fill the pump with liquid:

1. When the pump is being put into service for the first time.
2. When the pump has not been used for a considerable length of time.
3. When the liquid in the volute housing has evaporated.

When the volute housing is full, the pump will prime and reprime as necessary.

To fill the pump, remove the fill plug at the top of the volute housing, and add clean liquid. Be certain to reinstall the fill plug before operating the pump.

WARNING

After filling the volute housing, do not attempt to operate the pump unless the fill plug and all connecting piping is securely installed. Otherwise, liquid in the pump forced out under pressure could cause injury to personnel.

STARTING

Rotation

The correct direction of pump rotation is indicated by an arrow on the pump body, and on the accompanying decal. If the pump is operated in the wrong direction, the impeller could become loosened from the shaft and seriously damage the pump.

CAUTION

Only operate this pump in the direction indicated by the arrow on the pump body and on the accompanying decal. Otherwise, the impeller could become loosened from the shaft and seriously damage the pump.

Consult the operating manual furnished with the engine before attempting to start the engine.

Lines With a Bypass

Since this pump does not have a suction check valve, the discharge end of the bypass line must be submerged in order to maintain suction.

Close the throttling valve in the discharge line, and open the shutoff valve in the bypass line so that the pump will not have to prime against the weight of the liquid in the discharge line. Start the engine. When the pump has been primed and liquid is flowing steadily through the bypass line, close the bypass shutoff valve and open the discharge throttling valve.

Lines Without a Bypass

Open all valves in the discharge line and start the engine. Priming is indicated by a positive reading on the discharge pressure gauge or by quieter operation. The pump may not prime immediately because the suction line must first fill with liquid. If the pump fails to prime within five minutes, stop it and check the suction line for leaks.

After the pump has been primed, partially close the discharge line throttling valve in order to fill the line slowly and guard against excessive shock pressure which could damage pipe ends, gaskets, sprinkler heads, and any other fixtures connected to the line. When the discharge line is completely filled, adjust the throttling valve to the required discharge flow rate.

Leakage

No leakage should be visible at pump mating surfaces, or at pump connections or fittings. Keep all line connections and fittings tight to maintain maximum pump efficiency.

Overheating

Overheating can occur if the valves in the suction or discharge lines are closed. Operating against closed valves could bring the liquid to a boil, build pressure, and cause the pump to rupture or explode. If overheating occurs, stop the pump and allow it to cool before servicing it. Refill the volute casing with cool liquid.

WARNING

Do not remove plates, covers, gauges, pipe plugs, or fittings from an overheated pump. Vapor pressure within the pump can cause parts being disengaged to be ejected with great force. Allow the pump to cool before servicing.

Strainer Check

If a suction strainer has been shipped with the pump or installed by the user, check the strainer regularly, and clean it as necessary. The strainer should also be checked if pump flow rate begins to drop.

Pump Vacuum Check

With the pump inoperative, install a vacuum gauge on the suction side of the pump, using pipe dope on the threads. Block the suction line and start the pump. At operating speed the pump should pull a vacuum of 20 inches or more of mercury. If it does not, check for air leaks in the seal or gasket.

Open the suction line, and read the vacuum gauge with the pump primed and at operating speed. Shut off the pump, and read the gauge again to determine if the vacuum remains at the maximum developed by the pump. If the vacuum falls off rapidly, an air leak exists; check to make certain that the air leak is not from the vacuum gauge connection.

Stopping

After stopping the pump, disconnect the engine ignition to ensure that the pump will remain inoperative.

In below-freezing conditions, a stopped pump should be drained, and any solids cleaned out by flushing with a hose, to prevent damage from freezing. After draining and flushing, operate the pump for approximately one minute to remove any remaining liquid that could freeze pump rotating parts.

In above-freezing conditions, a pump which will be idle for more than a few hours, or which has been pumping liquids containing solids, should be drained and flushed thoroughly. Operate the pump during the draining process.

Bearing Temperature Check

Bearings normally run at higher than ambient temperatures because of heat generated by friction. Temperatures up to 160°F are considered normal for bearings, and they can operate safely to at least 180°F.

Checking bearing temperatures by hand is inaccurate. Bearing temperatures can be measured accurately by placing a contact-type thermometer against the housing. Record this temperature for future reference.

A sudden increase in bearing temperatures is a warning that the bearings are at the point of failing to operate properly. Make certain that the bearing lubricant is of the proper viscosity and at the correct level (see LUBRICATION in MAINTENANCE AND REPAIR). Bearing overheating can also be caused by shaft misalignment and/or excessive vibration.

When pumps are first started, the bearings may seem to run at temperatures above normal. Continued operation should bring the temperatures down to normal levels.

TROUBLESHOOTING

WARNING

Before attempting to open or service the pump:

1. Consult pump service manual.
2. Disconnect the power source to ensure that the pump will remain inoperative.
3. Allow pump to cool if overheated.
4. Close suction and discharge valves.
5. Drain pump.

| Trouble | Possible Cause | Probable Remedy |
|---|--|---|
| PUMP FAILS TO PRIME | <p>Air leak in suction line.</p> <p>Lining of suction hose collapsed.</p> <p>Leaking or worn seal or pump gasket.</p> <p>Suction lift or discharge head too high.</p> <p>Strainer clogged.</p> | <p>Correct leak.</p> <p>Replace suction hose.</p> <p>Check pump vacuum. Replace leaking or worn seal or gasket.</p> <p>Check piping installation and install bypass line if needed. See INSTALLATION.</p> <p>Check strainer and clean if necessary.</p> |
| PUMP STOPS OR FAILS TO DELIVER RATED FLOW OR PRESSURE | <p>Air leak in suction line.</p> <p>Suction intake not submerged at proper level or sump too small.</p> <p>Lining of suction hose collapsed.</p> <p>Impeller or other wearing parts worn or damaged.</p> <p>Impeller clogged.</p> <p>Pump speed too slow.</p> <p>Discharge head too high.</p> <p>Suction lift too high.</p> <p>Strainer clogged.</p> | <p>Correct leak.</p> <p>Check installation and correct as needed. Check submergence chart (Section B, page 4).</p> <p>Replace suction hose.</p> <p>Replace worn or damaged parts. Check impeller clearance.</p> <p>Free impeller of debris.</p> <p>Check engine output.</p> <p>Install bypass line.</p> <p>Reduce suction lift.</p> <p>Check strainer and clean if necessary.</p> |



| Trouble | Possible Cause | Probable Remedy |
|--|---|---|
| PUMP STOPS OR FAILS TO DELIVER RATED FLOW OR PRESSURE (cont) | <p>Leaking or worn seal or pump gaskets.</p> <p>Suction strainer clogged.</p> | <p>Check pump vacuum. Replace leaking or worn seal or pump gaskets.</p> <p>Check suction strainer.</p> |
| PUMP REQUIRES TOO MUCH POWER | <p>Pump speed too high.</p> <p>Discharge head too low.</p> <p>Liquid solution too thick.</p> | <p>Check engine output; check that any couplings are correctly sized.</p> <p>Adjust discharge valve.</p> <p>Dilute if possible.</p> |
| PUMP CLOGS FREQUENTLY | <p>Discharge flow too slow.</p> | <p>Open discharge valve fully to increase flow rate, and run engine at maximum governed speed.</p> |
| EXCESSIVE NOISE | <p>Cavitation in pump.</p> <p>Pumping entrained air.</p> <p>Pump or drive not securely mounted.</p> <p>Impeller clogged or damaged.</p> | <p>Reduce suction lift and/or friction losses in suction line.</p> <p>Locate and eliminate source of air bubble.</p> <p>Secure mounting hardware.</p> <p>Clean out debris; replace damaged parts.</p> |
| BEARINGS RUN TOO HOT | <p>Bearing temperature is high, but within limits.</p> <p>Low or incorrect lubricant.</p> <p>Suction and discharge lines not properly supported.</p> <p>Drive misaligned.</p> | <p>Check bearing temperature frequently to monitor any increase.</p> <p>Check for proper type and level of lubricant.</p> <p>Check piping installation for proper support.</p> <p>Align drive properly.</p> |

Engine Driven Self-Priming Centrifugal Pump Model 04B3-(UD282)

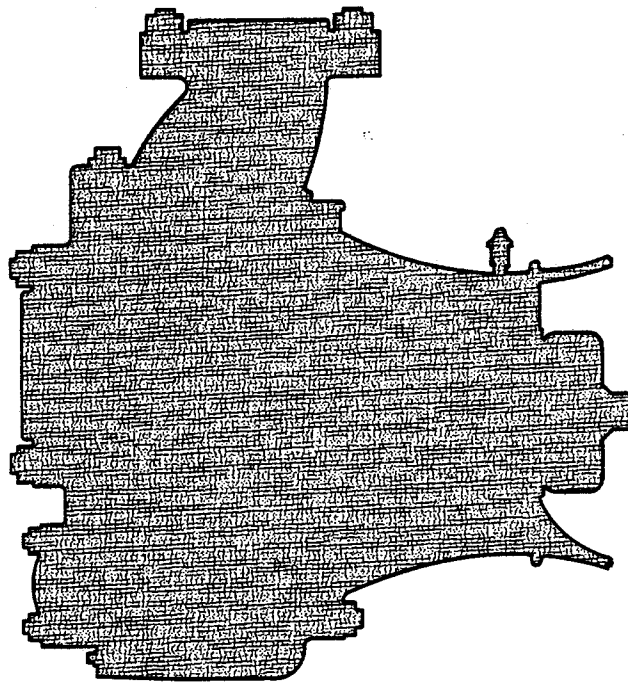

The only moving parts of this pump are the impeller, seal rotating elements, and the shaft. The wear rings, impeller, and seal, which receive the most wear, are easily accessible and can be replaced without disturbing the piping. Maintenance and replacement of these three parts will maintain the peak operating efficiency of the pump.

SECTIONAL DRAWING

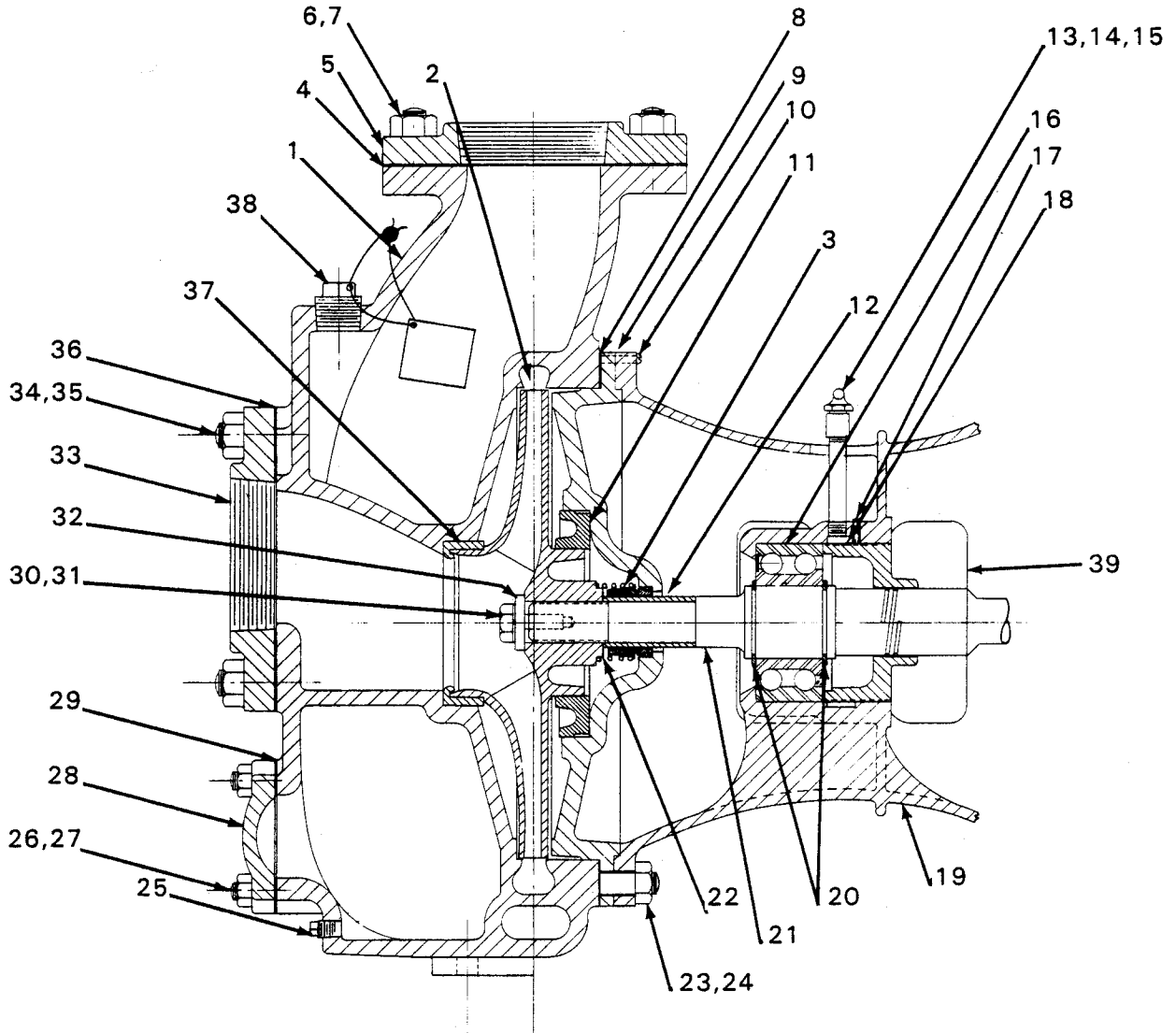

Figure 1. Pump Model 04B3-(UD282)



PARTS LIST
PUMP MODEL 04B3-(UD282)
(From S/N 393339 up)

| ITEM NO. | PART NAME | PART NUMBER | MATL CODE | QTY |
|------------|-----------------------------|-------------|-----------|-----|
| 1 | VOLUTE HOUSING | 4820-C | 10010 | 1 |
| 2 | ★IMPELLER | 4803-F | 14000 | 1 |
| 3 | ★SEAL ASSEMBLY | 25271-207 | — | 1 |
| 4 | ★DISCHARGE FLANGE GASKET | 1676-GB | 20000 | 1 |
| 5 | DISCHARGE FLANGE | 1756 | 10010 | 1 |
| 6 | STUD | C-1009 | 15991 | 8 |
| 7 | HEX NUT | D-10 | 15991 | 8 |
| 8 | ★VOLUTE HOUSING GASKET | 4820-G | 20000 | 1 |
| 9 | SEAL PLATE | 5792 | 10010 | 1 |
| 10 | ROUND HEAD MACHINE SCREW | X-0404 | 15991 | 2 |
| 11 | ★WEAR RING | 6902 | 10010 | 1 |
| 12 | ★SHAFT SLEEVE | 3428-D | 17030 | 1 |
| 13 | PIPE NIPPLE | T-0410 | 15070 | 1 |
| 14 | PIPE COUPLING | AE-04 | 11990 | 1 |
| 15 | LUBRICATION FITTING | S-191 | — | 1 |
| 16 | ★BALL BEARING | S-1031 | — | 1 |
| 17 | ALLEN HEAD SETSCREW | GA-0403 | 15990 | 1 |
| 18 | BEARING RETAINING NUT | 4329 | 10010 | 1 |
| 19 | INTERMEDIATE | 7765-A | 10010 | 1 |
| 20 | RETAINING RING | S-215 | — | 2 |
| 21 | ★IMPELLER SHAFT | 11233-A | 16040 | 1 |
| 22 | ★IMPELLER SHIM SET | 37-J | 17090 | 1 |
| 23 | STUD | C-1010 | 15991 | 12 |
| 24 | HEX NUT | D-10 | 15991 | 12 |
| 25 | VOLUTE DRAIN PLUG | P-06 | 11990 | 1 |
| 26 | STUD | C-0807 | 15991 | 6 |
| 27 | HEX NUT | D-08 | 15991 | 6 |
| 28 | COVER | 4822 | 10010 | 1 |
| 29 | ★COVER GASKET | 4822-G | 20000 | 1 |
| 30 | IMPELLER LOCKWASHER | AK-10 | 15991 | 1 |
| 31 | IMPELLER CAPSCREW | B-1005 | 15991 | 1 |
| 32 | IMPELLER WASHER | 5718 | 15990 | 1 |
| 33 | SUCTION FLANGE | 1756 | 10010 | 1 |
| 34 | STUD | C-1009 | 15991 | 8 |
| 35 | HEX NUT | D-10 | 15991 | 8 |
| 36 | ★SUCTION FLANGE GASKET | 1676-GB | 20000 | 1 |
| 37 | ★WEAR RING | 3765-A | 10010 | 1 |
| 38 | FILL PLUG ASSEMBLY | 48271-065 | — | 1 |
| 39 | INTERMEDIATE GUARD ASSEMBLY | 42381-504 | — | 2 |
| NOT SHOWN: | | | | |
| | NAME PLATE | 2613-C | 13990 | 1 |

★ INDICATES PARTS RECOMMENDED FOR STOCK
Above Serial Numbers Do Not Apply To Pumps Made In Canada.

CANADIAN SERIAL NO. AND UP

PUMP AND SEAL DISASSEMBLY AND REASSEMBLY

This pump requires little service due to its rugged, minimum-maintenance design. If it becomes necessary to inspect or replace components in and adjacent to the rotating assembly, however, follow these instructions, which are keyed to the sectional view (see figure 1) and the accompanying parts list.

Pump Disassembly

WARNING

Before attempting to open or service the pump:

1. Familiarize yourself with this manual.
2. Disconnect the engine ignition to ensure that the pump will remain inoperative.
3. Allow the pump to cool if overheated.
4. Vent the pump slowly and cautiously.
5. Close the suction and discharge valves.
6. Check the temperature before opening any covers, plates, or plugs.
7. Drain the pump.

Disconnect the engine ignition, making certain that it will remain inoperative while the pump is being serviced, and close all connecting valves.

Remove the volute housing drain plug (25) to drain the pump. Clean and reinstall the plug after the pump has been drained.

For access to the impeller (2) and seal assembly (3), the pump must be opened at the point where the volute housing (1) and the seal plate (9) are joined to the intermediate (19). Remove the hex nuts (24) securing these assemblies and separate the assemblies.

To remove the impeller, immobilize it by inserting a pry bar or other suitable device between the vanes, and disengage the impeller capscrew (31) and remove washers (30 and 32). Loosen the impeller by prying it in the direction of pump rotation; use caution not to damage the impeller vanes. Use caution when unscrewing the impeller from the shaft; tension on the seal spring will be released at the impeller is removed.

Remove the impeller adjusting shims (22). For ease of reassembly, tag and tie the shims, or measure and record their thickness.

Seal Disassembly

Remove the seal spring. Using a stiff wire with a hooked end if necessary, remove the remainder of the seal components and the shaft sleeve (12).

Clean the seal cavity and the shaft with a soft cloth soaked in cleaning solvent.

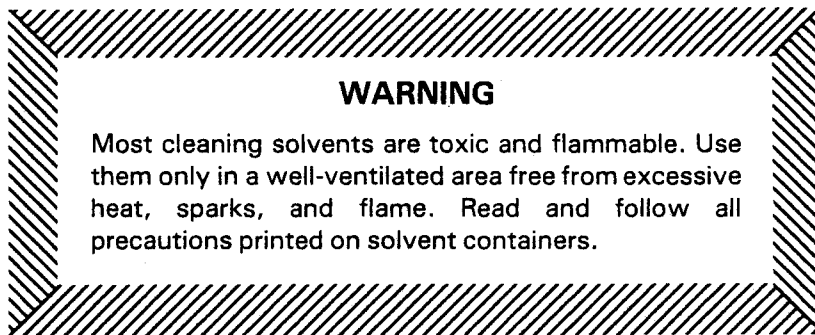
**Seal Reassembly**

The seal is not normally reused because of the high polish on its lapped faces, but if it is necessary to reuse the old seal, wash all metallic parts in cleaning solvent and dry thoroughly.

Inspect the seal components for wear, scoring, grooves, and other damage that might cause leakage. If any components are worn, replace the complete seal; never mix old and new seal parts.

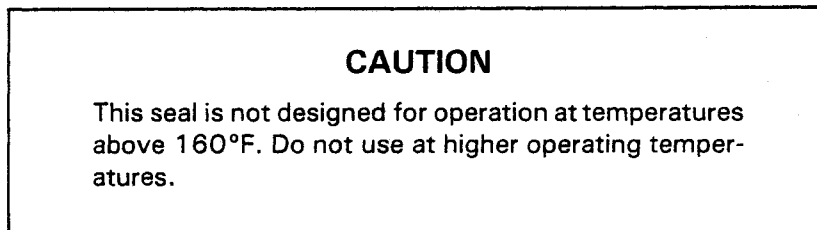

See figure 2 for the correct order of installation of seal components.

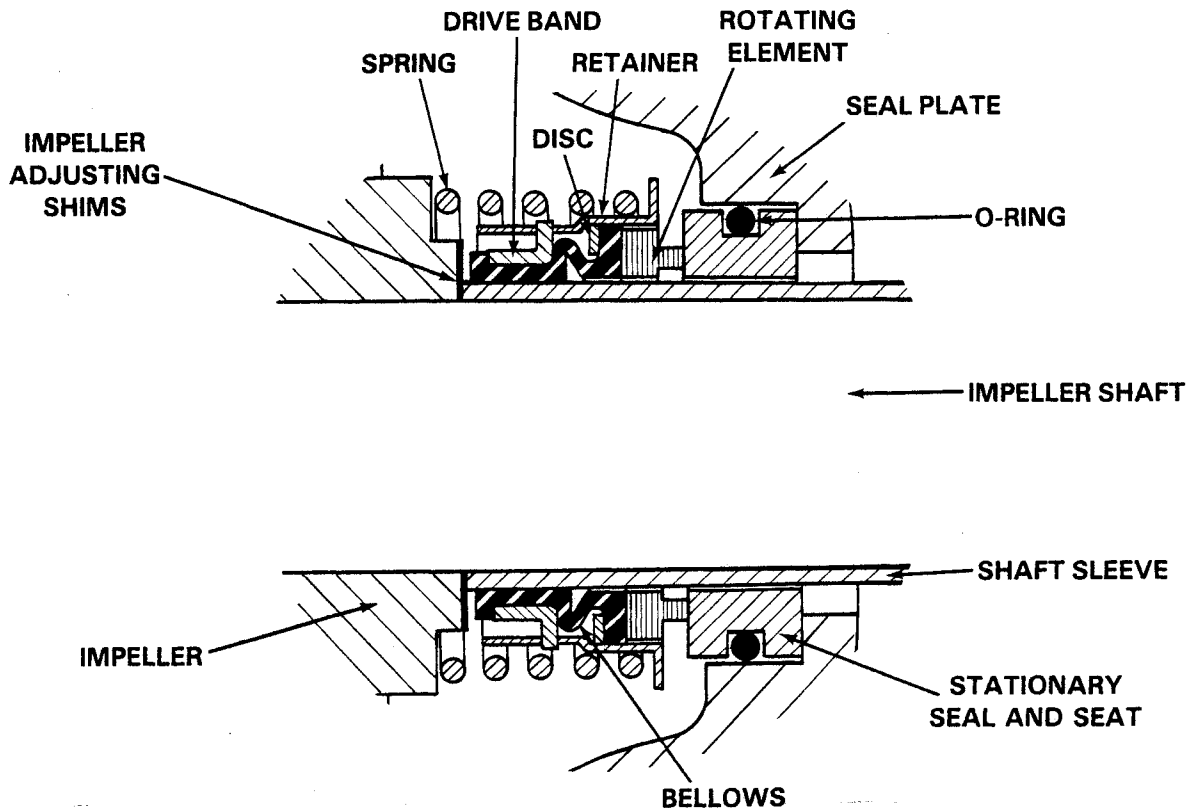

Figure 2. 25271-207 Seal Assembly

Clean and polish the shaft sleeve, or replace it if there are nicks or cuts on the end; reinstall the shaft sleeve.

Place a drop of light lubricating oil on the lapped faces of the seal and lubricate the stationary seat O-rings with soft grease or oil; install the O-ring in the stationary seat.

Install the stationary seat, and rotating element. Lubricate the bellows with soft grease or oil, and install the bellows assembly. Install the seal spring, making certain that all components of the seal are seated squarely.

Pump Reassembly

For maximum pump efficiency, the impeller must be centered with the volute scroll.

Install the impeller adjusting shims. If the same number and thickness of impeller shims are reinstalled as were removed, the impeller should be centered with the volute scroll.

Inspect the wear rings (11 and 37), and replace them if badly worn.

Inspect the impeller, and replace it if cracked or badly worn. Install and block the impeller, and turn the shaft until the impeller is secure. Install the impeller washers; install and tighten the impeller capscrew.

Replace the volute housing gasket (8) and secure the volute housing and seal plate to the intermediate.

Turn the shaft to check that the impeller rotates freely. If it does not, remove additional impeller shims until the impeller rotates freely when the pump is completely assembled.

Remove the fill plug (38), and fill the volute with clean liquid. Clean and reinstall the fill plug. Make certain that the fill plug and all piping are securely tightened before starting the pump.

LUBRICATION

Seal Assembly

The seal assembly is lubricated by the medium being pumped.

Bearings

When shipped from the factory, this pump contained sufficient grease to lubricate the bearings for approximately 5,000 operating hours. Do not lubricate sooner than required. When additional grease is required, remove the lubrication fitting (15), and fill the cavity with No. 0 pressure gun grease until the cavity is approximately one-third full, or just below the shaft. Clean and reinstall the lubrication fitting.

ENGINE SEPARATION

Engine Disassembly

Disengage the hex head capscrews (7) and lockwashers (8) securing the intermediate (2) to the engine bell housing, and slide the engine off the shaft.

To remove the drive plate assembly (6), disengage the hex head capscrews (3) and lockwashers (4) securing the assembly to the engine flywheel. Remove the drive plate assembly, and the pilot bushing (5), which is seated in the flywheel.

Engine Reassembly

Inspect the drive plate assembly and pilot bushing, and replace as necessary. Clean the shaft, the hub of the drive plate assembly, and the pilot bushing with a soft cloth soaked in cleaning solvent.

Apply Never-Seez, or equivalent, lubricant to the inside diameter of the pilot bushing. Seat the pilot bushing in the flywheel so that there is a clearance of approximately 1/8 inch between the pump side of the pilot bushing and the pump end of the flywheel adapter.

Reinstall the drive plate assembly on the engine flywheel, slide the engine on the shaft, and secure the engine bell housing to the intermediate.

CROSS SECTIONAL DRAWING

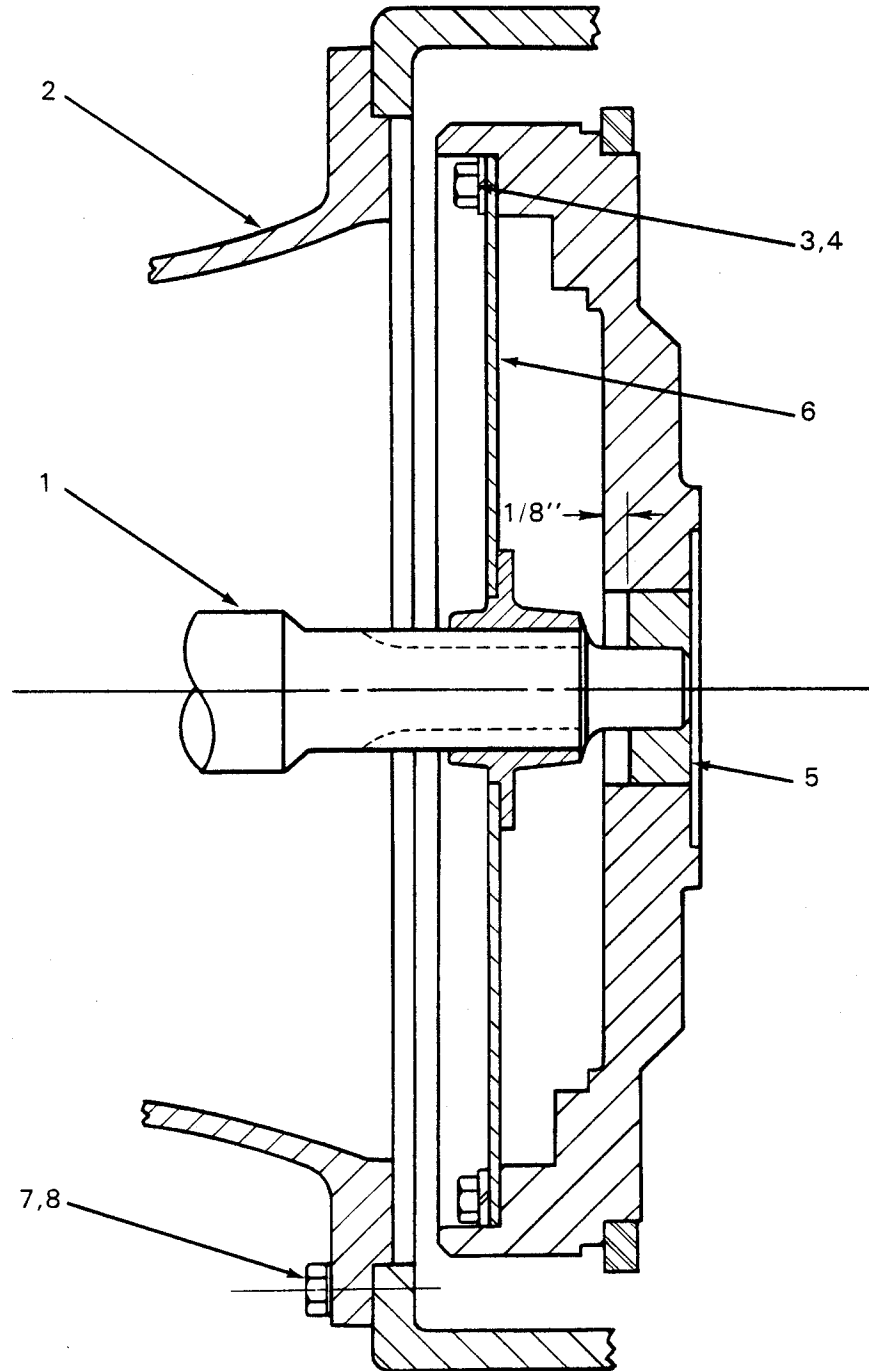

Figure 3. Pump to Engine Installation



PARTS LIST

PUMP MODEL 04B3-(UD282)

Drive Plate Assembly

| ITEM NO. | PART NAME | PART NUMBER | MATERIAL CODE | NUMBER REQ |
|----------|--------------------|-------------|---------------|------------|
| 1 | IMPELLER SHAFT | 11233-A | 16040 | 1 |
| 2 | INTERMEDIATE | 7765-A | 10010 | 1 |
| 3 | HEX HEAD CAPSCREWS | B-0603 | 15991 | 8 |
| 4 | LOCKWASHER | J-06 | 15991 | 8 |
| 5 | PILOT BUSHING | 9208 | 15010 | 1 |
| 6 | DRIVE PLATE | 2194-C | 24020 | 1 |
| 7 | HEX HEAD CAPSCREWS | B-0605 | 15991 | 12 |
| 8 | LOCKWASHER | J-06 | 15991 | 12 |

**For U.S. and International Warranty Information,
Please Visit www.grpumps.com/warranty
or call:
U.S.: 419-755-1280
International: +1-419-755-1352**

**For Canadian Warranty Information,
Please Visit www.grcanada.com/warranty
or call:
519-631-2870**