

**INSTALLATION, OPERATION,
AND MAINTENANCE MANUAL**
WITH PARTS LIST



0 SERIES PUMP

MODEL
03H1-GR

GORMAN-RUPP PUMPS

www.grpumps.com

Register your new
Gorman-Rupp pump online at
www.grpumps.com

Valid serial number and e-mail address required.

RECORD YOUR PUMP MODEL AND SERIAL NUMBER

Please record your pump model and serial number in the spaces provided below. Your Gorman-Rupp distributor needs this information when you require parts or service.

Pump Model: _____

Serial Number: _____

TABLE OF CONTENTS

INTRODUCTION	PAGE I – 1
SAFETY - SECTION A	PAGE A – 1
INSTALLATION – SECTION B	PAGE B – 1
Pump Dimensions	PAGE B – 1
PREINSTALLATION INSPECTION	PAGE B – 2
VEHICLE REQUIREMENTS	PAGE B – 2
Tank Preparation	PAGE B – 2
POSITIONING PUMP	PAGE B – 2
Lifting	PAGE B – 2
ALIGNMENT	PAGE B – 3
SUCTION AND DISCHARGE PIPING	PAGE B – 4
Piping	PAGE B – 5
Sealing	PAGE B – 6
Valves	PAGE B – 6
Siphoning	PAGE B – 7
Eductors	PAGE B – 7
OPERATION – SECTION C	PAGE C – 1
PRIMING	PAGE C – 1
GROUNDING	PAGE C – 1
STARTING	PAGE C – 1
Rotation	PAGE C – 1
Drive	PAGE C – 2
OPERATION	PAGE C – 2
Leakage	PAGE C – 2
Liquid Temperature And Overheating	PAGE C – 2
Strainer Check	PAGE C – 2
Pump Vacuum Check	PAGE C – 3
STOPPING	PAGE C – 3
Cold Weather Preservation	PAGE C – 3
GEARBOX TEMPERATURE CHECK	PAGE C – 3
TROUBLESHOOTING – SECTION D	PAGE D – 1
PUMP MAINTENANCE AND REPAIR - SECTION E	PAGE E – 1
PERFORMANCE CURVE	PAGE E – 1
PARTS LISTS:	
Pump Model	PAGE E – 3
Gearbox Assembly	PAGE E – 5
PUMP AND SEAL DISASSEMBLY AND REASSEMBLY	PAGE E – 6
Removing Pump and Gearbox	PAGE E – 6
Pump Casing and Wear Ring Removal	PAGE E – 7
Impeller Removal	PAGE E – 7
Seal Removal and Disassembly	PAGE E – 7

TABLE OF CONTENTS
(continued)

PUMP AND SEAL REASSEMBLY	PAGE E – 7
Seal Reassembly and Installation	PAGE E – 7
Impeller Installation	PAGE E – 9
Pump Casing and Wear Ring Installation	PAGE E – 9
Installing Pump and Gearbox	PAGE E – 10
GEARBOX DISASSEMBLY	PAGE E – 10
GEARBOX REASSEMBLY	PAGE E – 11
LUBRICATION	PAGE E – 12
Seal Assembly	PAGE E – 12
Gearbox	PAGE E – 13

INTRODUCTION

Thank You for purchasing a Gorman-Rupp pump. **Read this manual** carefully to learn how to safely install and operate your pump. Failure to do so could result in personal injury or damage to the pump.

Because pump installations are seldom identical, this manual cannot possibly provide detailed instructions and precautions for every aspect of each specific application. Therefore, it is the responsibility of the owner/installer of the pump to ensure that applications not addressed in this manual are performed **only** after establishing that neither operator safety nor pump integrity are compromised by the installation. Pumps and related equipment **must** be installed and operated according to all national, local and industry standards.

If there are any questions regarding the pump or its application which are not covered in this manual or in other literature accompanying this unit, please contact your Gorman-Rupp distributor, or The Gorman-Rupp Company:

The Gorman-Rupp Company
P.O. Box 1217
Mansfield, Ohio 44901-1217
Phone: (419) 755-1011
 or:
Gorman-Rupp of Canada Limited
70 Burwell Road
St. Thomas, Ontario N5P 3R7
Phone: (519) 631-2870

For information or technical assistance on the power source, contact the power source manufacturer's local dealer or representative.

HAZARD AND INSTRUCTION DEFINITIONS

The following are used to alert maintenance personnel to procedures which require special attention, to those which could damage equipment, and to those which could be dangerous to personnel:



Immediate hazards which WILL result in severe personal injury or death. These instructions describe the procedure required and the injury which will result from failure to follow the procedure.



Hazards or unsafe practices which COULD result in severe personal injury or death. These instructions describe the procedure required and the injury which could result from failure to follow the procedure.



Hazards or unsafe practices which COULD result in minor personal injury or product or property damage. These instructions describe the requirements and the possible damage which could result from failure to follow the procedure.

NOTE

Instructions to aid in installation, operation, and maintenance or which clarify a procedure.

SAFETY – SECTION A

This information applies to 0 Series power take-off pumps. Refer to the manual accompanying the power source before attempting to begin operation.

Because pump installations are seldom identical, this manual cannot possibly provide detailed instructions and precautions for each specific application. Therefore, it is the owner/installer's responsibility to ensure that applications not addressed in this manual are performed only after establishing that neither operator safety nor pump integrity are compromised by the installation.



Before attempting to open or service the pump:

1. Familiarize yourself with this manual.
2. Switch off the vehicle ignition and remove the key to ensure that the pump will remain inoperative.
3. Allow the pump to completely cool if overheated.
4. Check the temperature before opening any covers, plates, or plugs.
5. Close the suction and discharge valves.
6. Vent the pump slowly and cautiously.
7. Drain the pump.



This pump is designed for vehicular mounting in petroleum service. Do not attempt to pump corrosive materials which may damage the pump or endanger personnel as a result of pump failure.



If this pump is used with volatile and/or flammable liquids, be certain proper safety practices are followed before operating or servicing the pump. Provide adequate ventilation, prohibit smoking, wear static-resistant clothing and shoes. Clean up all fuel spills immediately after occurrence.



Death or serious personal injury and damage to the pump or components can occur if proper lifting procedures are not observed. Make certain that hoists, chains, slings or cables are in good working condition and of sufficient capacity and that they are positioned so that loads will be balanced and the pump or components will not be damaged when lifting. Suction and discharge hoses and piping must be removed from the pump before lifting. Lift the pump or component only as high as necessary and keep personnel away from suspended objects.



After the pump has been positioned, make certain that the pump and all piping connections are tight, properly supported and secure before operation.



Do not operate the pump without the shields and/or guards in place over the rotating parts. Exposed rotating parts

can catch clothing, fingers, or tools, causing severe injury to personnel.



Do not operate the pump against a closed discharge valve for long periods of time. If operated against a closed discharge valve, pump components will deteriorate, and the liquid could come to a boil, build pressure, and cause the pump casing to rupture or explode.



If this pump is used with volatile and/or flammable liquids, overheating may produce dangerous fumes. Take precautions to ensure the area surrounding the pump is adequately ventilated. Allow the pump to cool and use extreme caution when venting the pump, or when removing covers, plates, plugs, or fitting.



Overheated pumps can cause severe burns and injuries. If overheating of the pump occurs:

1. Stop the pump immediately.
2. Ventilate the area.
3. Allow the pump to completely cool.
4. Check the temperature before opening any covers, plates, gauges, or plugs.
5. Vent the pump slowly and cautiously.
6. Refer to instructions in this manual before restarting the pump.



After the vehicle is positioned for pump

maintenance, block the wheels and set the emergency brake before attempting to disconnect the drive shaft or remove the pump. Be sure the pump is properly reinstalled and secure before operation.



Do not remove plates, covers, gauges, pipe plugs, or fittings from an overheated pump. Vapor pressure within the pump can cause parts being disengaged to be ejected with great force. Allow the pump to completely cool before servicing.



The gearbox provided on this pump is designed for operation at 1000 RPM maximum input speed. If operated at a higher RPM, pump components may be destroyed.



Never run this pump backwards. Be certain that rotation is correct before fully engaging the pump.



Never run the pump dry of pumping medium. There must be a supply of liquid to the pump at all times to prevent destruction of the shaft seal faces.



Pumps and related equipment must be installed and operated according to all national, local and industry standards.

INSTALLATION – SECTION B

Review all SAFETY information in Section A.

Since pump installations are seldom identical, this section offers only general recommendations and practices required to inspect, position, and arrange the pump and piping.



Do not test or operate your pump and integral gearbox before reading the installation and operation instructions in this manual.

This pump is a self-priming centrifugal model with an integral gearbox assembly. It is designed for vehicular mounting in petroleum service, where the liquid is supplied to the pump under pressure. Since the pressure supplied to the pump is critical to performance and safety, **be sure** to limit the in-

coming pressure to 50% of the maximum permissible operating pressure as shown on the pump performance curve (see Section E, Page 1).

The integral gearbox is designed to be driven through the vehicle transfer case by a customer-supplied universal shaft assembly. The pump casing or gearbox may be rotated in 45° increments to assist with alignment with the vehicle tank; however, if the gearbox is to be rotated, some modifications must be made to the gearbox to ensure adequate lubrication. Consult the factory for details.

For further assistance, contact your Gorman-Rupp distributor or the Gorman-Rupp Company.

Pump Dimensions

See Figure 1 for the approximate physical dimensions of this pump.

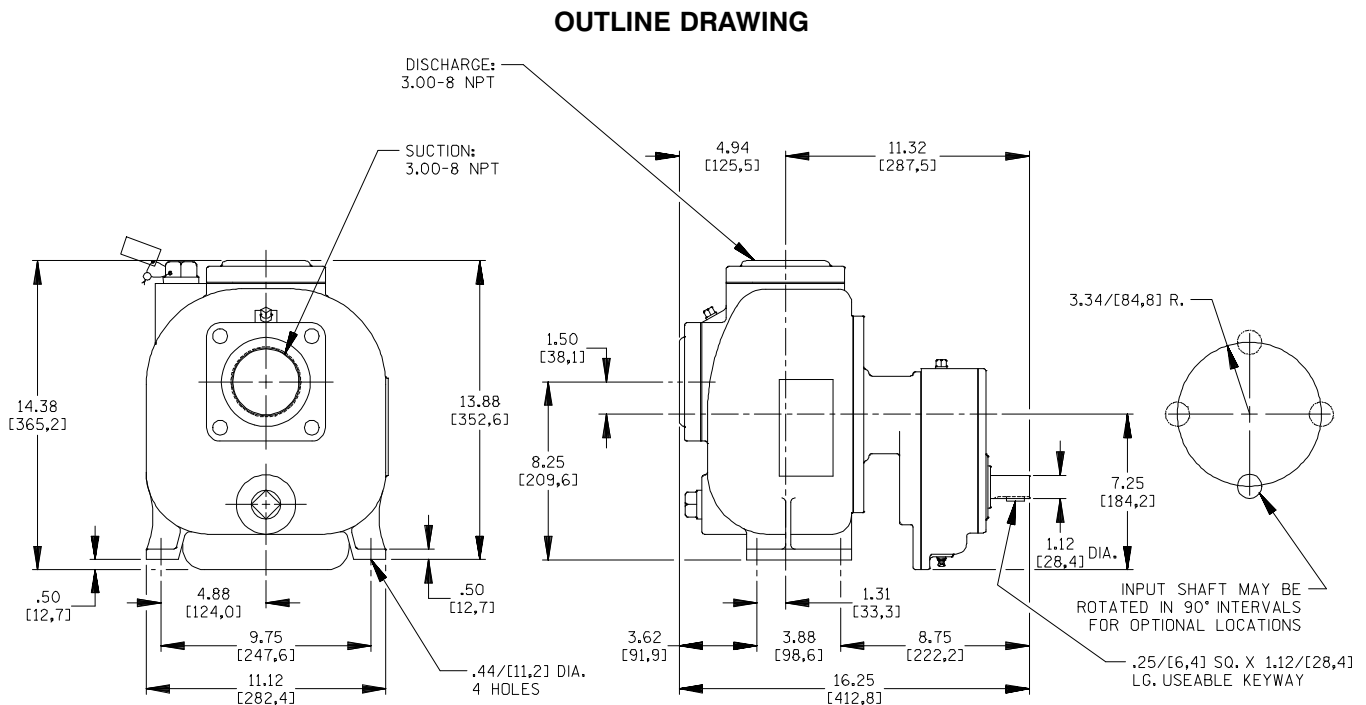

PREINSTALLATION INSPECTION

The pump assembly was inspected and tested before shipment from the factory. Before installation, inspect the pump for damage which may have occurred during shipment. Check as follows:

- a. Inspect the pump and gearbox for cracks, dents, damaged threads, and other obvious damage.
- b. Check for and tighten loose attaching hardware. Since gaskets tend to shrink after drying, check for loose hardware at mating surfaces.
- c. Carefully read all tags, decals, and markings on the pump assembly, and perform all duties indicated. Note the direction of rotation indicated on the pump. Check that the pump shaft rotates in the required direction.

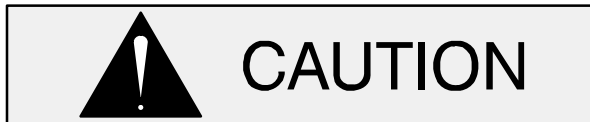

Only operate this pump in the direction indicated on the pump body and/or the accompanying decal. Reverse rotation of the shaft will adversely effect pump performance, and the pump and/or gearbox could be seriously damaged.

- d. Check levels and lubricate as necessary. Refer to **LUBRICATION** in the **MAINTENANCE AND REPAIR** section of this manual and perform duties as instructed.
- e. If the pump and gearbox have been stored for more than 12 months, some of the components or lubricants may have exceeded their maximum shelf life. These **must be inspected or replaced** to ensure maximum pump service.

If the maximum shelf life has been exceeded, or if anything appears to be abnormal, contact your Gorman-Rupp distributor or the factory to determine the repair or updating policy. **Do not** put the pump into service until appropriate action has been taken.

VEHICLE REQUIREMENTS

The following instructions apply equally to new installations, rebuilds or retrofits.

Tank Preparation

It is **essential** that any tank scale, dirt, or other foreign material be removed from the tank and piping prior to pump installation. Failure to do so could result in clogging or damage to the pump.



Damage to the pump resulting from debris in the suction line **will not** be covered by the pump warranty.

Before connecting the suction and discharge piping, carefully check the storage tank and piping for construction debris such as nuts, bolts, wire, weld slag, and other foreign material. Install a commercially available 80 mesh screen in the suction line to prevent debris from entering the pump.

POSITIONING PUMP



Death or serious personal injury and damage to the pump or components can occur if proper lifting procedures are not observed. Make certain that hoists, chains, slings or cables are in good working condition and of sufficient capacity and that they are positioned so that loads will be balanced and the pump or components will not be damaged when lifting. Suction and discharge hoses and piping must be removed from the pump before lifting. Lift the pump or component only as high as necessary and keep personnel away from suspended objects.

Lifting

Pump unit weights will vary depending on the mounting and drive provided. Check the shipping tag on the unit packaging for the actual weight, and use lifting equipment with appropriate capacity. Drain the pump and remove all customer-installed equipment such as suction and discharge hoses or piping before attempting to lift existing, installed units.



The pump assembly can be seriously damaged if the cables or chains used to lift and move the unit are improperly wrapped around the pump.

Due to the confined mounting location, specialized equipment such as a transmission jack with custom brackets should be used to lift and position the pump and gearbox.

NOTE

If the gearbox is rotated out of the standard position shown in Figure 1, the oil fill and drain plugs must be relocated. The oil vent must be relocated to the highest port. Consult the factory for correct positioning of the fill plug to provide for proper lubrication of the gearbox.

ALIGNMENT



When installing and/or aligning universal shaft assemblies, disconnect the power source to ensure that the pump will remain inoperative.

The alignment of the pump and its power source is critical for trouble-free mechanical operation. Before checking alignment, make sure that the gearbox mounting bolts are tight.

When connecting the universal joint drive shaft assembly to a PTO unit, install, support, and align the drive shaft in accordance with the manufacturer's instructions. The pump and the drive power source are generally positioned so that shaft centerlines are parallel and horizontal. The maximum operating angle should not exceed 15° (see Figure 2).

Check the direction of rotation of the PTO unit before starting the pump. The drive shaft must rotate in the direction shown on the body of the pump, gearbox, and/or decals, tags, and labels.



Do not operate the pump without the guard in place over the rotating parts. Exposed rotating parts can catch clothing, fingers, or tools, causing severe injury to personnel.

After the power take-off has been aligned, block the wheels of the external power source, engage the braking system, or take other precautions to ensure that the power source will remain stationary. Block the wheels on the unit to prevent creeping.

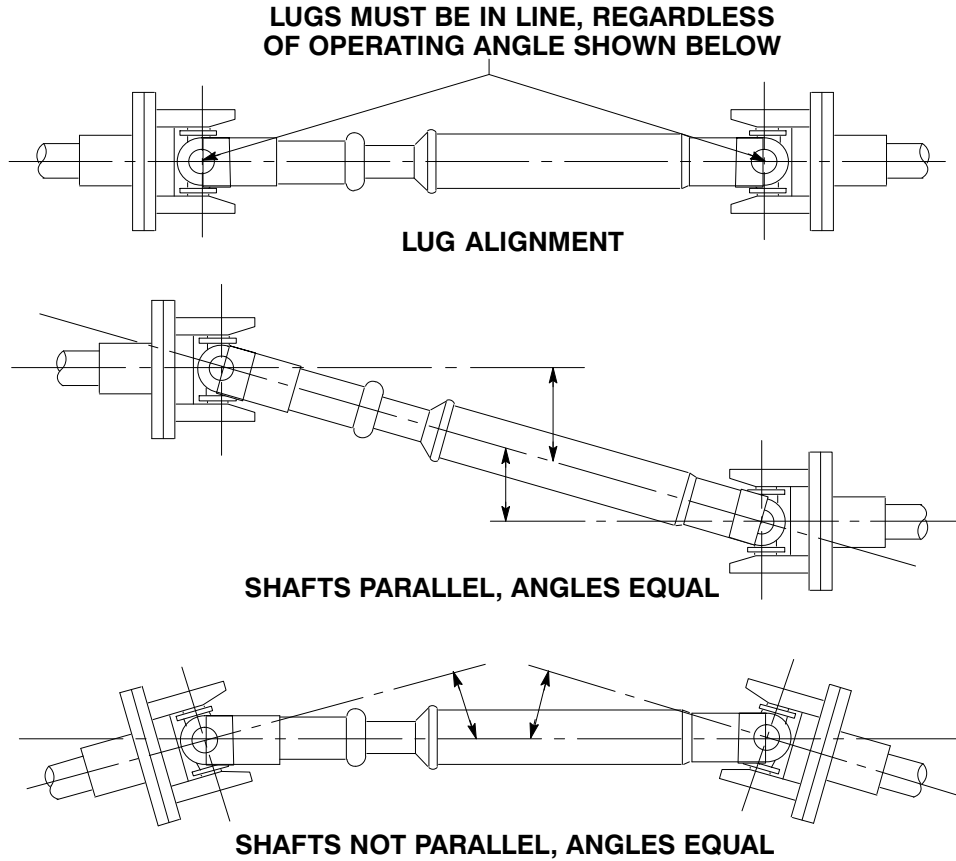

Figure 2. Proper Installation And Alignment of Universal Assembly

SUCTION AND DISCHARGE PIPING

tors, related piping and safety accessories. Some of the accessories are available from Gorman-Rupp as optional equipment.

Typical System Installation

Tank filling and dispensing operations require a system utilizing flow-directing (FDF) valves, educ-

Refer to Figures 3 and 4 for illustrations of typical piping systems for tank filling and dispensing.

SCHEMATIC SYSTEM USING EDUCATOR FOR DISPENSING AND FILLING

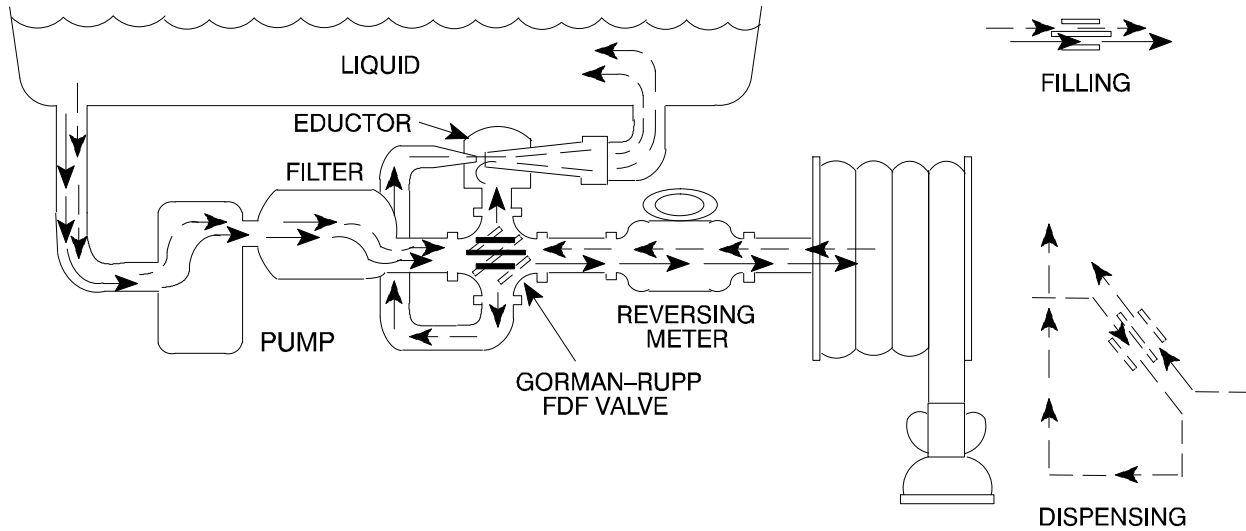
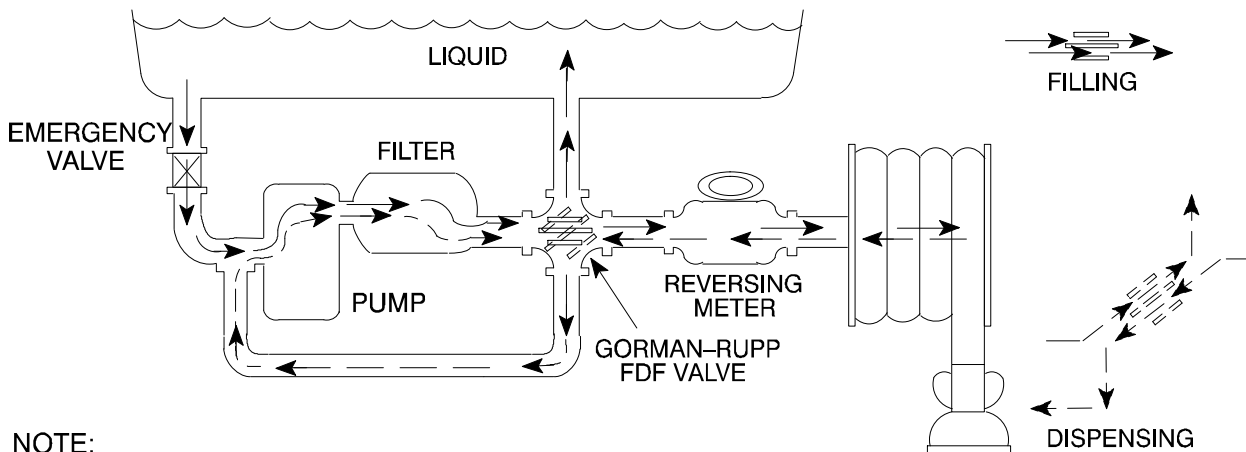

Figure 3. Typical Installation Using Educator For Filling And Dispensing

SCHEMATIC SYSTEM USING PUMP FOR DISPENSING AND FILLING



NOTE:
 EMERGENCY VALVE OPEN FOR FILLING
 EMERGENCY VALVE CLOSED FOR DISPENSING

Figure 4. Typical Installation Using Pump For Filling And Dispensing

Piping

All piping material must be compatible with the liquid being pumped. If hose is used in suction lines, it must be the rigid-wall, reinforced type to prevent collapse under suction. Using piping couplings in suction lines is not recommended.

A suction strainer was not furnished with this pump since it is **not** designed to handle liquids containing solids. However, to protect the pump from accidental damage a commercially available 80 mesh screen should be installed in the suction line. Make certain that the total open area of the screen is at least three or four times the cross section of the

suction line to ensure an adequate supply of liquid to the pump.

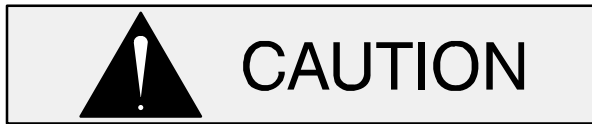

Damage To the pump resulting from debris in the suction line **will not** be covered by the pump warranty.

Before connecting the suction and discharge piping, carefully check the storage tank and piping for construction debris such as nuts, bolts, wire, weld slag, and other foreign material. Install a commercially available 80 mesh screen in the suction line to prevent debris from entering the pump.

If a throttling valve is desired in the discharge line, use a valve as large as the largest pipe to minimize friction losses. Never install a throttling valve in a suction line.

With high discharge heads, it is recommended that a throttling valve and a system check valve be installed in the discharge line to protect the pump from excessive shock pressure and reverse rotation when it is stopped.

Sealing

Since even a slight leak will affect priming, head, and capacity, especially when operating with a high suction lift, all connections in the suction line should be sealed with pipe dope to ensure an airtight seal. Follow the sealant manufacturer's recommendations when selecting and applying the pie dope.

Valves

Gorman-Rupp manufactures several sizes of flow-diverting (FDF) valves for use in truck-mounted pumping applications. The valves are designed to reverse the flow of liquid with only the turn of a handle. This allows the same pump to fill or dispense from the tank.



The FDF valve is designed for directing flow only. it will not serve as a positive shut-off or throttling valve.

See Figure 5 illustrating the theory of operation for a typical FDF valve. Consult the factory for further assistance or other sizes.

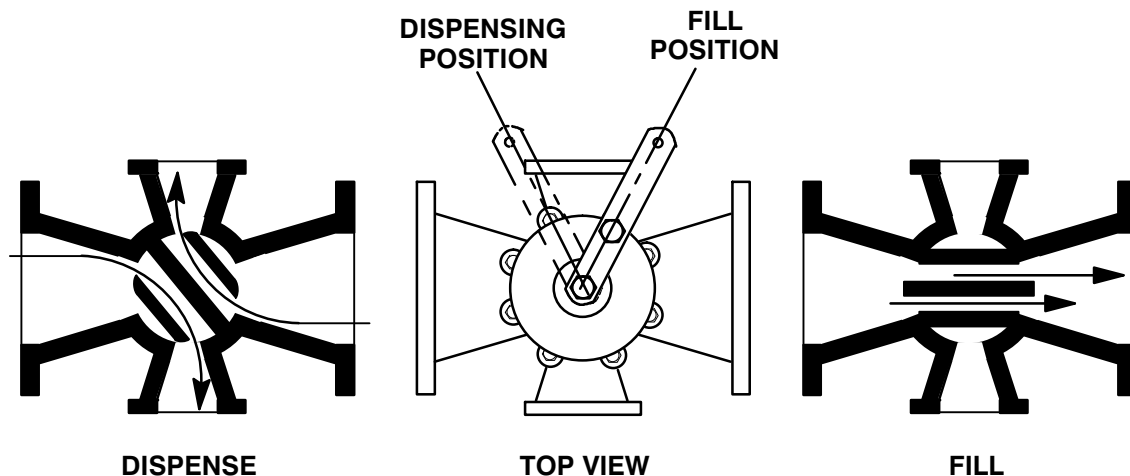

Figure 5. FDF Valve Theory of Operation

When the center web of the valve is aligned with the larger ports (filling position), the flow passes straight through. When the handle is turned to the

dispensing position, the web blocks the straight flow and opens two paths of flow through the larger ports to the smaller ports.

Siphoning

Do not terminate the discharge line at a level lower than that of the liquid being pumped unless a siphon breaker is used in the line. Otherwise, a siphoning action causing damage to the pump could result.

Eductors

An eductor may be used in conjunction with an

FDF valve to increase dispensing rates and improve efficiency. An educator may also be used to collapse the tank service hose after the tank has been filled or emptied.

Contact the Gorman-Rupp Company or an authorized distributor for specifications and performance data on eductors or FDF valves.

OPERATION – SECTION C

Review all **SAFETY** information in Section A.

Follow the instructions on all tags, labels and decals attached to the pump.



This pump is designed for vehicular mounting in petroleum service. Do not attempt to pump corrosive materials, or any liquids which may damage the pump or endanger personnel as a result of pump failure.



The gearbox provided on this pump is designed for operation at 1000 RPM maximum input speed. If operated at a higher RPM, pump components may be destroyed.

PRIMING

Install the pump and piping as described in **INSTALLATION**. Make sure that the piping connections are tight, and that the pump is securely mounted. Check that the pump is properly lubricated (see **LUBRICATION** in **MAINTENANCE AND REPAIR**).

This pump is self-priming, but the pump should never be operated unless there is liquid in the pump casing.



Never operate this pump unless there is liquid in the pump casing. The pump will not prime when dry. Extended operation of a dry pump will destroy the seal assembly.

Add liquid to the pump casing when:

1. The pump is being put into service for the first time.
2. The pump has not been used for a considerable length of time.
3. The liquid in the pump casing has evaporated.

When installed in a flooded suction application, simply open the system valves and permit the incoming liquid to evacuate the air. After the pump and piping system have completely filled, evacuate any remaining air pockets in the pump or suction line by loosening a pipe plug or opening bleeder valves.

Once the pump casing has been filled, the pump will prime and reprime as necessary.

GROUNDING

To eliminate electrostatic build-up when pumping petroleum products, the pump must be grounded by attaching a ground wire to a ground rod. Install the ground rod in accordance with the National Electric Code and all local codes. Be sure the clamp or fastener has made a tight electrical connection with the rod.



Inspect and test the ground wire assembly for conductivity. Replace broken or frayed wire before resuming operation.

STARTING

Consult the operations manual furnished with the power source.

Rotation

The correct direction of pump rotation is clockwise when facing the input drive shaft. The pump could

be damaged and performance adversely affected by incorrect rotation. If pump performance is not within the specified limits (see the curve on Page E-1), check the direction of rotation before further troubleshooting.

Drive

This pump is designed for operation with a power take-off unit coupled to the drive shaft on the gearbox. The gearbox assembly has a ratio of 4.09:1, and is designed for operation at 1000 RPM. **Do not** operate at a higher input speed.



The gearbox provided on this pump is designed for operation at 1000 RPM maximum. If operated at a higher rpm, pump components may be destroyed.

OPERATION



Pump speed and operating condition points must be within the continuous performance range shown on the curve (see Section E, Page 1).

Partially open the discharge throttling valve so that the discharge line fills slowly to prevent damage to piping, gaskets, and other devices in the line which could be affected by shock resulting from rapid filling of the line. When the discharge line is completely filled, adjust the discharge throttling valve to the desired flow rate.

Leakage

No leakage should be visible at pump mating surfaces, or at pump connections or fittings. Keep all line connections and fittings tight to maintain maximum pump efficiency.

Liquid Temperature And Overheating

The **maximum** liquid temperature for this pump is 160°F (71°C). Do not apply it at a higher operating temperature.

Overheating can occur if operated with the valves in the suction or discharge lines closed. Operating against closed valves could bring the liquid to a boil, build pressure, and cause the pump to rupture or explode. If overheating occurs, stop the pump and allow it to cool before servicing it. Refill the pump casing with cool liquid.



Allow an overheated pump to completely cool before servicing. Do not remove plates, covers, gauges, pipe plugs, or fittings from an overheated pump. Liquid within the pump can reach boiling temperatures, and vapor pressure within the pump can cause parts being disengaged to be ejected with great force. After the pump cools, drain the liquid from the pump by removing the casing drain plug. Use caution when removing the plug to prevent injury to personnel from hot liquid.

Strainer Check

If a suction strainer has been shipped with the pump or installed by the user, check the strainer regularly, and clean it as necessary. The strainer should also be checked if pump flow rate begins to drop. If a vacuum suction gauge has been installed, monitor and record the readings regularly to detect strainer blockage.

Never introduce air or steam pressure into the pump casing or piping to remove a blockage. This could result in personal injury or damage to the equipment. If backflushing is absolutely necessary, **liquid pressure** must be limited to 50% of the maximum permissible operating pressure shown on the pump performance curve. (See Section E, Page 1.)

Pump Vacuum Check

Since this pump does not have a suction check valve, the discharge line must be fitted with a check valve if a pump vacuum reading is to be taken.

With the pump inoperative, install a vacuum gauge in the system, using pipe dope on the threads. Block the suction line and start the pump. At operating speed the pump should pull a vacuum of 20 inches (508,0 mm) or more of mercury. If it does not, check for air leaks in the seal, gasket, or discharge valve.

Open the suction line, and read the vacuum gauge with the pump primed and at operation speed. Shut off the pump. The vacuum gauge reading will immediately drop proportionate to static suction lift, and should then stabilize. If the vacuum reading falls off rapidly after stabilization, an air leak exists. Before checking for the source of the leak, check the point of installation of the vacuum gauge.

NOTE

Petroleum products are very sensitive to changes in temperature. Warmer temperatures elevate the product vapor pressure, resulting in low vacuum readings. Do not mistake temperature problems for faulty pump installation or performance.

STOPPING

Never halt the flow of liquid suddenly. If the liquid being pumped is stopped abruptly, damaging shock waves can be transmitted to the pump and piping system. Close all connecting valves slowly.

On engine driven pumps, reduce the throttle speed slowly and allow the engine to idle briefly before stopping.



If the application involves a high discharge head, gradually close the discharge throttling valve before stopping the pump.

After stopping the pump, remove the engine ignition key to ensure that the pump will remain inoperative.

Cold Weather Preservation

If the application of this pump is limited to petroleum products, normal freezing conditions will not damage the pump. However, during extremely severe conditions care should be exercised during start-up, especially if the pump has been idle for more than a few hours.

GEARBOX TEMPERATURE CHECK

The gearbox runs higher than ambient temperatures because of heat generated by friction. Temperatures of approximately 200°F (93°C) are considered normal, and can operate intermittently at 250°F (121°C).

Checking gearbox temperatures by hand is inaccurate. Place a contact-type thermometer against the housing and record this temperature for future reference.

A sudden increase in gearbox temperature is a warning that the bearings are at the point of failing. Make certain that the bearing lubricant is of the proper viscosity and at the correct level (see **LUBRICATION** in Section E). Bearing overheating can also be caused by shaft misalignment and/or excessive vibration.

When pumps are first started, the bearings may seem to run at temperatures above normal. Continued operation should bring the temperatures down to normal levels within 20 minutes or less.

TROUBLESHOOTING – SECTION D

Review all SAFETY information in Section A.



Before attempting to open or service the pump:

1. **Familiarize yourself with this manual.**
2. **Switch off the vehicle ignition and remove the key, or take other precautions to ensure that the pump will remain inoperative.**
3. **Allow the pump to completely cool if overheated.**
4. **Check the temperature before opening any covers, plates, or plugs.**
5. **Close the suction and discharge valves.**
6. **Vent the pump slowly and cautiously.**
7. **Drain the pump.**

TROUBLE	POSSIBLE CAUSE	PROBABLE REMEDY
PUMP FAILS TO PRIME	<p>Not enough liquid in casing.</p> <p>Air leak in suction line.</p> <p>Lining of suction hose collapsed.</p> <p>Leaking or worn seal or pump gasket.</p> <p>Pump speed too slow.</p> <p>Strainer clogged.</p>	<p>Add liquid to casing. See PRIMING.</p> <p>Correct leak.</p> <p>Replace suction hose.</p> <p>Check pump vacuum. Replace leaking or worn seal or gasket.</p> <p>Check power source output; consult power source operation manual.</p> <p>Check strainer and clean if necessary.</p>
PUMP STOPS OR FAILS TO DELIVER RATED FLOW OR PRESSURE	<p>Air leak in suction line.</p> <p>Suction intake not submerged at proper level or sump too small.</p> <p>Lining of suction hose collapsed.</p> <p>Leaking or worn seal or pump gasket.</p>	<p>Correct leak.</p> <p>Check installation and correct submergence as needed.</p> <p>Replace suction hose.</p> <p>Check pump vacuum. Replace leaking or worn seal or gasket.</p>

TROUBLE	POSSIBLE CAUSE	PROBABLE REMEDY
PUMP STOPS OR FAILS TO DELIVER RATED FLOW OR PRESSURE (cont.)	<p>Impeller or other wearing parts worn or damaged.</p> <p>Suction lift or discharge head too high.</p> <p>Pump speed too slow.</p> <p>Discharge line clogged or restricted; hose kinked.</p>	<p>Replace worn or damaged parts. Check that impeller is properly centered and rotates freely.</p> <p>Check piping installation and install bypass line if needed. See INSTALLATION.</p> <p>Check power source output; consult power source operation manual.</p> <p>Check discharge lines; straighten hose.</p>
PUMP REQUIRES TOO MUCH POWER	<p>Universal joint drive misaligned.</p> <p>Pump speed too high.</p> <p>Discharge head too low.</p>	<p>Align drive.</p> <p>Check driver output; check that sheaves or couplings are correctly sized.</p> <p>Adjust discharge valve.</p>
EXCESSIVE NOISE	<p>Cavitation in pump.</p> <p>Pumping entrained air.</p> <p>Pump or drive not securely mounted.</p> <p>Universal joint drive misaligned.</p> <p>Low or incorrect lubricant.</p>	<p>Reduce suction lift and/or friction losses in suction line. Record vacuum and pressure gauge readings and consult local representative or factory.</p> <p>Locate and eliminate source of air bubble.</p> <p>Secure mounting hardware.</p> <p>Align drive.</p> <p>Check for proper type and level of lubricant.</p>
BEARINGS RUN TOO HOT	<p>Bearing temperature is high, but within limits.</p> <p>Low or incorrect lubricant.</p> <p>Suction and discharge lines not properly supported.</p> <p>Drive misaligned; piping improperly installed.</p> <p>Bearings in power source or gearbox worn or binding.</p>	<p>Check bearing temperature regularly to monitor any increase.</p> <p>Check for proper type and level of lubricant.</p> <p>Check piping installation for proper support.</p> <p>Realign drive and piping at operating temperature. Add expansion joints if required.</p> <p>Check bearings.</p>

PREVENTIVE MAINTENANCE

Since pump applications are seldom identical, and pump wear is directly affected by such things as the abrasive qualities, pressure and temperature of the liquid being pumped, this section is intended only to provide general recommendations and practices for preventive maintenance. Regardless of the application however, following a routine preventive maintenance schedule will help assure trouble-free performance and long life from your Gorman-Rupp pump. For specific questions concerning your application, contact your Gorman-Rupp distributor or the Gorman-Rupp Company.

Record keeping is an essential component of a good preventive maintenance program. Changes in suction and discharge gauge readings (if so

equipped) between regularly scheduled inspections can indicate problems that can be corrected before system damage or catastrophic failure occurs. The appearance of wearing parts should also be documented at each inspection for comparison as well. Also, if records indicate that a certain part (such as the seal) fails at approximately the same duty cycle, the part can be checked and replaced before failure occurs, reducing unscheduled down time.

For new applications, a first inspection of wearing parts at 250 hours will give insight into the wear rate for your particular application. Subsequent inspections should be performed at the intervals shown on the chart below. Critical applications should be inspected more frequently.

Preventive Maintenance Schedule					
Item	Service Interval*				
	Daily	Weekly	Monthly	Semi-Annually	Annually
General Condition (Temperature, Unusual Noises or Vibrations, Cracks, Leaks, Loose Hardware, Etc.)	I				
Pump Performance (Gauges, Speed, Flow)	I				
Bearing Lubrication		I			R
Seal Lubrication (And Packing Adjustment, If So Equipped)		I			R
V-Belts (If So Equipped)			I		
Air Release Valve Plunger Rod (If So Equipped)			I	C	
Front Impeller Clearance (Wear Plate)				I	
Rear Impeller Clearance (Seal Plate)				I	
Check Valve					I
Pressure Relief Valve (If So Equipped)					C
Pump and Driver Alignment					I
Shaft Deflection					I
Bearings					I
Bearing Housing					I
Piping					I
Driver Lubrication – See Mfgr’s Literature					I

Legend:
 I = Inspect, Clean, Adjust, Repair or Replace as Necessary
 C = Clean
 R = Replace

* Service interval based on an intermittent duty cycle equal to approximately 4000 hours annually. Adjust schedule as required for lower or higher duty cycles or extreme operating conditions.

PUMP MAINTENANCE AND REPAIR - SECTION E

MAINTENANCE AND REPAIR OF THE WEARING PARTS OF THE PUMP WILL MAINTAIN PEAK OPERATING PERFORMANCE.

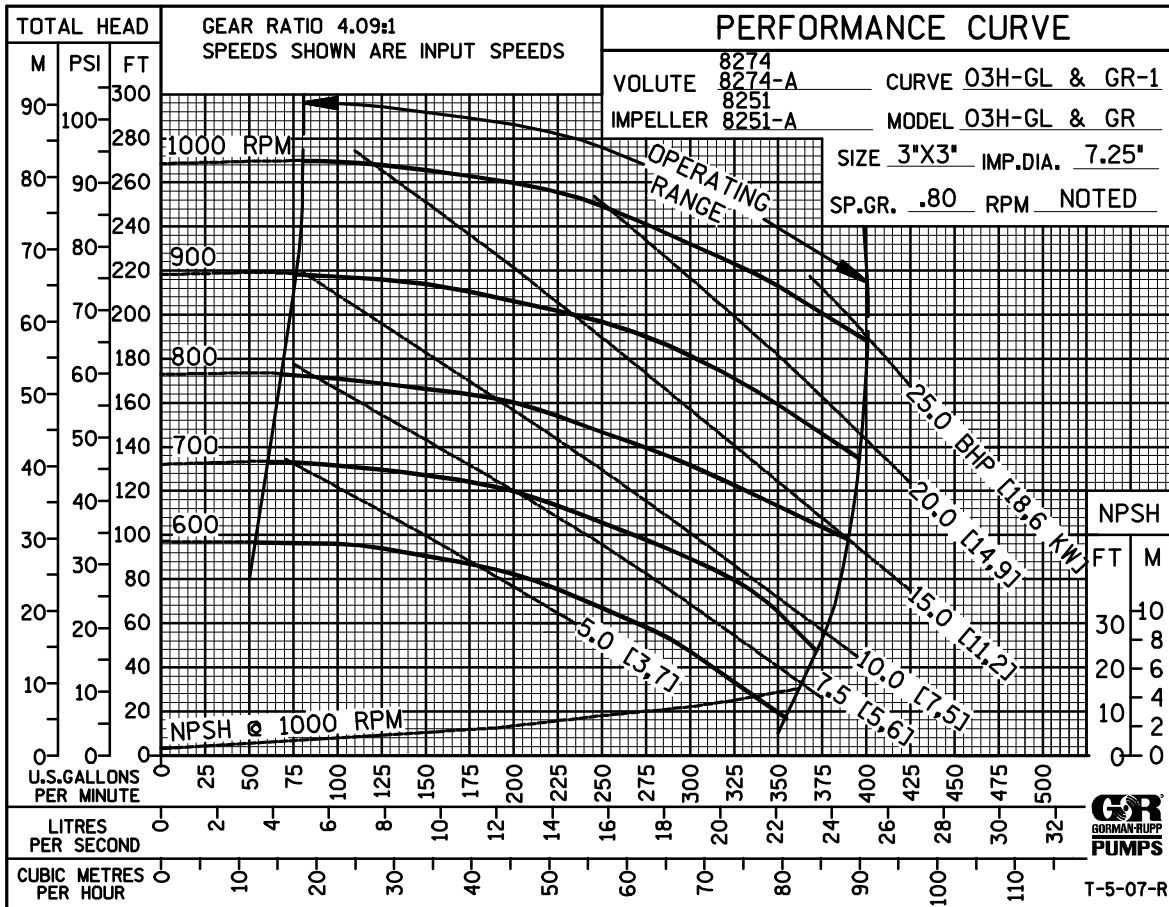

*** STANDARD PERFORMANCE FOR PUMP MODEL 03H1-GR**

* Based on 70°F (21°C) clear water corrected to 0.8 specific gravity at sea level with minimum suction lift. Since pump installations are seldom identical, your performance may be difference due to such factors as viscosity, specific gravity, elevation, temperature, and impeller trim.

Contact the Gorman-Rupp Company to verify performance or part numbers.



Pump speed and operating condition points must be within the continuous performance range shown on the curve.

If your pump serial number is followed by an "N", your pump is **NOT** a standard production model.

SECTION DRAWING

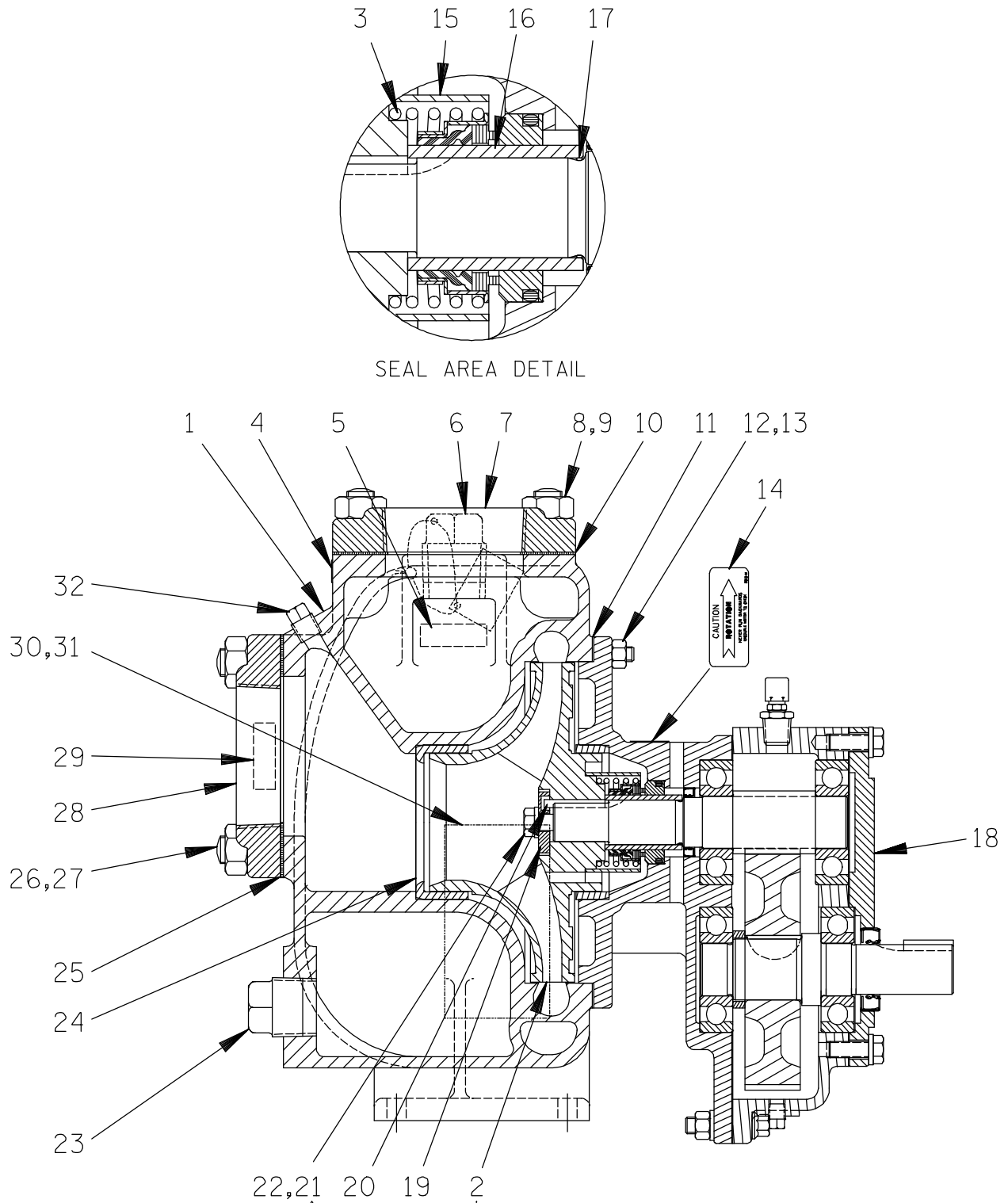

Figure 1. Pump Model 03H1-GR

PARTS LIST
Pump Model 03H1-GR
 (From S/N 287634 Up)

If your pump serial number is followed by an "N", your pump is **NOT** a standard production model. Contact the Gorman-Rupp Company to verify part numbers.

ITEM NO.	PART NAME	PART NUMBER	QTY
☞ 1	PUMP CASING	SEE NOTE BELOW	1
2	* IMPELLER	8251A 13010	1
3	* SEAL ASSEMBLY	25271-192	1
4	DISCHARGE STICKER	6588BJ	1
5	FL HERE TO PRM STK	6588AH	1
☞ 6	FILL PLUG ASSY	48271-064	1
7	DISCHARGE FLANGE	1390 13040	1
8	STUD	C1009 15991	4
9	HEX NUT	D10 15991	4
10	* DISCH GASKET	1318GB 20000	1
11	* PUMP CASING GSKT SET	48211-094	1
☞ 12	STUD	C0605 1/2 15991	8
13	HEX NUT	D06 15991	8
14	ROTATION DECAL	2613M	1
15	SEAL GUARD	9834 14090	1
16	* SHAFT SLEEVE	9140 16000	1
17	* SHAFT SLEEVE O-RING	S1461	1
18	GEARBOX ASSEMBLY	44161-014	1
19	* IMPELLER WASHER	6750 13090	1
20	* IMPELLER KEY	N0305-1/2 15990	1
21	NYLOCK CAPSCREW	BT0605 15991	1
22	NORD-LOCK WASHER	21177-218	1
☞ 23	CASING DRAIN PLUG	P20 10009	1
☞ 24	* WEAR RING	62ZL5 14000	1
☞ 25	* SUCT FLANGE GSKT	1318GB 20000	1
☞ 26	STUD	C1009 15991	4
☞ 27	HEX NUT	D10 15991	4
☞ 28	SUCTION FLANGE	1390 13040	1
29	SUCTION STICKER	6588AG	1
30	NAME PLATE	38818-018 13990	1
31	DRIVE SCREW	BM#04-03 17000	4
☞ 32	PIPE PLUG	P04 15079	1
☞	INCLUDED W/REPAIR PUMP CASING ASSY	46475-005	1

* INDICATES PARTS RECOMMENDED FOR STOCK

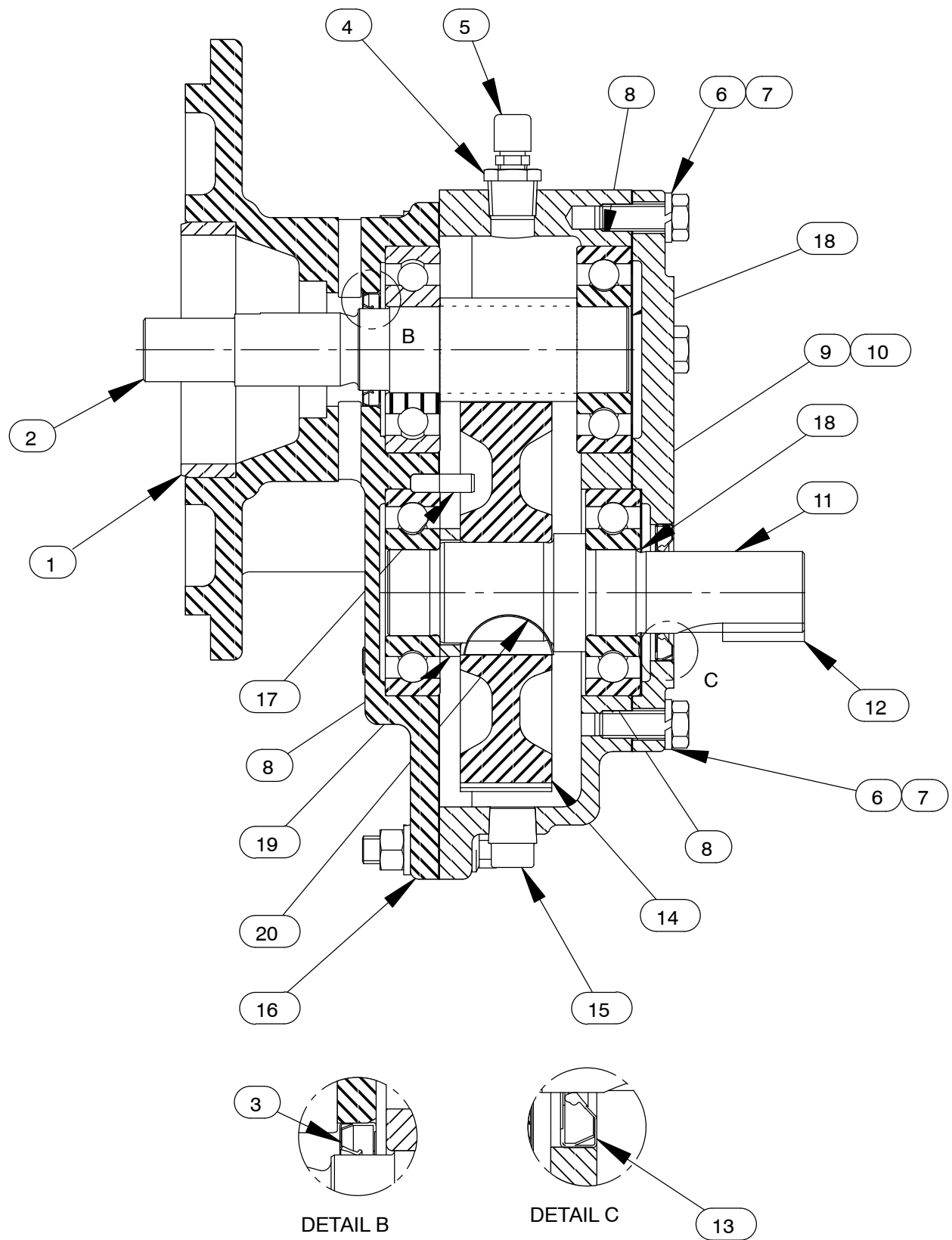

Figure 2. 44161-014 Gearbox Assembly

PARTS LIST
44161-014 Gearbox Assembly

ITEM NO.	PART NAME	PART NUMBER	QTY
1	WEAR RING	62ZL6 14000	1
2	PINION	8896 16020	1
3	* OIL SEAL	S1764	1
4	REDUCER PIPE BUSHING	AP0602 15079	1
5	AIR VENT	S1530	1
6	LOCK WASHER	J06 15991	6
7	HEX HEAD CAP SCREW	B0604 15991	6
8	* BALL BEARING	S390	4
9	* COVER PLATE GASKET	8871G 18000	1
10	COVER PLATE	8871 10010	1
11	DRIVE SHAFT	8837 16040	1
12	* KEY	N0404-1/2 15990	1
13	* OIL SEAL	S389	1
14	HELICAL GEAR	8895 16060	1
15	PIPE PLUG	P06 15079	5
16	GEAR HOUSING ASSEMBLY	8914	1
17	DOWEL PIN	AA0403-1/2 15990	2
18	* ADJUSTABLE SHIM SET	S464	2
19	SPACER SLEEVE	9142 15990	1
20	* WDF KEY	AV1210 15990	1
NOT SHOWN:			
	SHIPPING PLUG	11495A 15079	1
	PTO LUBE DECAL	2613CQ	1
	GEAR LUBE DECAL	38816-239	1

* INDICATES PARTS RECOMMENDED FOR STOCK

PUMP AND SEAL DISASSEMBLY AND REASSEMBLY

Review all **SAFETY** information in Section A.

Follow the instructions on all tags, label and decals attached to the pump.

This pump requires little service due to its rugged, minimum-maintenance design. However, if it becomes necessary to inspect or replace the wearing parts, follow these instructions which are keyed to the sectional views (see Figures 1 and 2) and the accompanying parts list.

Because pump installations are seldom identical, this manual cannot possibly provide detailed instructions and precautions for every aspect of each specific application. Therefore, it is the responsibility of the owner/installer of the pump to ensure that applications not addressed in this manual are performed **only** after establishing that neither operator safety nor pump integrity are compromised by the installation. Pumps and related equipment **must** be installed and operated according to all national, local and industry standards.

Most service functions, such as impeller, wear ring, and seal replacement, may be performed by draining the pump and removing the pump casing. However, due to the confined mounting location of the pump, it is recommended that the pump and gearbox be removed from the vehicle for service. The following instructions assume complete disassembly is required.

If the gearbox requires repair, proceed with **PUMP AND SEAL DISASSEMBLY**, followed by **GEARBOX DISASSEMBLY**.

Before attempting to service the pump, switch off the engine ignition and remove the key, or take other safety precautions to ensure that it will remain inoperative. Close all valves in the suction and discharge lines.



Before attempting to open or service the pump:

1. Familiarize yourself with this manual.
2. Switch off the vehicle ignition and remove the key, or take other precautions to ensure that the pump will remain inoperative.
3. Allow the pump to completely cool if overheated.
4. Check the temperature before opening any covers, plates, or plugs.
5. Close the suction and discharge valves.
6. Vent the pump slowly and cautiously.
7. Drain the pump.



After the vehicle is positioned for pump maintenance, block the wheels and set the emergency brake before attempting to disconnect the drive shaft or remove the pump. Be sure the pump is properly reinstalled and secured before operation.



Death or serious personal injury and damage to the pump or components can occur if proper lifting procedures are not observed. Make certain that hoists, chains, slings or cables are in good working condition and of sufficient capacity and that they are positioned so that loads will be balanced and the pump or components will not be damaged when lifting. Suction and discharge hoses and piping **must** be re-

moved from the pump before lifting. Lift the pump or component only as high as necessary and keep personnel away from suspended objects.

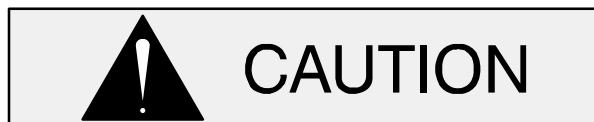

The pump assembly can be seriously damaged if the cables or chains used to lift and move the unit are improperly wrapped around the pump.

Due to the confined mounting location, specialized equipment such as a transmission jack with custom brackets should be used to lift and position the pump and gearbox.



Use **Only Genuine Gorman—Rupp** replacement parts. Failure to do so may create a hazard and damage the pump or diminish optimal pump performance. Any such hazard, damage or diminished performance is not covered by the warranty.

NOTE

When appropriate recycling facilities are available, the user should recycle components and fluids when doing any routine maintenance / repairs and also at the end of the pump's useful life. All other components and fluids shall be disposed of according to all applicable codes and regulations.

Removing Pump and Gearbox

Due to the confined mounting location, it is recommended that the pump and gearbox be removed from the vehicle for service.



The pump assembly can be seriously damaged if the cables or chains used to lift and move the unit are improperly wrapped

around the pump.

Due to the confined mounting location, specialized equipment such as a transmission jack with custom brackets should be used to lift and position the pump and gearbox.

Close all valves in the suction and discharge lines. Remove the pump casing drain plug (23) and drain the pump.

Disconnect the P.T.O. shaft from the gearbox drive shaft. Remove all the hardware securing the pump and gearbox to the vehicle chassis. Tie and tag the any leveling shims used under the casing mounting feet to ease reassembly. Move the pump and gearbox to a clean, well-equipped shop for maintenance and repair.

Pump Casing and Wear Ring Removal

(Figure 1)

To service the impeller, wear ring or seal assembly, the pump casing (1) must be separated from the seal plate (27, Figure 2).

Remove the nuts (13) and separate the pump casing and casing gasket set (11) from the seal plate. Tie and tag the gaskets, or measure and record their thickness for ease of reassembly.

Clean the mating surfaces of the seal plate and pump casing. Inspect the wear ring (24) for excessive wear or scoring. The wear ring is secured in the pump casing by a press fit. If replacement is required, use a small bit to drill two holes through the ring horizontally, 180° apart. Use a saw and chisel to complete the cuts through the ring, and remove it from the casing. **Use caution** not to damage the pump casing when removing the ring.

Impeller Removal

(Figure 1)

To loosen the impeller screw (21), immobilize the drive shaft (14, Figure 2). Remove the impeller screw, lockwasher (22), and impeller washer (19).

Use a suitable puller to remove the impeller from the shaft. Retain the impeller key (20). Use caution when removing the impeller; tension on the seal spring will be released as the impeller is removed.

NOTE

An alternate method of removing the impeller is to

use two large screwdrivers on opposite sides between the impeller and seal plate to pry the impeller off the shaft. **Use caution** not to damage the impeller.

Inspect the seal guard (15) for excessive wear or scoring. The seal guard is secured on the impeller by a press fit. If replacement is required, pull it off the impeller.

Seal Removal and Disassembly

(Figure 1)

Carefully remove the seal spring. Remove the shaft sleeve (16) and rotating portion of the seal as a unit. Apply oil to the sleeve and work it up under the bellows. Slide the rotating portion of the seal off the sleeve.

Use a pair of stiff wires with hooked ends to hook the stationary element from the back side, and pull the element and O-ring from the seal plate bore. Remove the sleeve O-ring (17).

If no further disassembly is required, proceed with **PUMP AND SEAL REASSEMBLY**. If the gearbox requires disassembly, do not reassemble the pump components at this time. Refer to **GEARBOX DISASSEMBLY** and **GEARBOX REASSEMBLY**, followed by **PUMP AND SEAL REASSEMBLY**.

PUMP AND SEAL REASSEMBLY

If the gearbox requires disassembly, refer to **GEARBOX DISASSEMBLY** and **GEARBOX REASSEMBLY**, followed by **PUMP AND SEAL REASSEMBLY**.

Seal Reassembly and Installation

(Figures 1 and 3)

Clean the seal cavity and shaft with a cloth soaked in fresh cleaning solvent.



Most cleaning solvents are toxic and flammable. Use them only in a well-ventilated area free from excessive heat, sparks, and flame. Read and follow all precautions printed on solvent containers.

The seal is not normally reused because wear patterns on the finished faces cannot be realigned during reassembly. This could result in premature failure. If necessary to reuse an old seal in an emergency, carefully wash all metallic parts in **fresh** cleaning solvent and allow to dry thoroughly.

Handle the seal parts with extreme care to prevent damage. Be careful not to contaminate precision finished faces; even fingerprints on the faces can shorten seal life. If necessary, clean the faces with a non-oil based solvent and a clean, lint-free tissue. Wipe **lightly** in a concentric pattern to avoid scratching the faces.

Inspect the seal components for wear, scoring, grooves, and other damage that might cause leakage. Clean and polish the shaft sleeve, or replace it if there are nicks or cuts on either end. If any components are worn, replace the complete seal; **never mix old and new seal parts.**

If a replacement seal is being used, remove it from the container and inspect the precision finished faces to ensure that they are free of any foreign matter.

To ease installation of the seal, lubricate the O-rings and shaft sleeve with water or a very **small** amount of oil, and apply a drop of light lubricating oil on the finished faces. Assemble the seal as follows, (see Figure E–3).

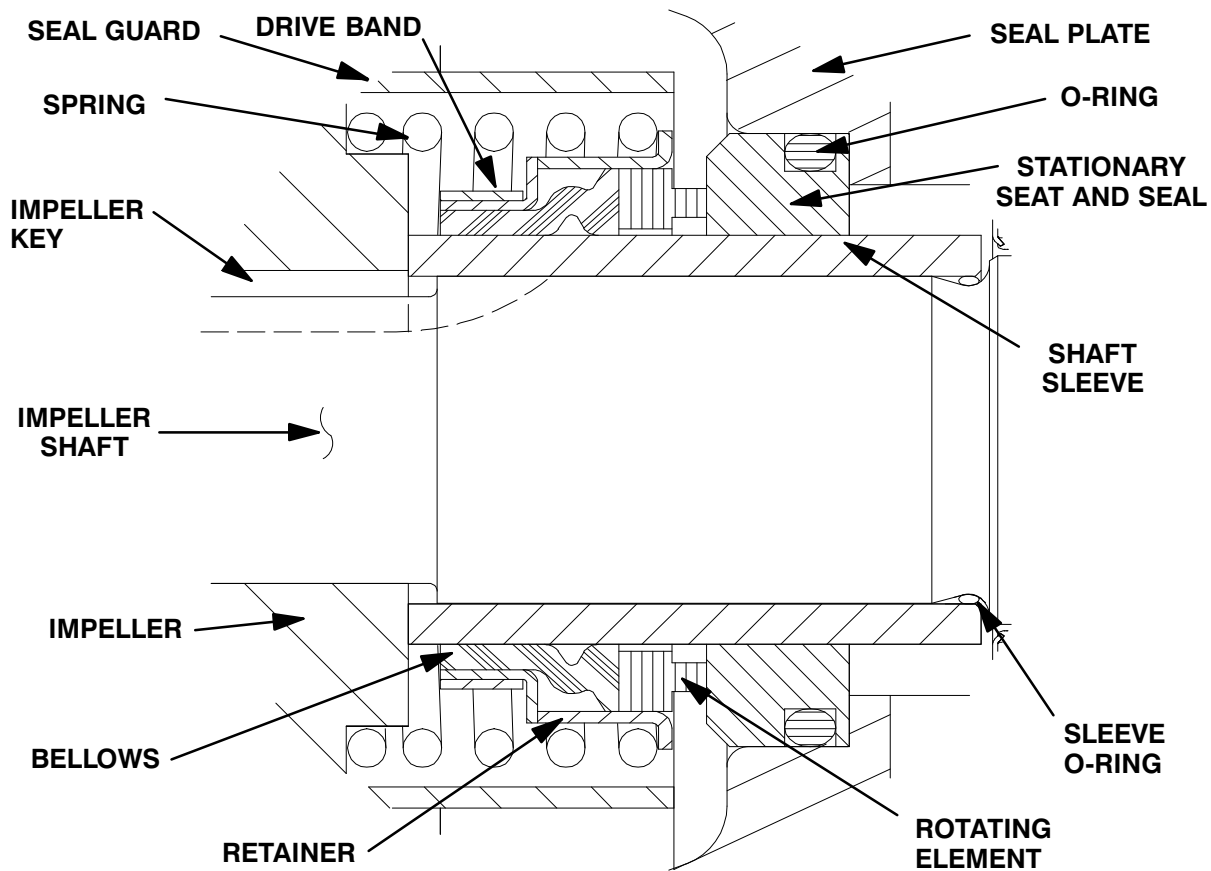

Figure 3. Seal Assembly



This seal is not designed for operation at temperatures above 160°F (71°C). Do not use at higher operating temperatures.

Inspect the pinion shaft (2, Figure 2) for distortion, nicks, scratches, or damage to the shaft keyway. Dress small nicks or burrs with a fine file or emery cloth. If excessive wear exists, refer to **GEARBOX DISASSEMBLY** and replace the shaft.

Lightly lubricate the shaft sleeve O-ring (17) and install it on the shaft.

Lubricate the stationary seat O-ring with light oil and install it in the groove in the seat. Use thumb pressure to press this subassembly into the seal plate until it seats squarely against the shoulder bore. Be careful not to damage the seal face. After installation, wipe the seal face in a concentric pattern with a clean, lint-free cloth to remove any fingerprints.

Subassemble the rotating element into the retainer and bellows, and slide this subassembly over the shaft sleeve until the rotating element is just flush with the chamfered end of the sleeve. Slide the sleeve and rotating portion of the seal onto the shaft until the seal faces contact. Continue to push the sleeve through the seal until the sleeve is fully seated against the shaft shoulder.

Install the seal spring. Make sure that all components of the seal are seated squarely.

Impeller Installation

(Figures 1 and 4)

Inspect the impeller (2), and replace it if cracked or badly worn. If the seal guard (15) was removed, press the replacement guard onto the impeller until it seats squarely against the bore shoulder.



The seal guard **must** seat squarely on the

impeller or binding and/or excessive wear will result.

Align the impeller and key (20) with the shaft keyway, and press the impeller onto the shaft until fully seated. **Be sure** the seal spring seats squarely over the shoulder on the back of the impeller.

NOTE

After the impeller has been installed, check for free rotation. Correct any scraping or binding before further reassembly.

Align the hole in the impeller washer (19) with the key, and install the washer. Immobilize the drive shaft (14, Figure 2), and install the impeller screw and lockwasher (21 and 22). Torque the impeller screw to 20 ft. lbs. (240 in. lbs. or 2,8 m. kg.).

Pump Casing and Wear Ring Installation

(Figure 1)

If the wear ring (24) was removed for replacement,

press the replacement ring into the pump casing until it seats squarely against the shoulder bore.

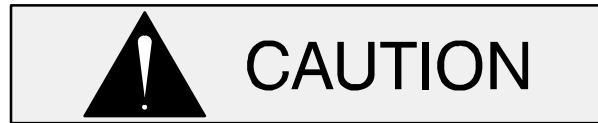

The wear ring **must** seat squarely in the casing bore or binding and/or excessive wear will result.

For maximum pump efficiency, the impeller should be centered within the pump casing. To verify impeller positioning, measure the pump casing and impeller as shown in Figure 4. Use these measurements to calculate the required impeller location (dimension E). Add or remove gaskets in the pump casing gasket set (44) to obtain dimension E.

NOTE

When calculating pump casing positioning, figure 30% compression for pump casing gaskets.

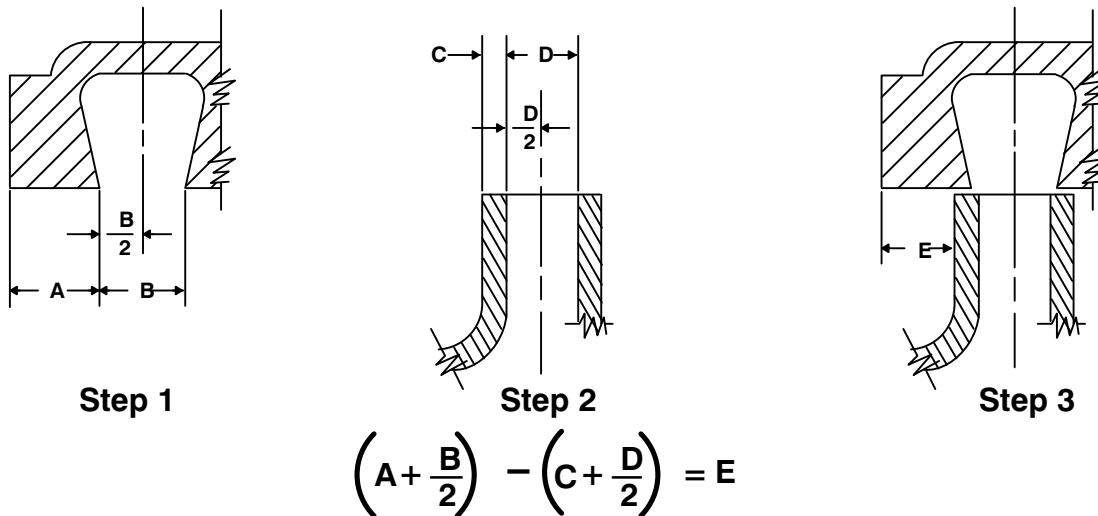

Figure 4. Centering Impeller Within Pump Casing

Install the calculated thickness of pump casing gaskets. Secure the pump casing to the seal plate with the nuts (33).

Reconnect the P.T.O. shaft to the gearbox drive shaft and check the alignment as described in **INSTALLATION**, Section B.

Installing Pump and Gearbox

(Figure 1)

Secure the pump and gearbox to the truck chassis with the previously removed hardware. Be sure to install any leveling shims used under the casing mounting feet.

Install the suction and discharge lines and open all valves. Make certain that all piping connections are tight, properly supported and secure.

Be sure the pump and gearbox have been properly lubricated (see **LUBRICATION**).

Fill the pump casing with clean liquid. Reinstall the fill plug (6) and tighten it.

Refer to **OPERATION**, Section C, before putting the pump back into service.

GEARBOX DISASSEMBLY

(Figure 2)

When the pump is properly operated and maintained, the gearbox should not require disassembly. Disassemble the gearbox **only** when there is evidence of wear or damage.

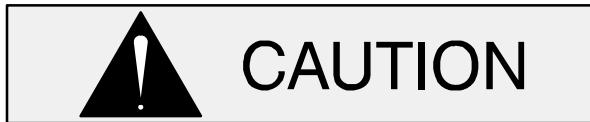

Gearbox disassembly in the field is not recommended. These operations should be performed only in a properly equipped shop by qualified personnel.

If the gearbox requires disassembly, first disassemble the pump components as indicated in **PUMP AND SEAL DISASSEMBLY**.

Before attempting to disassemble the gearbox, remove the lower most pipe plug (23) and drain the lubricant. Clean and reinstall the pipe plug.

With the pump end components removed, use a hammer and punch to drive the dowel pins (31) out of the gearbox. Remove the hardware (28, 29 and 30) securing the seal plate (27) to the gearbox housing (25). Slide the seal plate and oil seal (3) off the shaft. Remove the seal plate gasket (26). Inspect the oil seal (3) and, if replacement is required, press it from the seal plate.

Remove the shaft key (15). Remove the hardware (19 and 20) and slide the cover plate (9) and assembled oil seal (12) off the shaft. Remove the cover plate gasket (8) and bearing adjusting shims (13 and 17). Tie and tag the shims, or measure and record their thickness for ease of reassembly. Inspect the oil seal (12) and, if replacement is required, press it from the cover plate.

Slide the drive shaft (14), bearings (18 and 18A), helical gear (21), pinion shaft (2) and bearings (7 and 7A) out of the seal plate side of the gear housing. It is not necessary to remove the dowel pins (31) unless they are bent or damaged. If replace-

ment is required, remove them from the gear housing.

After removing the shafts and bearings, clean and inspect the bearings **in place** as follows.

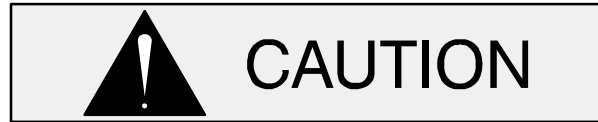

To prevent damage during removal from the shaft, it is recommended that bearings be cleaned and inspected **in place**. It is **strongly** recommended that the bearings be replaced **any** time the shaft and bearings are removed.

Clean the gear housing, seal plate, shafts and all component parts (except the bearings) with a soft cloth soaked in cleaning solvent. Inspect the parts for wear or damage and replace as necessary.



Most cleaning solvents are toxic and flammable. Use them only in a well-ventilated area free from excessive heat, sparks, and flame. Read and follow all precautions printed on solvent containers.

Clean the bearings thoroughly in **fresh** cleaning solvent. Dry the bearings with filtered compressed air and coat with light oil.



Bearings must be kept free of all dirt and foreign material. Failure to do so will greatly shorten bearing life. **Do not** spin dry bearings. This may scratch the balls or races and cause premature bearing failure.

Rotate the bearings by hand to check for roughness or binding and inspect the bearing balls. If rotation is rough or the bearing balls are discolored, replace the bearings.

The bearing tolerances provide a tight press fit onto the shafts and a snug slip fit into the gear housing and seal plate. Replace the bearings,

shafts, gear housing, or seal plate if the proper bearing fit is not achieved.

If the bearings, pinion shaft, or helical drive gear require replacement, use a suitable puller to remove the bearings from the shafts. Slide the spacer (22) and drive gear off the drive shaft. Retain the woodruff key (16).

GEARBOX REASSEMBLY

Clean and inspect the bearings as indicated in **GEARBOX DISASSEMBLY**.



To prevent damage during removal from the shaft, it is recommended that bearings be cleaned and inspected **in place**. It is **strongly** recommended that the bearings be replaced **any** time the shaft and bearings are removed.

Inspect the helical gear (21) and pinion shaft (2) for excessive wear or broken teeth and replace as required.

Install the woodruff key (16) in the shaft keyway, and slide the helical gear onto the shaft. Position the spacer (22) against the inboard side of the helical gear.

The bearings (7, 7A, 18 and 18A) may be heated to ease installation. An induction heater, hot oil bath, electric oven, or hot plate may be used to heat the bearings. Bearings should **never** be heated with a direct flame or directly on a hot plate.

NOTE

*If a hot oil bath is used to heat the bearings, both the oil and the container must be **absolutely** clean. If the oil has been previously used, it must be **thoroughly** filtered.*

Heat the bearings to a uniform temperature **no higher than** 250°F (120°C) and slide them onto the shafts, one at a time, until they are fully seated. This should be done quickly, in one continuous motion, to prevent the bearings from cooling and sticking on the shaft.



Use caution when handling hot bearings to prevent burns.

After the bearings have been installed and allowed to cool, check to ensure that they have not moved out of position in shrinking. If movement has occurred, use a suitably sized sleeve and a press to reposition the bearings.

If heating the bearings is not practical, use a suitably sized sleeve and an arbor (or hydraulic) press to install the bearings onto the shafts.



When installing the bearings onto the shafts, **never** press or hit against the outer race, balls, or ball cage. Press **only** on the inner race.

With the bearings, helical gear and spacer installed on the drive and pinion shafts, mesh the teeth on the helical drive gear with those on the pinion shaft, and slide both shafts into the gear housing (25) until the outboard bearings are seated in the bearing bores of the gear housing.

If the oil seal (3) was removed, apply a light coating of oil to the lip of the replacement seal, and position it in the seal plate (27) with the lip positioned as shown in Figure 2. Press the oil seal into the seal plate until the inner side of the seal is **just flush** with the inside of the seal plate.

Install the seal plate gasket (26) and slide the seal plate over the inboard bearings. Install the cap-screws (28) to align the gearbox halves. Use a hammer and punch to tap the dowel pins (31) into the alignment holes in the gear housing (25) until flush. Use the remaining hardware (29 and 30) to secure the seal plate to the gear housing.

If the oil seal (12) was removed, apply a light coating of oil to the lip of the replacement seal, and position it in the cover plate (9) with the lip positioned as shown in Figure 2. Press the oil seal into the cover plate until the inner side of the seal is **just flush** with the inside of the cover plate.

Position the cover plate gasket (9) against the gear housing. Install the same thickness of bearing ad-

justing shims (13 and 17) as previously removed, and slide the cover plate over the drive shaft.



Use caution not to damage the oil seal lip on the shaft keyway when installing the cover plate.

Apply “Loctite Pipe Sealant With Teflon No. 567” or equivalent compound to the capscrews (20) and secure the cover plate to the gear housing with the hardware (19 and 20).

NOTE

End play for both the drive and pinion shafts should be between .005 to .012 (0,127 to 0,305 mm). Add or remove bearing shims to achieve the correct endplay.

When the shaft end play has been correctly established, remove the bottom three capscrews (20), coat the threads with thread compound, and reinstall them in the gear housing.

Refer to **PUMP AND SEAL REASSEMBLY** and install the remaining pump components. After the pump components are installed, lubricate the gearbox as indicated in **LUBRICATION**.

LUBRICATION

Seal Assembly

(Figure 1)

The seal assembly is lubricated by the medium being pumped and no additional lubrication is required.

Gearbox

(Figures 2 and 5)

The gearbox was fully lubricated when shipped from the factory. Check the oil level regularly at the oil level pipe plug(s) as shown in Figure 5. When lubrication is required, add gear oil through the hole for the air vent (4) the oil level reaches the level shown in the illustration. Clean and reinstall the air vent plug and pipe plug. **Do not** over-lubricate. Over-lubrication can cause the bearings to over-heat, resulting in premature bearing failure.

Change the lubricant in a new gearbox after 100 hours of operation or four weeks, whichever comes first, by draining at operating temperature and thoroughly cleaning with a flushing oil.

After break-in, drain the gearbox after every 500 hours of operation or every six months, whichever comes first, under normal operating conditions. Change the oil more frequently if operated under severe conditions.



Monitor the condition of the bearing lubricant regularly for evidence of rust or moisture condensation. This is especially important in areas where variable hot and cold temperatures are common.

Add 1 ounce (30 ml) of ‘Molykote M’ Gear Guard, then fill with approximately 2 ounces (59 ml) of premium quality, multi-purpose extreme pressure gear lubricant as indicated below.

SAE #80 – Below 40°F (4°C)
 SAE #90 – 40°–100°F (4°–38°C)
 SAE #140 – 100°–150°F (28°–66°C)

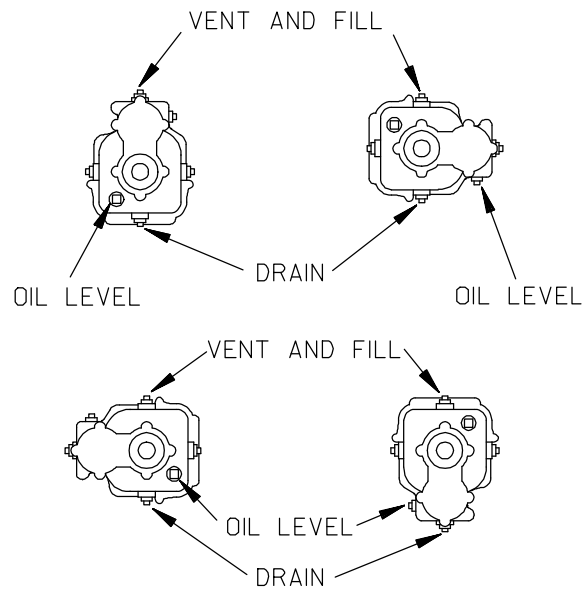

Figure 5. Gearbox Lubrication Positions

**For Warranty Information, Please Visit
www.grpumps.com/warranty
or call:
U.S.: 419-755-1280
Canada: 519-631-2870
International: +1-419-755-1352**

GORMAN-RUPP PUMPS