

---

# **80**SERIES™

---

## **INSTALLATION, OPERATION, PARTS LIST, AND MAINTENANCE MANUAL**

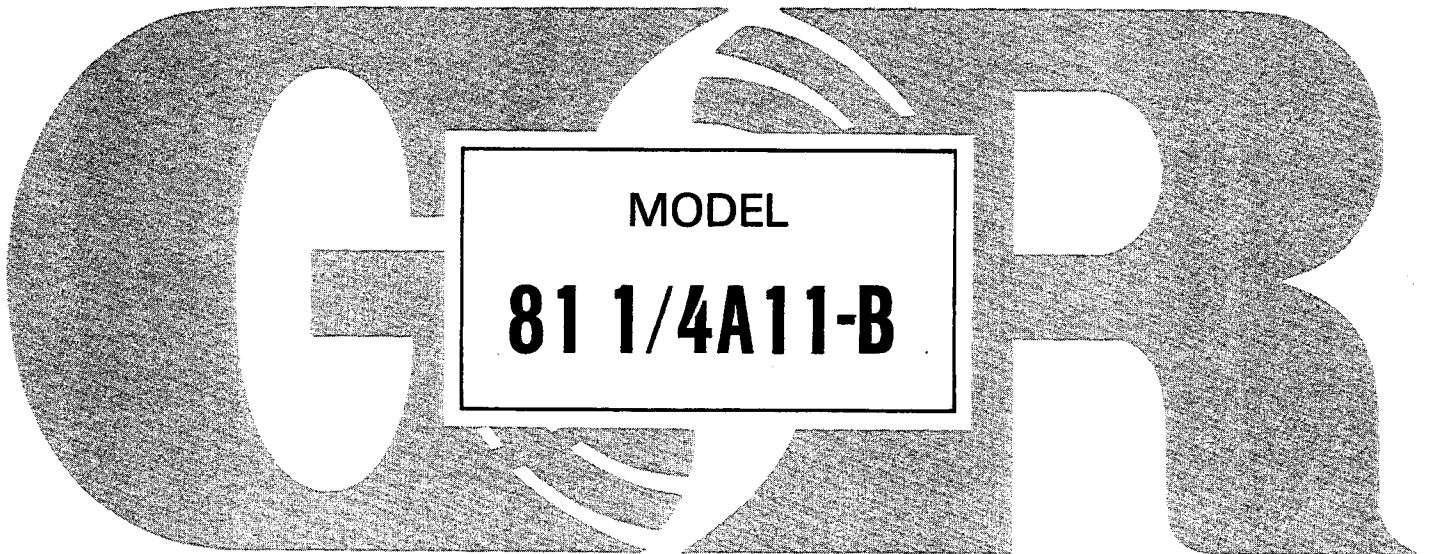

**THE GORMAN-RUPP COMPANY • MANSFIELD, OHIO**

GORMAN-RUPP OF CANADA LIMITED • ST. THOMAS, ONTARIO, CANADA

Printed in U.S.A.

Copyright by the Gorman-Rupp Company



# TABLE OF CONTENTS

INTRODUCTION . . . . .	I-1
WARNINGS - SECTION A . . . . .	A-1
INSTALLATION - SECTION B . . . . .	B-1
Pump Dimensions . . . . .	B-1
PREINSTALLATION INSPECTION . . . . .	B-2
POSITIONING PUMP . . . . .	B-3
Lifting . . . . .	B-3
Mounting . . . . .	B-3
SUCTION AND DISCHARGE PIPING . . . . .	B-4
Materials . . . . .	B-4
Line Configuration . . . . .	B-4
Connections to Pump . . . . .	B-4
Gauges . . . . .	B-4
SUCTION LINES . . . . .	B-4
Fittings . . . . .	B-5
Strainers . . . . .	B-5
Sealing . . . . .	B-5
Suction Lines In Sumps . . . . .	B-5
Suction Line Positioning . . . . .	B-6
DISCHARGE LINES . . . . .	B-6
Siphoning . . . . .	B-6
Valves . . . . .	B-7
Bypass Lines . . . . .	B-7
ALIGNMENT . . . . .	B-7
Coupled Drives . . . . .	B-8
V-Belt Drives . . . . .	B-9
OPERATION - SECTION C . . . . .	C-1
PRIMING . . . . .	C-1
STARTING . . . . .	C-2
Rotation . . . . .	C-2
OPERATION . . . . .	C-2
Lines With a Bypass . . . . .	C-2
Lines Without a Bypass . . . . .	C-3
Leakage . . . . .	C-3
Liquid Temperature And Overheating . . . . .	C-3
Strainer Check . . . . .	C-4
Pump Vacuum Check . . . . .	C-4
STOPPING . . . . .	C-4
Cold Weather Preservation . . . . .	C-4
BEARING TEMPERATURE CHECK . . . . .	C-5
PUMP TROUBLESHOOTING - SECTION D . . . . .	D-1
PUMP MAINTENANCE AND REPAIR - SECTION E . . . . .	E-1
PERFORMANCE CURVE . . . . .	E-1
PUMP MODEL - PARTS LIST . . . . .	E-3
PUMP AND SEAL DISASSEMBLY AND REASSEMBLY . . . . .	E-4
Pump Disassembly . . . . .	E-4
Seal Disassembly . . . . .	E-4
Impeller Shaft And Bearing Disassembly . . . . .	E-5
Impeller Shaft And Bearing Reassembly . . . . .	E-5
Seal Reassembly . . . . .	E-7
Pump Reassembly . . . . .	E-9
LUBRICATION . . . . .	E-10
Seal Assembly . . . . .	E-10
Bearings . . . . .	E-10



INTRODUCTION

This Installation, Operation, and Maintenance Manual is designed to help you achieve the best performance and longest life from your Gorman-Rupp pump.

This pump is an 80 Series, semi-open impeller, self-priming centrifugal model. The pump is design for straight-in suction where the medium being pumped enters directly into the impeller eye. It will handle most non-volatile, non-flammable liquids which contain specified entrained solids. The basic material of construction for wetted parts is gray iron with a bronze impeller and stainless steel impeller shaft.

If there are any questions regarding the pump or its application which are not covered in this manual or in other literature accompanying this unit, please contact your Gorman-Rupp distributor, or write:

The Gorman-Rupp Company	or	Gorman-Rupp of Canada Limited
P.O. Box 1217		70 Burwell Road
Mansfield, Ohio 44901		St. Thomas, Ontario N5P 3R7

For information or technical assistance on the power source, contact the power source manufacturer's local dealer or representative.

The following are used to alert maintenance personnel to procedures which require special attention, to those which could damage equipment, and to those which could be dangerous to personnel:

NOTE

Instructions to aid in installation, operation, and maintenance or which clarify a procedure.

CAUTION

Instructions which must be followed to avoid causing damage to the product or other equipment incidental to the installation. These instructions describe the requirements and the possible damage which could result from failure to follow the procedures.

WARNING

```

////////////////////////////////////
//                               //
// These instructions must be followed to avoid causing in- //
// jury or death to personnel, and describe the procedure //
// required and the injury which could result from failure //
// to follow the procedure. //
//                               //
////////////////////////////////////

```



WARNINGS - SECTION A

THESE WARNINGS APPLY TO 80 SERIES BASIC PUMPS. GORMAN-RUPP HAS NO CONTROL OVER OR PARTICULAR KNOWLEDGE OF THE POWER SOURCE WHICH WILL BE USED. REFER TO THE MANUAL ACCOMPANYING THE POWER SOURCE BEFORE ATTEMPTING TO BEGIN OPERATION.

WARNING

Before attempting to open or service the pump:
1. Familiarize yourself with this manual.
2. Disconnect the power source to ensure that the pump will remain inoperative.
3. Allow the pump to cool if overheated.
4. Vent the pump slowly and cautiously.
5. Close the suction and discharge valves.
6. Check the temperature before opening any covers, plates, or plugs.
7. Drain the pump.

WARNING

This pump is designed to pump most non-volatile, non-flammable liquids which contain specified entrained solids. Do not attempt to pump volatile, corrosive or flammable liquids which may damage the pump or endanger personnel as a result of pump failure.

WARNING

After the pump has been installed, make certain that the pump and all piping connects are secure before operation.

WARNING

Do not operate the pump without shields and/or guards in place over the drive shafts, belts and/or couplings, or other rotating parts. Exposed rotating parts can catch clothing, fingers, or tools, causing severe injury to personnel.

WARNING

```

////////////////////////////////////
//
// Do not operate the pump against a closed discharge valve //
// for long periods of time. This could bring the liquid //
// to a boil, build pressure, and cause the pump to rupture //
// or explode. //
// //
////////////////////////////////////

```

WARNING

```

////////////////////////////////////
//
// Overheated pumps can cause severe burns and injury. If //
// overheating of the pump occurs: //
// //
// 1. Stop the pump immediately. //
// 2. Allow the pump to cool. //
// 3. Refer to instructions in this manual before re- //
// starting the pump. //
// //
////////////////////////////////////

```

WARNING

```

////////////////////////////////////
//
// Do not remove plates, covers, gauges, pipe plugs, or //
// fittings from an overheated pump. Vapor pressure within //
// the pump can cause parts being disengaged to be ejected //
// with great force. Allow the pump to cool before servic- //
// ing. //
// //
////////////////////////////////////

```

WARNING

```

////////////////////////////////////
//
// Never run this pump backwards. Be certain that rotation //
// is correct before fully engaging the pump. //
// //
////////////////////////////////////

```



---

---

## INSTALLATION - SECTION B

Since pump installations are seldom identical, this section offers only general recommendations and practices required to inspect, position, and arrange the pump and piping.

Most of the information pertains to a standard **static lift application** where the pump is positioned above the free level of liquid to be pumped.

If installed in a **flooded suction application** where the liquid is supplied to the pump under pressure, some of the information such as mounting, line configuration, and priming must be tailored to the specific application. Since the pressure supplied to the pump is critical to performance and safety, **be sure** to limit the incoming pressure to 50% of the maximum pressure developed by the pump.

For further assistance, contact your Gorman-Rupp distributor or the Gorman-Rupp Company.

### Pump Dimensions

See Figure 1 for the approximate physical dimensions of this pump.

## OUTLINE DRAWING

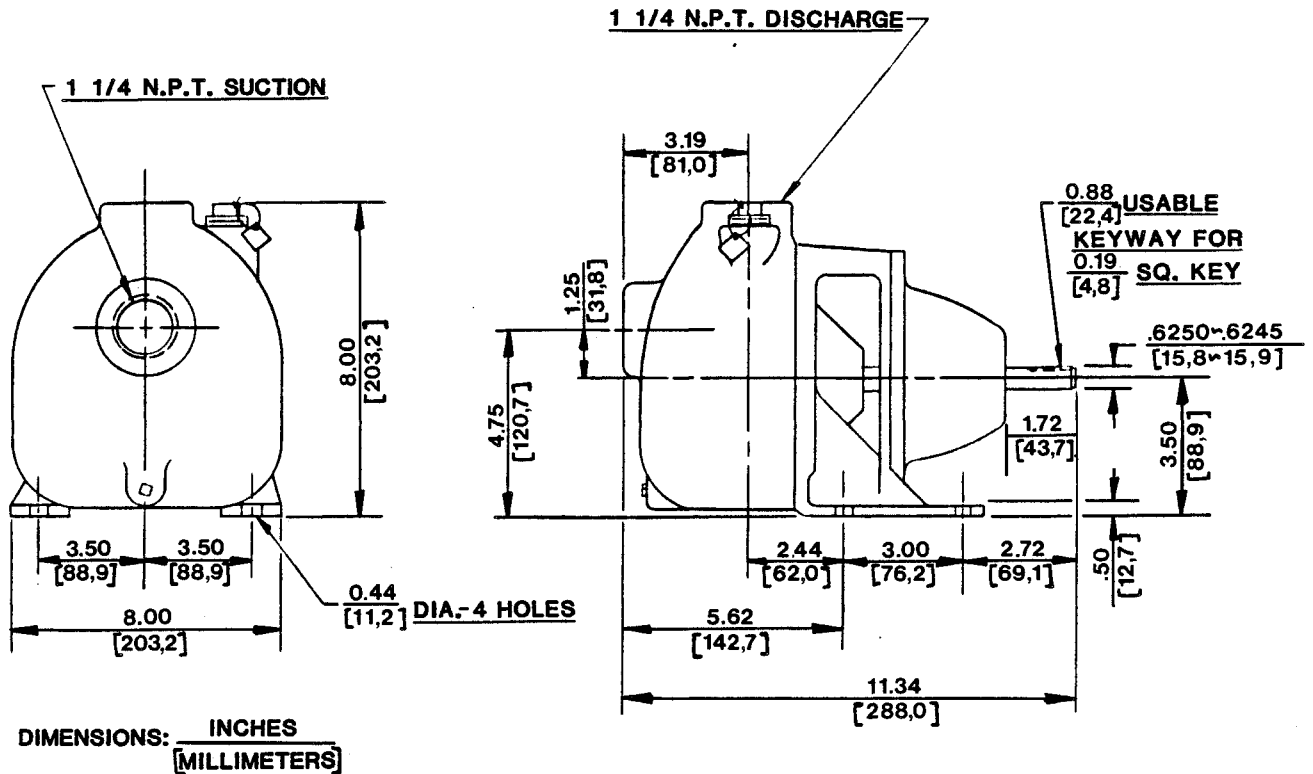

Figure 1. Pump Model 81 1/4A11-B

## PREINSTALLATION INSPECTION

The pump assembly was inspected and tested before shipment from the factory. Before installation, inspect the pump for damage which may have occurred during shipment. Check as follows:

- Inspect the pump for cracks, dents, damaged threads, and other obvious damage.
- Check for and tighten loose bolts, nuts, capscrews, and other attaching hardware. Since gaskets tend to shrink after drying, check for and tighten loose nuts and capscrews securing mating surfaces.
- Carefully read all tags, decals, and markings on the pump assembly, and perform all duties indicated. Note the direction of rotation indicated

---

---

on the pump. Check that the pump shaft rotates in the required direction.

#### CAUTION

Only operate this pump in the direction indicated by the arrow on the pump body and on the accompanying decal. Otherwise, the impeller could become loosened from the shaft and seriously damage the pump.

- d. Check all lubricant levels and lubricate as necessary. Refer to LUBRICATION in the MAINTENANCE AND REPAIR section of this manual and perform duties as instructed.
- e. If the pump and power source have been stored for more than 12 months, some of the components or lubricants may have exceeded their maximum shelf life. These **must be inspected or replaced** to ensure maximum pump service.

If the maximum shelf life has been exceeded, or if anything appears to be abnormal, contact your Gorman-Rupp distributor or the factory to determine the repair or updating policy. **Do not** put the pump into service until appropriate action has been taken.

## POSITIONING PUMP

### Lifting

Use lifting equipment with a capacity of a least **125 pounds**. This pump weighs approximately **25 pounds**, not including the weight of accessories and base and power source.

#### CAUTION

The pump assembly can be seriously damaged if the cables or chains used to lift and move the unit are improperly wrapped around the pump.

### Mounting

Locate the pump in an accessible place as close as practical to the liquid being pumped. Level mounting is essential for proper operation. The pump may have to be supported or shimmed to provide for level operation or to eliminate vibration.

---

---

## SUCTION AND DISCHARGE PIPING

### Materials

Either pipe or hose may be used for suction and discharge lines. Piping materials must be compatible with the liquid being pumped. If hose is used in suction lines, it must be the rigid-wall, reinforced type to prevent collapse under suction. Using piping couplings in suction lines is not recommended.

### Line Configuration

Keep suction and discharge lines as straight as possible to minimize friction losses. Make minimum use of elbows and fittings, which substantially increase friction loss. If elbows are necessary, use the long-radius type to minimize friction loss.

### Connections to Pump

Before tightening a connecting flange, align it exactly with the pump port. Never pull a pipe line into place by tightening the flange bolts and/or couplings.

Lines near the pump must be independently supported to avoid strain on the pump which could cause excessive vibration, decreased bearing life, and increased shaft and seal wear. If hose-type lines are used, they should have adequate support to secure them when filled with liquid and under pressure.

### Gauges

Most pumps are drilled and tapped for installing discharge pressure and vacuum suction gauges. If these gauges are desired for pumps that are not tapped, drill and tap the suction and discharge lines close to the pump before installing the lines.

## SUCTION LINES

To avoid air pockets which could affect pump priming, the suction line must be as short and direct as possible. When operation involves a suction lift, the line must always slope upward to the pump from the source of the liquid being pumped; if the line slopes down to the pump at any point along the suction run, air pockets will be created.

---

---

## Fittings

Suction lines should be the same size as the pump inlet. If reducers are used in suction lines, they should be the eccentric type, and should be installed with the flat part of the reducers uppermost to avoid creating air pockets. Valves are not normally used in suction lines, but if a valve is used, install it with the stem horizontal to avoid air pockets.

## Strainers

If a strainer is furnished with the pump, be certain to use it; any spherical solids which pass through a strainer furnished with the pump will also pass through the pump itself.

If a strainer is not furnished with the pump, but is installed by the pump user, make certain that the total area of the openings in the strainer is at least three or four times the cross section of the suction line, and that the openings will not permit passage of solids larger than the solids handling capability of the pump.

This pump is designed to handle up to 1/4 inch diameter spherical solids.

## Sealing

Since even a slight leak will affect priming, head, and capacity, especially when operating with a high suction lift, all connections in the suction line should be sealed with pipe dope to ensure an airtight seal. Follow the sealant manufacturer's recommendations when selecting and applying the pipe dope. The pipe dope should be compatible with the liquid being pumped.

## Suction Lines In Sumps

If a single suction line is installed in a sump, it should be positioned away from the wall of the sump at a distance equal to one and one-half times the diameter of the suction line.

If there is a liquid flow from an open pipe into the sump, the flow should be kept away from the suction inlet because the inflow will carry air down into the sump, and air entering the suction line will reduce pump efficiency.

If it is necessary to position inflow close to the suction inlet, install a baffle between the inflow and the suction inlet at a distance one and one-half times the diameter of the suction pipe. The baffle will allow entrained air to escape from the liquid before it is drawn into the suction inlet.

If two suction lines are installed in a single sump, the flow paths may interact, reducing the efficiency of one or both pumps. To avoid this, position the suction inlets so that they are separated by a distance equal to at least three times the diameter of the suction pipe.

### Suction Line Positioning

The depth of submergence of the suction line is critical to efficient pump operation. Figure 2 shows recommended minimum submergence vs. velocity.

#### NOTE

The pipe submergence required may be reduced by installing a standard pipe increaser fitting at the end of the suction line. The larger opening size will reduce the inlet velocity. Calculate the required submergence using the following formula based on the increased opening size (area or diameter).

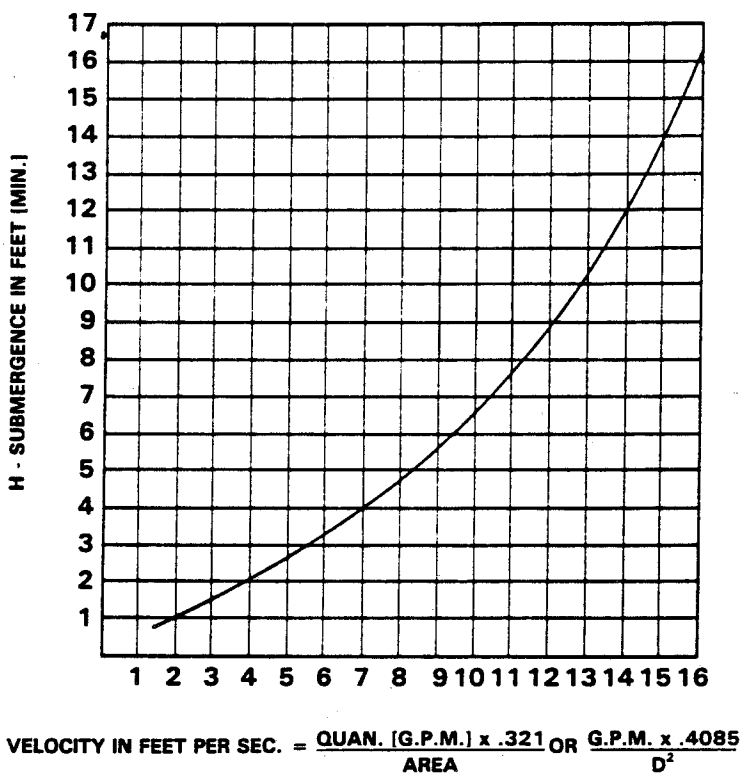

Figure 2. Recommended Minimum Suction Line Submergence Vs. Velocity

### DISCHARGE LINES

#### Siphoning

Do not terminate the discharge line at a level lower than that of the liquid being pumped unless a siphon breaker is used in the line. Otherwise, a siphoning action causing damage to the pump could result.

---

---

## Valves

If a throttling valve is desired in the discharge line, use a valve as large as the largest pipe in the line to minimize friction losses. Never install a throttling valve in a suction line.

A check valve in the discharge line is normally recommended, but is not necessary in low discharge head applications.

With high discharge heads, it is recommended that a throttling valve and a check valve be installed in the discharge line to protect the pump from excessive shock pressure and reverse rotation when it is stopped.

## Bypass Lines

If it is necessary to permit the escape of air to atmosphere during initial priming or in the repriming cycle, install a bypass line between the pump and the discharge check valve. The bypass line should be sized so that it does not affect pump discharge capacity.

Either a Gorman-Rupp automatic air release valve - which will automatically open to allow the pump to prime, and automatically close when priming is accomplished - or a hand-operated shutoff valve should be installed in the bypass line.

### NOTE

The bypass line may clog frequently, particularly if the valve remains closed. If this condition occurs, either use a larger bypass line or leave the shutoff valve open during the pumping operation.

Do not terminate the discharge line at a level lower than that of the liquid being pumped unless a siphon breaker is used in the line. Otherwise, a siphoning action could result, causing damage to the pump.

## ALIGNMENT

The alignment of the pump and its power source is critical for trouble-free mechanical operation. In either a flexible coupling or V-belt driven system, the driver and pump must be mounted so that their shafts are aligned with and parallel to each other. It is imperative that alignment be checked after the pump is installed, and before operation.

### NOTE

Check **Rotation**, Section C, before final alignment of the pump.

INSTALLATION

When mounted at the Gorman-Rupp factory, driver and pump are aligned before shipment. Misalignment can occur in transit and handling. Pumps should be checked, and realigned if necessary, before being put into operation. Before checking alignment, tighten the foundation bolts. The pump casing feet and/or pedestal feet, and the driver mounting bolts should also be tightly secured.

**WARNING**

```

////////////////////////////////////
//                               //
// When checking alignment, disconnect the power source to //
// ensure that the pump will remain inoperative.           //
//                                                           //
////////////////////////////////////

```

**CAUTION**

Adjusting the alignment in one direction may alter the alignment in another direction. Check each procedure after altering alignment.

**Coupled Drives**

When using couplings, the axis of the power source must be aligned to the axis of the pump shaft in both the horizontal and vertical planes. Most couplings require a specific gap or clearance between the driving and the driven shafts. Refer to the coupling manufacturer's service literature.

Align spider insert type couplings by using calipers to measure the dimensions on the circumference of the outer ends of the coupling hub every 90 degrees. The coupling is in alignment when the hub ends are the same distance apart at all points (see Figure 3A).

Align non-spider type couplings by using a feeler gauge or taper gauge between the coupling halves every 90 degrees. The coupling is in alignment when the hubs are the same distance apart at all points (see Figure 3B).

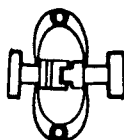

**Figure 3A. Aligning Spider-Type Couplings**





Figure 3B. Aligning Non-Spider Type Couplings

Check parallel adjustment by laying a straightedge across both coupling rims at the top, bottom, and side. When the straightedge rests evenly on both halves of the coupling, the coupling is in horizontal parallel alignment. If the coupling is misaligned, use a feeler gauge between the coupling and the straightedge to measure the amount of misalignment.

### V-Belt Drives

When using V-belt drives, the power source and the pump must be parallel. Use a straightedge along the sides of the pulleys to ensure that the pulleys are properly aligned (see Figure 3C). In drive systems using two or more belts, make certain that the belts are a matched set; unmatched sets will cause accelerated belt wear.

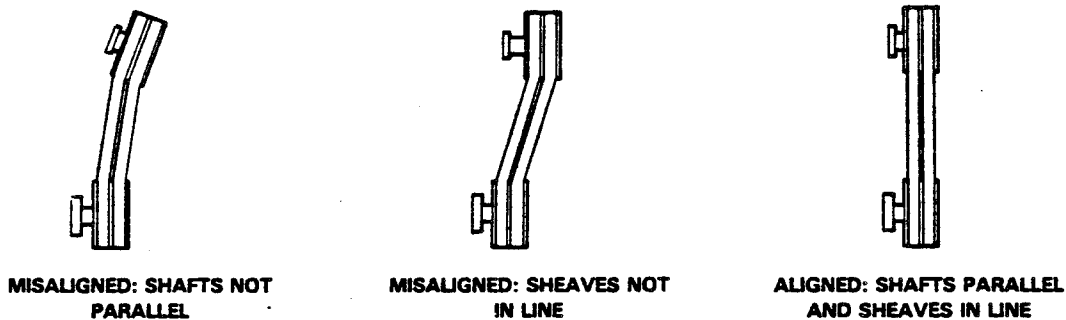

Figure 3C. Alignment of V-Belt Driven Pumps

Tighten the belts in accordance with the belt manufacturer's instructions. If the belts are too loose, they will slip; if the belts are too tight, there will be excessive power loss and possible bearing failure. Select pulleys that will match the proper speed ratio; overspeeding the pump may damage both pump and power source.

---

---

**WARNING**

////////////////////////////////////  
//  
// Do not operate the pump without a guard over the rotat- //  
// ing parts. Exposed rotating parts can catch clothing, //  
// fingers, or tools, causing severe injury to personnel. //  
//  
////////////////////////////////////

OPERATION

OPERATION - SECTION C

WARNING

```

////////////////////////////////////
//
// Do not attempt to pump volatile, corrosive, or flammable //
// materials, or any liquids for which this pump has not //
// been designed. //
// //
////////////////////////////////////

```

CAUTION

Pump speed and operating condition points must be within the continuous performance range shown on the curve. See Section E, Page 1.

PRIMING

Install the pump and piping as described in INSTALLATION. Make sure that the piping connections are tight, and that the pump is securely mounted. Check that the pump is properly lubricated (see LUBRICATION in MAINTENANCE AND REPAIR).

This pump is self-priming, but the pump should never be operated unless there is liquid in the casing.

CAUTION

Never operate a self-priming pump unless there is liquid in the casing. The pump will not prime when dry. Extended operation of a dry pump will destroy the seal assembly.

Add liquid to the pump casing when:

1. The pump is being put into service for the first time.
2. The pump has not been used for a considerable length of time.
3. The liquid in the pump casing has evaporated.

Once the pump casing has been filled, the pump will prime and reprime as necessary.

OPERATION

WARNING

```

////////////////////////////////////
//
// After filling the pump casing, reinstall and tighten the //
// fill plug. Do not attempt to operate the pump unless //
// all connecting piping is securely installed. Otherwise, //
// liquid in the pump forced out under pressure could cause //
// injury to personnel. //
// //
////////////////////////////////////

```

To fill the pump, remove the pump casing fill cover or fill plug at the top of the casing and add clean liquid until the pump is filled. Replace the fill cover or fill plug before operating the pump.

STARTING

Consult the operations manual furnished with the power source.

Rotation

The correct direction of pump rotation is indicated by an arrow on the pump body and on the accompanying decal. If the pump is operated in the wrong direction, the impeller could become loosened from the shaft and seriously damage the pump.

CAUTION

Only operate this pump in the direction indicated by the arrow on the pump body and on the accompanying decal. Otherwise, the impeller could become loosened from the shaft and seriously damage the pump.

Consult the operating manual furnished with the pump power source before attempting to start the power source.

If the rotation of a three-phase electric motor is incorrect, have qualified personnel interchange any two of the three-phase wires to change direction.

OPERATION

Lines With a Bypass

Either a Gorman-Rupp automatic air release valve or a hand operated shutoff valve may be installed in a bypass line.

---

---

If a Gorman-Rupp automatic air release valve has been installed, close the throttling valve in the discharge line. The Gorman-Rupp valve will automatically open to allow the pump to prime, and automatically close when priming has been accomplished. After the pump has been primed, and liquid is flowing steadily from the bypass line, open the discharge throttling valve.

If a hand operated shutoff valve has been installed, close the throttling valve in the discharge line, and open the bypass shutoff valve so that the pump will not have to prime against the weight of the liquid in the discharge line. When the pump has been primed, and liquid is flowing steadily from the bypass line, close the bypass shutoff valve and open the discharge throttling valve.

### Lines Without a Bypass

Open all valves in the discharge line and start the power source. Priming is indicated by a positive reading on the discharge pressure gauge or by a quieter operation. The pump may not prime immediately because the suction line must first fill with liquid. If the pump fails to prime within five minutes, stop it and check the suction line for leaks.

After the pump has been primed, partially close the discharge line throttling valve in order to fill the line slowly and guard against excessive shock pressure which could damage pipe ends, gaskets, sprinkler heads, and any other fixtures connected to the line. When the discharge line is completely filled, adjust the throttling valve to the required flow rate.

### Leakage

No leakage should be visible at pump mating surfaces, or at pump connections or fittings. Keep all line connections and fittings tight to maintain maximum pump efficiency.

### Liquid Temperature And Overheating

The **maximum** liquid temperature for this pump is 160° F. Do not apply it at a higher operating temperature.

Overheating can occur if the valves in the suction or discharge lines are closed. Operating against closed valves could bring the liquid to a boil, build pressure, and cause the pump to rupture or explode. If overheating occurs, stop the pump and allow it to cool before servicing it. Refill the pump casing with cool liquid.

OPERATION

WARNING

```

////////////////////////////////////
//
// Do not remove plates, covers, gauges, pipe plugs, or //
// fittings from an overheated pump. Vapor pressure within //
// the pump can cause parts being disengaged to be ejected //
// with great force. Allow the pump to cool before servic- //
// ing. //
// //
////////////////////////////////////

```

Strainer Check

If a suction strainer has been shipped with the pump or installed by the user, check the strainer regularly, and clean it as necessary. The strainer should also be checked if pump flow rate begins to drop.

Pump Vacuum Check

Since this pump does not have a suction check valve, the discharge line must be fitted with a check valve if a pump vacuum reading is to be taken.

With the pump inoperative, install a vacuum gauge in the system, using pipe dope on the threads. Block the suction line and start the pump. At operating speed the pump should pull a vacuum of 20 inches or more of mercury. If it does not, check for air leaks in the seal, gasket, or discharge valve.

Open the suction line, and read the vacuum gauge with the pump primed and at operation speed. Shut off the pump. The vacuum gauge reading will immediately drop proportionate to static suction lift, and should then stabilize. If the vacuum reading falls off rapidly after stabilization, an air leak exists. Before checking for the source of the leak, check the point of installation of the vacuum gauge.

STOPPING

Never halt the flow of liquid suddenly. If the liquid being pumped is stopped abruptly, damaging shock waves can be transmitted to the pump and piping system. Close all connecting valves slowly.

After stopping the pump, disconnect the power source to ensure that the pump will remain inoperative.

Cold Weather Preservation

In below freezing conditions, drain the pump to prevent damage from freezing. Also, clean out any solids by flushing with a hose. Operate the pump for approx-

---

---

## OPERATION

---

---

imately one minute; this will remove any remaining liquid that could freeze the pump rotating parts.

If the pump will be idle for more than a few hours, or if it has been pumping liquids containing a large amount of solids, drain the pump, and flush it thoroughly with clean water. To prevent large solids from clogging the drain port and preventing the pump from completely draining, insert a rod or stiff wire in the drain port, and agitate the liquid during the draining process. Clean out any remaining solids by flushing with a hose.

### BEARING TEMPERATURE CHECK

Bearings normally run at higher than ambient temperatures because of heat generated by friction. Temperatures up to 160°F are considered normal for bearings, and they can operate safely to at least 180°F.

Checking bearing temperatures by hand is inaccurate. Bearing temperatures can be measured accurately by placing a contact-type thermometer against the housing. Record this temperature for future reference.

A sudden increase in bearing temperatures is a warning that the bearings are at the point of failing to operate properly. Make certain that the bearing lubricant is of the proper viscosity and at the correct level (see LUBRICATION in MAINTENANCE AND REPAIR). Bearing overheating can also be caused by shaft misalignment and/or excessive vibration.

When pumps are first started, the bearings may seem to run at temperatures above normal. Continued operation should bring the temperatures down to normal levels.





PUMP TROUBLESHOOTING - SECTION D

WARNING

```

////////////////////////////////////
//
// Before attempting to open or service the pump:
//
// 1. Familiarize yourself with this manual.
// 2. Disconnect the power source to ensure that the
//    pump will remain inoperative.
// 3. Allow the pump to cool if overheated.
// 4. Vent the pump slowly and cautiously.
// 5. Close the suction and discharge valves.
// 6. Check the temperature before opening any covers,
//    plates, or plugs.
// 7. Drain the pump.
//
////////////////////////////////////
    
```

TROUBLE	POSSIBLE CAUSE	PROBABLE REMEDY
PUMP FAILS TO PRIME	Air leak in suction line.	Correct leak.
	Lining of suction hose collapsed.	Replace suction hose.
	Leaking or worn seal or pump gasket.	Check pump vacuum. Replace leaking or worn seal or gasket.
	Suction lift or discharge head too high.	Check piping installation and install bypass line if needed. See INSTALLATION.
	Strainer clogged.	Check strainer and clean if necessary.
	Suction check valve or foot valve clogged or binding.	Clean valve.
PUMP STOPS OR FAILS TO DELIVER RATED FLOW OR PRES-SURE	Air leak in suction line.	Correct leak.
	Suction intake not submerged at proper level or sump too small.	Check installation and correct as needed. Check submergence chart (Section B).
	Lining of suction hose collapsed.	Replace suction hose.
	Impeller or other wearing parts worn or damaged.	Replace worn or damaged parts. Check that impeller is properly centered and rotates freely.

TROUBLE	POSSIBLE CAUSE	PROBABLE REMEDY
PUMP STOPS OR FAILS TO DELIVER RATED FLOW OR PRESSURE(cont.)	<p>Impeller clogged.</p> <p>Pump speed too slow.</p> <p>Discharge head too high.</p> <p>Suction lift too high.</p> <p>Leaking or worn seal or pump gasket.</p> <p>Strainer clogged.</p>	<p>Free impeller of debris.</p> <p>Check driver output; check belts or couplings for slippage.</p> <p>Install bypass line.</p> <p>Reduce suction lift.</p> <p>Check pump vacuum. Replace leaking or worn seal or gasket.</p> <p>Check strainer and clean if necessary.</p>
PUMP REQUIRES TOO MUCH POWER	<p>Pump speed too high.</p> <p>Discharge head too low.</p> <p>Liquid solution too thick.</p>	<p>Check driver output; check that sheaves or couplings are correctly sized.</p> <p>Adjust discharge valve.</p> <p>Dilute if possible.</p>
PUMP CLOGS FREQUENTLY	<p>Discharge flow too slow.</p> <p>Suction check valve or foot valve clogged or binding.</p>	<p>Open discharge valve fully to increase flow rate, and run power source at maximum governed speed.</p> <p>Clean valve.</p>
EXCESSIVE NOISE	<p>Cavitation in pump.</p> <p>Pumping entrained air.</p> <p>Pump or drive not securely mounted.</p> <p>Impeller clogged or damaged.</p>	<p>Reduce suction lift and/or friction losses in suction line.</p> <p>Locate and eliminate source of air bubble.</p> <p>Secure mounting hardware.</p> <p>Clean out debris; replace damaged parts.</p>

---

---

---

TROUBLE	POSSIBLE CAUSE	PROBABLE REMEDY
BEARINGS RUN TOO HOT	Bearing temperature is high, but within limits.  Suction and discharge lines not properly supported.  Drive misaligned.	Check bearing temperature regularly to monitor any increase.  Check piping installation for proper support.  Align drive properly.



PUMP MAINTENANCE AND REPAIR - SECTION E

MAINTENANCE AND REPAIR OF THE WEARING PARTS OF THE PUMP WILL MAINTAIN PEAK OPERATING PERFORMANCE.

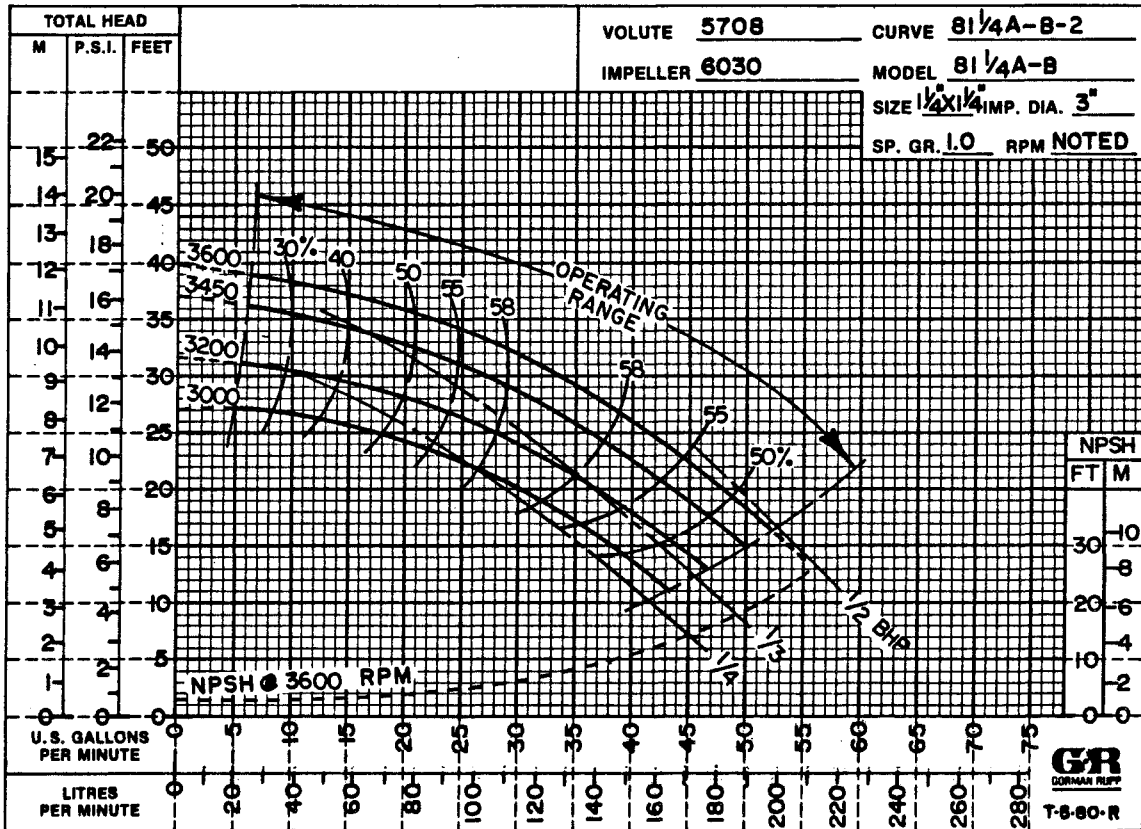

\*STANDARD PERFORMANCE FOR PUMP MODEL 81 1/4A11-B

\*Based on 70°F clear water at sea level with minimum suction lift. Since pump installations are seldom identical, your performance may be different due to such factors as viscosity, specific gravity, elevation, temperature, and impeller trim.

If your pump serial number is followed by an "N", your pump is NOT a standard production model. Contact the Gorman-Rupp Company to verify performance or part numbers.

CAUTION

Pump speed and operating condition points must be within the continuous performance range shown on the curve. See Section E, Page 1.

SECTIONAL DRAWING

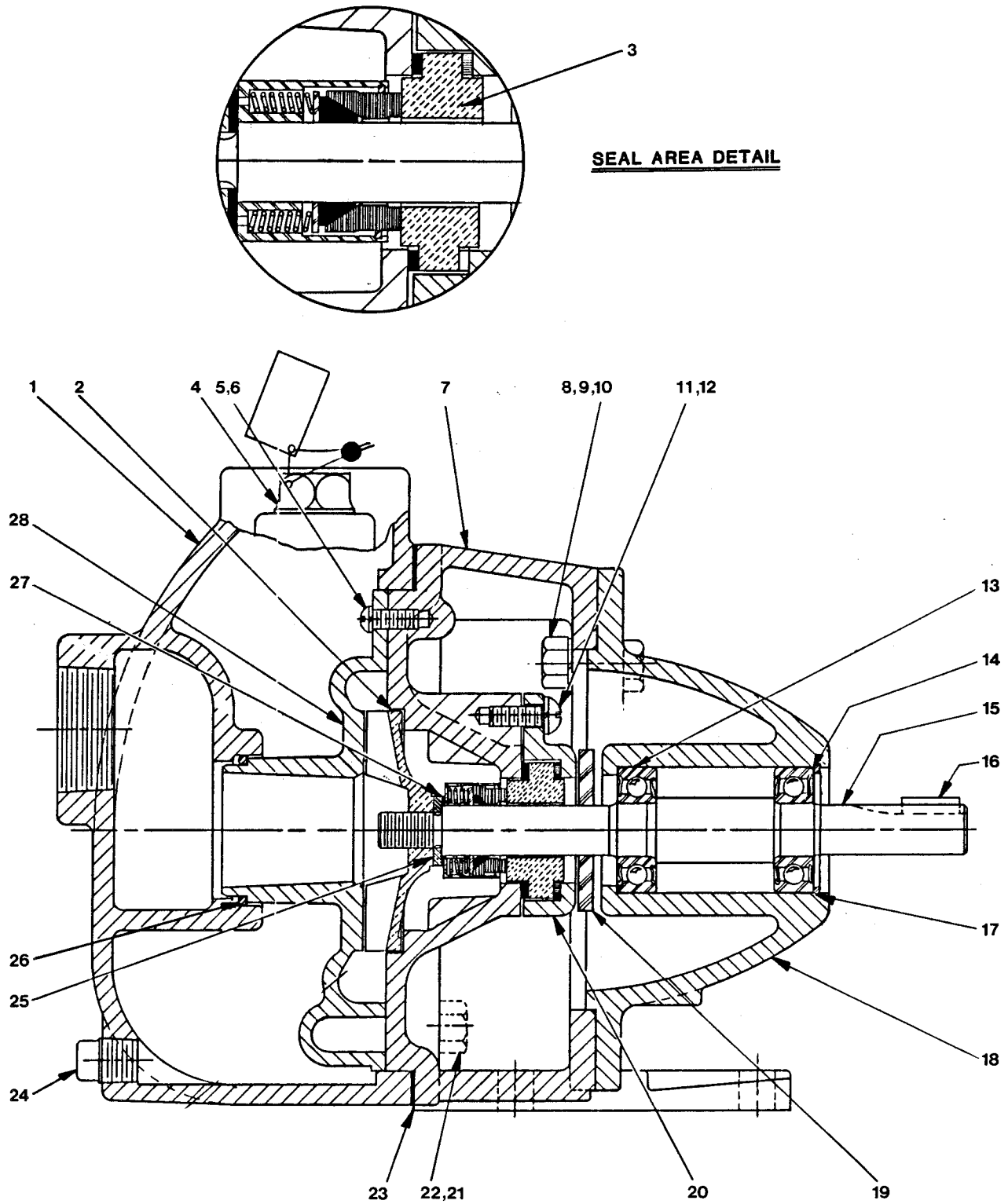

Figure 1. Pump Model 81 1/4A11-B

PARTS LIST  
 Model 81 1/4A11-B  
 (From S/N 794462 up)

ITEM NO.	PART NAME	PART NUMBER	MATL CODE	QTY
1	PUMP CASING	5709	10010	1
2	* IMPELLER	6030	14010	1
3	* SEAL ASSY	S01219	-----	1
4	FILL PLUG ASSY	48271-060	-----	1
5	ROUND HD MACHINE SCREW	X#10-02	14990	2
6	LOCKWASHER	J#00010	15991	2
7	INTERMEDIATE	5711-A	10010	1
8	HEX HD CAPSCREW	B00605	15991	4
9	LOCKWASHER	J00006	15991	4
10	HEX NUT	D00006	15991	4
11	ROUND HD MACHINE SCREW	X00403	15991	3
12	LOCKWASHER	J00004	15991	3
13	* BEARING	S00528	-----	2
14	* BEARING ADJUSTING SHIM SET	2-X	17090	1
15	IMPELLER SHAFT	10673-A	17130	1
16	* KEY	N00303	15990	1
17	RETAINING RING	S00494	-----	1
18	PEDESTAL	10671	10010	1
19	* SLINGER RING	31131-062	19330	1
20	SEAL CAP	7166	10010	1
21	STUD	C00605	15991	4
22	HEX NUT	D00006	15991	4
23	* GASKET	5709-GB	19250	1
24	DRAIN PLUG	P00004	11990	1
25	* SEAL WASHER	6087	14110	1
26	* O-RING	S01616	-----	1
27	* IMPELLER ADJUSTING SHIM SET	5889	17000	1
28	VANE PLATE	38632-515	10010	1
NOT SHOWN:				
	NAME PLATE	2613-A	13990	1
	DRIVE SCREW	BM#04-03	15991	4
	ROTATION DECAL	2613-CU	00000	1

\*INDICATES PARTS RECOMMENDED FOR STOCK

Above Serial Numbers Do Not Apply To Pumps Made In Canada.

CANADIAN SERIAL NO. .... AND UP

MAINTENANCE AND REPAIR

PUMP AND SEAL DISASSEMBLY AND REASSEMBLY

This pump requires little service due to its rugged, minimum-maintenance design. However, if it becomes necessary to inspect or replace the wearing parts, follow these instructions, which are keyed to the sectional views (see Figure 1 and 2) and the accompanying parts list.

WARNING

```

////////////////////////////////////
//
// Before attempting to open or service the pump:
//
// 1. Familiarize yourself with this manual.
// 2. Disconnect the power source to ensure that the
// pump will remain inoperative.
// 3. Allow the pump to cool if overheated.
// 4. Vent the pump slowly and cautiously.
// 5. Close the suction and discharge valves.
// 6. Check the temperature before opening any covers,
// plates, or plugs.
// 7. Drain the pump.
//
////////////////////////////////////

```

Pump Disassembly

(Figure 1)

Disconnect the power source, making certain that it will remain inoperative while the pump is being serviced, and close all connecting valves. Remove the casing drain plug (24) to drain the pump. Clean and reinstall the drain plug.

Remove the nuts (22) securing the pump casing (1) to the intermediate (7). Separate the assemblies, and separate the vane plate (28) from the intermediate by removing the machine screws and lockwashers (5 and 6).

To loosen the impeller (2), immobilize it by placing a block of wood between the vanes. Install a lathe dog on the drive end of the shaft and turn it in a clockwise direction (as viewed from the drive end). Unscrew the impeller, and replace it if cracked or badly worn.

Remove the impeller adjusting shims (27) and seal washer (25). For ease of re-assembly, tag and tie the shims, or measure and record their thickness.

Seal Disassembly

(Figure 1 and 2)

Three setscrews around the circumference of the seal retainer secure the seal assembly to the shaft and ensure proper seal spring tension. If the old seal assembly will be reused, **do not loosen these setscrews** before measuring the distance between the impeller end of the seal retainer and the face of the stationary seal seat. This measurement is critical.



---

---

Loosen the setscrews, using an allen wrench. (Clearance between the seal retainer and the intermediate is limited, and it may be necessary to grind down the head of the wrench.) Slide the seal - with the exception of the stationary seal seat and gaskets - off the shaft, using a wire with a hooked end if necessary.

Remove the capscrews, lockwashers and nuts (8, 9, and 10) securing the intermediate to the pedestal (18), and slide the intermediate, stationary seal seat, and seal cap (20) off the shaft.

To remove the stationary seat and gaskets, remove the machine screws and washers (11 and 12) securing the seal cap to the intermediate. Remove the seal cap, and set aside the stationary seat and washers.

### Impeller Shaft And Bearing Disassembly

#### (Figure 1)

When the pump is properly operated and maintained, the pedestal should not require disassembly. Disassemble the shaft and bearings **only** when there is evidence of wear or damage.

#### CAUTION

Shaft and bearing disassembly in the field is not recommended. These operations should be performed only in a properly-equipped shop by qualified personnel.

Remove the shaft key (16) and the retaining ring (17) from the drive end of the shaft and slide the bearing adjustment shims (14) off. For ease of reassembly, tag and tie the shims or measure and record their thickness.

Remove the slinger ring (19) from the impeller shaft (15) and press the impeller shaft and bearings (14) from the pedestal (18). The inboard bearing should come free with the shaft. If it does not, press it out of the pedestal cavity with a bearing puller or arbor press.

### Impeller Shaft And Bearing Reassembly

#### (Figure 1)

Clean the impeller shaft, pedestal cavity and all component parts (except bearings) with a soft cloth soaked in cleaning solvent, and dry thoroughly.

**WARNING**

```

////////////////////////////////////
//
// Most cleaning solvents are toxic and flammable. Use //
// them only in a well-ventilated area free from excessive //
// heat, sparks, and flame. Read and follow all prec- //
// autions printed on solvent containers. //
//
////////////////////////////////////

```

Inspect the shaft for damaged threads, distortion, or nicks and scratches. Dress small nicks and burrs with a fine file or honing stone. Replace the impeller shaft if severely damaged.

To prevent contamination, wash the bearings separately in **fresh** cleaning solvent. Dry the bearings with filtered compressed air and coat with light oil for ease of reassembly.

Rotate the bearings by hand to check for roughness or binding. If rotation is rough, replace the bearings.

**CAUTION**

These bearings are permanently sealed and require no additional lubrication except a coating of light oil on external surfaces to ease reassembly. These external surfaces must be kept free of all dirt and foreign material. Failure to do so could damage the bearings or their mating surfaces.

The bearing tolerances provide a light press onto the impeller shaft, and a snug push fit into the pedestal. If the bearings slip on and off easily, the shaft is worn and must be replaced. The pedestal must be replaced if the bearings do not fit snugly.

Inspect the pedestal for cracks, especially around the mounting flange and at the foot. Remove nicks and burrs from the bearing seating surfaces with extra fine emery cloth or a fine stone.

Dip the bearings in clean oil and then position them on the shaft. Using an arbor press, press against the inner races until the bearings seat squarely against the shaft shoulders.

**CAUTION**

When installing the bearings onto the shaft, NEVER press or hit against the outer race, balls, or ball cage. Press ONLY on the inner race.

Push the shaft and assembled bearings into the pedestal until the inboard bearing bottoms against the pedestal cavity.

CAUTION

When installing the shaft and bearings into the pedestal, push against the outer race. NEVER hit the balls or ball cage.

Install the same thickness of bearing shims as previously removed at disassembly, and install the retainer snap ring. Use a soft-faced mallet to drive the shaft toward the impeller end of the pump and check the shaft end play.

NOTE

The shaft end play should be between .002 to .010 inch. Add or subtract shims (14) until within specified limits.

Position the slinger ring on the shaft about 1/2 inch from the pedestal and reinstall the shaft key. These bearings are permanently sealed and require no additional lubrication.

Seal Reassembly

(Figure 2)

Clean the intermediate cavity, seal cap, and the impeller shaft with a soft cloth soaked in cleaning solvent.

WARNING

Most cleaning solvents are toxic and flammable. Use them only in a well-ventilated area free from excessive heat, sparks, and flame. Read and follow all precautions printed on solvent containers.

The seal is not normally reused since any damage to the precision finished faces could result in premature seal failure. If it is necessary to reuse the old seal in an emergency, carefully wash all metallic parts in fresh cleaning solvent and allow them to dry thoroughly.

NOTE

Do not remove the snap ring from the inside diameter of the seal retainer. Complete disassembly of the rotating portion of the seal is not recommended.

Inspect the seal components for wear, scoring, grooves, or other damage which might cause leakage. If any components are worn, replace the complete seal; never mix old and new seal parts. Handle the seal parts with extreme care to

prevent damage. Be careful not to contaminate the precision finished faces, even finger prints on the faces can shorten seal life.

See Figure 2 for the correct order of installation of seal components.

If the old seal assembly is being used, install the stationary seat and gaskets into the seal cap and secure to the intermediate. Reinstall the slinger ring, position the intermediate on the shaft and secure with the hardware previously removed.

Lubricate the wedge and disc with soft grease or oil, and slide the balance of the old seal assembly on the shaft. Make certain that the rotating assembly bottoms squarely against the stationary seat. Compress the spring, and position the seal on the shaft so that there is the same distance between the impeller end of the seal retainer and the stationary seat as there was before the setscrews were loosened. The designed working length of the seal is  $\frac{3}{4}$  inch. When this distance has been accurately established, tighten the setscrews.

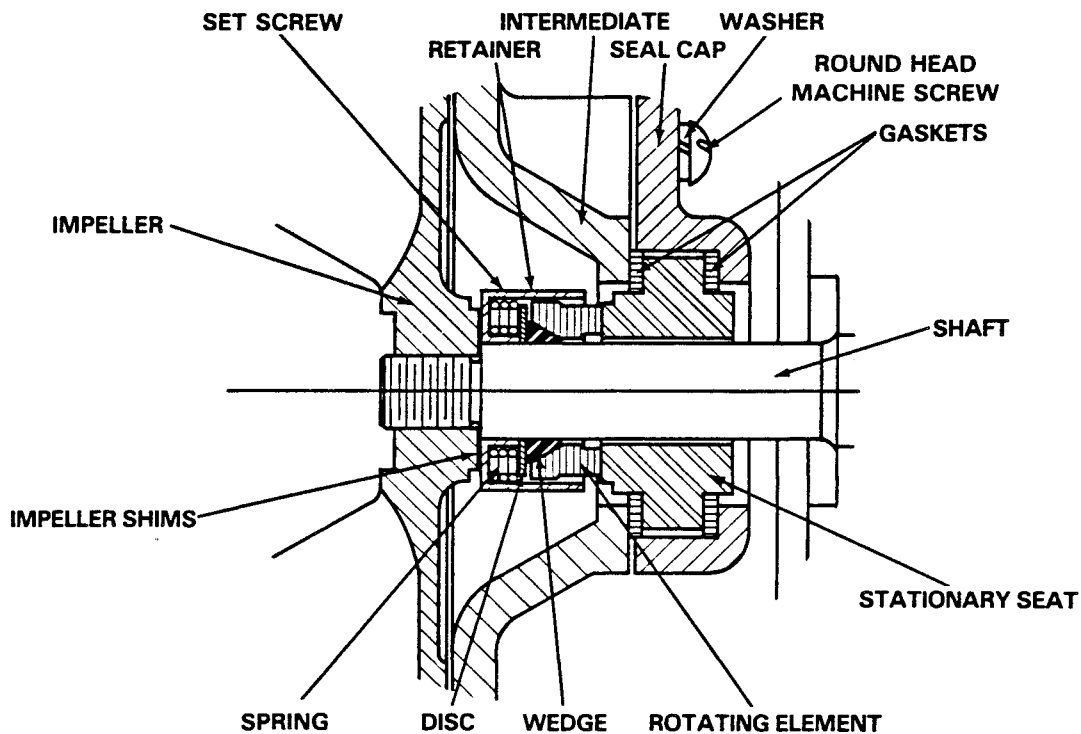

Figure 2. S01219 Seal Assembly

#### CAUTION

This seal is not designed for operation at temperatures above 160° F. Do not use at higher operating temperatures.

If a completely **new seal** assembly is being installed, remove it from the container, and inspect the precision finished faces to ensure that they are not damaged and are free of any foreign matter. Install the stationary seat and gaskets in the seal cap as previous described, and secure the seal cap to the

intermediate. Position the intermediate on the shaft and secure with hardware previously removed.

Lubricate the I.D. of the wedge with soft grease or oil, and slide the rotating portion of the new seal assembly onto the shaft. A new seal assembly is furnished with restraining clips which keep the wedge from being compressed prior to assembly.

Position the seal retainer at the proper mounting distance on the shaft as previously described. Tighten the four setscrews with an allen wrench and lock in-place with a punch to prevent loosening. **Remove and discard the seal spring restraining clips.**

#### WARNING

```

////////////////////////////////////
//                               //
// New seal assemblies are equipped with spring holding //
// clips for storage purposes. Remove and discard these //
// clips before proceeding with seal reassembly. When re- //
// moving the clips, use caution so that they do not pop //
// off abruptly and cause personal injury. Failure to re- //
// move these clips can result in seal failure and pump //
// damage. //
//                               //
////////////////////////////////////

```

Place a drop of light lubricating oil on the precision finished faces of the stationary seat and the rotating element. Slide the assembled seal parts completely on the shaft.

#### NOTE

It is recommended that tapered sleeve be installed over the threads of the impeller shaft to ease installation of the rotating seal components.

### Pump Reassembly

#### (Figure 1)

Inspect the impeller, and replace it if cracked or badly worn.

Install the same number of impeller adjusting shims (27) as previously removed. Install the seal washer (25) and screw the impeller onto the shaft.

A clearance of .008 to .015 inch between the impeller and the vane plate is necessary for maximum pump efficiency. To achieve this clearance, secure the vane plate to the intermediate rotate the impeller shaft by hand. If the impeller binds slightly against the vane plate, remove the impeller, and remove .010 inch of impeller shims. Reassemble the pump. The clearance between the impeller and the vane plate should now be correct.

If the shaft moves freely when rotated by hand, remove the impeller, and add another impeller shim. Reassemble the pump and rotate the shaft by hand. Repeat this procedure, adding one shim at a time, until the impeller binds slightly

---

---

against the vane plate. When this occurs, remove .010 inch of shims as indicated above.

After the proper clearance is achieved, apply 3M-847 sealant (or equivalent) on the vane plate and secure it to the intermediate.

#### NOTE

An alternate method of setting this clearance is to install the impeller with no adjusting shims. Use a depth micrometer to measure the height of the impeller vanes from the intermediate, and the depth of the impeller cavity in the vane plate. Subtract one measurement from the other to obtain the distance between the impeller and the vane plate. Subtract approximately .012 inch from this figure to obtain the thickness of adjusting shims required.

Install a new vane plate O-ring (26) and pump casing gasket (23) and reassemble the pump casing to the intermediate.

Reinstall the fill plug and fill the pump casing with clean liquid.

Refer to **OPERATION**, Section C, before putting the pump back into service.

## LUBRICATION

### Seal Assembly

The seal is a self-lubricating mechanical type that is lubricated by the medium being pumped.

### Bearings

The bearings are sealed and permanently lubricated and require no additional lubrication.



**For U.S. and International Warranty Information,  
Please Visit [www.grpumps.com/warranty](http://www.grpumps.com/warranty)  
or call:  
U.S.: 419-755-1280  
International: +1-419-755-1352**

**For Canadian Warranty Information,  
Please Visit [www.grcanada.com/warranty](http://www.grcanada.com/warranty)  
or call:  
519-631-2870**