

---

# **10** SERIES™

---

## **INSTALLATION, OPERATION, PARTS LIST, AND MAINTENANCE MANUAL**



**THE GORMAN-RUPP COMPANY • MANSFIELD, OHIO**

GORMAN-RUPP OF CANADA LIMITED • ST. THOMAS, ONTARIO, CANADA

Printed in U.S.A.

Copyright by the Gorman-Rupp Company



# TABLE OF CONTENTS

INTRODUCTION . . . . .	I-1
WARNINGS - SECTION A . . . . .	A-1
INSTALLATION - SECTION B . . . . .	B-1
Pump Dimensions . . . . .	B-1
PREINSTALLATION INSPECTION . . . . .	B-2
POSITIONING PUMP . . . . .	B-3
Lifting . . . . .	B-3
Mounting . . . . .	B-3
SUCTION AND DISCHARGE PIPING . . . . .	B-4
Materials . . . . .	B-4
Line Configuration . . . . .	B-4
Connections to Pump . . . . .	B-4
Gauges . . . . .	B-4
SUCTION LINES . . . . .	B-4
Fittings . . . . .	B-5
Strainers . . . . .	B-5
Sealing . . . . .	B-5
Suction Lines In Sumps . . . . .	B-5
Suction Line Positioning . . . . .	B-6
DISCHARGE LINES . . . . .	B-6
Siphoning . . . . .	B-6
Valves . . . . .	B-7
Bypass Lines . . . . .	B-7
ALIGNMENT . . . . .	B-7
OPERATION - SECTION C . . . . .	C-1
PRIMING . . . . .	C-1
STARTING . . . . .	C-2
OPERATION . . . . .	C-2
Lines With a Bypass . . . . .	C-2
Lines Without a Bypass . . . . .	C-2
Leakage . . . . .	C-3
Liquid Temperature And Overheating . . . . .	C-3
Strainer Check . . . . .	C-3
Pump Vacuum Check . . . . .	C-3
STOPPING . . . . .	C-4
Cold Weather Preservation . . . . .	C-4
BEARING TEMPERATURE CHECK . . . . .	C-4
PUMP TROUBLESHOOTING - SECTION D . . . . .	D-1
PUMP MAINTENANCE AND REPAIR - SECTION E . . . . .	E-1
PERFORMANCE CURVE . . . . .	E-1
PUMP MODEL - PARTS LIST . . . . .	E-3
PUMP END ASSY - PARTS LIST . . . . .	E-5
DRIVE ASSY - PARTS LIST . . . . .	E-7
PUMP AND SEAL DISASSEMBLY AND REASSEMBLY . . . . .	E-8
Back Cover Removal . . . . .	E-8
Suction Check Valve Removal . . . . .	E-9
Impeller Removal . . . . .	E-9
Seal Disassembly . . . . .	E-9
Pump Disassembly . . . . .	E-10
Separating Intermediate And Drive Assembly From Engine . . . . .	E-10
Impeller Shaft And Bearing Disassembly . . . . .	E-10
Impeller Shaft And Bearing Reassembly . . . . .	E-11
Securing Intermediate And Drive Assembly To Engine . . . . .	E-13
Pump Reassembly . . . . .	E-13
Seal Reassembly . . . . .	E-14
Impeller Reassembly And Adjustment . . . . .	E-16

Suction Check Valve Installation . . . . .	E-16
Back Cover Installation . . . . .	E-17
Final Pump Reassembly . . . . .	E-17
LUBRICATION . . . . .	E-18
Seal Assembly . . . . .	E-18
Bearings . . . . .	E-18
Engine . . . . .	E-18

INTRODUCTION

This Installation, Operation, and Maintenance Manual is designed to help you achieve the best performance and longest life from your Gorman-Rupp pump.

This pump is a 10 Series, semi-open impeller, self-priming centrifugal model with a suction check valve. The pump is designed for handling dirty water which contains specified entrained solids. The basic materials of construction for wetted parts is gray iron with ductile iron impeller and steel wearing parts.

If there are any questions regarding the pump or its application which are not covered in this manual or in other literature accompanying this unit, please contact your Gorman-Rupp distributor, or write:

The Gorman-Rupp Company	or	Gorman-Rupp of Canada Limited
P.O. Box 1217		70 Burwell Road
Mansfield, Ohio 44901		St. Thomas, Ontario N5P 3R7

For information or technical assistance on the engine, contact the engine manufacturer's local dealer or representative.

The following are used to alert maintenance personnel to procedures which require special attention, to those which could damage equipment, and to those which could be dangerous to personnel:

NOTE

Instructions to aid in installation, operation, and maintenance or which clarify a procedure.

CAUTION

Instructions which must be followed to avoid causing damage to the product or other equipment incidental to the installation. These instructions describe the requirements and the possible damage which could result from failure to follow the procedures.

WARNING

```

////////////////////////////////////
//
// These instructions must be followed to avoid causing in- //
// jury or death to personnel, and describe the procedure //
// required and the injury which could result from failure //
// to follow the procedure. //
// //
////////////////////////////////////

```



WARNINGS

WARNINGS - SECTION A

THESE WARNINGS APPLY TO 10 SERIES ENGINE DRIVEN PUMPS. REFER TO THE MANUAL ACCOMPANYING THE ENGINE BEFORE ATTEMPTING TO BEGIN OPERATION.

WARNING

```

////////////////////////////////////
//
// Before attempting to open or service the pump:
//
// 1. Familiarize yourself with this manual.
// 2. Switch off the engine ignition and remove the key
//    to ensure that the pump will remain inoperative.
// 3. Allow the pump to cool if overheated.
// 4. Vent the pump slowly and cautiously.
// 5. Close the suction and discharge valves.
// 6. Check the temperature before opening any covers,
//    plates, or plugs.
// 7. Drain the pump.
//
////////////////////////////////////

```

WARNING

```

////////////////////////////////////
//
// This pump is designed to pump dirty water containing
// specified entrained solids. Do not attempt to pump vol-
// atile, flammable, or corrosive liquids which may damage
// the pump or endanger personnel as a result of pump fail-
// ure.
//
////////////////////////////////////

```

WARNING

```

////////////////////////////////////
//
// Use lifting and moving equipment in good repair and with
// adequate capacity to prevent injuries to personnel or
// damage to equipment. The bail is intended for use in
// lifting the pump assembly only. Suction and discharge
// hoses and piping MUST be removed from the pump when
// lifting the pump by the bail.
//
////////////////////////////////////

```

WARNING

```

////////////////////////////////////
//
// After the pump has been positioned, make certain that
// the pump and all piping or hose connections are tight ,
// properly supported and secure before operation.
//
////////////////////////////////////

```

WARNINGS

WARNING

```

////////////////////////////////////
//
// Do not operate the pump against a closed discharge valve //
// for long periods of time. This could bring the liquid //
// to a boil, build pressure, and cause the pump to rupture //
// or explode. //
// //
////////////////////////////////////

```

WARNING

```

////////////////////////////////////
//
// Do not remove plates, covers, gauges, pipe plugs, or //
// fittings from an overheated pump. Vapor pressure within //
// the pump can cause parts being disengaged to be ejected //
// with great force. Allow the pump to cool before servic- //
// ing. //
// //
////////////////////////////////////

```

WARNING

```

////////////////////////////////////
//
// Do not operate an internal combustion engine in an ex- //
// plosive atmosphere. When operating internal combustion //
// engines in an enclosed area, make certain that exhaust //
// fumes are piped to the outside. These fumes contain //
// carbon monoxide, a deadly gas that is colorless, //
// tasteless, and odorless. //
// //
////////////////////////////////////

```

WARNING

```

////////////////////////////////////
//
// Fuel used by internal combustion engines presents an ex- //
// treme explosion and fire hazard. Make certain that all //
// fuel lines are securely connected and free of leaks. //
// Never refuel a hot or running engine. Avoid overfilling //
// the fuel tank. Always use the correct type of fuel. //
// //
////////////////////////////////////

```

WARNING

```

////////////////////////////////////
//
// Never tamper with the governor to gain more power. The //
// governor establishes safe operating limits that should //
// not be exceeded. The maximum continuous operating speed //
// is 2150 RPM. //
// //
////////////////////////////////////

```

## INSTALLATION

## INSTALLATION - SECTION B

Since pump installations are seldom identical, this section offers only general recommendations and practices required to inspect, position, and arrange the pump and piping.

Most of the information pertains to a standard **static lift application** where the pump is positioned above the free level of liquid to be pumped.

If installed in a **flooded suction application** where the liquid is supplied to the pump under pressure, some of the information such as mounting, line configuration, and priming must be tailored to the specific application. Since the pressure supplied to the pump is critical to performance and safety, **be sure** to limit the incoming pressure to 50% of the maximum pressure developed by the pump.

For further assistance, contact your Gorman-Rupp distributor or the Gorman-Rupp Company.

#### Pump Dimensions

See Figure 1 for the approximate physical dimensions of this pump and engine.

OUTLINE DRAWING

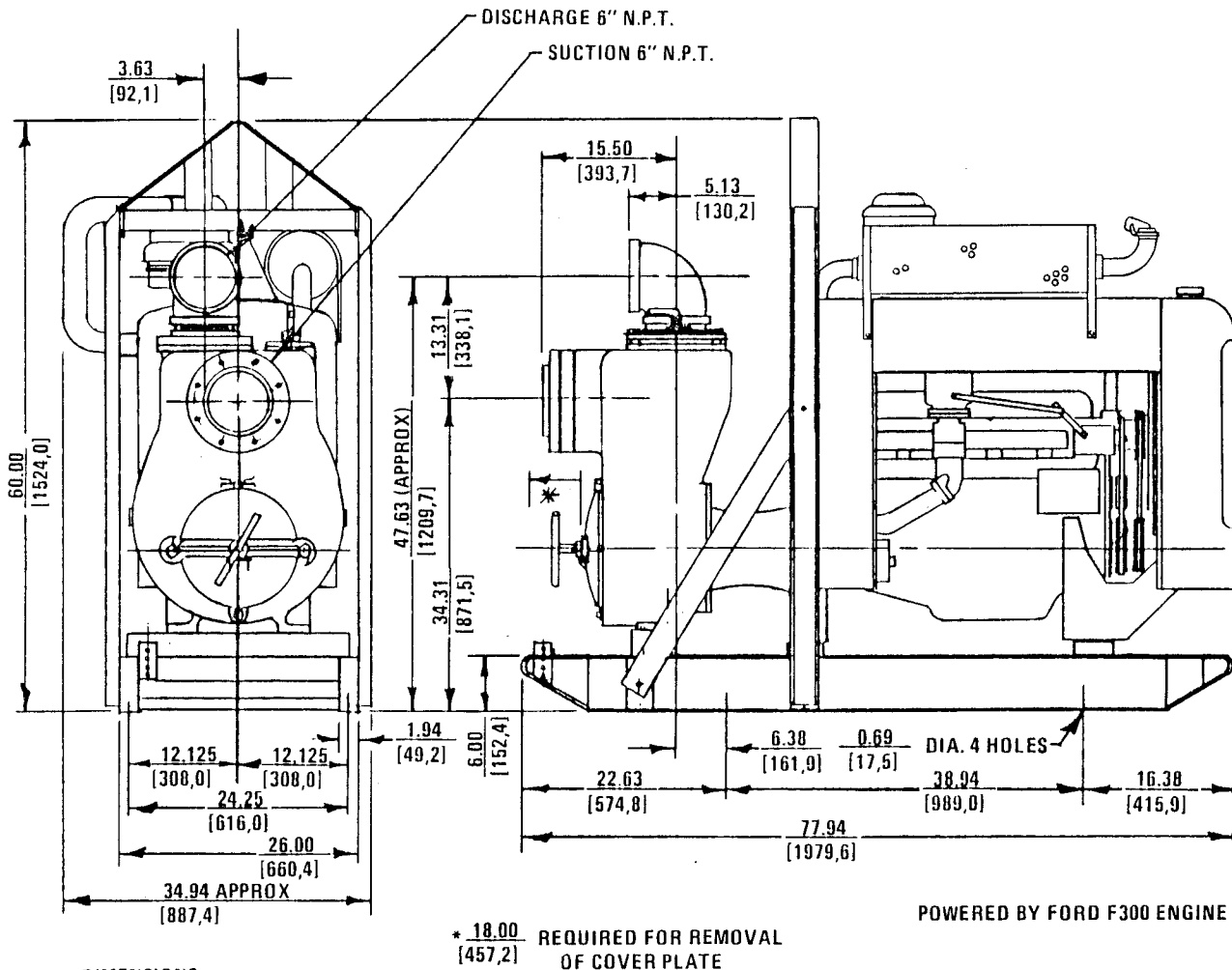

DIMENSIONS  
INCHES  
[MILLIMETERS]

Figure 1. Pump Model 16C20-F300

PREINSTALLATION INSPECTION

The pump assembly was inspected and tested before shipment from the factory. Before installation, inspect the pump for damage which may have occurred during shipment. Check as follows:

- a. Inspect the pump and engine for cracks, dents, damaged threads, and other obvious damage.
- b. Check for and tighten loose bolts, nuts, capscrews, and other attaching hardware. Since gaskets tend to shrink after drying, check for and tighten loose nuts and capscrews securing mating surfaces.
- c. Carefully read all tags, decals, and markings on the pump assembly, and follow the instructions indicated.

## INSTALLATION

- 
- 
- d. Check all lubricant levels and lubricate as necessary. Refer to LUBRICATION in the MAINTENANCE AND REPAIR section of this manual and perform duties as instructed.
  - e. If the pump and engine have been stored for more than 12 months, some of the components or lubricants may have exceeded their maximum shelf life. These **must be inspected or replaced** to ensure maximum pump service.

If the maximum shelf life has been exceeded, or if anything appears to be abnormal, contact your Gorman-Rupp distributor or the factory to determine the repair or updating policy. **Do not** put the pump into service until appropriate action has been taken.

## POSITIONING PUMP

## Lifting

Use lifting equipment with a capacity of a least **9,250 pounds**. This pump weighs approximately **1,850 pounds**, not including the weight of accessories and wheel kit. Customer installed equipment such as suction and discharge hoses **must** be removed before attempting to lift.

## CAUTION

The pump assembly can be seriously damaged if the cables or chains used to lift and move the unit are improperly wrapped around the pump.

## Mounting

Locate the pump in an accessible place as close as practical to the liquid being pumped. Level mounting is essential for proper operation. The pump may have to be supported or shimmed to provide for level operation or to eliminate vibration.

If the pump has been mounted on a moveable base, make certain the base is stationary by setting the brake and blocking the wheels before attempting to operate the pump.

---

---

## SUCTION AND DISCHARGE PIPING

### Materials

Either pipe or hose may be used for suction and discharge lines; however, the materials must be compatible with the liquid being pumped. If hose is used in suction lines, it must be the rigid-wall, reinforced type to prevent collapse under suction. Using piping couplings in suction lines is not recommended.

### Line Configuration

Keep suction and discharge lines as straight as possible to minimize friction losses. Make minimum use of elbows and fittings, which substantially increase friction loss. If elbows are necessary, use the long-radius type to minimize friction loss.

### Connections to Pump

Before tightening a connecting flange, align it exactly with the pump port. Never pull a pipe line into place by tightening the flange bolts and/or couplings.

Lines near the pump must be independently supported to avoid strain on the pump which could cause excessive vibration, decreased bearing life, and increased shaft and seal wear. If hose-type lines are used, they should have adequate support to secure them when filled with liquid and under pressure.

### Gauges

Most pumps are drilled and tapped for installing discharge pressure and vacuum suction gauges. If these gauges are desired for pumps that are not tapped, drill and tap the suction and discharge lines not less than 18 inches from the suction and discharge ports and install the lines. Installation closer to the pump may result in erratic readings.

## SUCTION LINES

To avoid air pockets which could affect pump priming, the suction line must be as short and direct as possible. When operation involves a suction lift, the line must always slope upward to the pump from the source of the liquid being pumped; if the line slopes down to the pump at any point along the suction run, air pockets will be created.

---

---

## INSTALLATION

---

---

### Fittings

Suction lines should be the same size as the pump inlet. If reducers are used in suction lines, they should be the eccentric type, and should be installed with the flat part of the reducers uppermost to avoid creating air pockets. Valves are not normally used in suction lines, but if a valve is used, install it with the stem horizontal to avoid air pockets.

### Strainers

If a strainer is furnished with the pump, be certain to use it; any spherical solids which pass through a strainer furnished with the pump will also pass through the pump itself.

If a strainer is not furnished with the pump, but is installed by the pump user, make certain that the total area of the openings in the strainer is at least three or four times the cross section of the suction line, and that the openings will not permit passage of solids larger than the solids handling capability of the pump.

This pump is designed to handle up to 3 inch diameter spherical solids.

### Sealing

Since even a slight leak will affect priming, head, and capacity, especially when operating with a high suction lift, all connections in the suction line should be sealed with pipe dope to ensure an airtight seal. Follow the sealant manufacturer's recommendations when selecting and applying the pipe dope. The pipe dope should be compatible with the liquid being pumped.

### Suction Lines In Sumps

If a single suction line is installed in a sump, it should be positioned away from the wall of the sump at a distance equal to one and one-half times the diameter of the suction line.

If there is a liquid flow from an open pipe into the sump, the flow should be kept away from the suction inlet because the inflow will carry air down into the sump, and air entering the suction line will reduce pump efficiency.

If it is necessary to position inflow close to the suction inlet, install a baffle between the inflow and the suction inlet at a distance one and one-half times the diameter of the suction pipe. The baffle will allow entrained air to escape from the liquid before it is drawn into the suction inlet.

If two suction lines are installed in a single sump, the flow paths may interact, reducing the efficiency of one or both pumps. To avoid this, position the suction inlets so that they are separated by a distance equal to at least three times the diameter of the suction pipe.

Suction Line Positioning

The depth of submergence of the suction line is critical to efficient pump operation. Figure 2 shows recommended minimum submergence vs. velocity.

NOTE

The pipe submergence required may be reduced by installing a standard pipe increaser fitting at the end of the suction line. The larger opening size will reduce the inlet velocity. Calculate the required submergence using the following formula based on the increased opening size (area or diameter).

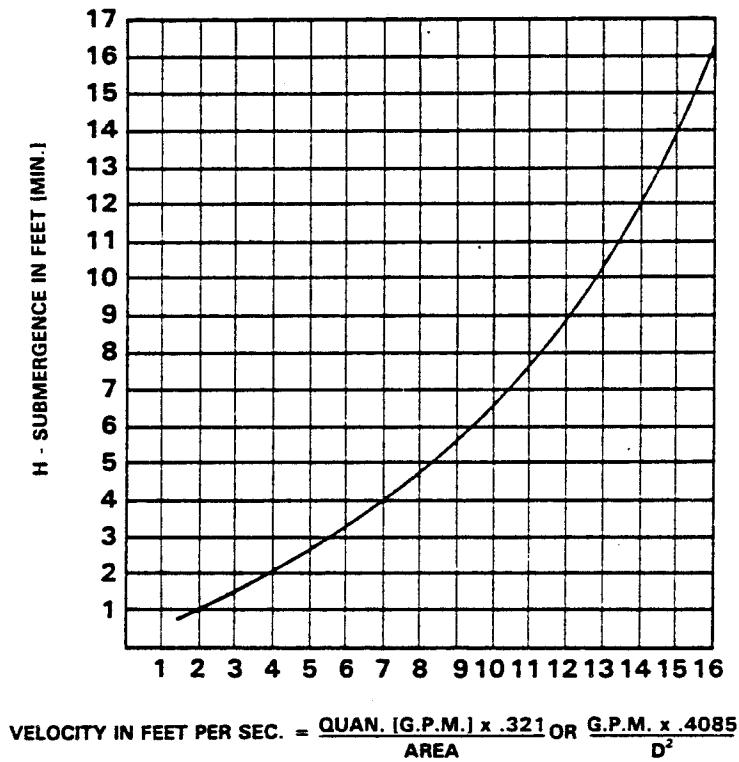

Figure 2. Recommended Minimum Suction Line Submergence Vs. Velocity

DISCHARGE LINES

Siphoning

Do not terminate the discharge line at a level lower than that of the liquid being pumped unless a siphon breaker is used in the line. Otherwise, a siphoning action causing damage to the pump could result.

---

---

---

## INSTALLATION

---

---

---

### Valves

A check valve in the discharge line is normally recommended, but it is not necessary in low discharge head applications.

If a throttling valve is desired in the discharge line, use a valve as large as the largest pipe to minimize friction losses. Never install a throttling valve in a suction line.

With high discharge heads, it is recommended that a throttling valve and a system check valve be installed in the discharge line to protect the pump from excessive shock pressure and reverse rotation when it is stopped.

### Bypass Lines

If it is necessary to permit the escape of air to atmosphere during initial priming or in the repriming cycle, install a bypass line between the pump and the discharge check valve. The bypass line should be sized so that it does not affect pump discharge capacity.

Either a Gorman-Rupp automatic air release valve - which will automatically open to allow the pump to prime, and automatically close when priming is accomplished - or a hand-operated shutoff valve should be installed in the bypass line.

### NOTE

The bypass line may clog frequently, particularly if the valve remains closed. If this condition occurs, either use a larger bypass line or leave the shutoff valve open during the pumping operation.

Do not terminate the discharge line at a level lower than that of the liquid being pumped unless a siphon breaker is used in the line. Otherwise, a siphoning action could result, causing damage to the pump.

### ALIGNMENT

The alignment of the pump and the engine is critical for trouble free mechanical operation. See Section E, **Securing Pump And Drive Assembly To Engine** for detailed information.



OPERATION

OPERATION - SECTION C

WARNING

```

////////////////////////////////////
//
// This pump is designed to pump dirty water containing //
// specified entrained solids. Do not attempt to pump vol- //
// atile, flammable, or corrosive liquids which may damage //
// the pump or endanger personnel as a result of pump fail- //
// ure. //
// //
////////////////////////////////////

```

WARNING

```

////////////////////////////////////
//
// Never tamper with the governor to gain more power. The //
// governor establishes safe operating limits that should //
// not be exceeded. The maximum continuous operating speed //
// is 2150 RPM. //
// //
////////////////////////////////////

```

PRIMING

Install the pump and piping as described in INSTALLATION. Make sure that the piping connections are tight, and that the pump is securely mounted. Check that the pump is properly lubricated (see LUBRICATION in MAINTENANCE AND REPAIR).

This pump is self-priming, but the pump should never be operated unless there is liquid in the casing.

CAUTION

<p>Never operate a self-priming pump unless there is liquid in the casing. The pump will not prime when dry. Extended operation of a dry pump will destroy the seal assembly.</p>
---

Add liquid to the pump casing when:

1. The pump is being put into service for the first time.
2. The pump has not been used for a considerable length of time.
3. The liquid in the pump casing has evaporated.

Once the pump casing has been filled, the pump will prime and reprime as necessary.

**WARNING**

```

////////////////////////////////////
//
// After filling the pump casing, reinstall and tighten the //
// fill plug. Do not attempt to operate the pump unless //
// all connecting piping is securely installed. Otherwise, //
// liquid in the pump forced out under pressure could cause //
// injury to personnel. //
// //
////////////////////////////////////

```

To fill the pump, remove the pump casing fill cover or fill plug at the top of the casing and add clean liquid until the pump is filled. Replace the fill cover or fill plug before operating the pump.

**STARTING**

Consult the operations manual furnished with the engine.

**OPERATION****Lines With a Bypass**

Either a Gorman-Rupp automatic air release valve or a hand operated shutoff valve may be installed in a bypass line.

If a Gorman-Rupp automatic air release valve has been installed, close the throttling valve in the discharge line. The Gorman-Rupp valve will automatically open to allow the pump to prime, and automatically close when priming has been accomplished. After the pump has been primed, and liquid is flowing steadily from the bypass line, open the discharge throttling valve.

If a hand operated shutoff valve has been installed, close the throttling valve in the discharge line, and open the bypass shutoff valve so that the pump will not have to prime against the weight of the liquid in the discharge line. When the pump has been primed, and liquid is flowing steadily from the bypass line, close the bypass shutoff valve and open the discharge throttling valve.

**Lines Without a Bypass**

Open all valves in the discharge line and start the power source. Priming is indicated by a positive reading on the discharge pressure gauge or by a quieter operation. The pump may not prime immediately because the suction line must first fill with liquid. If the pump fails to prime within five minutes, stop it and check the suction line for leaks.

After the pump has been primed, partially close the discharge line throttling valve in order to fill the line slowly and guard against excessive shock pres-

OPERATION

sure which could damage pipe ends, gaskets, sprinkler heads, and any other fixtures connected to the line. When the discharge line is completely filled, adjust the throttling valve to the required flow rate.

Leakage

No leakage should be visible at pump mating surfaces, or at pump connections or fittings. Keep all line connections and fittings tight to maintain maximum pump efficiency.

Liquid Temperature And Overheating

The maximum liquid temperature for this pump is 160°F. Do not apply it at a higher operating temperature.

Overheating can occur if operated with the valves in the suction or discharge lines closed. Operating against closed valves could bring the liquid to a boil, build pressure, and cause the pump to rupture or explode. If overheating occurs, stop the pump and allow it to cool before servicing it. Refill the pump casing with cool liquid.

WARNING

Do not remove plates, covers, gauges, pipe plugs, or fittings from an overheated pump. Vapor pressure within the pump can cause parts being disengaged to be ejected with great force. Allow the pump to cool before servicing.

Strainer Check

If a suction strainer has been shipped with the pump or installed by the user, check the strainer regularly, and clean it as necessary. The strainer should also be checked if pump flow rate begins to drop. If a vacuum suction gauge has been installed, monitor and record the readings regularly to detect strainer blockage.

Pump Vacuum Check

With the pump inoperative, install a vacuum gauge in the system, using pipe dope on the threads. Block the suction line and start the pump. At operating speed the pump should pull a vacuum of 20 inches or more of mercury. If it does not, check for air leaks in the seal, gasket, or discharge valve.

---

---

Open the suction line, and read the vacuum gauge with the pump primed and at operating speed. Shut off the pump. The vacuum gauge reading will immediately drop proportionate to static suction lift, and should then stabilize. If the vacuum reading falls off rapidly after stabilization, an air leak exists. Before checking for the source of the leak, check the point of installation of the vacuum gauge.

## STOPPING

Never halt the flow of liquid suddenly. If the liquid being pumped is stopped abruptly, damaging shock waves can be transmitted to the pump and piping system. Close all connecting valves slowly. If the pump is driven by an engine, reduce the throttle speed slowly and allow the engine to idle briefly before stopping.

## CAUTION

If application involves a high discharge head, gradually close the discharge throttling valve before stopping the pump.

After stopping the pump, remove the engine ignition key or take other action to ensure that the pump will remain inoperative.

## Cold Weather Preservation

In below freezing conditions, drain the pump to prevent damage from freezing. Also, clean out any solids by flushing with a hose. Operate the pump for approximately one minute; this will remove any remaining liquid that could freeze the pump rotating parts.

If the pump will be idle for more than a few hours, or if it has been pumping liquids containing a large amount of solids, drain the pump, and flush it thoroughly with clean water. To prevent large solids from clogging the drain port and preventing the pump from completely draining, insert a rod or stiff wire in the drain port, and agitate the liquid during the draining process. Clean out any remaining solids by flushing with a hose.

## BEARING TEMPERATURE CHECK

Bearings normally run at higher than ambient temperatures because of heat generated by friction. Temperatures up to 160°F are considered normal for bearings, and they can operate safely to at least 180°F.

Checking bearing temperatures by hand is inaccurate. Bearing temperatures can be measured accurately by placing a contact-type thermometer against the housing. Record this temperature for future reference.

---

---

---

## OPERATION

---

---

---

A sudden increase in bearing temperatures is a warning that the bearings are at the point of failing to operate properly. Make certain that the bearing lubricant is of the proper viscosity and at the correct level (see LUBRICATION in MAINTENANCE AND REPAIR). Bearing overheating can also be caused by shaft misalignment and/or excessive vibration.

When pumps are first started, the bearings may seem to run at temperatures above normal. Continued operation should bring the temperatures down to normal levels.



PUMP TROUBLESHOOTING - SECTION D

WARNING

```

////////////////////////////////////
//
// Before attempting to open or service the pump:
//
// 1. Familiarize yourself with this manual.
// 2. Switch off the engine ignition and remove the key
//    to ensure that the pump will remain inoperative.
// 3. Allow the pump to cool if overheated.
// 4. Vent the pump slowly and cautiously.
// 5. Close the suction and discharge valves.
// 6. Check the temperature before opening any covers,
//    plates, or plugs.
// 7. Drain the pump.
//
////////////////////////////////////
    
```

TROUBLE	POSSIBLE CAUSE	PROBABLE REMEDY
PUMP FAILS TO PRIME	Air leak in suction line. Lining of suction hose collapsed. Leaking or worn seal or pump gasket. Suction lift or discharge head too high. Strainer clogged. Suction check valve or foot valve clogged or binding.	Correct leak. Replace suction hose. Check pump vacuum. Replace leaking or worn seal or gasket. Check piping installation and install bypass line if needed. See INSTALLATION. Check strainer and clean if necessary. Clean valve.
PUMP STOPS OR FAILS TO DELIVER RATED FLOW OR PRESSURE	Air leak in suction line. Suction intake not submerged at proper level or sump too small.	Correct leak. Check installation and correct as needed. Check submergence chart (Section B).

TROUBLE	POSSIBLE CAUSE	PROBABLE REMEDY
PUMP STOPS OR FAILS TO DELIVER RATED FLOW OR PRES-SURE(cont.)	<p>Lining of suction hose collapsed.</p> <p>Impeller or other wearing parts worn or damaged.</p> <p>Impeller clogged.</p> <p>Suction lift or discharge head too high.</p> <p>Strainer clogged.</p> <p>Pump speed too slow.</p> <p>Leaking or worn seal or pump gasket.</p>	<p>Replace suction hose.</p> <p>Replace worn or damaged parts. Check that impeller is properly centered and rotates freely.</p> <p>Free impeller of debris.</p> <p>Check piping installation and install bypass line if needed. See INSTALLATION.</p> <p>Check strainer and clean if necessary.</p> <p>Check engine output; consult engine operation manual.</p> <p>Check pump vacuum. Replace leaking or worn seal or gasket.</p>
PUMP REQUIRES TOO MUCH POWER	<p>Pump speed too high.</p> <p>Discharge head too low.</p> <p>Liquid solution too thick.</p> <p>Bearing(s) frozen.</p>	<p>Check engine output.</p> <p>Adjust discharge valve.</p> <p>Dilute if possible.</p> <p>Disassemble pump and check bearing(s).</p>
PUMP CLOGS FREQUENTLY	<p>Discharge flow too slow.</p> <p>Suction check valve or foot valve clogged or binding.</p> <p>Liquid solution too thick.</p>	<p>Open discharge valve fully to increase flow rate, and run engine at maximum governed speed.</p> <p>Clean valve.</p> <p>Dilute if possible.</p>

TROUBLE	POSSIBLE CAUSE	PROBABLE REMEDY
EXCESSIVE NOISE	<p>Cavitation in pump.</p> <p>Pumping entrained air.</p> <p>Pump or drive not securely mounted.</p> <p>Impeller clogged or damaged.</p>	<p>Reduce suction lift and/or friction losses in suction line. Record vacuum and pressure gauge readings and consult local representative or factory.</p> <p>Locate and eliminate source of air bubble.</p> <p>Secure mounting hardware.</p> <p>Clean out debris; replace damaged parts.</p>
BEARINGS RUN TOO HOT	<p>Bearing temperature is high, but within limits.</p> <p>Low or incorrect lubricant.</p> <p>Suction and discharge lines not properly supported.</p> <p>Drive misaligned.</p>	<p>Check bearing temperature regularly to monitor any increase.</p> <p>Check for proper type and level of lubricant.</p> <p>Check piping installation for proper support.</p> <p>Align drive properly.</p>



PUMP MAINTENANCE AND REPAIR - SECTION E

MAINTENANCE AND REPAIR OF THE WEARING PARTS OF THE PUMP WILL MAINTAIN PEAK OPERATING PERFORMANCE.

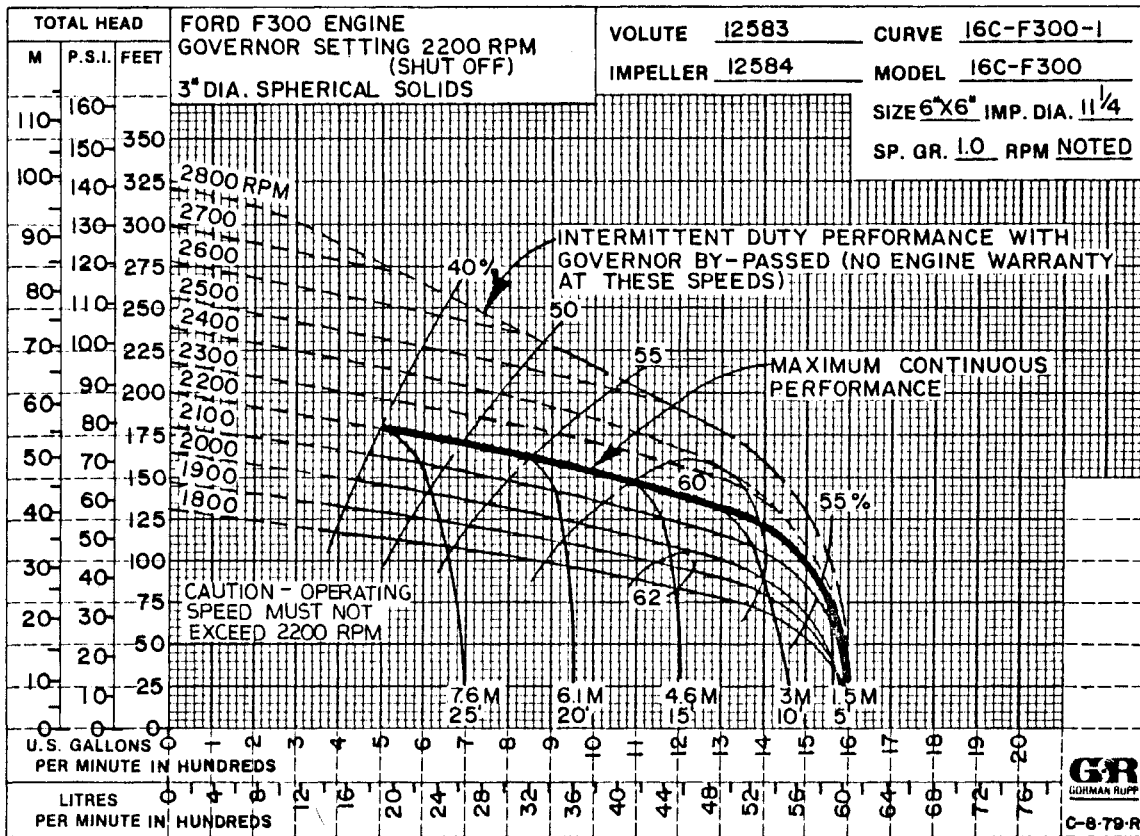

\*STANDARD PERFORMANCE FOR PUMP MODEL 16C20-F300

\*Based on 70°F clear water at sea level with minimum suction lift. Since pump installations are seldom identical, your performance may be different due to such factors as viscosity, specific gravity, elevation, temperature, and impeller trim.

If your pump serial number is followed by an "N", your pump is NOT a standard production model. Contact the Gorman-Rupp Company to verify performance or part numbers.

CAUTION

Pump speed and operating condition points must be within the continuous performance range shown on the curve.

SECTIONAL DRAWING

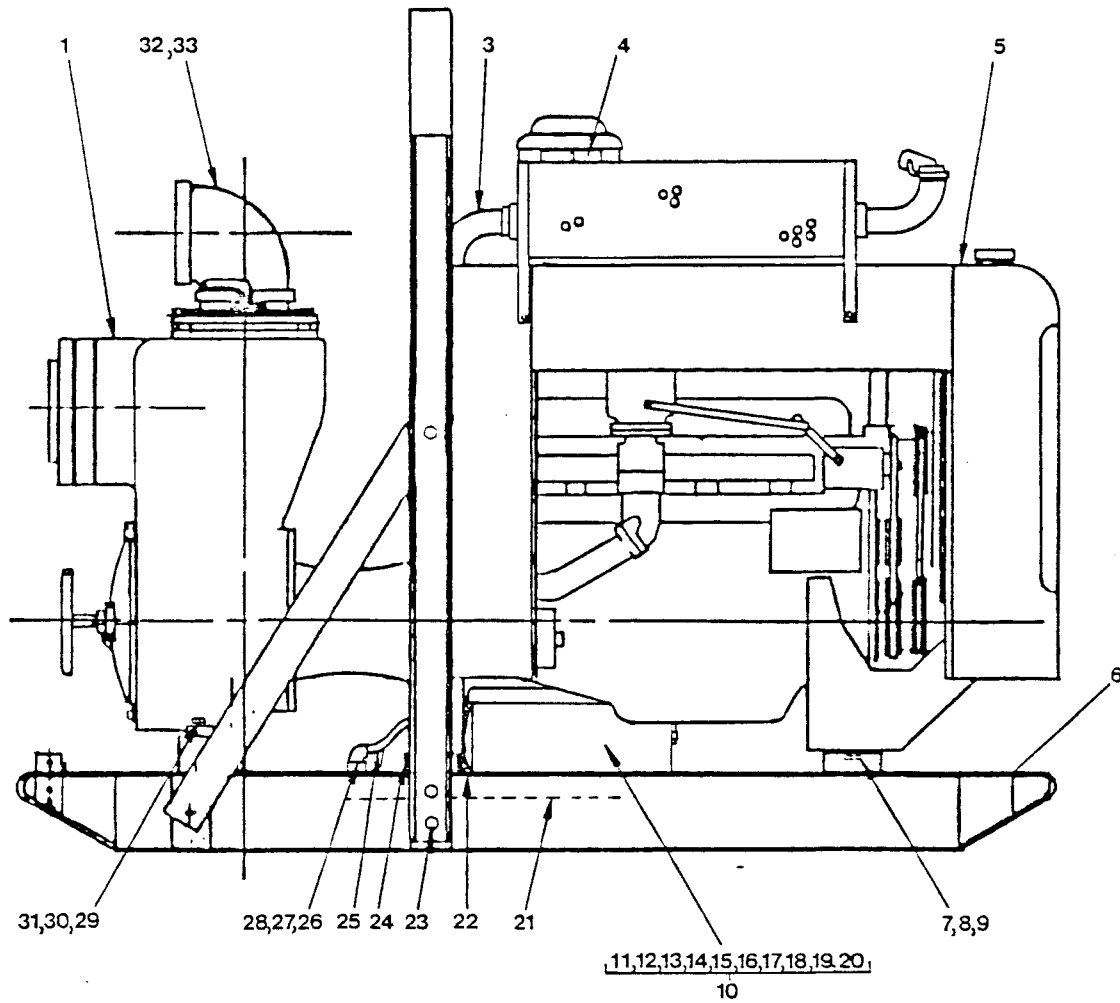

Figure 1. Model 16C20-F300 Pump Assembly

**PARTS LIST**  
**Pump Model 16C20-F300**  
 (From S/N 806819 up)

ITEM NO.	PART NAME	PART NUMBER	MATL CODE	QTY	ITEM NO.	PART NAME	PART NUMBER	MATL CODE	QTY
1	PUMP END	16C20 (SEE FIG. 2)		1	20	* -12V BATTERY	S01338	-----	1
2	HOISTING BAIL	13351-Q	24000	1	21	FUEL TANK AND GUARD ASSY	46711-033	-----	1
3	AIR CLEANER HOSE	31417-007	-----	1		-FUEL TANK	46711-034	24150	1
	AIR CLNR PIPE ASSY	31921-019	-----	1		HEX HD CAPSCREW	B00604	15991	10
	-AIR CLEANER PIPE	31921-002	-----	1		LOCKWASHER	J00006	15991	10
	-SLEEVE	31144-013	-----	2		HEX NUT	D00006	15991	10
	HOSE CLAMP	26518-671	-----	1	22	GRD CABLE ASSY	5795-AB	24040	1
	HOSE CLAMP	26518-675	-----	1	23	HEX HD CAPSCREW	B01006	15991	8
4	AIR CLEANER BRKT	41823-005	-----	1		LOCKWASHER	J00010	15991	8
	HEX HD CAPSCREW	B00503	15991	3		HEX NUT	D00010	15991	8
	LOCKWASHER	J00005	15991	3	24	HEX HD CAPSCREW	B00806	15991	2
	FLAT WASHER	K00005	15991	3		LOCKWASHER	J00010	15991	2
	HEX NUT	D00005	15991	3		HEX NUT	D00010	15991	2
5	FORD C5PG ENGINE	204-K3	-----	1	25	FUEL LINE ASSY	12618	-----	1
6	COMBINATION BASE	12464	24000	1	26	FUEL OUTLET ASSY	10765	24030	1
7	HEX HD CAPSCREW	B00804	15991	2	27	REDUCING ELBOW	Q00604	11990	1
8	LOCKWASHER	J00008	15991	2	28	CONNECTOR	S01344	-----	1
9	HEX NUT	D00008	15991	2	29	HEX HD CAPSCREW	B01009	15991	2
10	BATTERY BOX ASSY	GRP40-02	-----	1	30	LOCKWASHER	J00010	15991	2
11	* -GROUND CABLE ASSY	5795-AC	24040	1	31	HEX NUT	D00010	15991	2
12	-BATTERY BOX	08356-B	24000	1	32	PIPE ELBOW	R00096	11990	1
13	-BATTERY FRAME	08355-B	24000	1	33	PIPE NIPPLE	T00096	15070	1
14	-BATTERY TAG	06588-S	00000	1		NOT SHOWN:			
15	-HEX HD CAPSCREW	B00604	15991	2		STRAINER	7823-A	24000	1
16	-HEX HD CAPSCREW	B00612	15991	2		WARNING DECAL	2613-FE	-----	1
17	-HEX NUT	D00006	15991	4		NAME PLATE	2613-D	13990	1
18	-LOCKWASHER	J00006	15991	4					
19	-FLAT WASHER	K00006	15991	2					

\*INDICATES PARTS RECOMMENDED FOR STOCK

Above Serial Numbers Do Not Apply To Pumps Made In Canada.

CANADIAN SERIAL NO ..... AND UP

SECTIONAL DRAWING

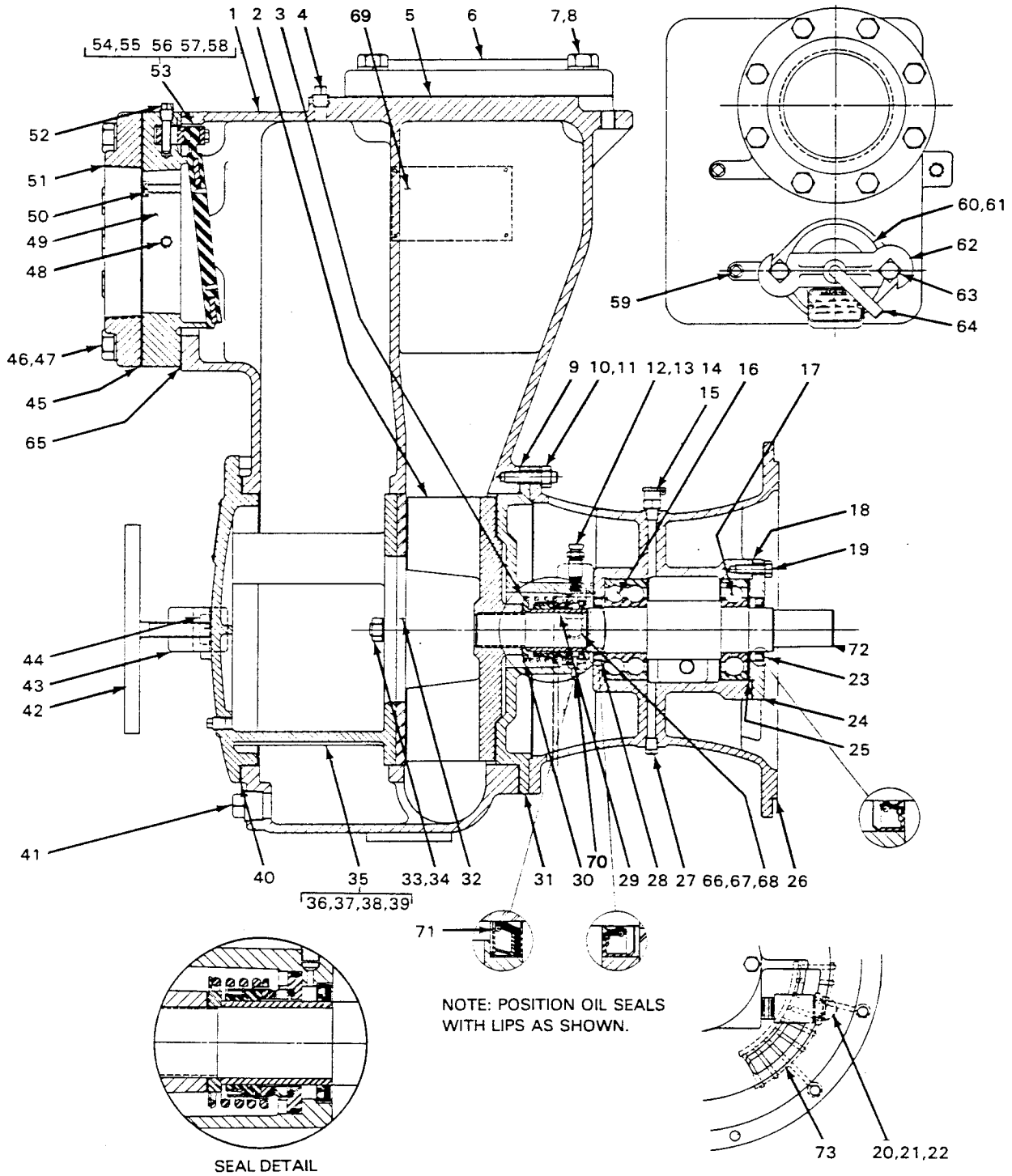

Figure 2. Pump End Assy 16C20-F300

**PARTS LIST**  
**Pump End Assy 16C20-F300**

ITEM NO.	PART NAME	PART NUMBER	MATL CODE	QTY	ITEM NO.	PART NAME	PART NUMBER	MATL CODE	QTY
1	PUMP CASING	12583	10010	1	39	-DRAIN PLUG	P00004	11990	1
2	*IMPELLER	12584	11000	1	40	*COVER GSKT	7668-G	20000	1
3	*SEAL ASSY	12461	-----	1	41	CASING DRAIN PLUG	P00016	11990	1
4	PIPE PLUG	P00004	11990	1	42	COVER CLAMP SCREW	2536	24000	1
5	*DISCH FLANGE GSKT	1679-G	18000	1	43	COVER CLAMP BAR	12586	11000	1
6	DISCHARGE FLANGE	1758	10010	1	44	MACHINE BOLT	A01010	15991	2
7	HEX HD CAPSCREW	B01208	15991	8	45	*SUCTION FLANGE GSKT	1679-G	18000	1
8	LOCKWASHER	J00012	15991	8	46	HEX HD CAPSCREW	B01214	15991	8
9	*CASING GSKT SET	34-G	18000	1	47	LOCKWASHER	J00012	15991	8
10	STUD	C00809	15991	8	48	PIPE PLUG	P00004	11990	1
11	HEX NUT	D00008	15991	8	49	*CHECK VALVE SEAT	11402-C	10010	1
12	*SEAL AIR VENT	S02162	-----	1	50	RD HD MACH SCREW	X00506	14990	2
13	PIPE COUPLING	AE00002	11990	1	51	SUCTION FLANGE	1758	10010	1
14	CLOSE NIPPLE	T00002	15070	1	52	CHECK VALVE PIN	11645	17010	1
15	*OIL HOLE COVER	26717-068	-----	1	53	*CHECK VALVE ASSY	46411-064	-----	1
16	*BALL BEARING	23421-461	-----	1	54	-ADAPTOR	NOT AVAILABLE		1
17	*BALL BEARING	S01077	-----	1	55	-CHECK VALVE	NOT AVAILABLE		1
18	*BEARING CAP GSKT	5413-G	18000	1	56	-SPACER SLEEVE	NOT AVAILABLE		2
19	HEX HD CAPSCREW	B00604	15991	4	57	-BACKUP PLATE	NOT AVAILABLE		1
20	*OIL LEVEL SIGHT GAUGE	S01471	-----	1	58	-HEX HD CAPSCREW	NOT AVAILABLE		2
21	CLOSE NIPPLE	T00012	15070	1	59	PIPE PLUG	P00004	11990	1
22	PIPE COUPLING	AE00012	11990	1	60	FILL COVER ASSY	42111-344	-----	1
23	*OIL SEAL	25258-622	-----	1	61	*FILL COVER GSKT	50-G	19210	1
24	*BEARING CAP	4185-A	10010	1	62	FILL COVER CLAMP BAR	38111-004	11000	1
25	*WAVY WASHER	23963-327	-----	1	63	MACHINE BOLT	A01014	15991	2
26	INTERMEDIATE	38263-718	10010	1	64	FILL COVER CLAMP SCREW	31912-009	15000	1
27	INTERM DRAIN PLUG	P00006	11990	1	65	*CHECK VALVE GSKT	11402-G	21020	1
28	*OIL SEAL	25258-622	-----	1	66	BOTTLE OILER	S1933	-----	1
29	*SHAFT SLEEVE	11907	17030	1	67	PIPE ELBOW	R00002	11990	1
30	*IMPELLER SHIM SET	5091	17090	1	68	PIPE NIPPLE	T00220	15070	1
31	*SEAL PLATE	38272-517	10010	1	69	NAME PLATE	2613-D	13990	1
32	*WEAR PLATE	2545	15990	1	70	SEAL DRAIN PLUG	P00002	11990	1
33	HEX NUT	D00008	15991	2	71	*OIL SEAL	S1935	-----	1
34	LOCKWASHER	J00008	15991	2	72	IMPELLER SHAFT	38514-807	16040	REF
35	*COVER ASSEMBLY	42111-935	-----	1	73	INTERMEDIATE GRD	42381-506	24150	REF
36	-COVER PLATE	NOT AVAILABLE		1	NOT SHOWN:				
37	-WARNING PLATE	2613-EV	13990	1	WARNING DECAL	38816-096	-----	1	
38	-DRIVE SCREW	BM#04-03	15990	4					

\*INDICATES PARTS RECOMMENDED FOR STOCK

SECTIONAL DRAWING

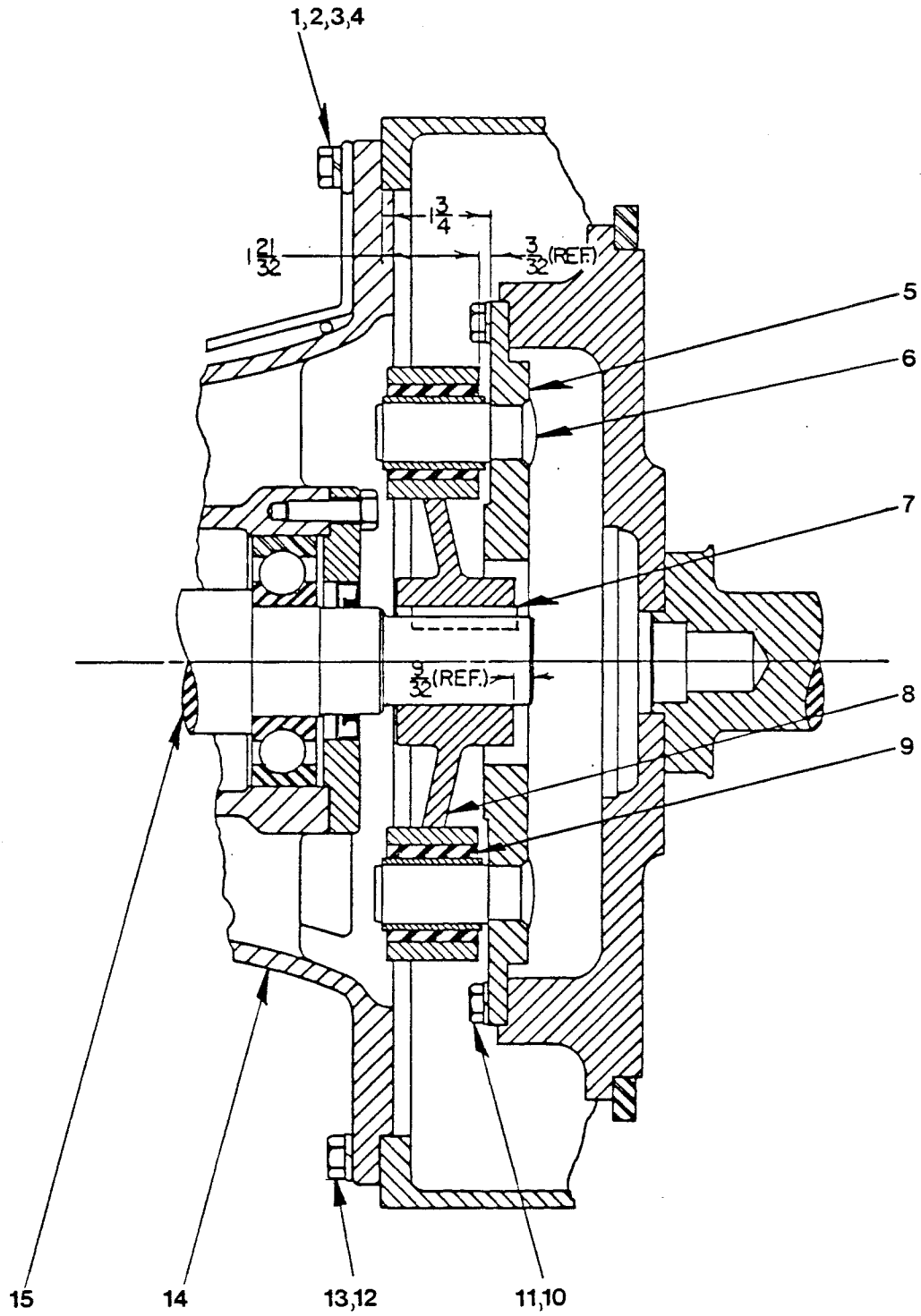

Figure 3. Drive Assembly For 16C20-F300

PARTS LIST  
Drive Assembly For 16C20-F300

ITEM NO.	PART NAME	PART NUMBER	MATL CODE	QTY
1	HEX HD CAPSCREW	B00606	15991	4
2	LOCKWASHER	J00006	15991	4
3	INTERMEDIATE GUARD	42381-506	24150	1
4	INTERMEDIATE GUARD	42381-507	24150	1
5	DRIVE PLATE ASSEMBLY	12320	15990	1
6	* -DRIVE PIN	13819	15030	2
7	* SHAFT KEY	N00607	15990	1
8	DRIVE ARM ASSEMBLY	13817-C	-----	1
9	* -DYNA FLEX JOINT	S02110	-----	2
10	HEX HD CAPSCREW	B00604	15991	8
11	LOCKWASHER	J00006	15991	8
12	HX HD CAPSCREW	B00605	15991	8
13	LOCKWASHER	J00006	15991	8
14	INTERMEDIATE	38263-718	10010	1
15	IMPELLER SHAFT	38514-807	16040	1

### PUMP AND SEAL DISASSEMBLY AND REASSEMBLY

This pump requires little service due to its rugged, minimum-maintenance design. However, if it becomes necessary to inspect or replace the wearing parts, follow these instructions which are keyed to the sectional views (see Figures 1, 2 and 3) and the accompanying parts lists.

Most service functions may be performed by draining the pump and removing the back cover assembly. If major repair is required, the piping and/or engine must be disconnected.

Before attempting to service the pump, take precautions to ensure that the engine will remain inoperative. Close all connecting valves.

#### WARNING

```

////////////////////////////////////
//
// Before attempting to open or service the pump:
//
// 1. Familiarize yourself with this manual.
// 2. Switch off the engine ignition and remove the key
//    to ensure that the pump will remain inoperative.
// 3. Allow the pump to cool if overheated.
// 4. Vent the pump slowly and cautiously.
// 5. Close the suction and discharge valves.
// 6. Check the temperature before opening any covers,
//    plates, or plugs.
// 7. Drain the pump.
//
////////////////////////////////////

```

#### WARNING

```

////////////////////////////////////
//
// Use lifting and moving equipment in good repair and with
// adequate capacity to prevent injuries to personnel or
// damage to equipment. The bail is intended for use in
// lifting the pump assembly only. Suction and discharge
// hoses and piping MUST be removed from the pump when
// lifting the pump by the bail.
//
////////////////////////////////////

```

### Back Cover Removal

#### (Figure 2)

The impeller, wear plate, check valve, and seal assembly can be serviced after the back cover assembly (35) has been removed.

Before removing the assembly, remove the casing drain plug (41) and drain the pump. Clean and reinstall the drain plug.

Loosen the cover clamp screw (42) and clamp bar (43) securing the back cover. Pull the back cover and assembled wear plate (32) from the pump casing (1).

---

---

## Suction Check Valve Removal

### (Figure 2)

After the back cover assembly has been removed, reach through the opening and hold the check valve assembly (53) in place while removing the check valve pin (52). Slide the assembly out of the check valve seat and remove it.

### NOTE

If the check valve assembly or any components require replacement, the complete assembly must be replaced. Individual parts are not sold separately.

The check valve assembly may also be serviced by removing the suction flange (51). Remove the hardware (46 and 47) securing the suction flange to the check valve seat (49). Remove the machine screws (50) and pull the seat and assembled check valve from the suction port. Remove the check valve pin (52), and remove the check valve.

Inspect the flange gaskets (45 and 65) for wear or damage, and replace as required.

## Impeller Removal

### (Figure 2)

Before removing the impeller, drain the seal lubricant by removing the seal drain plug (70). Clean and reinstall the plug.

To loosen the impeller (2), tap the vanes in a counterclockwise direction (when facing impeller) with a block of wood or a soft-faced mallet. Unscrew the impeller and replace it if cracked or badly worn. Use caution when removing the impeller; tension on the seal spring will be released as the impeller is unscrewed.

Slide the impeller adjusting shims (30) from the impeller shaft. For ease of reassembly, tag and tie the shims, or measure and record their thickness.

## Seal Disassembly

### (Figure 2)

Carefully remove the spring holder and spring. Slide the shaft sleeve and retainer assembly out of the seal plate bore and then slide the retainer assembly off the sleeve. Remove the rotating and stationary elements and assembled stationary seat with O-rings. Use a stiff wire with a hooked end if necessary.

If no further disassembly is required, see **Seal Reassembly**.

---

---

## Pump Disassembly

### (Figure 2)

To service the seal plate, intermediate, bearings, or drive assembly, the pump end must be removed from the base. See Figure 1, and remove the hardware (29, 30, and 31) securing the pump casing to the base.

Remove the nuts (11) securing the pump casing (1) to the intermediate, and separate the assemblies by pulling straight away. Remove the casing gaskets (9). If shims have been used under the mounting feet to level the pump casing, tag and tie these shims. Remove the air vent and piping (12, 13, and 14) and bottle oiler and piping (66, 67 and 68) from the seal plate (31) and remove the seal plate. Press the oil seal (71) from the seal plate.

## Separating Intermediate And Drive Assembly From Engine

### (Figure 3)

If necessary to separate the intermediate and drive assemblies from the engine, support the intermediate using a hoist and sling, and remove the hardware (1, 2, 12 and 13) securing the intermediate (14) to the engine bellhousing. Separate the assemblies by pulling the intermediate straight away from the engine.

As the assemblies are separated, the drive pins (6) will disengage from the drive arm assembly (8). The drive arm assembly and the impeller shaft key (7) are a tight press fit on the shaft (15), and will remain on the shaft.

It is not necessary to remove the drive plate assembly (5) from the engine flywheel unless the drive pins are bent or worn and must be replaced. To remove the drive plate assembly, remove the hardware (10 and 11) securing the assembly to the engine flywheel, and remove the drive plate.

The drive pins are secured into the drive plate by a tight press fit and peening. To remove the pins, drill through from the peened end and drive the pins out using a drift pin.

Use a bearing puller to remove the drive arm assembly from the impeller shaft. Remove the shaft key.

Inspect the dyna flex joints (9), and replace them if worn. The dyna flex joints are a press fit in the drive arm.

## Impeller Shaft And Bearing Disassembly

### (Figure 2)

When the pump is properly operated and maintained, the intermediate should not require disassembly. Disassemble the shaft and bearings **only** when there is evidence of wear or damage.

CAUTION

Shaft and bearing disassembly in the field is not recommended. These operations should be performed only in a properly-equipped shop by qualified personnel.

Drain the bearing lubricant by removing the intermediate drain plug (27). Clean and reinstall the drain plug.

Remove the hardware (19) securing the bearing cap (24) to the intermediate (26), and remove the bearing cap, gasket (18), outboard oil seal (23), and wavy washer (25).

Place a block of wood against the impeller end of the shaft (72), and tap the shaft and assembled bearings out of the intermediate. Press the inboard oil seal (28) from the intermediate.

Use a bearing puller to remove the inboard and outboard bearings (16 and 17) from the impeller shaft.

Impeller Shaft And Bearing Reassembly

(Figure 2)

Clean the bore of the intermediate, all component parts, and the impeller shaft with a soft cloth soaked in cleaning solvent. Inspect the parts for wear, and replace as necessary.

WARNING

```

////////////////////////////////////
//                               //
// Most cleaning solvents are toxic and flammable. Use //
// them only in a well-ventilated area free from excessive //
// heat, sparks, and flame. Read and follow all prec- //
// autions printed on solvent containers.                //
//                               //
////////////////////////////////////

```

Inspect the shaft for damaged threads, distortion, or nicks and scratches. Dress small nicks and burrs with a fine file or honing stone. Replace the impeller shaft if severely damaged.

To prevent contamination, wash the bearings separately in **fresh** cleaning solvent. Dry the bearings with filtered compressed air and coat with light oil for ease of reassembly.

Rotate the bearings by hand to check for roughness or binding. If rotation is rough, replace the bearings.

---

---

**CAUTION**

Bearings must be kept free of all dirt and foreign material. Failure to do so will greatly shorten bearing life. DO NOT spin dry bearings. This may scratch the balls or races and cause premature bearing failure.

The bearing tolerances provide a tight press fit onto the impeller shaft, and snug push fit into the intermediate. If the bearings slip on and off easily, the shaft is worn and must be replaced. The intermediate must be replaced if the bearings do not fit snugly.

Dip the bearings in clean oil and then position them on the shaft. The loading grooves on the inboard bearing **must** face toward the impeller. Using an arbor press, press against the inner races until the bearings seat squarely against the shaft shoulders.

**CAUTION**

When installing the bearings onto the shaft, NEVER press or hit against the outer race, balls, or ball cage. Press ONLY on the inner race.

Slide the shaft and assembled bearings into the intermediate bore until the inboard bearing (16) bottoms against the bore shoulder.

**CAUTION**

When installing the shaft and bearings into the bearing bore, push against the outer race. NEVER hit the balls or ball cage.

Install the wavy washer (25) and bearing cap gasket (18), then secure the bearing cap (24) to the intermediate.

Apply a light coat of oil on the outboard and inboard oil seals (23 and 28) and install them with the lips positioned as shown in Figure 1.

Lubricate the bearings as indicated in **LUBRICATION** at the end of Section E.

---

---

## Securing Intermediate And Drive Assembly To Engine

### (Figure 3)

Secure the drive plate assembly to the engine flywheel. If the drive pins were removed from the drive plate assembly, install new pins by pressing them into the drive plate and peening the ends.

Install the impeller shaft key and press the drive arm assembly on the impeller shaft.

### CAUTION

Make certain that the drive plate and drive arm assemblies are mounted in accordance with the dimensions shown in Figure 3. If the drive assembly is not properly positioned on the impeller shaft, a preload condition can occur and cause premature bearing failure.

Align the drive arm assembly so that the drive pins will engage the dyna flex joints, and secure the intermediate and intermediate guards to the engine bellhousing.

## Pump Reassembly

### (Figure 2)

Apply a light coat of oil on the oil seal (71) and press the oil seal into the seal plate with the lips positioned as shown in Figure 1. Slide the seal plate onto the shaft until fully seated against the intermediate. Align the threaded seal lubricant hole with the intermediate opening and temporarily secure the seal plate using two capscrews and nuts (1/2 UNC X 1 1/2 inch long, not supplied). Proceed to install the seal and impeller. See **Seal Reassembly and Impeller Reassembly And Adjustment**.

After the seal and impeller have been properly installed, remove the two capscrews temporarily holding the seal plate and install the same thickness of casing gaskets (9) as previously removed. Secure the seal plate and pump casing to the pedestal using nuts (11).

### NOTE

The front impeller clearance must be adjusted after pump casing and back cover are fully reassembled by adding or subtracting pump casing gaskets (9). Do not secure the pump casing to the base until this operation is done.

Seal Reassembly

(Figure 2 and 4)

Clean the seal cavity and shaft with a cloth soaked in fresh cleaning solvent.

WARNING

```

////////////////////////////////////
//
// Most cleaning solvents are toxic and flammable. Use //
// them only in a well-ventilated area free from excessive //
// heat, sparks, and flame. Read and follow all prec- //
// autions printed on solvent containers. //
// //
////////////////////////////////////

```

The seal is not normally reused because wear patterns on the finished faces cannot be realigned during reassembly. This could result in premature failure. If necessary to reuse an old seal in an emergency, **carefully** wash all metallic parts in fresh cleaning solvent and allow to dry thoroughly.

Handle the seal parts with extreme care to prevent damage. Be careful not to contaminate precision finished faces; even fingerprints on the faces can shorten seal life. If necessary, clean the faces with a non-oil based solvent and a clean lint free tissue. Wipe **lightly** in a concentric pattern to avoid scratching the faces.

Inspect the seal components for wear, scoring, grooves, and other damage that might cause leakage. Clean and polish the shaft sleeve, or replace it if there are nicks or cuts on either end. If any components are worn, replace the complete seal; **never mix old and new seal parts.**

If a replacement seal is being used, remove it from the container and inspect the precision finished faces to ensure that they are free of any foreign matter.

To ease installation of the seal, lubricate the O-rings and disc with water or a very **small** amount of oil, and apply a drop of light lubricating oil on the finished faces. Assemble the seal as follows, (see Figure 4).

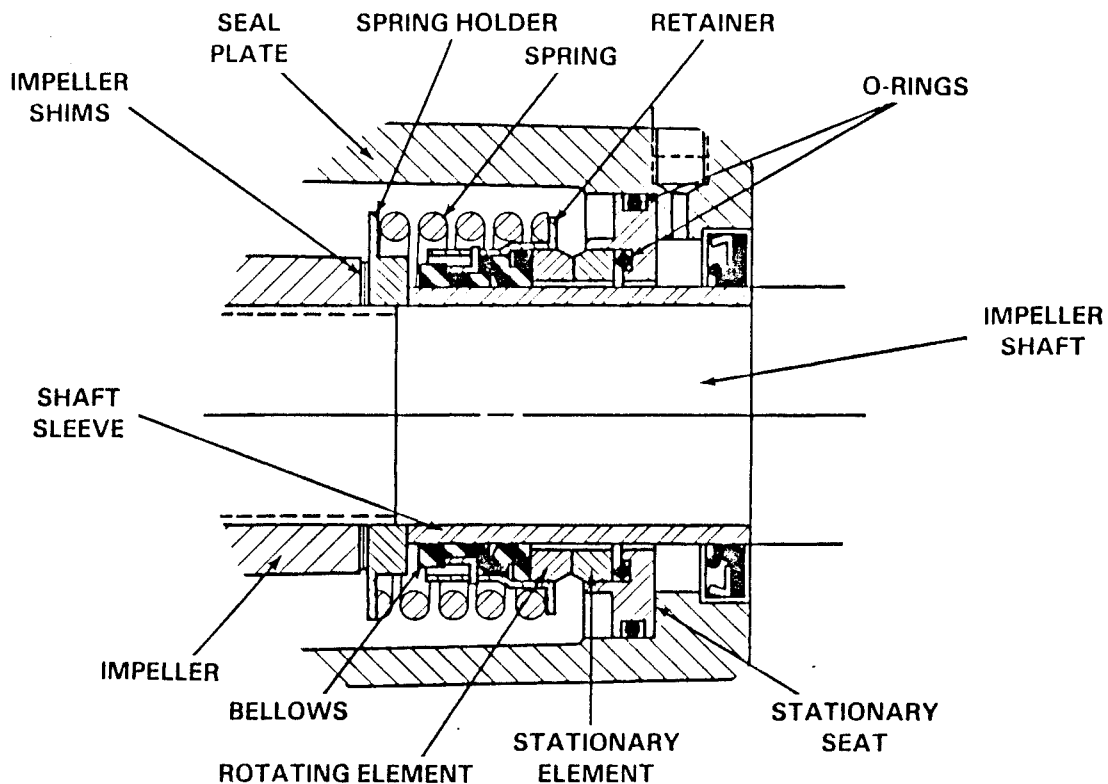

Figure 4. 12461 Seal Assembly

### CAUTION

This seal is not designed for operation at temperatures above 160°F. Do not use at higher operating temperatures.

Assemble the O-rings into the stationary element. Press the stationary element into the stationary seat with the chamfered side facing away from the seat. Press this assembly into the seal plate until the stationary seat bottoms against the seal plate bore. A push tube cut from a length of plastic pipe would aid this installation. The I.D. of the tube should be approximately the same as the I.D. of the seal spring.

Subassemble the rotating element in the retainer assembly with the chamfered side facing away from the retainer. Slide this assembly onto the shaft sleeve with the rotating element facing the chamfered end of the sleeve. Slide the sleeve onto the shaft until the seal elements contact and the sleeve bottoms against the shaft shoulder. Be careful not to damage the seal plate oil seal (28).

Install the spring and spring holder.

Reinstall the bottle oiler and piping (66, 67, and 68) and air vent and piping (12, 13 and 14).

---

---

Lubricate the seal as indicated in LUBRICATION, after the impeller has been installed.

### Impeller Reassembly And Adjustment

#### (Figure 2)

Inspect the impeller, and replace it if cracked or badly worn.

Slide the same number of impeller adjusting shims (30) as previously removed on to the shaft and screw the impeller on until tight.

A clearance of .025 to .040 inch between the impeller and the seal plate is necessary for maximum pump efficiency. Measure this clearance, and add or remove impeller shims until it is reached.

#### NOTE

If the pump has been completely disassembled, install a new pump casing gasket set and secure the pump casing to the intermediate at this time.

A clearance of .010 to .020 inch between the impeller and the wear plate is also recommended for maximum pump efficiency. This clearance must be set after installing the back cover, by adding or removing gaskets in the pump casing gasket set until the impeller binds against the wear plate when the shaft is turned. After the impeller binds, add .015 inch of gaskets.

#### NOTE

An alternate method of adjusting this clearance is to reach through the discharge port with a feeler gauge and measure the gap. Add or subtract pump casing gaskets accordingly.

### Suction Check Valve Installation

#### (Figure 2)

Inspect the check valve assembly, and replace it if badly worn.

#### NOTE

The check valve assembly must be replaced as a complete unit. Individual parts are not sold separately.

Reach through the back cover opening with the assembled check valve and position the check valve adaptor into the mounting slot in the seat. Align the adaptor with the seat hole and secure the assembly with the check valve pin (52).

---

---

**NOTE**

If the suction flange or check valve seat was removed, replace the respective gaskets and apply "Permatex Aviation #3 Form-A-Gasket" or equivalent to the mating surfaces.

**Back Cover Installation****(Figure 2)**

Inspect the wear plate (32) and replace it if badly worn or grooved. To remove the wear plate, disengage the hardware (33 and 34).

Clean any scale or debris from the back cover shoulder and pump casing which might prevent a good seal. Replace the back cover gasket (40) and slide the back cover assembly into the pump casing. Be sure the wear plate does not bind against the pump casing.

**NOTE**

To ease future disassembly, apply a film of grease or 'Never-Seez' on the back cover shoulder, or any surface which contacts the pump casing. This action will reduce rust and scale build-up.

Secure the back cover assembly by installing the clamp bar and tightening the cover clamp screw. **Do not** over tighten the clamp screw; it should be just tight enough to ensure a good seal at the back cover shoulder.

**Final Pump Reassembly****(Figure 1)**

**Be sure** the pump is secured to the base and engine.

Install the suction and discharge lines, and open all valves. Make certain that all piping connections are tight, properly supported and secure.

**Be sure** the pump end and engine have been properly lubricated, see LUBRICATION.

Fill the pump casing with clean liquid. Reinstall the fill cover plate and tighten it.

Refer to **OPERATION**, Section C, and start the pump.

---

---

## LUBRICATION

### Seal Assembly

Fill the bottle oiler (66, Figure 2) with SAE No. 30 non-detergent motor oil, making certain to vent the cavity at the air vent (12, Figure 2) while filling. Check the oil level regularly and keep the bottle oiler full.

### Bearings

The bearing housing was fully lubricated when shipped from the factory. Check the oil level regularly through the sight gauge (20, Figure 1) and maintain it at the mid-point of the gauge. When lubrication is required, add S.A.E. #30 non-detergent oil through the oil hole cover (15, Figure 2).

#### NOTE

The white reflector in the sight gauge must be positioned horizontally to provide proper drainage.

Under normal operating conditions, drain and refill the bearing housing once each year with clean oil. **Do not** over lubricate. Excessive oil could cause preloading and over-heating of the bearings.

For cold weather operation, consult the factory or a lubricant supplier for the recommended grade of oil.

### Engine

Refer to the engine manufacturer's recommendations.



**For U.S. and International Warranty Information,  
Please Visit [www.grpumps.com/warranty](http://www.grpumps.com/warranty)  
or call:  
U.S.: 419-755-1280  
International: +1-419-755-1352**

**For Canadian Warranty Information,  
Please Visit [www.grcanada.com/warranty](http://www.grcanada.com/warranty)  
or call:  
519-631-2870**