

**INSTALLATION, OPERATION, PARTS LIST,  
AND MAINTENANCE MANUAL**

---

A C E

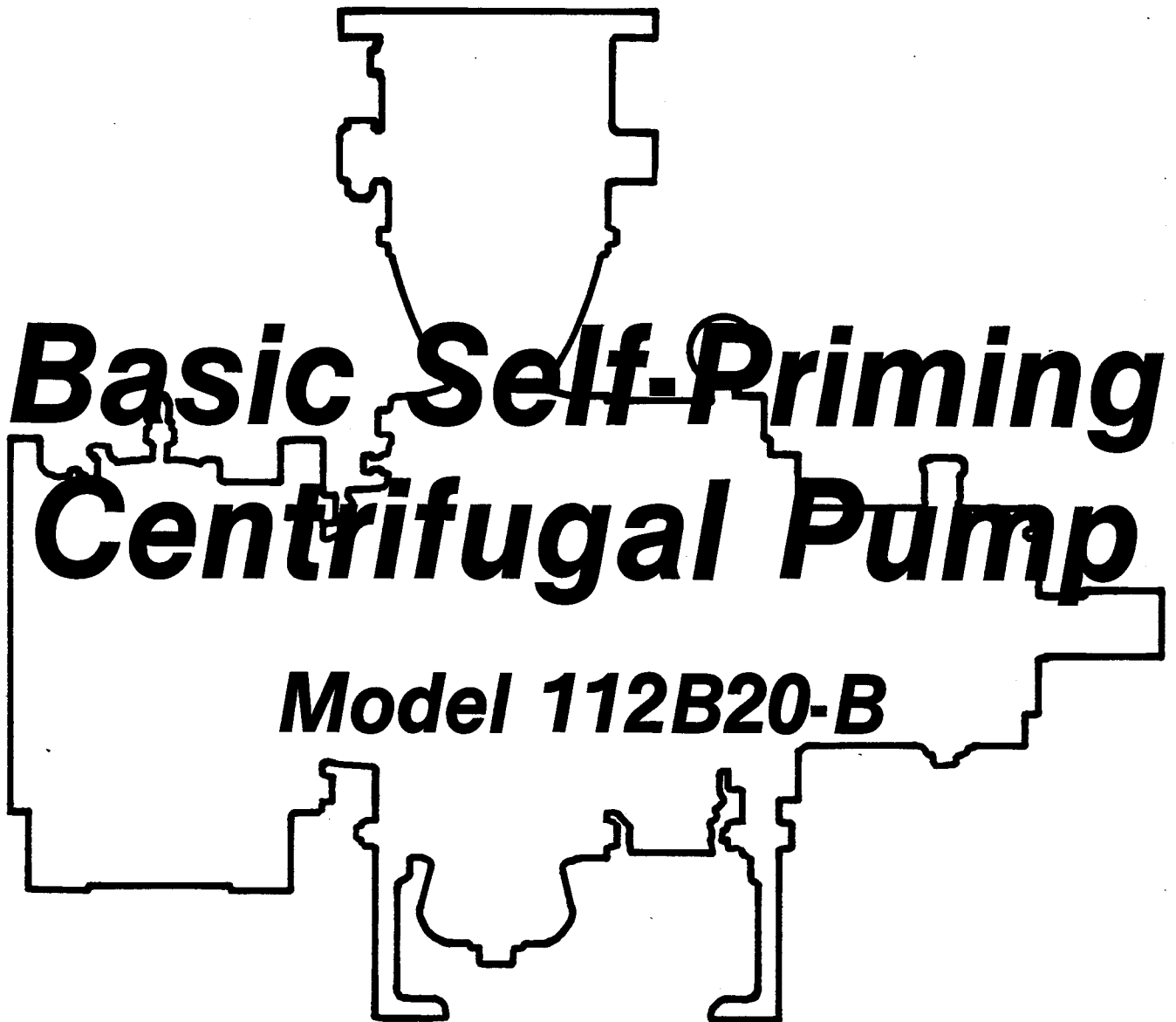

March 18, 1980

A large, black outline of a centrifugal pump housing is centered on the page. The outline shows the main body of the pump, including the inlet and outlet ports and the central impeller area. The text is overlaid on this outline.

***Basic Self-Priming  
Centrifugal Pump***

***Model 112B20-B***

**THE GORMAN-RUPP COMPANY • MANSFIELD, OHIO**

**GORMAN-RUPP OF CANADA LIMITED • ST. THOMAS, ONTARIO, CANADA** Printed in U.S.A.

Copyright by the Gorman-Rupp Company

This Installation, Operation, and Maintenance Manual is designed specifically to help you get the best performance and longest life from your Gorman-Rupp pump.

This pump is a 10 Series, semi-open impeller, self-priming centrifugal model designed for pumping liquids with specified entrained solids.

If there are any questions regarding the pump which are not covered in this manual or in other literature accompanying the unit, please contact your Gorman-Rupp distributor, or write:

The Gorman-Rupp Company	or	Gorman-Rupp of Canada Limited
P.O. Box 1217		70 Burwell Road
Mansfield, Ohio 44901		St. Thomas, Ontario N5P 3R7

For information or technical assistance on the power source, contact the power source manufacturer's local dealer or representative.

The following are used to alert maintenance personnel to procedures which require special attention, to those which could damage equipment, and to those which could be dangerous to personnel:

#### NOTE

Instructions to aid in installation, operation, or maintenance or which clarify a procedure.

#### CAUTION

Instructions which must be followed to avoid causing damage to the product or other equipment incidental to the installation. These describe the procedure required and the damage which could result from failure to follow the procedure.

#### WARNING

Instructions which must be followed to avoid causing injury or death to personnel. These describe the procedure required and the injury which could result from failure to follow the procedure.

#### TABLE OF CONTENTS

WARNINGS	Section A
INSTALLATION	Section B
OPERATION	Section C
TROUBLESHOOTING	Section D
MAINTENANCE AND REPAIR	Section E
WARRANTY	

## WARNINGS

THESE WARNINGS APPLY TO ALL BASIC PUMPS. GORMAN-RUPP HAS NO CONTROL OVER OR PARTICULAR KNOWLEDGE OF THE POWER SOURCE WHICH WILL BE USED. REFER TO THE MANUAL ACCOMPANYING THE POWER SOURCE BEFORE ATTEMPTING TO START THE POWER SOURCE.

Before attempting to open or service the pump:

1. Familiarize yourself with this manual.
2. Disconnect the power source to ensure that the pump will remain inoperative.
3. Allow the pump to cool if overheated.
4. Vent the pump slowly and cautiously.
5. Close the suction and discharge valves.
6. Check the temperature before opening any covers, plates, or plugs.
7. Drain the pump.

Do not attempt to pump volatile or corrosive materials for which this pump has not been designed.

After the pump has been located in its operating position, make certain that the pump has been secured before attempting to operate it.

Do not operate the pump without shields and/or guards in place over drive shafts, belts and/or couplings, or other rotating parts. Exposed rotating parts can catch clothing, fingers, or tools, causing severe injury to personnel.

Do not operate the pump against a closed discharge valve for long periods of time. This could bring the liquid to a boil, build pressure, and cause the pump to rupture or explode.



Overheated pumps can cause severe burns and injury. If overheating of the pump casing occurs:

1. Stop the pump immediately.
2. Allow the pump to cool.
3. Refer to instructions in this manual before restarting the pump.

Do not remove plates, covers, gauges, pipe plugs, or fittings from an overheated pump. Vapor pressure within the pump can cause parts being disengaged to be ejected with great force. Allow the pump to cool before servicing.

# INSTALLATION

Seldom are two pump installations identical. The information presented in this section is a summary of the recommended installation practices related to inspection, pump positioning, hardware, suction and discharge piping, and sumps. For further assistance, contact your Gorman-Rupp distributor or the Gorman-Rupp Company.

## PREINSTALLATION INSPECTION

The pump assembly was inspected and tested before it was shipped from the factory. Before installation, inspect the pump for damage which may have occurred during shipment. Check as follows:

- a. Inspect the pump assembly for cracks, dents, damaged threads, and other obvious damage.
- b. Check for and tighten loose bolts, nuts, capscrews, and other attaching hardware. Since gaskets tend to shrink after drying, check for and tighten loose nuts and capscrews securing mating surfaces.
- c. Carefully read all tags, decals, and markings on the pump assembly, and perform all duties indicated. Note the direction of rotation indicated on the pump. Check that the pump shaft rotates in the required direction.

### CAUTION

Only operate this pump in the direction indicated by the arrow on the pump body and on the accompanying decal. Otherwise, the impeller could become loosened from the shaft and seriously damage the pump.

- d. Check all lubricant levels and lubricate as necessary. Refer to the MAINTENANCE AND REPAIR section of this manual.

## POSITIONING THE PUMP

### Mounting

Locate the pump in an accessible place as close as practical to the liquid to be pumped. Level mounting is essential for proper operation. The pump may have to be supported to provide for level operation or to eliminate vibration.



## Lifting

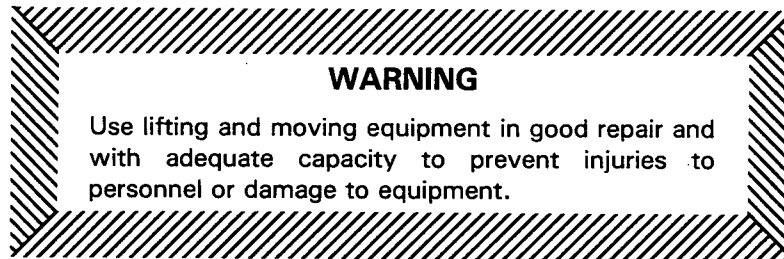

Make sure that hoists and other lifting equipment are of sufficient capacity to safely handle the pump assembly. If chains and cables are used, make certain that they are positioned so that they will not damage the pump, and so that the load will be balanced.

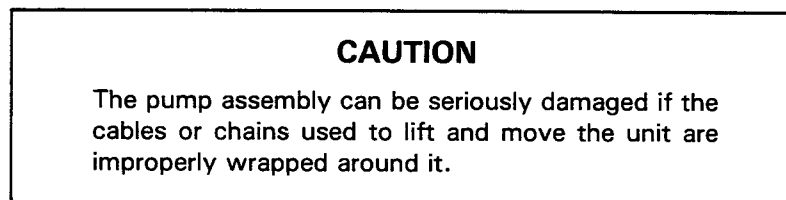

## SUCTION AND DISCHARGE PIPING

### Materials

Either pipe or hose may be used for suction and discharge lines, but hose used in suction lines must be the rigid-wall, reinforced type to prevent collapse under suction. Using pipe couplings in suction lines is not recommended.

### Line Configuration

Keep suction and discharge lines as straight as possible to minimize friction losses. Make minimum use of elbows and fittings, which substantially increase friction loss. If elbows are necessary, use the long-radius type to minimize friction loss.

### Connections to Pump

Never pull a pipe line into place by tightening the flange bolts. The connecting flange must be aligned exactly with the pump port. Lines near the pump must be independently supported to avoid strain on the pump which could cause serious vibration, decreased bearing life, and increased shaft and seal wear. Hose-type lines should have supports strong enough to secure the line when it is filled with liquid and under pressure.

### Gauges

Most pumps are drilled and tapped for installing discharge pressure and vacuum suction gauges. If these gauges are desired for pumps that are not tapped, drill and tap the suction and discharge lines close to the pump before installing the lines.

## SUCTION LINES

To avoid air pockets which could affect pump priming, the suction line must be as short and direct as possible. When operation involves a suction lift, the line must always slope upward to the pump from the source of the liquid being pumped; if the line slopes down to the pump at any point along the suction run, air pockets will be created.

### Fittings

Suction lines should be the same size as the pump inlet. If reducers are used in suction lines, they should be the eccentric type, and should be installed with the flat part of the reducers uppermost to avoid creating air pockets. Valves are not normally used in suction lines, but if a valve is used, install it with the stem down or to either side to avoid air pockets.

### Strainers

Install a strainer at the end of the suction line to avoid possible clogging or damage to the pump. The total area of the openings in the strainer should be at least three or four times the cross section of the suction line, but no opening should be larger than the solids handling capability of the pump. Clean the strainer regularly during operation.

### Sealing

All connections in the suction line should be sealed with pipe dope to ensure an airtight seal. Even a slight leak will affect priming, head, and capacity, especially when operating with a high suction lift. After installation, inspect the suction line carefully for potential leaks.

## DISCHARGE LINES

### Throttling Valves

If a throttling valve is desired, install it in the discharge line. Use a valve as large as the largest pipe in the line to minimize friction losses. Never install a throttling valve in the suction line.

### Check Valves

A check valve in the discharge line is normally recommended, but is not necessary in low discharge head applications.

With high discharge heads, install a throttling valve and a check valve in the discharge line to protect the pump from excessive shock pressure and reverse rotation when it is stopped.

### Bypass Lines

If it is necessary to permit the escape of air to atmosphere during initial priming or in the repriming cycle, install a bypass line between the pump and the discharge check valve. The bypass line should be sized so that it does not affect pump discharge capacity.

Either a Gorman-Rupp automatic air release valve—which will automatically open to allow the pump to prime, and automatically close when priming is accomplished—or a hand-operated shutoff valve should be installed in the bypass line.



**NOTE**

The bypass line may clog frequently, particularly if the valve remains closed. If this condition occurs, either use a larger bypass line or leave the shutoff valve open during the pumping operation.

Do not terminate the discharge line at a level lower than that of the liquid being pumped unless a siphon breaker is used in the line. Otherwise, a siphoning action could result, causing damage to the pump.

**SUCTION LINE POSITIONING**

The depth of submergence of the suction line is critical to efficient pump operation. Figure 1 shows recommended minimum submergence vs. velocity.

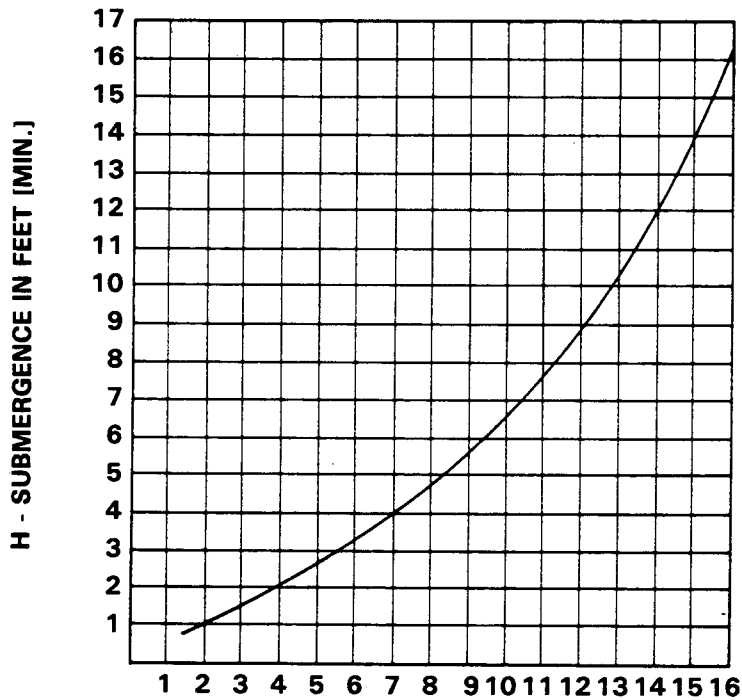

$$\text{VELOCITY IN FEET PER SEC.} = \frac{\text{QUAN. [G.P.M.] x .321}}{\text{AREA}} \text{ OR } \frac{\text{G.P.M. x .4085}}{D^2}$$

Figure 1. Recommended Minimum Suction Line Submergence Vs. Velocity

**Single Suction Lines**

Install a single suction line a distance from the wall of the sump equal to one and one-half the size of the suction line. Liquid flow into a sump should never enter near the pump suction inlet because inflow will carry air down into the sump, and air entering the suction line will reduce pump efficiency.



If it is necessary to position an inflow pipe close to the suction inlet, install a baffle a distance from the suction inlet equal to one and one-half the size of the suction line (see figure 2). This baffle will allow entrained air to escape before the liquid is drawn into the suction line.

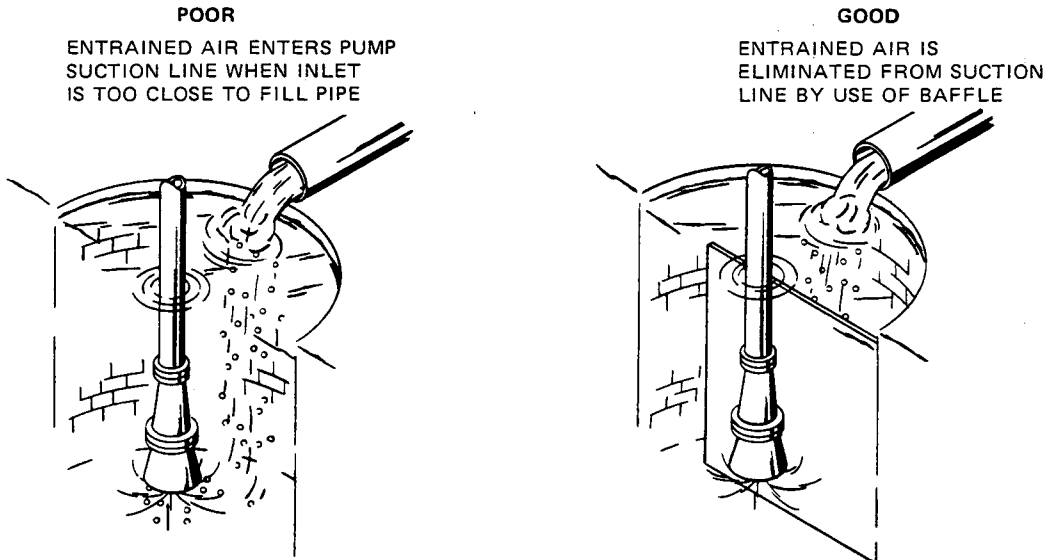

Figure 2. Eliminating Entrained Air Caused by a Fill Pipe

**Multiple Suction Lines**

When two suction lines are installed in one sump, separate the inlets by at least three times the diameter of the suction pipe. If the suction inlets are too close together, the flow paths may interact, reducing the efficiency of one or both pumps (see figure 3).

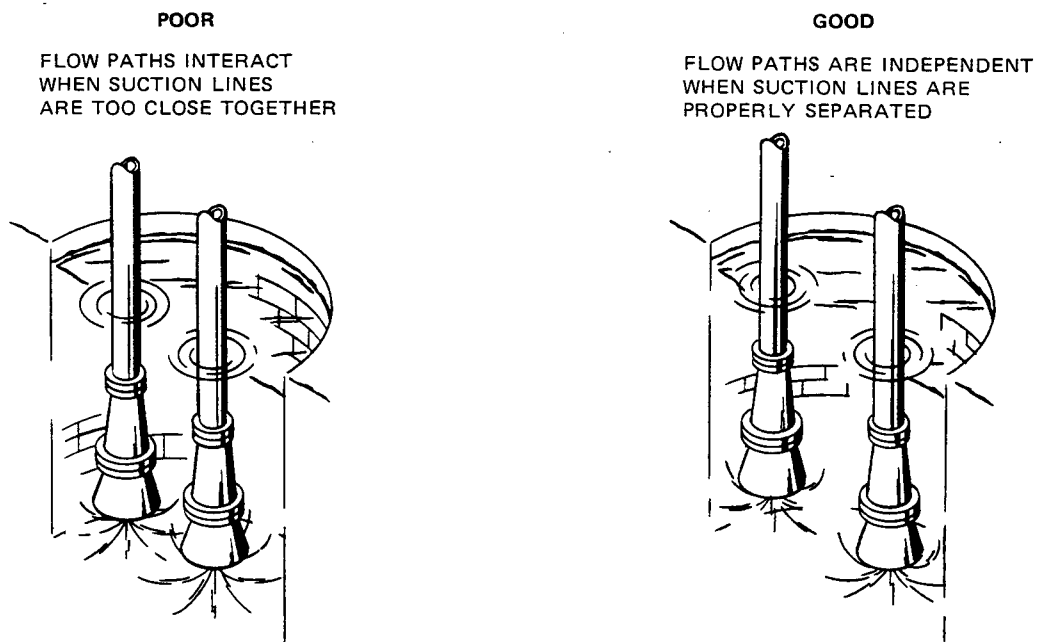

Figure 3. Using Two Pumps in the Same Sump

## ALIGNMENT

The alignment of the pump and its power source is critical for trouble-free mechanical operation. In either a flexible coupling or V-belt driven system, the driver and pump must be mounted so that their shafts are aligned with a parallel to each other.

### NOTE

When mounted at the Gorman-Rupp factory, driver and pump are aligned before shipment. Misalignment can occur in transit and handling, however, and pumps should be checked, and realigned if necessary, before being put into operation.

Before checking alignment, tighten the foundation bolts. The pump casing feet and/or pedestal feet, and the driver mounting bolts should also be tightly secured.

### WARNING

When checking alignment, disconnect the power source to ensure that the pump will remain inoperative.

### Aligning Coupling Driven Pumps

In coupling applications, the axis of the drive unit must be aligned to the axis of the pump shaft in both the horizontal and vertical planes. Most couplings require a specific gap or clearance between the driving and the driven shafts. Refer to the coupling manufacturer's service literature for information.

To check non-spider type couplings, use a feeler gauge or a taper gauge between the coupling halves every 90 degrees. The coupling is in alignment when the hubs are the same distance apart at all points (see figure 5A).

To check spider insert type couplings, use calipers to measure the dimensions on the circumference of the outer ends of the coupling hub every 90 degrees. The coupling is in alignment when the hub ends are the same distance apart at all points (see figure 5B).



Figure 5A. Aligning Non-Spider Type Couplings

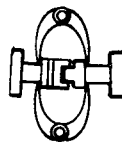

Figure 5B. Aligning Spider-Type Couplings

To check parallel adjustment, lay a straightedge across both coupling rims at the top, bottom, and side. The coupling is in horizontal parallel alignment when the straightedge rests evenly on both halves of the coupling. Use a feeler gauge between the coupling and the straightedge to measure the amount of misalignment.

Coupling and alignment adjustments may be made by loosening the hold-down bolts and shifting the driver and pump, or by shimming as required.

**CAUTION**

Adjusting the alignment in one direction may alter the alignment in another direction. Check each procedure after altering alignment.

**Aligning V-Belt Driven Pumps**

If V-belts and pulleys connect the drive unit to the pump, the unit and the pump must be parallel and the pulleys properly aligned. Use a straightedge along the sides of the pulleys to ensure alignment. For drive systems that employ two or more belts, make sure that the belts are a matched set; unmatched sets will result in accelerated belt wear (see figure 5C).



**MISALIGNED: SHAFTS NOT PARALLEL**



**MISALIGNED: SHEAVES NOT IN LINE**



**ALIGNED: SHAFTS PARALLEL AND SHEAVES IN LINE**

**Figure 5C. Alignment of V-Belt Driven Pumps**

Tighten the belts in accordance with the belt manufacturer's instructions. The belts will slip if they are too loose; there will be excessive power loss and possible bearing failure if they are too tight. Select pulleys that will provide the proper speed ratio. Overspeeding the pump may damage both pump and driver.

**Drive Shaft Guards**

Driver and shaft assemblies, couplings, and belts and sheaves mounted at the Gorman-Rupp factory are supplied with a guard for protection of personnel. Do not operate the pump without a guard.

**WARNING**

Do not operate the pump without a guard over the rotating parts. Exposed rotating parts can catch clothing, fingers, or tools, causing severe injury to personnel.



## OPERATION

### WARNING

Do not attempt to pump volatile or corrosive materials for which this pump has not been designed.

### PRIMING

Install the pump and piping as described in INSTALLATION. Make sure that the piping connections are tight, and that the pump is securely mounted. Check that the pump is properly lubricated (see LUBRICATION in MAINTENANCE AND REPAIR).

This pump is self priming, but the pump volute casing must first be filled with liquid if:

1. The pump is being put into service for the first time.
2. The pump has not been used for a considerable length of time.
3. The liquid in the volute casing has evaporated.

Once the volute casing has been filled, the pump will prime and reprime as necessary.

### CAUTION

Never operate a self-priming pump unless the volute is filled with liquid. The pump will not prime when dry. Extended operation of a dry pump will destroy the seal assembly.

To fill the pump, remove the volute fill cover or fill plug at the top of the casing and add clean liquid until the pump is filled. Replace the fill cover or fill plug before operating the pump.

### STARTING

Consult the operating manual furnished with the power source.

### Rotation

The correct direction of pump rotation is indicated by an arrow on the pump body and on the accompanying decal. If the pump is operated in the wrong direction, the impeller could become loosened and the pump damaged.

**CAUTION**

Only operate this pump in the direction indicated by the arrow on the pump body and on the accompanying decal. Otherwise, the impeller could become loosened from the shaft and seriously damage the pump.

When checking the rotation of a pump driven by a three-phase electric motor, start the pump for a moment to see if the rotation is correct. If the shaft, coupling, or V-belt is not visible, rotation can usually be determined by observing the motor cooling fan. If the rotation is incorrect, have qualified personnel interchange any two of the three-phase wires to change direction.

**Lines With a Bypass**

Either a Gorman-Rupp automatic air release valve or a hand operated shutoff valve may be installed in a bypass line.

If a Gorman-Rupp automatic air release valve has been installed, close the throttling valve in the discharge line. The Gorman-Rupp valve will automatically open to allow the pump to prime, and automatically close when priming has been accomplished. After the pump has been primed, and liquid is flowing steadily from the bypass line, open the discharge throttling valve.

If a hand operated shutoff valve has been installed, close the throttling valve in the discharge line, and open the bypass shutoff valve so that the pump will not have to prime against the weight of the liquid in the discharge line. When the pump has been primed, and liquid is flowing steadily from the bypass line, close the bypass shutoff valve and open the discharge throttling valve.

**Lines Without a Bypass**

Open all valves in the discharge line and start the power source. Priming is indicated by a positive reading on the discharge pressure gauge or by quieter operation. The pump may not prime immediately because the suction line must first fill with liquid. If the pump fails to prime within five minutes, stop it and check the suction line for leaks.

After the pump has been primed, partially close the discharge line throttling valve in order to fill the line slowly and guard against excessive shock pressure which could damage pipe ends, gaskets, sprinkler heads, and any other fixtures connected to the line. When the discharge line is completely filled, adjust the throttling valve to the required discharge flow rate.

**Leakage**

No leakage should be visible at pump mating surfaces, or at pump connections or fittings. Keep all line connections and fittings tight to maintain maximum pump efficiency.

**Overheating**

Overheating can occur if the valves in the suction or discharge lines are closed. Operating against closed valves could bring the liquid to a boil, build pressure, and cause the pump to rupture or explode. If overheating occurs, stop the pump and allow it to cool before servicing it. Refill the volute casing with cool liquid.



**WARNING**

Do not remove plates, covers, gauges, pipe plugs, or fittings from an overheated pump. Vapor pressure within the pump can cause parts being disengaged to be ejected with great force. Allow the pump to cool before servicing.

**Strainer Check**

Check the suction strainer regularly during pump operation, or if the pump flow rate begins to drop, and clean it as necessary. Be especially alert for unusual noises when pumping liquids containing solids.

**Pump Vacuum Check**

Install a vacuum gauge in the system, using pipe dope on the threads.

The pump should pull a vacuum of 20 inches or more of mercury at operating speed with the suction line blocked. If it does not, check for air leaks in the seal or gaskets.

With the pump primed and at operating speed, and the suction line open, read the vacuum gauge. Shut off the pump, keep the vacuum line open, and read the gauge again to see if the vacuum remains at the maximum developed by the pump. If the vacuum falls off rapidly, an air leak exists. If the liquid level at the source of supply remains at a constant level, check to make certain that the air leak is not from the vacuum gauge connection.

**STOPPING**

After stopping the pump, disconnect the power source to ensure that the pump will remain inoperative.

In below freezing conditions, drain the pump to prevent damage from freezing. Also, clean out any solids by flushing with a hose. Operate the pump for approximately one minute; this will remove any remaining liquid that could freeze the pump rotating parts.

If the pump will be idle for more than a few hours, or if it has been pumping liquids containing a large amount of solids, drain the pump, and flush it thoroughly with clean water. To prevent large solids from clogging the drain port and preventing the pump from completely draining, operate the pump during the draining process. Clean out any remaining solids by flushing with a hose.

### **BEARING TEMPERATURE CHECK**

Bearings normally run at higher than ambient temperatures because of heat generated by friction. Temperatures up to 160°F are considered normal for pedestal bearings, and they can operate safely to at least 180°F.

Checking bearing temperatures by hand is inaccurate. They can be measured accurately by placing a contact-type thermometer against the housing. Record this temperature for future reference.

A sudden increase in bearing temperatures is a warning that the bearings are at the point of failing to operate properly. Make certain that the bearing lubricant is of the proper viscosity and at the correct level (see LUBRICATION in MAINTENANCE AND REPAIR). Bearing overheating can also be caused by shaft misalignment and/or excessive vibration.

When pumps are first started, the bearings may seem to run at temperatures above normal. Dynamic operation will bring the temperatures down to normal levels.



## TROUBLESHOOTING

### WARNING

Before attempting to open or service the pump:

1. Consult pump service manual.
2. Disconnect the power source to ensure that the pump will remain inoperative.
3. Allow pump to cool if overheated.
4. Close suction and discharge valves.
5. Drain pump.

Trouble	Possible Cause	Probable Remedy
PUMP FAILS TO PRIME	<p>Air leak in suction line.</p> <p>Lining of suction hose collapsed.</p> <p>Suction check valve clogged or binding.</p> <p>Leaking or worn seal or pump gasket.</p> <p>Suction lift or discharge head too high.</p> <p>Suction strainer clogged.</p>	<p>Correct leak.</p> <p>Replace suction hose.</p> <p>Clean valve.</p> <p>Check pump vacuum. Replace leaking or worn seal or gasket.</p> <p>Check piping installation and install bypass line if needed. See <b>INSTALLATION</b>.</p> <p>Clean suction strainer.</p>
PUMP STOPS OR FAILS TO DELIVER RATED FLOW OR PRESSURE	<p>Air leak in suction line.</p> <p>Suction intake not submerged at proper level or sump too small.</p> <p>Lining of suction hose collapsed.</p> <p>Impeller or other wearing parts worn or damaged.</p> <p>Impeller clogged.</p> <p>Pump speed too slow.</p> <p>Discharge head too high.</p> <p>Suction lift too high.</p>	<p>Correct leak.</p> <p>Check installation and correct as needed. Check submergence chart (Section B, page 4).</p> <p>Replace suction hose.</p> <p>Check impeller clearance. Replace worn parts as needed.</p> <p>Free impeller of debris.</p> <p>Check driver output; check belts or couplings for slippage.</p> <p>Install bypass line.</p> <p>Reduce suction lift.</p>



Trouble	Possible Cause	Probable Remedy
PUMP STOPS OR FAILS TO DELIVER RATED FLOW OR PRESSURE (cont)	<p>Leaking or worn seal or pump gaskets.</p> <p>Suction strainer clogged.</p>	<p>Check pump vacuum. Replace leaking or worn seal or pump gaskets.</p> <p>Clean suction strainer.</p>
PUMP REQUIRES TOO MUCH POWER	<p>Pump speed too high.</p> <p>Discharge head too low.</p> <p>Liquid solution too thick.</p>	<p>Check driver output; check that sheaves or couplings are correctly sized.</p> <p>Adjust discharge valve.</p> <p>Dilute if possible.</p>
PUMP CLOGS FREQUENTLY	<p>Discharge flow too slow.</p> <p>Suction check valve clogged or binding.</p>	<p>Open discharge valve fully to increase flow rate, and run engine at maximum governed speed.</p> <p>Free valve, and clean or replace it.</p>
EXCESSIVE NOISE	<p>Cavitation in pump.</p> <p>Pumping entrained air.</p> <p>Pump or drive not securely mounted.</p> <p>Impeller clogged or damaged.</p>	<p>Reduce suction lift and/or friction losses in suction line.</p> <p>Locate and eliminate source of air bubble.</p> <p>Secure mounting hardware.</p> <p>Clean out debris; replace damaged parts.</p>
BEARINGS RUN TOO HOT	<p>Bearing temperature is high, but within limits.</p> <p>Low or incorrect lubricant.</p> <p>Suction and discharge lines not properly supported.</p> <p>Drive misaligned.</p>	<p>Check bearing temperature.</p> <p>Check for proper type and level of lubricant.</p> <p>Check piping installation for proper support.</p> <p>Align drive properly.</p>

# ***Basic Self-Priming Centrifugal Pump***

## ***Model 112B20-B***

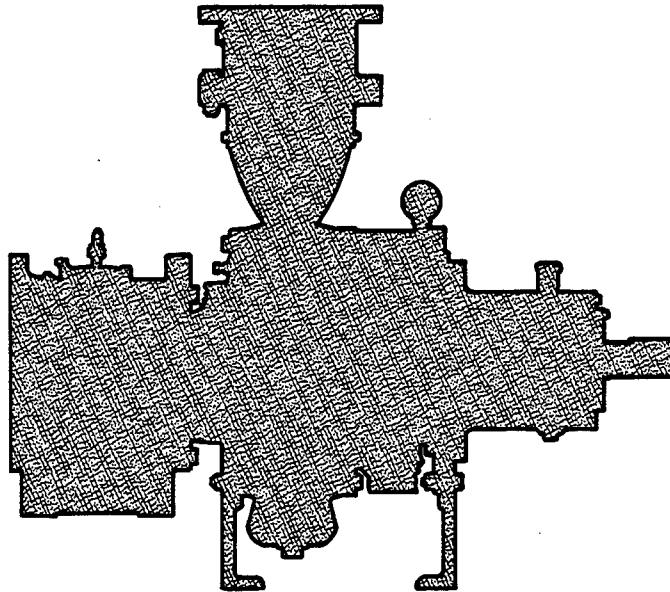

The only moving parts of this pump are the impeller, seal rotating elements, and the shaft. The wear plate, impeller, and seal, which receive the most wear, are easily accessible and can be replaced by removing the cover without disturbing the volute casing and piping. Maintenance and replacement of these three parts will maintain the peak operating efficiency of the pump.

# SECTIONAL DRAWING

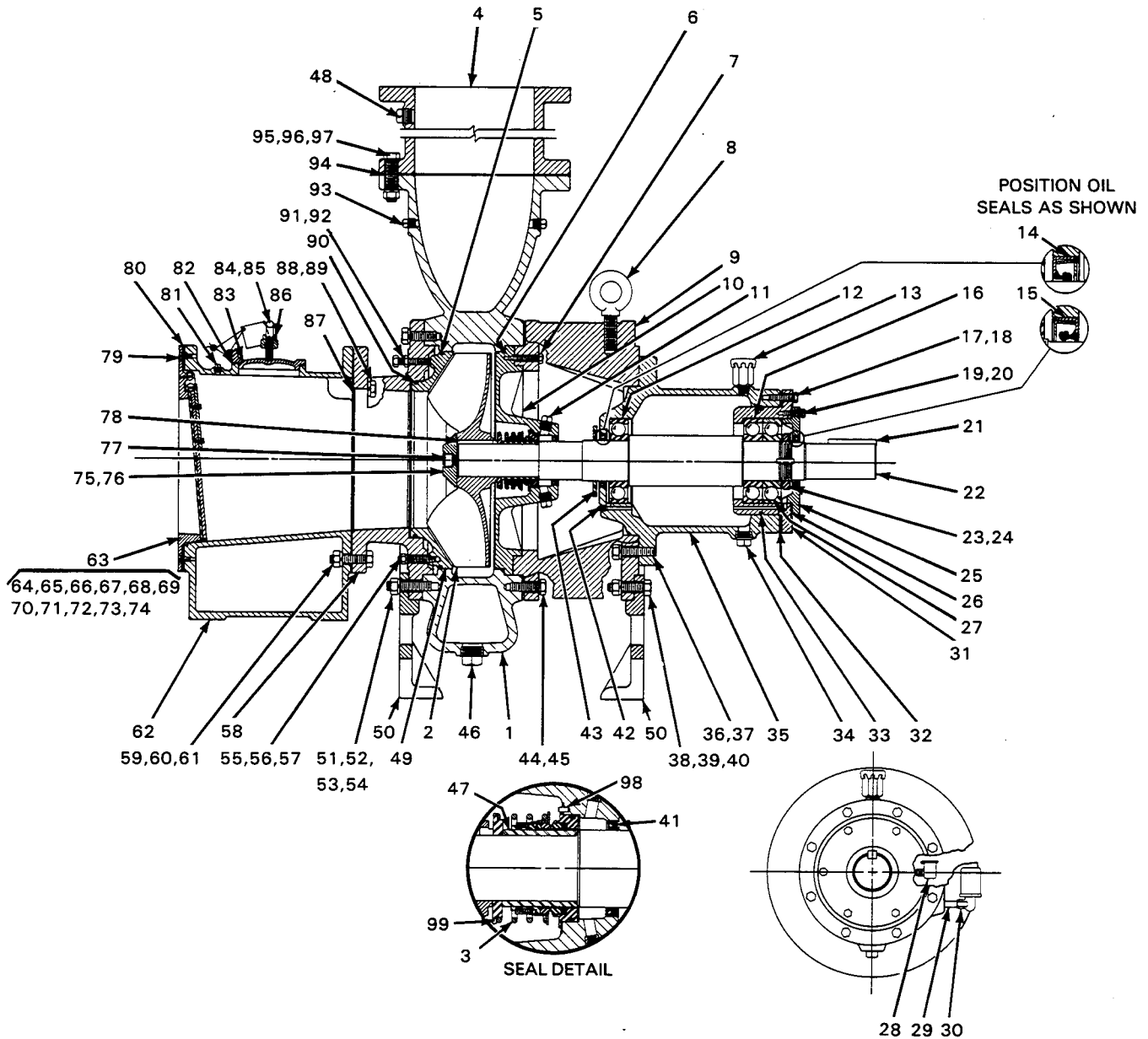

Figure 1. Pump Model 112B20-B



## PARTS LIST

ITEM NO.	MODEL 112B20-B PART NAME	PART NUMBER	MATL CODE	QTY	ITEM NO.	MODEL 112B20-B PART NAME	PART NUMBER	MATL CODE	QTY
1	VOLUTE CASING	38222-702		1	53	STUD	C-1215	15991	4
2	★IMPELLER	38615-702		1	54	HEX NUT	D-12	15991	4
3	★SEAL ASSEMBLY	46512-007		1	55	STUD	C-0814	15991	4
4	SPOOL FLANGE	38642-605		1	56	LOCKWASHER	J-08	15991	4
5	★O-RING	25152-283		1	57	HEX NUT	D-08	15991	4
6	★O-RING	25152-283		1	58	SUCTION HEAD	38246-610		1
7	HEX HEAD CAPSCREW	B-0610	15991	2	59	HEX HEAD CAPSCREW	B-1413	15991	10
8	EYE BOLT	NOT FURNISHED			60	LOCKWASHER	J-14	15991	10
9	INTERMEDIATE	38264-701		1	61	HEX NUT	D-14	15991	10
10	★SEAL PLATE	38272-702		1	62	FLAP VALVE FLANGE	14270-A	10010	1
11	SEAL CAVITY PLUG	P-04	11990	2	63	★CHECK VALVE ASSEMBLY	14284		1
12	★BALL BEARING	23275-018		1	64	CHECK VALVE SHAFT	14282	17010	2
13	★PEDESTAL AIR VENT	S-1703		1	65	BEARING PIVOT	14274	17070	2
14	★OIL SEAL	25227-931		1	66	DRY SLEEVE BEARING	S-2282		4
15	★OIL SEAL	25227-884		1	67	GROOVED PIN	21142-433		4
16	★BALL BEARING	23413-418		1	68	FLANGED SEAT	14273-A	10010	1
17	HEX HEAD CAPSCREW	B-0808	15991	8	69	BUTTON HEAD CAPSCREW	CM-0404	15990	2
18	LOCKWASHER	J-08	15991	8	70	BUTTON HEAD CAPSCREW	CM-0403	15990	2
19	HEX HEAD CAPSCREW	B-0605	15991	6	71	HEX HEAD CAPSCREW	B-0402	15991	4
20	LOCKWASHER	J-06	15991	6	72	LOCKWASHER	J-04	15991	4
21	★SHAFT KEY	N-1216	15990	1	73	VALVE PLATE	14283	15990	1
22	★IMPELLER SHAFT	38512-514		1	74	VALVE ASSEMBLY MOLD	14281	24010	1
23	BEARING LOCKNUT	23962-018		1	75	★IMPELLER WASHER	31167-012		1
24	LOCKWASHER	23962-518		1	76	★IMPELLER ROLL PIN	S-2197		1
25	★BEARING CAP	38322-416		1	77	★IMPELLER CAPSCREW	BD-1206	15990	1
26	★BEARING CAP GASKET SET	48211-041		1	78	★IMPELLER KEY	N-1012	15990	1
27	★BALL BEARING	23413-418		1	79	FLT SCH CAPSCREW	F-0404	15990	2
28	SEAL OIL CUP	S-0617		1	80	★CHECK VALVE FLNG GSKT	14273-G	20000	1
29	NIPPLE	T-0408	15070	1	81	ACCESSORY PLUG	P-04	11990	1
30	★PEDESTAL BOTTLE OILER	26713-025		1	82	★FILL COVER GASKET	12369-G	20000	1
31	BEARING HOUSING	38331-603		1	83	FILL COVER PLATE ASSY	48271-020		1
32	★BEARING SHIM SET	48261-030		16	84	HEX HEAD CAPSCREW	B-0808	15991	2
33	★O-RING	25152-266		1	85	FILL COVER CLAMP SCREW	8618	24000	1
34	PEDESTAL DRAIN PLUG	P-12	11990	1	86	FILL COVER CLAMP BAR	12370	11000	1
35	PEDESTAL	38251-507		1	87	SUCTION HEAD GASKET	14273-G	20000	1
36	HEX HEAD CAPSCREW	B-1211	15991	4	88	HEX HEAD CAPSCREW	B-1410	15991	2
37	LOCKWASHER	J-12	15991	4	89	LOCKWASHER	J-14	15991	2
38	HEX HEAD CAPSCREW	B-1212	15991	4	90	★O-RING	25152-278		1
39	LOCKWASHER	J-12	15991	4	91	WEAR PLATE ADJ SCREW	31871-040		4
40	HEX NUT	D-12	15991	4	92	WEAR PLATE JAM NUT	AT-08	15991	4
41	★OIL SEAL	25227-911		1	93	PIPE PLUG	P-08	11990	2
42	PIPE PLUG	P-02	11990	1	94	★SPOOL FLANGE GASKET	2751-G	18000	1
43	★SLINGER RING	31134-047		1	95	HEX HEAD CAPSCREW	B-1415	15991	12
44	HEX HEAD CAPSCREW	B-1210	15991	12	96	LOCKWASHER	J-14	15991	12
45	LOCKWASHER	J-12	15991	12	97	HEX NUT	D-14	15991	12
46	VOLUTE DRAIN PLUG	P-24	11990	1	98	GROOVED PIN	21142-268		1
47	★SHAFT SLEEVE	31163-001		1	99	SPRING CENTERING WASHER	31512-025		1
48	ACCESSORY PIPE PLUG	P-16	11990	1	NOT SHOWN:				
49	★WEAR PLATE	38691-851		2		STRAINER	4990-A		1
50	PEDESTAL FOOT	38151-002		1		ROTATION DECAL	2613-CU	00000	1
51	HEX HEAD CAPSCREW	B-1209	15991	8		NAME PLATE	2613-D	13990	1
52	LOCKWASHER	J-12	15991	12		DRIVE SCREW	BM#04-03	15990	4

★ Indicates parts recommended for stock

Note: This parts list applies to pumps from serial no. 706754.

Above Serial Numbers Do Not Apply To Pumps Made In Canada.

## PUMP AND SEAL DISASSEMBLY AND REASSEMBLY

This pump requires little service due to its rugged, minimum-maintenance design. If it becomes necessary to inspect and/or replace the wearing parts, however, follow these instructions, which are keyed to the sectional view (see figure 1) and the accompanying parts list.

### Pump Disassembly

#### WARNING

Before attempting to open or service the pump:

1. Familiarize yourself with this manual.
2. Disconnect the power source to ensure that the pump will remain inoperative.
3. Allow the pump to cool if overheated.
4. Vent the pump slowly and cautiously.
5. Close the suction and discharge valves.
6. Check the temperature before opening any covers, plates, or plugs.
7. Drain the pump.

Close all connecting valves, and remove the volute housing drain plug (46) to drain the pump. Clean and reinstall the plug after the pump has been drained.

For access to the impeller (2), disengage the hex head capscrews (44) securing the volute casing (1) and intermediate (9). The rotating assembly, intermediate, and pedestal body (35) will separate from the volute casing as a unit.

Block the impeller, and disengage the socket head capscrew (77). Remove the impeller washer (76), and slide the impeller off the shaft (22), retaining the impeller key (78). Use caution when sliding the impeller off the shaft; tension on the seal spring will be released as the impeller is removed.

### Seal Disassembly

Remove the lower seal cavity plug (11) to drain the seal cavity. Clean and reinstall the plug.

Remove the spring centering washer (99) and the seal spring. Using a stiff wire with a hooked end if necessary, remove the remainder of the seal components and the shaft sleeve (47).

### Bearing Disassembly

Remove the pedestal body drain plug (34) to drain the pedestal body. Clean and reinstall the plug.

Disengage the hex head capscrews (36) securing the pedestal body to the intermediate, and remove the pedestal body and the impeller shaft. Remove the slinger ring (43).

Disengage the hex head capscrews (17) securing the bearing housing (31) to the pedestal body, and remove the bearing housing, bearing housing shims (32), impeller shaft, and bearings from the pedestal body. Tie the bearing housing shims. Disengage the hex head capscrews (19) securing the bearing cap (25) to the bearing housing, and remove the bearing cap, oil seal (15), and bearing cap gasket set (26).

Remove the inboard bearing (12) from the shaft, and remove the bearing housing. Disengage the tabs of the lockwasher (24) from the locknut (23), and disengage the locknut from the shaft. Remove the outboard bearings (16).

Clean the seal cavity, the impeller shaft, and the I.D. of the bearings with a soft cloth soaked in cleaning solvent.

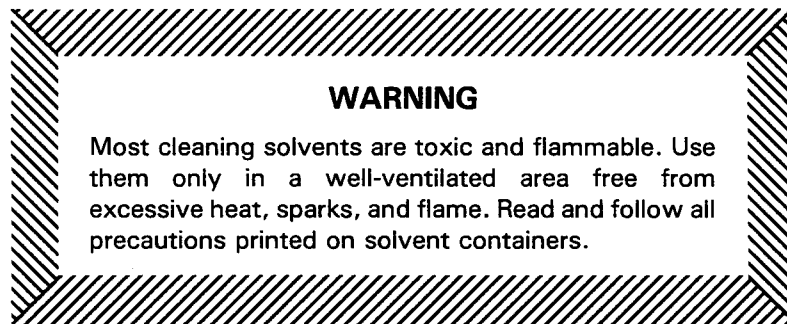

### Bearing Reassembly

If a Thermo Bearing Mounter is available, use it to heat the inner races of the outboard bearings to 300°F for a minimum of 6 minutes. If a Thermo Bearing Mounter is not available, use a heat lamp or other suitable device to heat the inner races.

Mount the heated outboard bearings on the impeller shaft, making certain that they are installed with the loading opening sides facing each other and the ball contact angles converging toward the center (see figure 2).

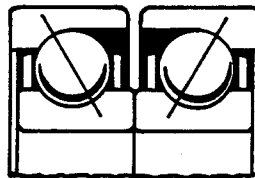

**Figure 2. Correct Bearing Mounting**

Also make certain that the inner bearing is seated squarely against the shaft shoulder, and that the inner races of the bearings are totally bottomed against each other.

While the bearings are still hot, promptly install the bearing lockwasher and locknut. Tighten the locknut, and bend the tabs of the lockwasher over the locknut.

Make certain that there are no burrs or dirt on the interior surfaces of the bearing housing, and use a heat lamp or other suitable device to heat the bearing housing to 300°F for a minimum of 10 minutes. Slip the cooled shaft and mounted outboard bearings into the heated bearing housing, making certain that the bearings are squarely seated against the step of the housing.



Inspect the bearing cap oil seal and replace it if worn. Install the oil seal in the bearing cap with the lip of the seal toward the bearings as shown in figure 1.

Position the bearing cap on the bearing housing, engage the hex head capscrews, and secure the bearing cap to the bearing housing. Use a feeler gauge to measure the gap between the outboard surface of the bearing housing and the inboard surface of the bearing cap. (This gap can also be measured by positioning pieces of solder wire between the two surfaces before the capscrews are fully tightened; tighten the screws, back them off, and measure the thickness of the crushed solder wire.) Add .002 inch to the measurement taken, remove the bearing cap, and add a corresponding thickness of bearing cap gaskets between the bearing cap and the bearing housing. Since the bearing cap must clamp the outer ring of the outboard bearing to preload the bearings, measurement of the gap and installation of the correct thickness of bearing cap gaskets is critical.

Install the bearing cap gaskets, lockwashers (20), and hex head capscrews, and secure the bearing cap to the bearing housing. Check the shaft for end play; if end play exists, remove bearing cap gaskets until the end play is corrected.

Use a Thermo Bearing Mounter, heat lamp, or other suitable device to heat the inner race of the inboard bearing to 300°F for a minimum of 6 minutes. Mount the bearing on the shaft, making certain that it seats squarely against the shaft shoulder.

Replace the bearing housing O-ring. Reinstall the bearing housing shims, and position the shaft, assembled bearings, and bearing housing in the pedestal body. Reinstall the lockwashers and hex head capscrews, and secure the bearing housing to the pedestal body.

Inspect the pedestal body oil seal (14) and replace it if worn. Install the oil seal in the pedestal body with the lip of the seal toward the bearing as shown in figure 1. Install the slinger ring on the shaft.

#### **Seal Reassembly**

The seal is not normally reused because of the high polish on its lapped faces, but if it is necessary to reuse the old seal, wash all metallic parts in cleaning solvent and dry thoroughly.

Inspect the seal components for wear, scoring, grooves, and other damage that might cause leakage. If any components are worn, replace the complete seal; never mix old and new seal parts.

#### **CAUTION**

This seal is not designed for operation at temperatures above 160°F. Do not use at higher operating temperatures.

See figure 3 for the correct order of installation of seal components.

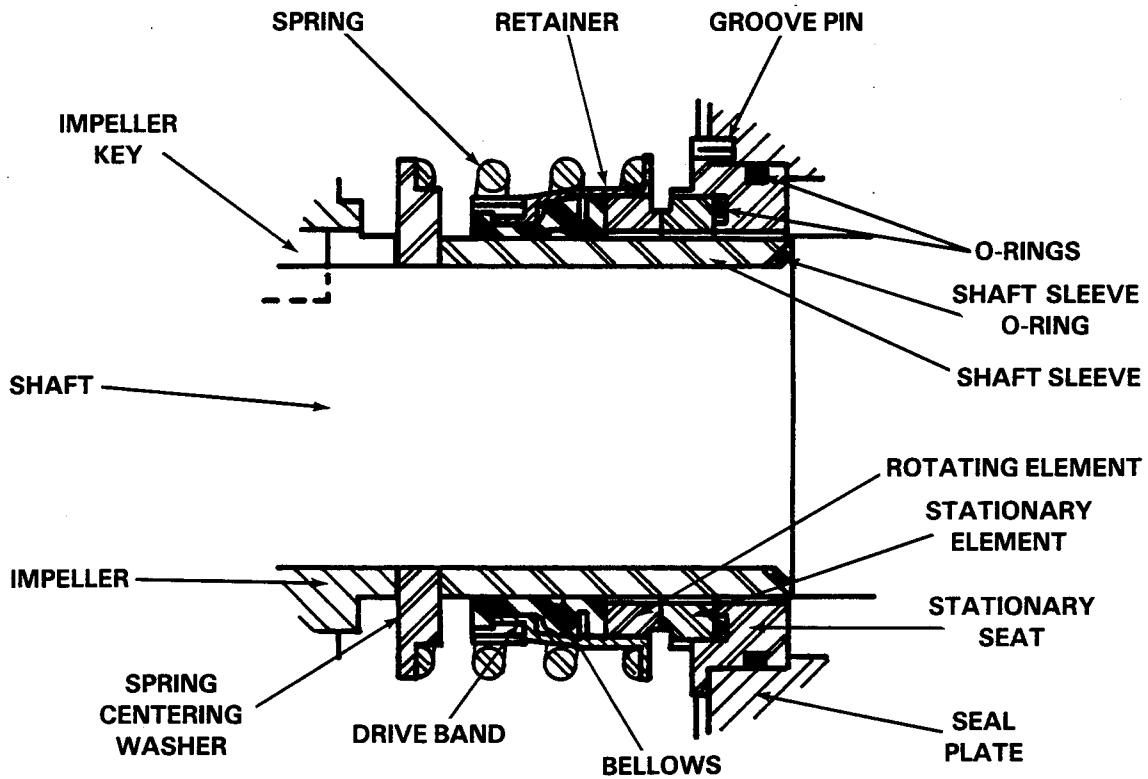

Figure 3. 46512-007 Seal Assembly

Clean and polish the shaft sleeve, or replace it if there are nicks or cuts on the end.

Reinstall the shaft sleeve, and install the replacement seal as a complete unit.

Lubricate the O-rings and bellows with soft grease or oil when installing the seal, and place a drop of light lubricating oil on the lapped faces. Assemble the seal as shown in figure 3.

#### Pump Reassembly

Inspect the impeller, and replace it if cracked or badly worn. Make certain that the seal components are seated squarely on the shaft sleeve, reinstall the impeller key, and slip the impeller on the shaft. Reinstall the impeller washer, block the impeller, and reinstall and tighten the impeller socket head capscrew.

For maximum pump efficiency, there should be a clearance of .015 inch between the impeller and the seal plate. Measure this clearance, and adjust it by adding or removing bearing housing shims.





Inspect the adjustable wear plate (49), and replace it if worn or grooved. To remove the wear plate, disengage the hex nuts (57) securing it to the suction head (58). If the wear plate is removed or replaced, replace the O-rings (5 and 90) before securing it to the suction head.

Reassemble the pedestal body and the intermediate. Replace the seal plate O-ring (6), and reassemble the intermediate and the volute casing.

For maximum pump efficiency, there should be a clearance of .015 inch between the impeller and the wear plate. To arrive at this clearance, loosen the hex nuts securing the wear plate to the suction head. Back off the jam nuts (92) to the heads of the adjusting screws (91), and tighten the adjusting screws evenly no more than a half turn at a time while rotating the impeller shaft by hand. When the wear plate makes contact with the impeller at all points, back off each of the adjusting screws a half turn, and tighten the jam nuts until they are snug against the suction head. Tighten the hex nuts securing the wear plate to the suction head. The impeller clearance should now be correct.

Add clean liquid to the volute, make certain that all piping is securely tightened, and open all connecting valves before starting the pump.

## **LUBRICATION**

### **Seal Assembly**

Fill the seal cavity through the oil cup (28) with a good grade of SAE 30 non-detergent motor oil.

### **Bearings**

Remove the pedestal body air vent (13), and fill the pedestal body through the oil cup (30) with a good grade of SAE 30 non-detergent motor oil. Do not fill beyond the level of the oil cup pipe nipple (29). Clean and reinstall the air vent.

Check the oil level regularly. In normal service, drain and fill the pedestal body with clean oil yearly.

**For U.S. and International Warranty Information,  
Please Visit [www.grpumps.com/warranty](http://www.grpumps.com/warranty)  
or call:  
U.S.: 419-755-1280  
International: +1-419-755-1352**

**For Canadian Warranty Information,  
Please Visit [www.grcanada.com/warranty](http://www.grcanada.com/warranty)  
or call:  
519-631-2870**