



**PRIME-AIRE® SERIES**  
**PA6C Pumps**

**MANUAL**  
**PART 3 of 3**

**MAINTENANCE**  
**AND**  
**REPAIR**  
**WITH**  
**TROUBLESHOOTING**

**THE GORMAN-RUPP COMPANY • MANSFIELD, OHIO**

**GORMAN-RUPP OF CANADA LIMITED • ST. THOMAS, ONTARIO, CANADA**

Printed in U.S.A.

©Copyright by the Gorman-Rupp Company

Register your new  
Gorman-Rupp pump online at  
**[www.gormanrupp.com/register](http://www.gormanrupp.com/register)**.

Valid serial number and e-mail address required.



**The engine exhaust from this product contains chemicals known to the State of California to cause cancer, birth defects or other reproductive harm.**

**RECORD YOUR PUMP MODEL AND SERIAL NUMBER**

Please record your pump model and serial number in the spaces provided below. Your Gorman-Rupp distributor needs this information when you require parts or service.

Pump Model: \_\_\_\_\_

Serial Number: \_\_\_\_\_

## INTRODUCTION

**Thank You** for purchasing a Gorman-Rupp Prime-Aire® Series priming-assisted pump. **Read this manual** carefully to learn how to safely maintain and service your pump. Failure to do so could result in personal injury or damage to the pump.

A set of three manuals accompanies your pump. The Installation/Operation Manual contains essential information on installing and operating the pump, and on making electrical connections. The Parts List Manual provides performance curve(s), a pump model cross-section drawing, and parts list for your pump.

This Maintenance and Repair Manual provides troubleshooting instructions required to properly diagnose operational problems. Maintenance instructions within this manual are limited to the pump hydraulic and drive components only. For maintenance and repair of the engine or air compressor, consult the separate literature provided by the manufacturers.

This pump is a PA Series®, priming-assisted centrifugal model. The unit is designed for handling non-volatile, non-flammable liquids containing specified entrained solids. For specific service, contact your Gorman-Rupp distributor or the Gorman-Rupp Company.

As described on the following page, this manual will alert personnel to known procedures which require special attention, to those which could damage equipment, and to those which could be dangerous to personnel. However, this manual cannot possibly anticipate and provide detailed precautions for every situation that might occur during maintenance of the unit. Therefore, it is the responsibility of the owner/maintenance personnel to ensure that **only** safe, established maintenance procedures are used, and that any procedures not addressed in this manual are performed **only** after establishing that neither personal safety nor pump integrity are compromised by such practices.

If there are any questions regarding the pump which are not covered in this manual or in other literature accompanying the unit, please contact your Gorman-Rupp distributor or the Gorman-Rupp Company:

**The Gorman-Rupp Company**  
**P.O. Box 1217**  
**Mansfield, Ohio 44901 – 1217**  
 or  
**Gorman-Rupp of Canada Limited**  
**70 Burwell Road**  
**St. Thomas, Ontario N5P 3R7**

## CONTENTS

### SAFETY – SECTION A

### TROUBLESHOOTING – SECTION B

### PUMP MAINTENANCE AND REPAIR – SECTION C

DRAWINGS AND IDENTIFICATION LISTS .....	PAGES C – 2 THRU C – 11
PUMP AND SEAL DISASSEMBLY AND REASSEMBLY .....	PAGE C – 12
Priming Chamber Removal And Disassembly .....	PAGE C – 13
Discharge Check Valve Removal and Disassembly .....	PAGE C – 13
Back Cover Plate and Wear Ring Removal .....	PAGE C – 13
Separating Bearing Housing And Drive Assembly From Engine .....	PAGE C – 14
Draining Oil From Seal Cavity .....	PAGE C – 14
Loosening Impeller .....	PAGE C – 14
Pump Casing Removal .....	PAGE C – 15
Impeller Removal .....	PAGE C – 15
Seal Removal .....	PAGE C – 15
Shaft and Bearing Removal and Disassembly .....	PAGE C – 15
Shaft and Bearing Reassembly and Installation .....	PAGE C – 16
Securing Bearing Housing And Drive Assembly To Engine .....	PAGE C – 17

**CONTENTS (Cont'd)**

Seal Reassembly and Installation ..... PAGE C – 18  
 Impeller Installation And Adjustment ..... PAGE C – 19  
 Pump Casing Installation ..... PAGE C – 20  
 Back Cover Plate And Wear Ring Installation ..... PAGE C – 20  
 Priming Chamber Assembly And Installation ..... PAGE C – 20  
 Discharge Check Valve Assembly And Installation ..... PAGE C – 21  
 LUBRICATION ..... PAGE C – 21  
 Seal Assembly ..... PAGE C – 21  
 Bearings ..... PAGE C – 21  
 Power Unit ..... PAGE C – 22

**RECORDING MODEL AND SERIAL NUMBERS**

Please record the pump model and serial number in the spaces provided below. Your Gorman-Rupp distributor needs this information when you require parts or service.

Pump Model: \_\_\_\_\_

Serial Number: \_\_\_\_\_

**WARRANTY INFORMATION**

The warranty provided with your pump is part of Gorman-Rupp's support program for customers who operate and maintain their equipment as described in this and the other accompanying literature. Please note that should the equipment be abused or modified to change its performance beyond the original factory specifications, the warranty will become void and any claim will be denied.

The following are used to alert personnel to procedures which require special attention, to those which could damage equipment, and to those which could be dangerous to personnel:



**Immediate hazards which WILL result in severe personal injury or death. These instructions describe the procedure required and the injury which will result from failure to follow the procedure.**



Hazards or unsafe practices which COULD result in minor personal injury or product or property damage. These instructions describe the requirements and the possible damage which could result from failure to follow the procedure.



**Hazards or unsafe practices which COULD result in severe personal injury or death. These instructions describe the procedure required and the injury which could result from failure to follow the procedure.**

**NOTE**

*Instructions to aid in installation, operation, and maintenance or which clarify a procedure.*

## SAFETY – SECTION A

The following information applies throughout this manual to Gorman-Rupp Prime Aire® Series pumps.

This manual will alert personnel to known procedures which require special attention, to those which could damage equipment, and to those which could be dangerous to personnel. However, this manual cannot possibly anticipate and provide detailed instructions and precautions for every situation that might occur during maintenance of the unit. Therefore, it is the responsibility of the owner/maintenance personnel to ensure that only safe, established maintenance procedures are used, and that any procedures not addressed in this manual are performed only after establishing that neither personal safety nor pump integrity are compromised by such practices.



Before attempting to install, operate, or service this pump, familiarize yourself with this manual, and with all other literature shipped with the pump. Unfamiliarity with all aspects of pump operation covered in this manual could lead to destruction of equipment, injury, or death to personnel.



Before attempting to open or service the pump:

1. Familiarize yourself with this manual.
2. Shut down the engine, disconnect the positive battery cable and take

precautions to ensure that the pump will remain inoperative.

3. Allow the pump to completely cool if overheated.
4. Check the temperature before opening any covers, plates, or plugs.
5. Close the suction and discharge valves.
6. Vent the pump slowly and cautiously.
7. Drain the pump.



This pump is may be used to handle materials which could cause illness through direct exposure or emitted fumes. Wear adequate protective clothing when working on the pump or piping.



Use lifting and moving equipment in good repair and with adequate capacity to prevent injuries to personnel or damage to equipment. Attach lifting equipment to the lifting device fitted to the pump. If chains or cable are wrapped around the pump to lift it, make certain that they are positioned so as not to damage the pump, and so that the load will be balanced. The bail is intended for use in lifting the pump assembly only. Suction and discharge hoses and piping must be removed from the pump before lifting.



After the pump has been installed, make

certain that the pump and all piping or hose connections are tight, properly supported and secure before operation.



Do not remove plates, covers, gauges, pipe plugs, or fittings from an overheated pump. Vapor pressure within the pump can cause parts being disengaged to be ejected with great force. Allow the pump to cool before servicing.



Overheated pumps can cause severe burns and injuries, and produce explosive fumes. If overheating of the pump occurs:

1. Stop the pump immediately.
2. Ventilate the area.
3. Allow the pump to completely cool.
4. Check the temperature and make sure it is cool before opening any covers, plates, gauges, or plugs.
5. Vent the pump slowly and cautiously.
6. Refer to instructions in the manuals accompanying the pump before restarting the pump.



Do not operate the pump without the guards in place over the rotating parts. Exposed rotating parts can catch clothing, fingers, or tools, causing severe injury to personnel.

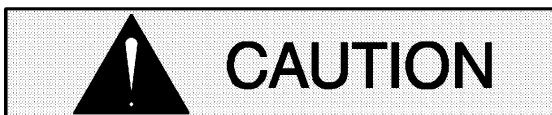

Use **only** replacement parts provided or

approved by Gorman-Rupp. Use of non-authorized parts may result in damage to the equipment and/or injury to personnel and **will** invalidate the warranty.



Make sure the pump is level. Lower jack stands and chock the wheels, if so equipped. Use caution when positioning the skid-mounted unit to prevent damage to the fuel tank.



Do not operate an internal combustion engine in an explosive atmosphere. When operating an internal combustion engine in an enclosed area, make sure exhaust fumes are piped to the outside. These fumes contain carbon monoxide, a deadly gas that is colorless, tasteless and odorless.



Fuel used by internal combustion engines presents an extreme explosion and fire hazard. Make certain that all fuel lines are securely connected and free of leaks. Never refuel a hot or running engine. Avoid overfilling the fuel tank. Always use the correct type of fuel.



Never tamper with the governor to gain more power. The governor establishes safe operating limits that should not be exceeded. Refer to the pump Performance Curve for the maximum continuous operating speed.

**TROUBLESHOOTING – SECTION B**

Review all SAFETY information in Section A.



**Before attempting to open or service the pump:**

- 1. Familiarize yourself with this manual.**
- 2. Shut down the engine and disconnect the positive battery cable and take precautions to ensure that the pump will remain inoperative.**
- 3. Allow the pump to completely cool if overheated.**
- 4. Check the temperature and make sure pump is cool before opening any covers, plates, or plugs.**
- 5. Close the suction and discharge valves.**
- 6. Vent the pump slowly and cautiously.**
- 7. Drain the pump.**

TROUBLE	POSSIBLE CAUSE	PROBABLE REMEDY
<p>PUMP FAILS TO PRIME</p>	<p>Discharge check valve contaminated, damaged, or unable to seat.</p> <p>Air compressor head 180° out.</p> <p>Air leak in suction line.</p> <p>Lining of suction hose collapsed.</p> <p>Leaking or worn seal or pump gasket.</p> <p>Eductor safety valve leaking.</p> <p>Suction lift or discharge head too high.</p> <p>Pump speed too slow.</p> <p>Eductor clogged.</p> <p>Air compressor damaged or belts broken.</p> <p>Strainer clogged.</p>	<p>Clean or replace check valve.</p> <p>Consult factory.</p> <p>Correct leak.</p> <p>Replace suction hose.</p> <p>Check pump vacuum. Replace leaking or worn seal or gasket.</p> <p>Check and replace safety valve.</p> <p>Check piping installation and install bypass line if needed. See <b>INSTALLATION</b>.</p> <p>Check driver output; consult driver operation manual.</p> <p>Check and clean eductor.</p> <p>Check and repair/replace.</p> <p>Check strainer and clean if necessary.</p>

TROUBLE	POSSIBLE CAUSE	PROBABLE REMEDY
PUMP STOPS OR FAILS TO DELIVER RATED FLOW OR PRESSURE	Eductor clogged. Air leak in suction line. Lining of suction hose collapsed. Leaking or worn seal or pump gasket.  Strainer clogged.  Discharge check valve clogged. Suction intake not submerged at proper level or sump too small. Impeller or other wearing parts worn or damaged.  Impeller clogged. Discharge head too high. Suction lift too high.  Pump speed too slow.  Belt or flexible coupling broken.	Check and clean eductor. Correct leak. Replace suction hose. Check pump vacuum. Replace leaking or worn seal or gasket. Check strainer and clean if necessary. Check and clean check valve. Check installation and correct submergence as needed. Replace worn or damaged parts. Check that impeller is properly centered and rotates freely. Free impeller of debris. Install bypass line. Measure lift w/vacuum gauge. Reduce lift and/or friction losses in suction line. Check driver output; consult driver operation manual. Check and replace as necessary.
PUMP REQUIRES TOO MUCH POWER	Pump speed too high. Extreme ambient temperature. Discharge head too low. Fuel filter clogged (engine driven units). Liquid solution too thick. Fuel contaminated (engine driven units). Pump or jack shaft bearing(s) frozen.	Check driver output. Reduce pump output. Adjust discharge valve. Check & replace often in extreme operating conditions. Dilute if possible. Check and replace as required.  Disassemble, check and replace bearing(s) as required..
PUMP CLOGS FREQUENTLY	Discharge flow too slow.  Suction check valve or foot valve clogged or binding.  Liquid solution too thick.	Open discharge valve fully to increase flow rate, and run engine at maximum governed speed. Clean valve.  Dilute if possible.

TROUBLE	POSSIBLE CAUSE	PROBABLE REMEDY
EXCESSIVE NOISE	Cavitation in pump.  Pumping entrained air.  Pump or drive not securely mounted. Impeller clogged or damaged.	Reduce suction lift and/or friction losses in suction line. Record vacuum and pressure gauge readings and consult local representative or factory.  Locate and eliminate source of air bubble.  Secure mounting hardware.  Clean out debris; replace damaged parts.
BEARINGS RUN TOO HOT	Bearing temperature is high, but within limits.  Low or incorrect lubricant.  Suction and discharge lines not properly supported.  Drive misaligned.  Excessive tension on drive belt.	Check bearing temperature regularly to monitor any increase.  Check for proper type and level of lubricant.  Check piping installation for proper support.  Align drive properly.  Check belt tension. Adjust as required.

**PREVENTIVE MAINTENANCE**

Since pump applications are seldom identical, and pump wear is directly affected by such things as the abrasive qualities, pressure and temperature of the liquid being pumped, this section is intended only to provide general recommendations and practices for preventive maintenance. Regardless of the application however, following a routine preventive maintenance schedule will help assure trouble-free performance and long life from your Gorman-Rupp pump. For specific questions concerning your application, contact your Gorman-Rupp distributor or the Gorman-Rupp Company.

Record keeping is an essential component of a good preventive maintenance program. Changes in suction and discharge gauge readings (if so

equipped) between regularly scheduled inspections can indicate problems that can be corrected before system damage or catastrophic failure occurs. The appearance of wearing parts should also be documented at each inspection for comparison as well. Also, if records indicate that a certain part (such as the seal) fails at approximately the same duty cycle, the part can be checked and replaced before failure occurs, reducing unscheduled down time.

For new applications, a first inspection of wearing parts at 250 hours will give insight into the wear rate for your particular application. Subsequent inspections should be performed at the intervals shown on the chart below. Critical applications should be inspected more frequently.

<b>Preventive Maintenance Schedule</b>					
<b>Item</b>	<b>Service Interval*</b>				
	<b>Daily</b>	<b>Weekly</b>	<b>Monthly</b>	<b>Semi-Annually</b>	<b>Annually</b>
General Condition (Temperature, Unusual Noises or Vibrations, Cracks, Leaks, Loose Hardware, Etc.)	I				
Pump Performance (Gauges, Speed, Flow)	I				
Bearing Lubrication		I			R
Seal Lubrication (And Packing Adjustment, If So Equipped)		I			R
V-Belts (If So Equipped)			I		
Air Release Valve Plunger Rod (If So Equipped)			I	C	
Front Impeller Clearance (Wear Plate)				I	
Rear Impeller Clearance (Seal Plate)				I	
Check Valve					I
Pressure Relief Valve (If So Equipped)					C
Pump and Driver Alignment					I
Shaft Deflection					I
Bearings					I
Bearing Housing					I
Piping					I
Driver Lubrication – See Mfgr’s Literature					I
<p>Legend:                      I = Inspect, Clean, Adjust, Repair or Replace as Necessary                      C = Clean                      R = Replace</p> <p>* Service interval based on an intermittent duty cycle equal to approximately 4000 hours annually. Adjust schedule as required for lower or higher duty cycles or extreme operating conditions.</p>					

## PUMP MAINTENANCE AND REPAIR – SECTION C

Review all **SAFETY** information in Section A.

Follow the instructions on all tags, label and decals attached to the pump.



**Before attempting to install, operate, or service this pump, familiarize yourself with this manual, and with all other literature shipped with the pump. Unfamiliarity with all aspects of operation or maintenance could lead to destruction of equipment, injury or death to personnel.**



**Use lifting and moving equipment in good repair and with adequate capacity to prevent injuries to personnel or damage to equipment. If slings or chains are used to move the pump or components, make sure that the load is balanced; otherwise serious personal injury or death could result. The bail is intended for use in lifting the pump assembly only. Suction and discharge hoses and piping must be removed from the pump before lifting.**

The maintenance and repair instructions in this manual are keyed to the sectional views and the corresponding parts identification lists on the following pages. Refer to the separate Parts List Manual for replacement parts.

This Maintenance and Repair Manual provides troubleshooting instructions required to properly diagnose operational problems. Maintenance instructions within this manual are limited to the

pump hydraulic, priming and drive components only. The pump assembly may be close-coupled to either a factory-supplied or customer-supplied engine. Maintenance of engines and factory-supplied air compressors are detailed in separate literature provided by the manufacturer(s).

Check **TROUBLESHOOTING**, Section B to determine causes and remedies of pump problems. Disassemble the pump only as far as required.

As described in the **SAFETY** Section, this manual will alert personnel to known procedures which require special attention, to those which could damage equipment, and to those which could be dangerous to personnel. However, this manual cannot possibly anticipate and provide detailed precautions for every situation that might occur during maintenance of the unit. Therefore, it is the responsibility of the owner/maintenance personnel to ensure that **only** safe, established shop procedures are used, and that any procedures not addressed in this manual are performed **only** after establishing that neither personal safety nor pump integrity are compromised by such practices.

Select a suitable location, preferably indoors, to perform required maintenance. All work must be performed by qualified personnel.

### Lifting

Use lifting equipment with a capacity of **at least five times the weight of the component being lifted**. When lifting the complete unit, the lifting equipment must also be capable of lifting the weight of any options or customer-installed accessories. Suction and discharge hoses or piping **must** be removed before attempting to lift the pump.

For the approximate weight of your pump, refer to the pump specification data sheet or contact your Gorman-Rupp distributor or the Gorman-Rupp Company.

SECTION DRAWING

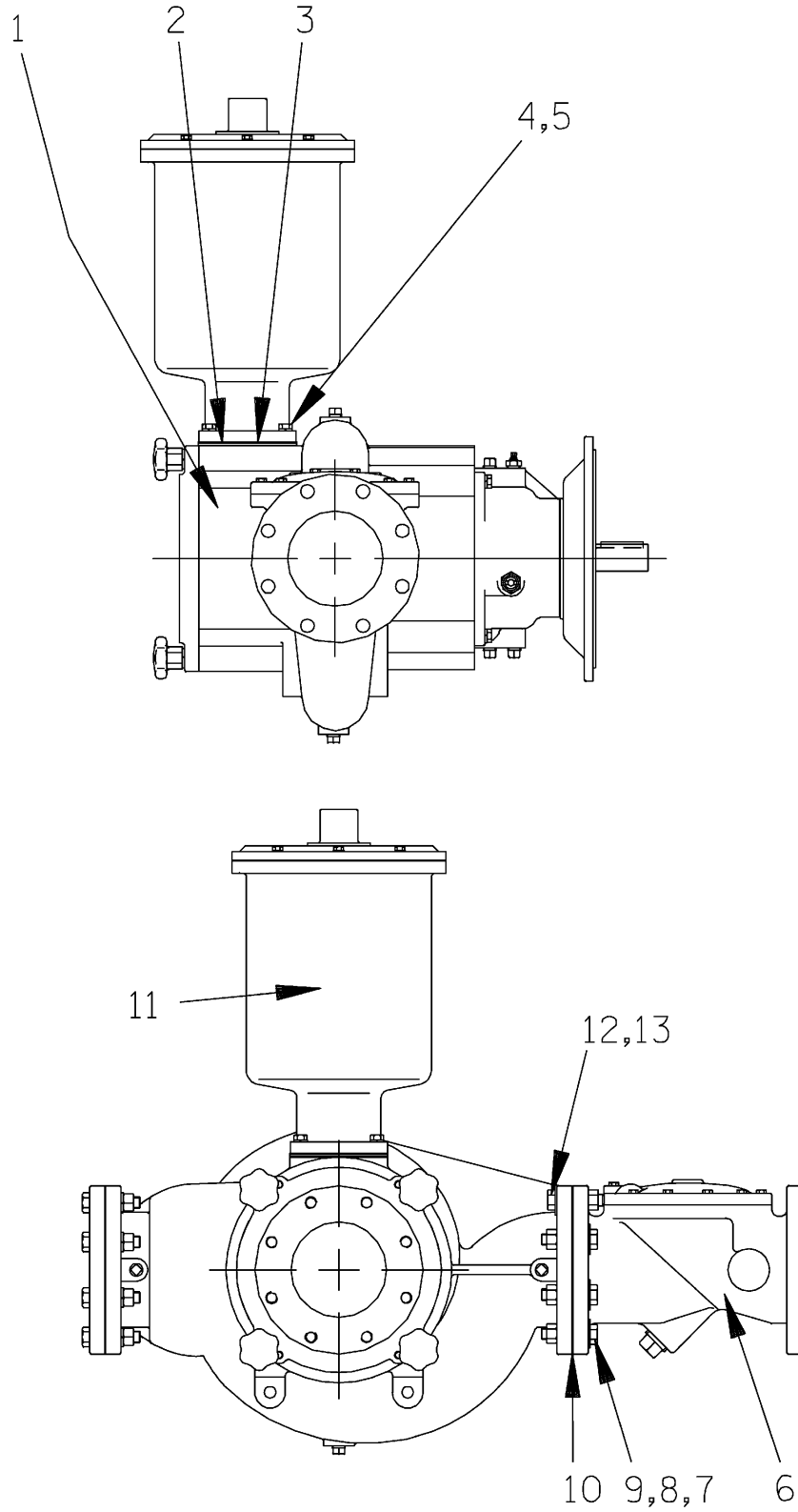

Figure C-1. PA6C60-(SAE 4/10) Pump Model Assembly

**PA6C60 – (SAE4/10) Pump Model Assembly  
Part Identification List**

Refer to the separate Parts List Manual for serviceable parts, part numbers and quantities.

ITEM NO.	PART NAME
1	PUMP END ASSEMBLY
2	BAFFLE PLATE
3	GASKET
4	HEX HEAD CAPSCREW
5	LOCKWASHER
6	CHECK VALVE ASSEMBLY
7	HEX HEAD CAPSCREW
8	LOCKWASHER
9	HEX NUT
10	GASKET
11	PRIMING CHAMBER ASSEMBLY
12	HEX HEAD CAPSCREW
13	HEX NUT

NOTE: Maintenance instructions in this manual are limited to the pump hydraulic, priming and drive components only. Maintenance of engines and factory-supplied air compressors are detailed in separate literature provided by the manufacturer(s).

SECTION DRAWING

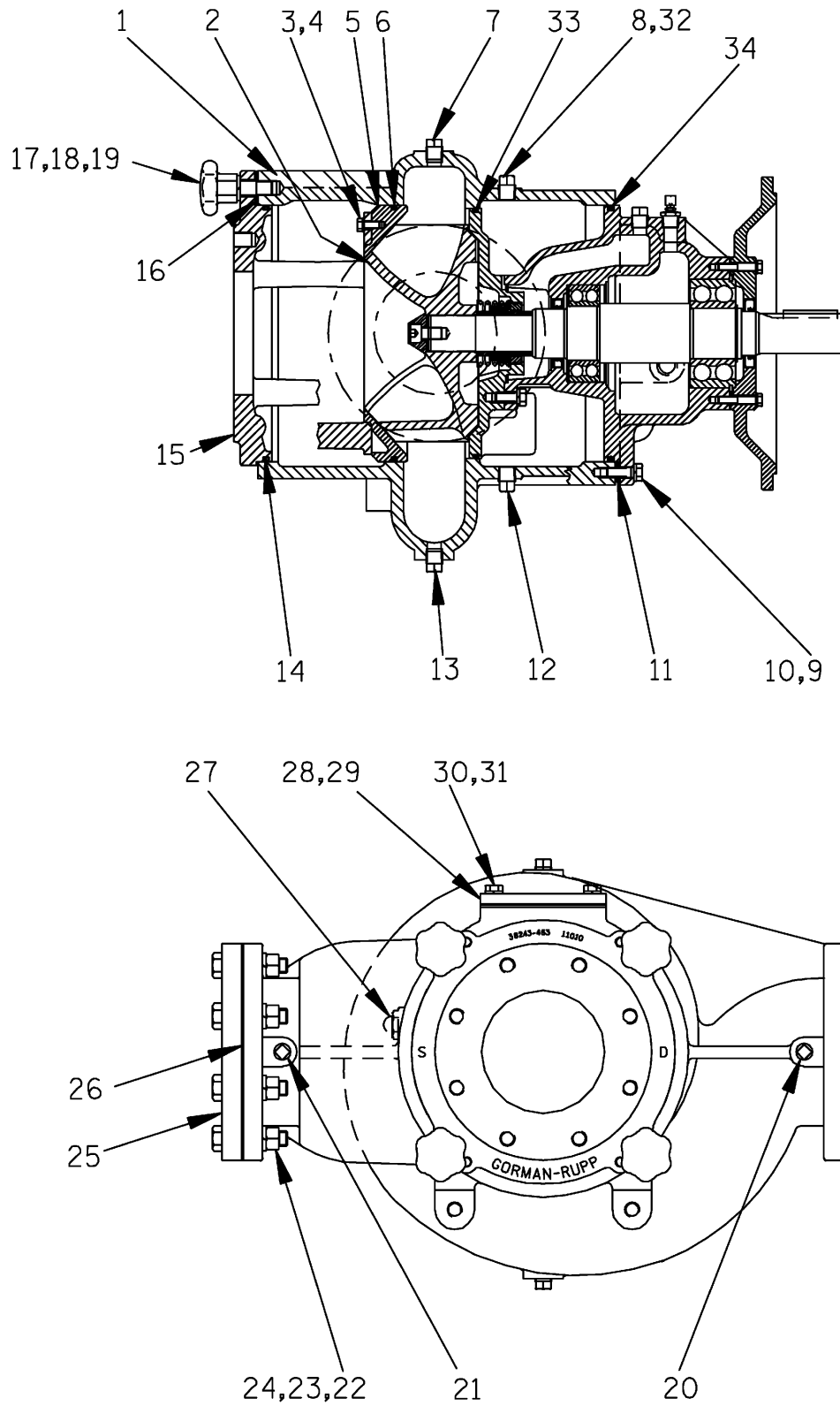

Figure C-2. 66F60-(SAE 4/10) Pump End Assembly

**66F60 – (SAE 4/10) Pump End Assembly  
Part Identification List**

Refer to the separate Parts List Manual for serviceable parts, part numbers and quantities.

ITEM NO.	PART NAME
1	PUMP CASING
2	REPAIR ROTATING ASSEMBLY
3	HEX HEAD CAPSCREW
4	LOCKWASHER
5	WEAR RING
6	WEAR RING O-RING
7	PIPE PLUG
8	VENTED PLUG
9	HEX HEAD CAPSCREW
10	LOCKWASHER
11	ADJUSTING SHIM SET
12	PIPE PLUG
13	CASING DRAIN PLUG
14	BACK COVER PLATE O-RING
15	BACK COVER PLATE
16	ADJUSTING SHIM SET
17	STUD
18	LOCKWASHER
19	HAND KNOB
20	PIPE PLUG
21	PIPE PLUG
22	HEX HEAD CAPSCREW
23	LOCKWASHER
24	HEX NUT
25	BLIND FLANGE ASSEMBLY
26	FLANGE GASKET
27	SIGHT GAUGE
28	COVER PLATE
29	COVER PLATE GASKET
30	HEX HEAD CAPSCREW
31	LOCKWASHER
32	SHIPPING PLUG
33	SEAL PLATE O-RING
34	BEARING HOUSING O-RING

SECTION DRAWING

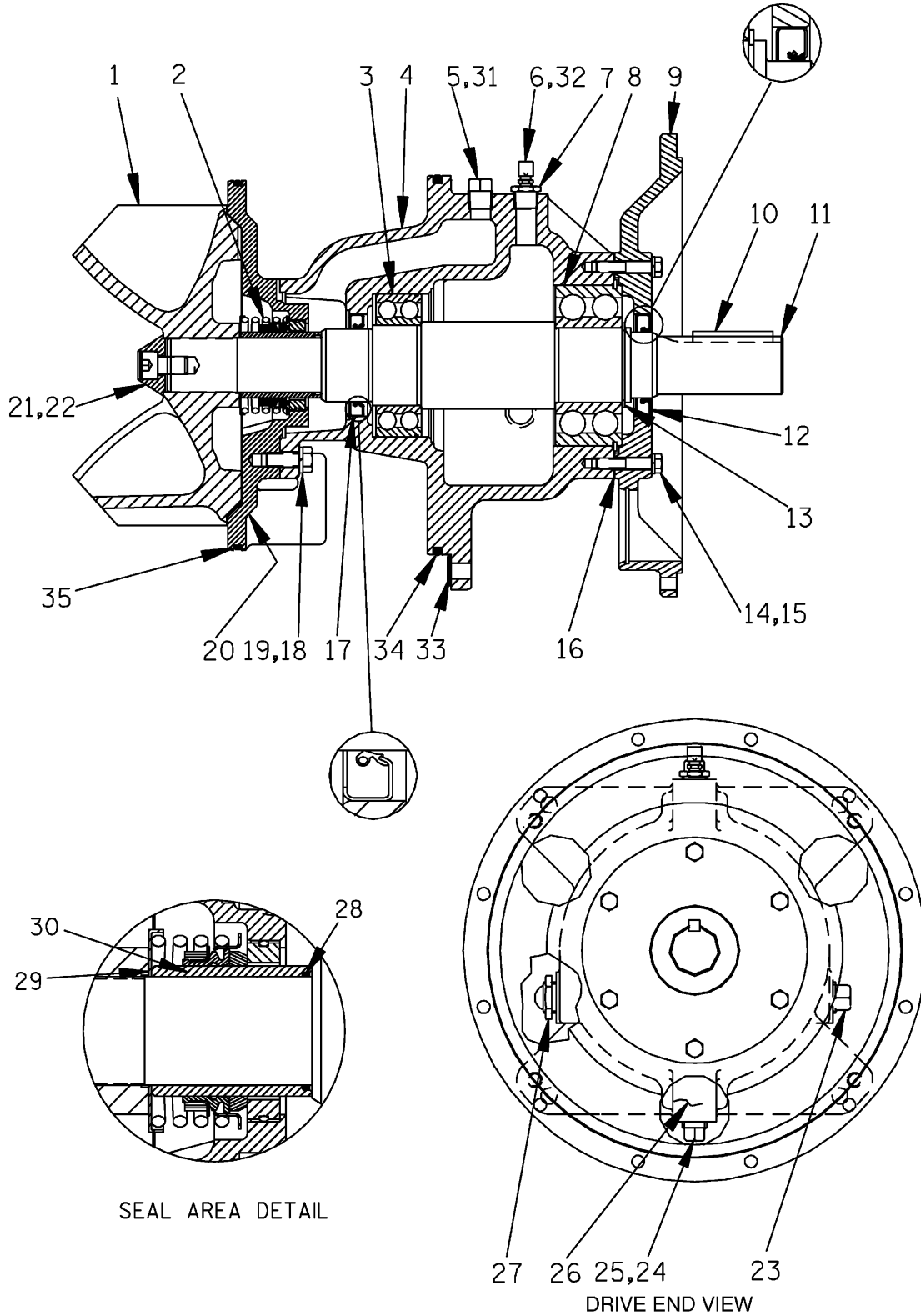

Figure C-3. 44163-253 Repair Rotating Assembly

### 44163-253 Repair Rotating Assembly Part Identification List

Refer to the separate Parts List Manual for serviceable parts, part numbers and quantities.

ITEM NO.	PART NAME
1	IMPELLER
2	SEAL ASSEMBLY
3	INBOARD BALL BEARING
4	BEARING HOUSING
5	VENTED PLUG
6	AIR VENT
7	RED PIPE BUSHING
8	OUTBOARD BALL BEARING
9	DRIVE FLANGE
10	IMPELLER SHAFT KEY
11	IMPELLER SHAFT
12	OIL SEAL
13	SNAP RING
14	HEX HEAD CAPSCREW
15	LOCKWASHER
16	BEARING HOUSING GASKET
17	OIL SEAL
18	HEX HEAD CAPSCREW
19	LOCKWASHER
20	SEAL PLATE
21	SOCKET HEAD CAPSCREW
22	IMPELLER WASHER
23	PIPE PLUG
24	PIPE PLUG
25	BEARING CAVITY DRAIN PLUG
26	SIGHT GAUGE
27	INTERMEDIATE GUARDS
28	SHAFT SLEEVE O-RING
29	IMPELLER ADJ SHIM SET
30	SHAFT SLEEVE
31	SHIP PLUG
32	SHIP PLUG
33	ADJ SHIM SET
34	BRG HOUSING O-RING
35	SEAL PLATE O-RING

SECTION DRAWING

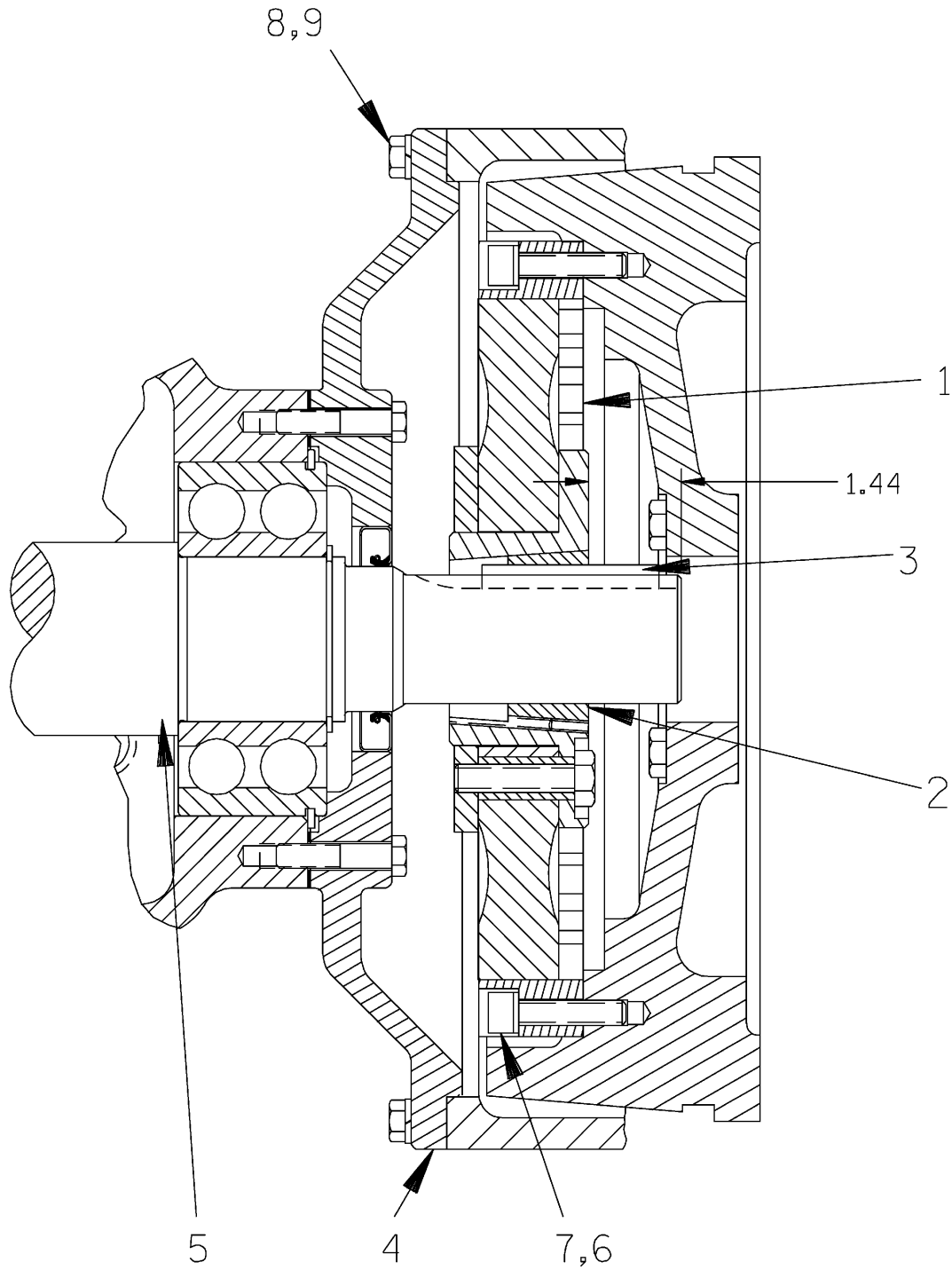

Figure C-4. SAE 4/10 Drive Assembly

**SAE 4/10 Drive Assembly  
Part Identification List**

Refer to the separate Parts List Manual for serviceable parts, part numbers and quantities.

ITEM NO.	PART NAME
1	COUPLING ASSEMBLY
2	BUSHING
3	-KEY
4	DRIVE FLANGE (REF)
5	IMPELLER SHAFT (REF)
6	LOCKWASHER
7	SOC HD CAPSCREW
8	HEX HD CAPSCREW
9	LOCKWASHER

SECTION DRAWING

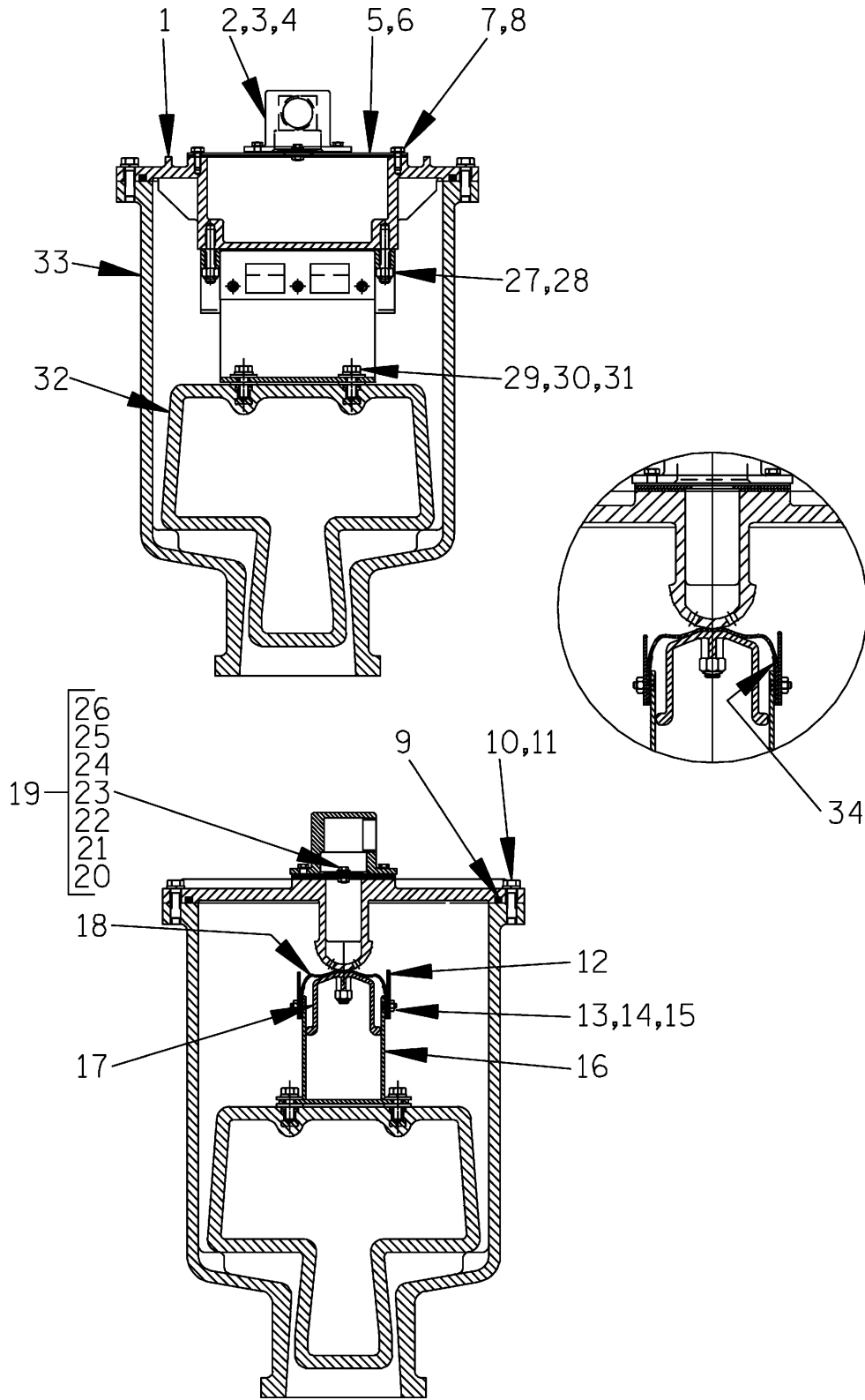

Figure C-5. Peeler Type Priming Valve

**Peeler Type Priming Valve  
Part Identification List**

Refer to the separate Parts List Manual for serviceable parts, part numbers and quantities.

ITEM NO.	PART NAME
1	PRIMING CHAMBER LID
2	PEELER VALVE NECK
3	HEX HEAD CAPSCREW
4	LOCKWASHER
5	VALVE PLATE GASKET
6	VALVE PLATE
7	HEX HEAD CAPSCREW
8	LOCKWASHER
9	LINEAR O-RING
10	HEX HEAD CAPSCREW
11	LOCKWASHER
12	GUIDE PLATE
13	FLAT HEAD CAPSCREW
14	LOCKWASHER
15	HEX NUT
16	VALVE STRAP BRACKET ASSEMBLY
17	CLAMP PLATE
18	VALVE STRAP
19	CHECK VALVE ASSEMBLY
20	-CHECK VALVE
21	-LOCKWASHER
22	-HEX NUT
23	-FLAT WASHER
24	-HEX HEAD CAPSCREW
25	-FLAT WASHER
26	-SEALING WASHER
27	STUD
28	HEX LOCK NUT
29	HEX HEAD CAPSCREW
30	LOCKWASHER
31	FLAT WASHER
32	PRIMING VALVE FLOAT
33	PRIMING CHAMBER
34	VALVE STRAP PROTECTOR

## PUMP AND SEAL DISASSEMBLY AND REASSEMBLY

Review all SAFETY information in Section A.

Follow the instructions on all tags, label and decals attached to the pump.

This pump requires little service due to its rugged, minimum-maintenance design. However, if it becomes necessary to inspect or replace the wearing parts, follow these instructions which are keyed to the Sectional Views (see Figures C-1, C-2, C-3, C-4 and C-5) and the corresponding Parts Identification Lists. Maintenance and repair instructions for the engine and air compressor are covered separately in the specific literature supplied by the manufacturers.

For part numbers and quantities for your specific pump, refer to the separate Parts List manual accompanying the pump.

Many pump service functions may be performed without separating the pump end assembly from the engine. However, the following instructions assume complete disassembly of the pump is required.

Before attempting to service the pump, shut down the engine and take precautions to ensure that it will remain inoperative. Close all valves in the suction and discharge lines and drain the pump casing.

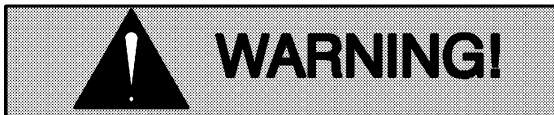

This manual will alert personnel to known procedures which require special attention, to those which could damage equipment, and to those which could be dangerous to personnel. However, this manual cannot possibly anticipate and provide detailed instructions and precautions for every situation that might occur during maintenance of the unit. Therefore, it is the responsibility of the owner/maintenance personnel to ensure that only safe, established maintenance procedures are used, and that

any procedures not addressed in this manual are performed only after establishing that neither personal safety nor pump integrity are compromised by such practices.



Before attempting to open or service the pump:

1. Familiarize yourself with this manual.
2. Shut down the engine, disconnect the positive battery cable and take precautions to ensure that the pump will remain inoperative.
3. Allow the pump to completely cool if overheated.
4. Check the temperature and make sure it is cool before opening any covers, plates, gauges, or plugs.
5. Close the suction and discharge valves.
6. Vent the pump slowly and cautiously.
7. Drain the pump.



This pump is designed to handle material which could cause illness through direct exposure or emitted fumes. Wear adequate protective clothing when working on the pump or piping.

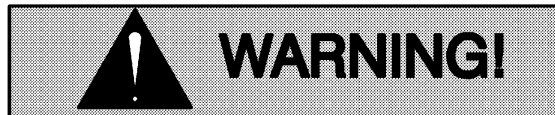

Use lifting and moving equipment in good repair and with adequate capacity to prevent injuries to personnel or damage to equipment. The bail is intended for use in lifting the pump assembly only. Suction and discharge hoses and piping must be removed from the pump before lifting. If chains or cables are used to lift pump components, make

**certain that they are positioned so as not to damage the pump, and so that the load will be balanced.**

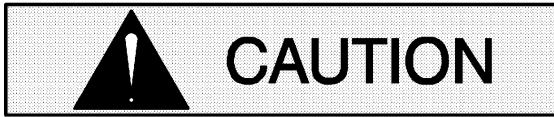

Use **only** replacement parts provided or approved by Gorman-Rupp. Use of non-authorized parts may result in damage to the equipment and/or injury to personnel and **will** invalidate the warranty.

#### **Priming Chamber Removal And Disassembly**

**(Figure C-1)**

Disconnect both the suction piping and the air discharge tubing from the priming chamber assembly (11). Support the priming chamber assembly using a sling and a suitable lifting device. Remove the capscrews (4) and separate the priming chamber assembly and gasket (3) from the pump assembly (1).

**(Figure C-5)**

Remove the hardware (10 and 11) securing the priming chamber lid (1) to the priming chamber (33). Carefully lift the lid and valve components from the priming chamber. If the priming valve float (32) is stuck or the check valve assembly (19) is clogged, they can usually be cleaned without further disassembly.

Inspect the O-ring strip (9) and, if replacement is required, remove the gasket and **all** of the old adhesive.

To remove the float (32), disconnect the hardware (29, 30 and 31).

To replace the valve strap (18), disengage the hardware (13, 14 and 15) and separate the guide plates (12), clamp plate (17) and valve protector (34) from the valve strap. Disengage the hardware (27 and 28) and remove the valve strap.

To remove the check valve assembly (19), disengage the hardware (3 and 4). Remove the peeler valve neck (2) and check valve assembly.

Inspect the check valve components. If the check valve (20) requires replacement, remove the hardware (22, 24 and 25) securing the valve weights (23 and 26) to the check valve.

It is not necessary to remove the valve plate (6) unless the gasket (5) requires replacement. To remove the valve plate, disengage the hardware (7 and 8).

#### **Discharge Check Valve Removal and Disassembly**

**(Figure C-1)**

Support the discharge check valve assembly (6) using a sling and a suitable lifting device. Remove the hardware (7, 8 and 9) securing the discharge check valve assembly and gasket to the pump assembly.

The flapper and gasket are the only serviceable parts of the check valve. If the flapper requires replacement, remove the hardware securing the cover and gasket. Separate the valve cap and remove the flapper.

#### **Back Cover Plate and Wear Ring Removal**

**(Figure C-2)**

Support the pump end assembly using a suitable hoist and sling.

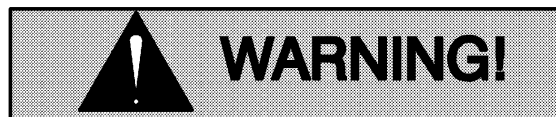

**Use lifting and moving equipment in good repair and with adequate capacity to prevent injuries to personnel or damage to equipment. If slings or chains are used to move the pump or components, make sure that the load is balanced; otherwise serious personal injury or death could result. Suction and discharge hoses and piping must be removed from the pump before lifting.**

Remove the hand knobs and lockwashers (18 and 19). Install four 1/2-13 UNC X 2 inch long capscrews (not supplied) in the tapped holes in the back cover (15). Tighten these jacking screws

evenly in an alternating pattern until the back cover is pressed out of the pump casing (1). Remove the jacking screws from the back cover.

Tie and tag the shims (16) or measure and record their thickness for ease of reassembly. Remove and discard the O-ring (14).

Inspect the wear ring (5) and, if replacement is necessary, remove the hardware (3 and 4) securing it to the back cover plate. Remove and discard the O-ring (6).

### Separating Bearing Housing And Drive Assembly From Engine

#### (Figure C-4)

Further disassembly of the pump requires separating the pump end and drive assembly from the engine. Disconnect the discharge piping from the pump casing.

Remove the hardware (8 and 9) securing the drive flange (4) to the engine bellhousing. Separate the assemblies by pulling the pump end straight away from the engine.

As the assemblies separate, the flexible portion of the coupling assembly (1) will remain on the shaft. To remove the coupling from the shaft, unscrew the two allen head setscrews from the bushing (2). Screw one of the setscrews into the puller hole on the circumference of the bushing. As the coupling and bushing separate, remove the bushing, and slide the coupling off the shaft. Remove the shaft key (3).

It is not necessary to remove the outer ring of the coupling from the engine flywheel unless the coupling must be replaced. To remove the ring, disengage the hardware (6 and 7) securing it to the flywheel.

Move the pump end to a clean, well equipped shop area for further disassembly.

### Draining Oil From Seal Cavity

#### (Figure C-2)

If any further disassembly is to be performed on the pump, the seal cavity oil must be drained to prevent the oil in the seal cavity from escaping as the pump casing is removed.

Position a large (3 gallon [11,4 liter] minimum), **clean** container under the seal cavity drain plug (12). Remove the drain plug and drain the oil from the seal cavity into the container. Clean and reinstall the drain plug. Inspect the oil for water, dirt or a cloudy condition which could indicate seal failure.

### Loosening Impeller

#### (Figures C-3 and C-6)

With the pump end separated from the engine, insert a block of wood through the pump discharge and wedge it between the vanes of the impeller and the pump casing to prevent rotation. Remove the impeller capscrew and washer (21 and 22).

Install the shaft key (10) in the shaft keyway. Install a lathe dog on the drive end of the shaft (11) with the "V" notch positioned over the shaft key.

With the impeller rotation still blocked, see Figure C-6 and use a long piece of heavy bar stock to pry against the arm of the lathe dog in a counterclockwise direction (when facing the drive end of the shaft). **Use caution** not to damage the shaft or keyway. When the impeller breaks loose, remove the lathe dog, key and wood block.

### NOTE

*Do not remove the impeller until the rotating assembly has been removed from the pump casing.*

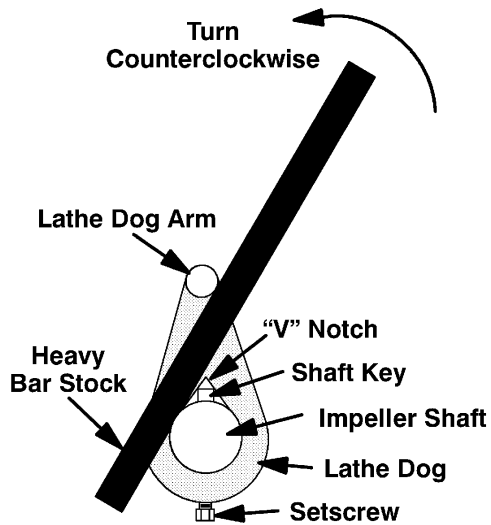

Figure C-6. Loosening Impeller

### Pump Casing Removal

(Figure C-2)

Support the pump casing using a suitable hoist and sling, and remove the hardware (9 and 10). Install four 1/2-13 UNC x 2-inch long jacking screws in the tapped holes in the bearing housing (4, Figure C-3). Tighten the jacking screws in an alternating pattern until the pump casing is pushed off of the bearing housing. Remove the jacking screws.

### Impeller Removal

(Figure C-3)

To remove the impeller (2), unscrew it in a counterclockwise direction (when facing the impeller). Use caution when removing the impeller; tension on the shaft seal spring will be released as the impeller is unscrewed. Inspect the impeller and replace it if cracked or badly worn.

### Seal Removal

(Figures C-3 and C-7)

Slide the impeller adjusting shims (29) off the impeller shaft (11). Tie and tag the shims or measure and record their thickness for ease of reassembly.

Remove the spring centering washer and seal spring. Slide the shaft sleeve (30) and rotating por-

tion of the seal (consisting of the bellows, retainer, and rotating element) off the shaft as a unit.

Apply oil to the sleeve and work it up under the rubber bellows. Slide the rotating portion of the seal off the sleeve.

Remove the seal sleeve O-ring (28).

Slide a pair of stiff wires with hooked ends along the shaft and hook the stationary seat from the back side. Pull the stationary seat and O-ring from the seal plate.

An alternate method of removing the stationary seal components is to remove the hardware (18 and 19) and separate the seal plate from the bearing housing (4). Position the seal plate on a flat surface with the impeller side down. Use a wooden dowel or other suitable tool to press on the back side of the stationary seat until the seat and O-ring can be removed.

Remove the seal plate O-ring (35).

If no further disassembly is required, refer to **Seal Installation**.

### Shaft and Bearing Removal and Disassembly

(Figure C-3)

When the pump is properly operated and maintained, the bearing housing should not require disassembly. Disassemble the shaft and bearings **only** when there is evidence of wear or damage.



Shaft and bearing disassembly in the field is not recommended. These operations should be performed only in a properly-equipped shop by qualified personnel.

Remove the bearing housing drain plug (24) and drain the lubricant. Clean and reinstall the drain plug.

Disengage the hardware (14 and 15) and remove the drive flange (9), gasket (16) and oil seal (12). Use a suitably sized dowel to press the oil seal from the drive flange.

Place a block of wood against the impeller end of the shaft (11) and tap the shaft and assembled bearings from the intermediate. Press the inboard oil seal (17) out of the bearing housing.

Remove the bearing housing O-ring (34).

After removing the shaft and bearings, clean and inspect the bearings **in place** as follows.



To prevent damage during removal from the shaft, it is recommended that bearings be cleaned and inspected **in place**. It is **strongly** recommended that the bearings be replaced **any** time the shaft and bearings are removed.

Clean the bearing housing, shaft and all component parts (except the bearings) with a soft cloth soaked in cleaning solvent. Inspect the parts for wear or damage and replace as necessary.



**Most cleaning solvents are toxic and flammable. Use them only in a well ventilated area free from excessive heat, sparks, and flame. Read and follow all precautions printed on solvent containers.**

Clean the bearings thoroughly in **fresh** cleaning solvent. Dry the bearings with filtered compressed air and coat with light oil.



Bearings must be kept free of all dirt and foreign material. Failure to do so will greatly shorten bearing life. **Do not** spin dry bearings. This may scratch the balls or races and cause premature bearing failure.

Rotate the bearings by hand to check for roughness or binding and inspect the bearing balls. If rotation is rough or the bearing balls are discolored, replace the bearings.

The bearing tolerances provide a tight press fit onto the shaft and a snug slip fit into the bearing housing. Replace the bearings, shaft, or bearing housing if the proper bearing fit is not achieved.

If bearing replacement is required, remove the snap ring (13) and use a bearing puller to remove the inboard and outboard bearings (3 and 8) from the shaft.

### Shaft and Bearing Reassembly and Installation (Figure C-3)

Inspect the shaft for distortion, nicks or scratches, or for thread damage on the impeller end. Dress small nicks and burrs with a fine file or emery cloth. Replace the shaft if defective.

Clean and inspect the bearings as indicated in **Shaft And Bearing Removal And Disassembly**.



To prevent damage during removal from the shaft, it is recommended that bearings be cleaned and inspected **in place**. It is **strongly** recommended that the bearings be replaced **any** time the shaft and bearings are removed.

#### NOTE

*The inboard bearing (3) comes from the manufacturer with a retaining ring installed on the bearing O.D. This retaining ring **must** be removed prior to installation.*

The bearings may be heated to ease installation. An induction heater, hot oil bath, electric oven, or hot plate may be used to heat the bearings. Bearings should **never** be heated with a direct flame or directly on a hot plate.

#### NOTE

*If a hot oil bath is used to heat the bearings, both the oil and the container must be **absolutely** clean. If the oil has been previously used, it must be **thoroughly** filtered.*

Heat the bearings to a uniform temperature **no higher than 250°F (120°C)**, and slide the bearings onto the shaft, one at a time, until they are fully seated. This should be done quickly, in one continuous motion, to prevent the bearings from cooling and sticking on the shaft.

After the bearings have been installed and allowed to cool, check to ensure that they have not moved away from the shaft shoulders in shrinking. If movement has occurred, use a suitably sized sleeve and a press to reposition the bearings against the shaft shoulders.

If heating the bearings is not practical, use a suitably sized sleeve, and an arbor (or hydraulic) press to install the bearings on the shaft.



When installing the bearings onto the shaft, **never** press or hit against the outer race, balls, or ball cage. Press **only** on the inner race.

Secure the outboard bearing (8) to the shaft with the retaining ring (13).

Apply a light coating of oil to the lip of the inboard oil seal (17) and press it into the bearing housing with the lip positioned as shown in Figure C-3. Press the oil seal into the housing until the face is **just flush** with the machined surface on the housing.

Slide the shaft and assembled bearings into the intermediate bore until the inboard bearing is fully seated against the bore shoulder. Use caution not to damage the lip seal on the shaft threads.



When installing the shaft and bearings into the bearing bore, push against the outer race. **Never** hit the balls or ball cage.

Apply a light coating of oil to the lip of the outboard oil seal (12) and press it into the drive flange (9) with the lip positioned as shown in Figure C-3. The

face of the oil seal should be just flush with the outer face of the drive flange.

Install the drive flange gasket (16) and secure the drive flange to the bearing housing with the hardware (14 and 15). **Be careful** not to damage the lip of the oil seal (12) on the shaft keyway.

Lubricate a new bearing housing O-ring (34) with grease and install it in the groove in the bearing housing.

Lubricate the bearings as indicated in **LUBRICATION** at the end of this section.

### Securing Bearing Housing And Drive Assembly To Engine

(Figure C-4)

Install the shaft key in the shaft keyway. Position the flexible portion of the coupling assembly (1) on the shaft as shown in Figure C-4.

#### NOTE

*The flexible portion of the coupling must be properly positioned on the shaft. The heads of the cap-screws in the center of the coupling **must be positioned away from the pump end of the shaft.***

Align the keyway in the bushing (2) with the shaft key, and slide it onto the shaft to the dimension shown in Figure C-4. Rotate the flexible portion of the coupling until the tapped holes for the two setscrews align with those in the bushing, and install the setscrews.



Make certain that the flexible portion of the coupling is mounted as shown in Figure C-4. **This is critical.** If the coupling is not properly positioned on the shaft, the coupling parts may not fully engage, or a pre-load condition can cause premature bearing failure.

The coupling must be positioned 1.44 inches (37 mm) from the end of the shaft. This will allow the two portions of the coupling to fully engage when the drive flange

is secured to the engine bellhousing, without pre-loading the bearings.

With the flexible portion of the coupling and the bushing properly positioned on the shaft, tighten the two setscrews in an alternating sequence until the bushing and coupling are fully secured. Torque the setscrews to 14.6 ft. lbs. (175 in. lbs. or 2 m. kg.).

If the complete coupling assembly is being replaced, apply 'Loctite Retaining Compound No. 242' or equivalent to the threads of the hardware (6 and 7), and secure the outer ring of the coupling to the engine flywheel by torquing the hardware to 45 ft. lbs. (540 in. lbs. or 6,2 m. kg.).

Using a suitable lifting device, position the assembled rotating assembly and coupling so the flexible portion of the coupling seats inside the outer ring attached to the engine flywheel.

#### NOTE

To ease installation, **lightly** lubricate the rubber portion of the coupling with a **non-petroleum based lubricant** such as vegetable oil or glycerin, or a silicon-based lubricant such as "WD40" or equivalent. **Do not** use petroleum-based lubricants, or any other substance which may soften or otherwise damage the rubber.

Install the intermediate guards (27, Figure C-3), and secure the intermediate to the engine bellhousing with the previously removed hardware (8 and 9).

#### Seal Reassembly and Installation (Figures C-3 and C-7)

Clean the seal cavity and shaft with a cloth soaked in fresh cleaning solvent.



**Most cleaning solvents are toxic and flammable. Use them only in a well ventilated area free from excessive heat, sparks, and flame. Read and follow all precautions printed on solvent containers.**

The seal is not normally reused because wear patterns on the finished faces cannot be realigned during reassembly. This could result in premature failure. If necessary to reuse an old seal in an emergency, **carefully** wash all metallic parts in **fresh** cleaning solvent and allow to dry thoroughly.

Handle the seal parts with extreme care to prevent damage. Be careful not to contaminate precision finished faces; even fingerprints on the faces can shorten seal life. If necessary, clean the faces with a non-oil based solvent and a clean, lint-free tissue. Wipe **lightly** in a concentric pattern to avoid scratching the faces.

Inspect the seal components for wear, scoring, grooves, and other damage that might cause leakage. Clean and polish the shaft sleeve, or replace it if there are nicks or cuts on either end. If any components are worn, replace the complete seal; **never mix old and new seal parts.**

If a replacement seal is being used, remove it from the container and inspect the precision finished faces to ensure that they are free of any foreign matter.

To ease installation of the seal, lubricate the O-rings and bellows with water or a very **small** amount of oil, and apply a drop of light lubricating oil on the finished faces. Assemble the seal as follows, (see Figure C-7).

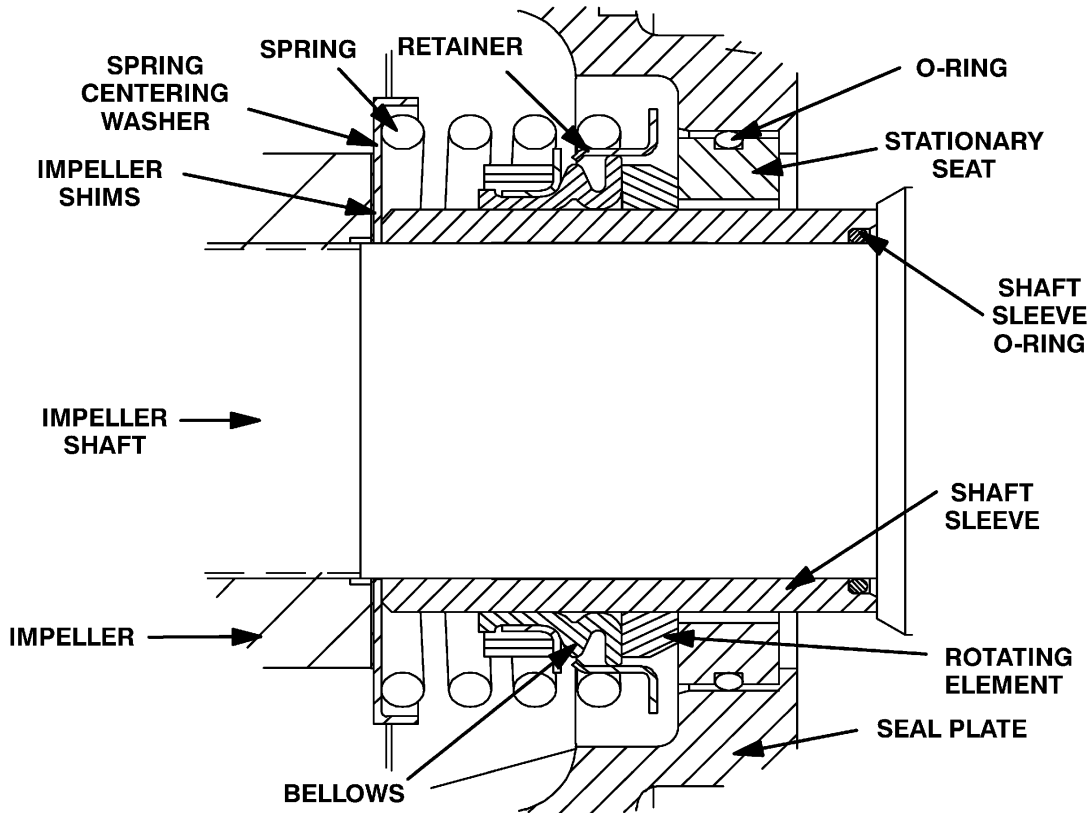

Figure C-7. Seal Assembly



## CAUTION

This seal is not designed for operation at temperatures above 160°F (71°C). Do not use at higher operating temperatures.

Lubricate the stationary seat O-ring with water or light oil. Press the stationary seat into the seal plate (20) until fully seated.

Position the seal plate over the shaft and secure it to the bearing housing (4) with the hardware (18 and 19). **Be careful** not to damage the stationary seat on the shaft threads.

Lubricate a new seal plate O-ring (35) with grease and install it in the groove in the seal plate.

Lubricate the shaft sleeve O-ring (28) and position it over the last thread on the impeller shaft. **Use caution** not to cut the O-ring on the threads.

Slide the shaft sleeve (30) onto the shaft until the O-ring is fully seated in the undercut. Continue to

press the sleeve onto the shaft until fully seated against the shaft shoulder.

Lubricate the O.D. of the seal sleeve with a **small** amount of light oil. Slide the rotating subassembly (consisting of rotating element, bellows and retainer), onto the sleeve until the seal faces contact.

Install the seal spring and centering washer. Lubricate the seal as indicated in **LUBRICATION** after the impeller is installed.

### Impeller Installation And Adjustment

#### (Figure C-3)

Inspect the impeller (1) and replace it if cracked or badly worn.



## CAUTION

The shaft and impeller threads **must** be completely clean before reinstalling the impeller. Even the slightest amount of dirt on the threads can cause the impeller to seize

to the shaft, making future removal difficult or impossible without damage to the impeller or shaft.

Install the same thickness of impeller adjusting shims (29) as previously removed and screw the impeller assembly onto the shaft until tight.

### NOTE

*At the slightest sign of binding, **immediately** back the impeller off, and check the threads for dirt. **Do not** try to force the impeller onto the shaft.*

A clearance of .025 to .040 inch (0,64 to 1,02 mm) between the impeller and the seal plate is necessary for maximum pump efficiency. Measure this clearance, and add or remove impeller adjusting shims as required.

Secure the impeller to the shaft with the impeller washer and capscrew (21 and 22).

### Back Cover Plate And Wear Ring Installation

#### (Figure C-2)

It is recommended that the back cover (15) and wear ring (5) be installed in the pump casing (1) before the pump casing is installed. Lubricate the O-rings (6 and 14) with grease and install them in the grooves in the wear ring and back cover.

Secure the wear ring to the back cover with the hardware (3 and 4).

Slide the assembled back cover and wear ring into the pump casing with the priming chamber port on the back cover facing up. Do not install the adjusting shims (16) at this time. Secure the back cover to the pump casing with the lockwashers and hand knobs (18 and 19).

### Pump Casing Installation

#### (Figure C-2)

Lubricate the rotating assembly O-rings (34 and 35, Figure C-3) with a light coating of grease. Use a suitable hoist and sling to slide the pump casing (1) over the rotating assembly.

Measure the gap between the pump casing and the bearing housing at the locations for the rotating assembly mounting hardware (9 and 10). Assemble the shims (11) into sets equalling 1/2 this measurement.

Loosen the hand knobs (19) approximately 1/4". Install the shim sets (11) and secure the pump casing to the rotating assembly (2) with the hardware (9 and 10).

Reach through the suction opening in the back cover and measure the clearance between the impeller and wear ring. This clearance should be between .010 and .012 inch (0,25 and 0,3 mm). Install the required thickness of adjusting shims (16) until this clearance is achieved.

Fully tighten the hand knobs (19).

### Priming Chamber Assembly And Installation

#### (Figure C-5)

Assemble the valve strap (18), guide plates (12), and protectors (33), and **loosely** attach them to the bracket assembly (16) with the hardware (13, 14 and 15). The smooth side of the valve strap **must** be positioned **away from** the bracket assembly.

Position the priming chamber lid (1) upside down on a flat work surface. Install the preassembled valve strap and bracket over the studs (27). Allow the valve strap to fully wrap over the peeler valve to ensure a proper seal without any wrinkles in the strap, and fully tighten the hardware (13, 14, and 15).

Position the clamp plate (17) over the studs (27). Apply "Loctite Threadlocker No. 242" or equivalent compound to the studs, and secure with the lock nuts (28).

Lay the lid and preassembled valve strap components on its side. Apply "Loctite Threadlocker No. 242" or equivalent compound to the capscrews (29) and secure the bracket assembly (16) to the float (31) with the hardware (29 and 30).

Apply 3-M Scotchgrip Adhesive No. 847" or equivalent compound to the linear O-ring (9) and install the O-ring in the groove in the priming chamber lid (1).

**NOTE**

*Cut the lap joint where the two ends of the O-ring (9) meet at a 45° angle.*

Carefully lower the assembled lid and float into the valve body (33). Secure the lid to the body with the hardware (10 and 11).

If removed, install the gasket (5) and secure the valve plate (6) to the lid with the hardware (7 and 8).

If the check valve (19) was disassembled for replacement, install the sealing washer (26) against the head of the capscrew (25). Install the large valve weight (25) against the sealing washer. Install the check valve (20) and small valve weight (23), and secure the assembly with the lockwasher and hex nut (21 and 22).

Position the check valve assembly over the holes in the valve plate (5) with the large weight (25) facing up. Position the valve neck (2) over the check valve assembly and secure with the hardware (3 and 4).

**(Figure C-1)**

Install the gasket (3) and use a sling and suitable lifting device to position the priming chamber assembly against the baffle plate (2) and cover plate (5, Figure C-2). Secure the priming chamber assembly with the hardware (4 and 5).

Reconnect both the suction piping and the air discharge tubing to the priming chamber assembly.

**Discharge Check Valve Assembly And Installation****(Figure C-1)**

The flapper and gasket are the only serviceable parts of the check valve (6). If the flapper requires replacement, remove the hardware securing the cover and gasket. Separate the valve cap and replace the flapper.

Install the valve cap gasket and secure the cap with the previously removed hardware.

Install the discharge check valve assembly in the discharge piping with the hardware (7, 8 and 9).

**Wear Ring Adjustment****(Figure C-2)**

Pump performance is adversely affected by increased clearance between the wear ring (5) and the impeller. When it becomes necessary to adjust the clearance, loosen the hand knobs (19).

Reach through the suction opening and measure the clearance between the wear ring and impeller. Remove adjusting shims until the clearance between the impeller and wear ring is between .010 and .012 inch (0,25 and 0,3 mm). When the proper clearance is achieved, tighten the hand knobs (19).

When proper clearance can no longer be achieved by removing the back cover shims, loosen the hand knobs and install jacking screws in the back cover. Tighten the jacking screws to pull the back cover approximately 1/4" (6,4 mm) out of the pump casing.

Remove the hardware (9 and 10) securing the pump casing to the rotating assembly. Remove the shims (11) and re-install the hardware (9 and 10).

Adjust the wear ring - to - impeller clearance as previously described.

**LUBRICATION****Seal Assembly****(Figure C-2)**

Fill the seal cavity through the hole for the vented plug (8) with SAE No. 30 non-detergent oil. Check the oil level regularly and refill as required. When lubricating a dry seal cavity, add approximately 256 oz. or 8 U.S. quarts (7,6 liters) of oil to level indicated.

**Bearings****(Figure C-3)**

The bearing housing was fully lubricated when shipped from the factory. Check the oil level regularly through the sight gauge (26) and maintain it at the midpoint of the gauge. When lubrication is required, remove the air vent (6) and add SAE No. 30 non-detergent oil through the opening. When lubricating a dry (overhauled) bearing housing, fill the

bearing cavity with approximately 40 ounces (1,2 liters) of oil. Clean and reinstall the air vent. **Do not** over-lubricate. Over-lubrication can cause the bearings to over-heat, resulting in premature bearing failure.

#### **NOTE**

*The white reflector in the sight gauges must be positioned horizontally to provide proper drainage.*

---

Under normal conditions, drain the bearing housing once each year and refill with clean oil. Change the oil more frequently if the pump is operated continuously or installed in an environment with rapid temperature change.



Monitor the condition of the bearing lubricant regularly for evidence of rust or moisture condensation. This is especially important in areas where variable hot and cold temperatures are common.

For cold weather operation, consult the factory or a lubricant supplier for the recommended grade of oil.

#### **Power Unit**

Consult the literature supplied with the power unit, or contact your local power unit representative.

**For U.S. and International Warranty Information,  
Please Visit [www.grpumps.com/warranty](http://www.grpumps.com/warranty)  
or call:  
U.S.: 419-755-1280  
International: +1-419-755-1352**

**For Canadian Warranty Information,  
Please Visit [www.grcanada.com/warranty](http://www.grcanada.com/warranty)  
or call:  
519-631-2870**