

# INSTALLATION, OPERATION, AND MAINTENANCE MANUAL

WITH PARTS LIST



CANADA

## 10 SERIES PUMP

MODEL
<b>16A2-4045T</b>

**THE GORMAN-RUPP COMPANY • MANSFIELD, OHIO**

[www.grpumps.com](http://www.grpumps.com)

GORMAN-RUPP OF CANADA LIMITED • ST. THOMAS, ONTARIO, CANADA Printed in U.S.A.

©2012 The Gorman-Rupp Company

Register your new  
Gorman-Rupp pump online at  
**www.grpumps.com**

Valid serial number and e-mail address required.



**The engine exhaust from this product contains chemicals known to the State of California to cause cancer, birth defects or other reproductive harm.**

### **RECORD YOUR PUMP MODEL AND SERIAL NUMBER**

Please record your pump model and serial number in the spaces provided below. Your Gorman-Rupp distributor needs this information when you require parts or service.

Pump Model: \_\_\_\_\_

Serial Number: \_\_\_\_\_

# TABLE OF CONTENTS

<b>INTRODUCTION</b> .....	<b>PAGE I – 1</b>
<b>SAFETY – SECTION A</b> .....	<b>PAGE A – 1</b>
<b>INSTALLATION – SECTION B</b> .....	<b>PAGE B – 1</b>
Pump Dimensions .....	PAGE B – 1
<b>PREINSTALLATION INSPECTION</b> .....	PAGE B – 1
Battery Specifications And Installation .....	PAGE B – 2
<b>POSITIONING PUMP</b> .....	PAGE B – 2
Lifting .....	PAGE B – 2
Mounting .....	PAGE B – 2
Clearance .....	PAGE B – 3
<b>SUCTION AND DISCHARGE PIPING</b> .....	PAGE B – 3
Materials .....	PAGE B – 3
Line Configuration .....	PAGE B – 3
Connections to Pump .....	PAGE B – 3
Gauges .....	PAGE B – 3
<b>SUCTION LINES</b> .....	PAGE B – 3
Fittings .....	PAGE B – 3
Strainers .....	PAGE B – 3
Sealing .....	PAGE B – 4
Suction Lines In Sumps .....	PAGE B – 4
Suction Line Positioning .....	PAGE B – 4
<b>DISCHARGE LINES</b> .....	PAGE B – 5
Siphoning .....	PAGE B – 5
Valves .....	PAGE B – 5
Bypass Lines .....	PAGE B – 5
<b>AUTOMATIC AIR RELEASE VALVE</b> .....	PAGE B – 6
Theory of Operation .....	PAGE B – 6
Air Release Valve Installation .....	PAGE B – 7
<b>ALIGNMENT</b> .....	PAGE B – 8
<b>OPERATION – SECTION C</b> .....	<b>PAGE C – 1</b>
<b>PRIMING</b> .....	PAGE C – 1
<b>STARTING</b> .....	PAGE C – 1
<b>OPERATION</b> .....	PAGE C – 1
Lines With a Bypass .....	PAGE C – 1
Lines Without a Bypass .....	PAGE C – 2
Leakage .....	PAGE C – 2
Liquid Temperature And Overheating .....	PAGE C – 2
Strainer Check .....	PAGE C – 2
Pump Vacuum Check .....	PAGE C – 2
<b>STOPPING</b> .....	PAGE C – 3
Cold Weather Preservation .....	PAGE C – 3
<b>BEARING TEMPERATURE CHECK</b> .....	PAGE C – 3
<b>TROUBLESHOOTING – SECTION D</b> .....	<b>PAGE D – 1</b>

**TABLE OF CONTENTS**  
**(continued)**

<b>PUMP MAINTENANCE AND REPAIR – SECTION E .....</b>	<b>PAGE E – 1</b>
PERFORMANCE CURVE .....	PAGE E – 1
PARTS LISTS:	
PUMP MODEL ASSEMBLY .....	PAGE E – 3
POWER UNIT .....	PAGE E – 5
PUMP END ASSY .....	PAGE E – 7
DRIVE ASSEMBLY .....	PAGE E – 8
PUMP AND SEAL DISASSEMBLY AND REASSEMBLY .....	PAGE E – 9
Back Cover Removal .....	PAGE E – 9
Suction Check Valve Removal .....	PAGE E – 10
Pump Casing Removal .....	PAGE E – 10
Impeller Removal .....	PAGE E – 10
Seal Removal and Disassembly .....	PAGE E – 10
Separating Intermediate And Drive Assembly From Engine .....	PAGE E – 11
Shaft and Bearing Removal and Disassembly .....	PAGE E – 11
Shaft and Bearing Reassembly and Installation .....	PAGE E – 12
Securing Intermediate And Drive Assembly To Engine .....	PAGE E – 13
Seal Reassembly and Installation .....	PAGE E – 14
Impeller Installation And Adjustment .....	PAGE E – 16
Suction Check Valve Installation .....	PAGE E – 16
Back Cover Installation .....	PAGE E – 16
Final Pump Assembly .....	PAGE E – 17
LUBRICATION .....	PAGE E – 17
Seal Assembly .....	PAGE E – 17
Bearings .....	PAGE E – 18
Engine .....	PAGE E – 18

## INTRODUCTION

**Thank You** for purchasing a Gorman-Rupp pump. **Read this manual** carefully to learn how to safely install and operate your pump. Failure to do so could result in personal injury or damage to the pump.

This manual will alert personnel to known procedures which require special attention, to those which could damage equipment, and to those which could be dangerous to personnel. However, this manual cannot possibly anticipate and provide detailed precautions for every situation that might occur during maintenance of the unit. Therefore, it is the responsibility of the owner/maintenance personnel to ensure that **only** safe, established maintenance procedures are used, and that any procedures not addressed in this manual are performed **only** after establishing that neither personal safety nor pump integrity are compromised by such practices.

This pump is a 10 Series, semi-open impeller, self-priming centrifugal model with a suction check valve. The pump is powered by a John Deere diesel engine, model 4045T. The pump is designed for handling dirty water containing specified entrained solids. The basic material of construction for wetted parts is gray iron, with ductile iron impeller and steel wearing parts.

If there are any questions regarding the pump or its application which are not covered in this manual or in other literature accompanying this unit, please contact your Gorman-Rupp distributor, or The Gorman-Rupp Company:

**The Gorman-Rupp Company**  
**P.O. Box 1217**  
**Mansfield, Ohio 44901-1217**  
**Phone: (419) 755-1011**  
 or:  
**Gorman-Rupp of Canada Limited**  
**70 Burwell Road**  
**St. Thomas, Ontario N5P 3R7**  
**Phone: (519) 631-2870**

For information or technical assistance on the engine, contact the engine manufacturer's local dealer or representative.

The following are used to alert maintenance personnel to procedures which require special attention, to those which could damage equipment, and to those which could be dangerous to personnel:



**Immediate hazards which WILL result in severe personal injury or death. These instructions describe the procedure required and the injury which will result from failure to follow the procedure.**



**Hazards or unsafe practices which COULD result in severe personal injury or death. These instructions describe the procedure required and the injury which could result from failure to follow the procedure.**



Hazards or unsafe practices which COULD result in minor personal injury or product or property damage. These instructions describe the requirements and the possible damage which could result from failure to follow the procedure.

### NOTE

*Instructions to aid in installation, operation, and maintenance, or which clarify a procedure.*

## SAFETY – SECTION A

This information applies to 10 Series engine driven pumps. Refer to the manual accompanying the engine before attempting to begin operation.

Because pump installations are seldom identical, this manual cannot possibly provide detailed instructions and precautions for each specific application. Therefore, it is the owner/installer's responsibility to ensure that applications not addressed in this manual are performed only after establishing that neither operator safety nor pump integrity are compromised by the installation.



Before attempting to open or service the pump:

1. Familiarize yourself with this manual.
2. Switch off the engine ignition and disconnect the positive battery cable to ensure that the pump will remain inoperative.
3. Allow the pump to completely cool if overheated.
4. Check the temperature before opening any covers, plates, or plugs.
5. Close the suction and discharge valves.
6. Vent the pump slowly and cautiously.
7. Drain the pump.



This pump is designed to handle dirty water containing specified entrained solids. Do not attempt to pump volatile,

corrosive, or flammable materials, or any liquids which may damage the pump or endanger personnel as a result of pump failure.



Use lifting and moving equipment in good repair and with adequate capacity to prevent injuries to personnel or damage to equipment. The bail is intended for use in lifting the pump assembly only. Suction and discharge hoses and piping must be removed from the pump before lifting.



After the pump has been positioned, make certain that the pump and all piping or hose connections are tight, properly supported and secure before operation.



Do not operate the pump against a closed discharge valve for long periods of time. If operated against a closed discharge valve, pump components will deteriorate, and the liquid could come to a boil, build pressure, and cause the pump casing to rupture or explode.



Do not remove plates, covers, gauges, pipe plugs, or fittings from an overheated pump. Vapor pressure within the pump can cause parts being disengaged to be ejected with great force. Allow the pump to cool before servicing.



Do not operate an internal combustion engine in an explosive atmosphere. When operating internal combustion engines in an enclosed area, make certain that exhaust fumes are piped to the outside. These fumes contain carbon monoxide, a deadly gas that is colorless, tasteless, and odorless.



Fuel used by internal combustion en-

gines presents an extreme explosion and fire hazard. Make certain that all fuel lines are securely connected and free of leaks. Never refuel a hot or running engine. Avoid overfilling the fuel tank. Always use the correct type of fuel.



Never tamper with the governor to gain more power. The governor establishes safe operating limits that should not be exceeded. Refer to the performance curve on page E-1 for the maximum continuous operating speed for this pump.

## INSTALLATION – SECTION B

**Review all SAFETY information in Section A.**

Since pump installations are seldom identical, this section offers only general recommendations and practices required to inspect, position, and arrange the pump and piping.

Most of the information pertains to a standard **static lift** application where the pump is positioned above the free level of liquid to be pumped.

If installed in a **flooded suction application** where the liquid is supplied to the pump under pressure, some of the information such as mounting, line configuration, and priming must be tailored to the specific application. Since the pressure supplied

to the pump is critical to performance and safety, **be sure** to limit the incoming pressure to **50%** of the maximum permissible operating pressure as shown on the pump performance curve (see Section E, Page 1). If the pump is fitted with a Gorman-Rupp double grease lubricated seal, the maximum incoming pressure must be reduced to 10 p.s.i.

For further assistance, contact your Gorman-Rupp distributor or the Gorman-Rupp Company.

**Pump Dimensions**

See Figure 1 for the approximate physical dimensions of this pump.

**OUTLINE DRAWING**

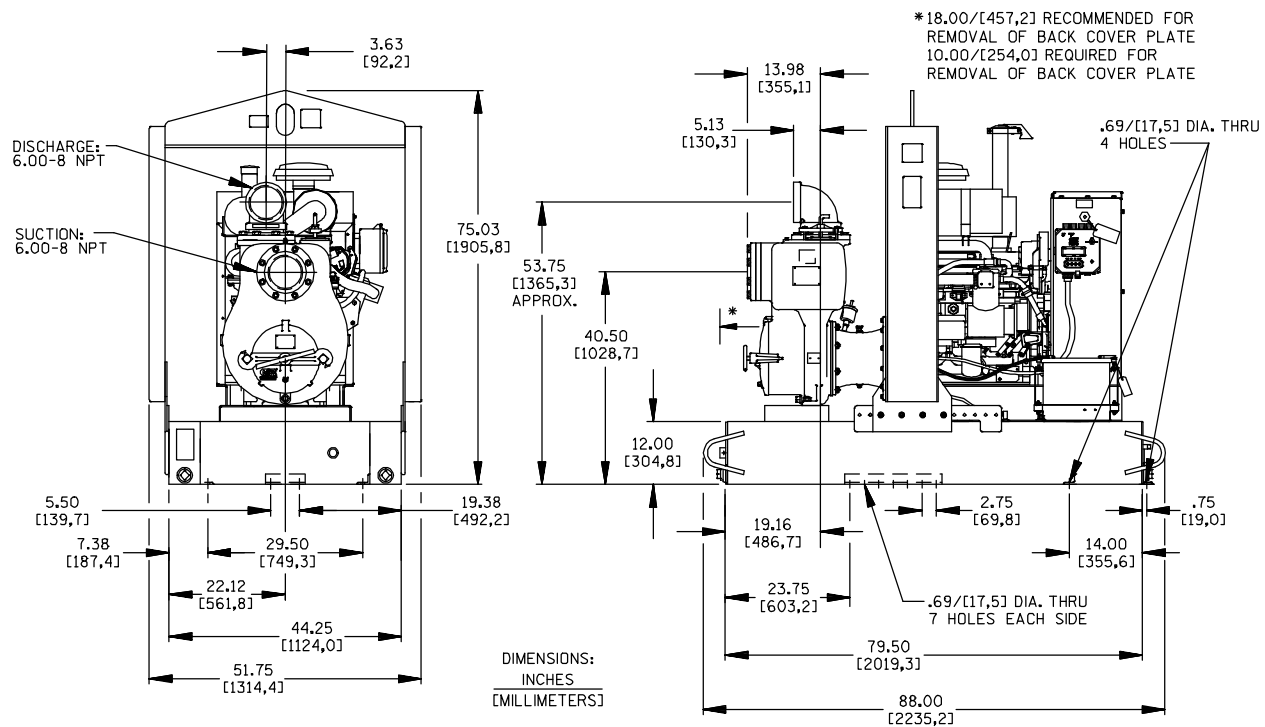

**Figure 1. Pump Model 16A2-4045T**



## PREINSTALLATION INSPECTION

The pump assembly was inspected and tested before shipment from the factory. Before installation, inspect the pump for damage which may have occurred during shipment. Check as follows:

- a. Inspect the pump for cracks, dents, damaged threads, and other obvious damage.
- b. Check for and tighten loose attaching hardware. Since gaskets tend to shrink after drying, check for loose hardware at mating surfaces.
- c. Carefully read all tags, decals, and markings on the pump assembly, and follow the instructions indicated.
- d. Check levels and lubricate as necessary. Refer to **LUBRICATION** in the **MAINTENANCE AND REPAIR** section of this manual and perform duties as instructed.
- e. If the pump and engine have been stored for more than 12 months, some of the components or lubricants may have exceeded their maximum shelf life. These **must be inspected or replaced** to ensure maximum pump service.

If the maximum shelf life has been exceeded, or if anything appears to be abnormal, contact your Gorman-Rupp distributor or the factory to determine the repair or updating policy. **Do not** put the pump into service until appropriate action has been taken.

### Battery Specifications And Installation

Unless otherwise specified on the pump order, the engine battery was **not** included with the unit. Refer to the following specifications when selecting a battery.

**Table 1. Battery Specifications**

Voltage	Cold Crank Amps @ 0° F	Reserve Capacity @ 80° F (Minutes)	Amp/ Hr. Rating	Approx. Overall Dims. (Inches)
12 Volts	960-975	365	175	20.5L X 8.75W X 9.75H

Refer to the information accompanying the battery and/or electrolyte solution for activation and charging instructions.

Before installing the battery, clean the positive and negative cable connectors, and the battery terminals. Secure the battery by tightening the holddown brackets. The terminals and clamps may be coated with petroleum jelly to retard corrosion. Connect and tighten the positive cable first, then the negative cable.

## POSITIONING PUMP



**WARNING!**

**Use lifting and moving equipment in good repair and with adequate capacity to prevent injuries to personnel or damage to equipment. The bail is intended for use in lifting the pump assembly only. Suction and discharge hoses and piping must be removed from the pump before lifting.**

### Lifting

Pump unit weights will vary depending on the mounting and drive provided. Check the shipping tag on the unit packaging for the actual weight, and use lifting equipment with appropriate capacity. Drain the pump and remove all customer-installed equipment such as suction and discharge hoses or piping before attempting to lift existing, installed units.



**CAUTION**

The pump assembly can be seriously

damaged if the cables or chains used to lift and move the unit are improperly wrapped around the pump.

### Mounting

Locate the pump in an accessible place as close as practical to the liquid being pumped. Level mounting is essential for proper operation.

If the pump has been mounted on a movable base, make certain the base is stationary by setting the brake and blocking the wheels before attempting to operate the pump.

To ensure sufficient lubrication and fuel supply to the engine, **do not** position the pump and engine more than 15° off horizontal for continuous operation. The pump and engine may be positioned up to 30° off horizontal for **intermittent operation only**; however, the engine manufacturer should be consulted for continuous operation at angles greater than 15°.

### Clearance

When positioning the pump, allow a minimum clearance of **18 inches (457 mm)** in front of the back cover to permit removal of the cover and easy access to the pump interior.

## SUCTION AND DISCHARGE PIPING

Pump performance is adversely effected by increased suction lift, discharge elevation, and friction losses. See the performance curve and operating range shown on Page E-1 to be sure your overall application allows pump to operate within the safe operation range.

### Materials

Either pipe or hose may be used for suction and discharge lines; however, the materials must be compatible with the liquid being pumped. If hose is used in suction lines, it must be the rigid-wall, reinforced type to prevent collapse under suction. Using piping couplings in suction lines is not recommended.

### Line Configuration

Keep suction and discharge lines as straight as possible to minimize friction losses. Make minimum use of elbows and fittings, which substantially increase friction loss. If elbows are necessary, use the long-radius type to minimize friction loss.

### Connections to Pump

Before tightening a connecting flange, align it exactly with the pump port. Never pull a pipe line into place by tightening the flange bolts and/or couplings.

Lines near the pump must be independently supported to avoid strain on the pump which could cause excessive vibration, decreased bearing life, and increased shaft and seal wear. If hose-type lines are used, they should have adequate support to secure them when filled with liquid and under pressure.

### Gauges

Most pumps are drilled and tapped for installing discharge pressure and vacuum suction gauges. If these gauges are desired for pumps that are not tapped, drill and tap the suction and discharge lines not less than 18 inches (457,2 mm) from the suction and discharge ports and install the lines. Installation closer to the pump may result in erratic readings.

## SUCTION LINES

To avoid air pockets which could affect pump priming, the suction line must be as short and direct as possible. When operation involves a suction lift, the line must always slope upward to the pump from the source of the liquid being pumped; if the line slopes down to the pump at any point along the suction run, air pockets will be created.

### Fittings

Suction lines should be the same size as the pump inlet. If reducers are used in suction lines, they should be the eccentric type, and should be installed with the flat part of the reducers uppermost to avoid creating air pockets. Valves are not normally used in suction lines, but if a valve is used,

install it with the stem horizontal to avoid air pockets.

### Strainers

If a strainer is furnished with the pump, be certain to use it; any spherical solids which pass through a strainer furnished with the pump will also pass through the pump itself.

If a strainer is not furnished with the pump, but is installed by the pump user, make certain that the total area of the openings in the strainer is at least three or four times the cross section of the suction line, and that the openings will not permit passage of solids larger than the solids handling capability of the pump.

This pump is designed to handle up to 2.5 inch (63,5 mm) diameter spherical solids.

### Sealing

Since even a slight leak will affect priming, head, and capacity, especially when operating with a high suction lift, all connections in the suction line should be sealed with pipe dope to ensure an airtight seal. Follow the sealant manufacturer's recommendations when selecting and applying the pipe dope. The pipe dope should be compatible with the liquid being pumped.

### Suction Lines In Sumps

If a single suction line is installed in a sump, it should be positioned away from the wall of the

sump at a distance equal to 1 1/2 times the diameter of the suction line.

If there is a liquid flow from an open pipe into the sump, the flow should be kept away from the suction inlet because the inflow will carry air down into the sump, and air entering the suction line will reduce pump efficiency.

If it is necessary to position inflow close to the suction inlet, install a baffle between the inflow and the suction inlet at a distance 1 1/2 times the diameter of the suction pipe. The baffle will allow entrained air to escape from the liquid before it is drawn into the suction inlet.

If two suction lines are installed in a single sump, the flow paths may interact, reducing the efficiency of one or both pumps. To avoid this, position the suction inlets so that they are separated by a distance equal to at least 3 times the diameter of the suction pipe.

### Suction Line Positioning

The depth of submergence of the suction line is critical to efficient pump operation. Figure 2 shows recommended minimum submergence vs. velocity.

#### NOTE

*The pipe submergence required may be reduced by installing a standard pipe increaser fitting at the end of the suction line. The larger opening size will reduce the inlet velocity. Calculate the required submergence using the following formula based on the increased opening size (area or diameter).*

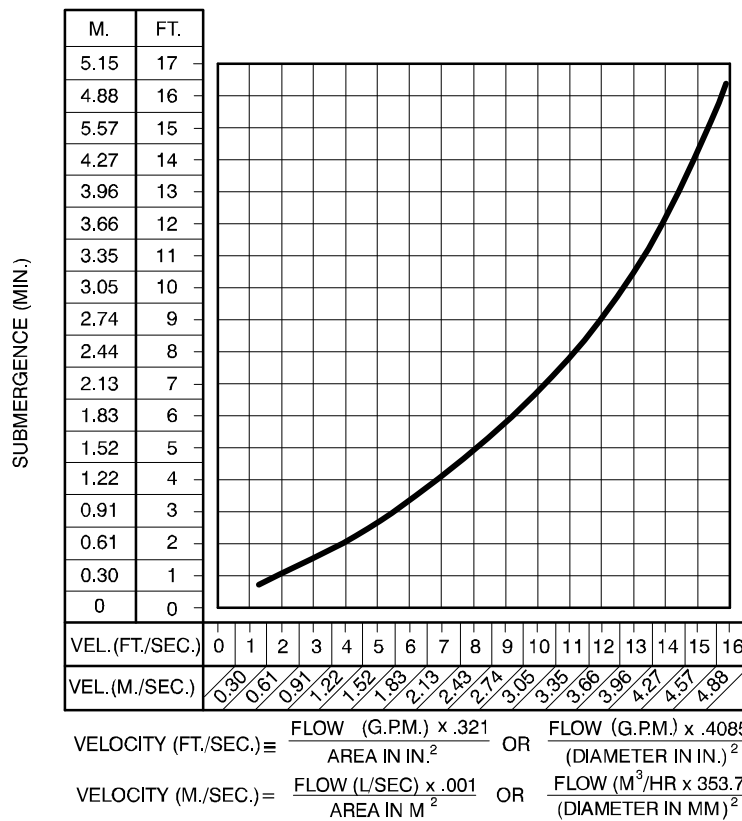

Figure 2. Recommended Minimum Suction Line Submergence vs. Velocity

**DISCHARGE LINES**

**Siphoning**

Do not terminate the discharge line at a level lower than that of the liquid being pumped unless a siphon breaker is used in the line. Otherwise, a siphoning action causing damage to the pump could result.

**Valves**

If a throttling valve is desired in the discharge line, use a valve as large as the largest pipe to minimize friction losses. Never install a throttling valve in a suction line.

With high discharge heads, it is recommended that a throttling valve and a system check valve be installed in the discharge line to protect the pump from excessive shock pressure and reverse rotation when it is stopped.



If the application involves a high discharge head, gradually close the discharge throttling valve before stopping the pump.

**Bypass Lines**

Self-priming pumps are not air compressors. During the priming cycle, air from the suction line must be vented to atmosphere on the discharge side. If the discharge line is open, this air will be vented through the discharge. However, if a check valve has been installed in the discharge line, the discharge side of the pump must be opened to atmospheric pressure through a bypass line installed between the pump discharge and the check valve. A self-priming centrifugal pump **will not prime** if there is sufficient static liquid head to hold the discharge check valve closed.

**NOTE**

*The bypass line should be sized so that it does not affect pump discharge capacity; however, the bypass line should be at least 1 inch (25,4 mm) in di-*

ameter to minimize the chance of plugging.

In **low discharge head applications** (less than 30 feet (9,1 m)), it is recommended that the bypass line be run back to the wet well, and located 6 inches below the water level or cut-off point of the low level pump. In some installations, this bypass outline may be terminated with a six-to-eight foot (1,8 to 2,4 m) length of 1-1/4 inch (31,8 mm) I.D. **smooth-bore** hose; air and liquid vented during the priming process will then agitate the hose and break up any solids, grease, or other substances likely to cause clogging.



A bypass line that is returned to a wet well must be secured against being drawn into the pump suction inlet.

It is also recommended that pipe unions be installed at each 90° elbow in a bypass line to ease disassembly and maintenance.

In **high discharge head applications** (more than 30 feet (9,1 m)), an excessive amount of liquid may be bypassed and forced back to the wet well under the full working pressure of the pump; this will reduce overall pumping efficiency. **Therefore, it is recommended that a Gorman-Rupp Automatic Air Release Valve be installed in the bypass line.**

Gorman-Rupp Automatic Air Release Valves are reliable, and require minimum maintenance. See **Automatic Air Release Valves** in this section for installation and theory of operation of the Automatic Air Release Valve. Consult your Gorman-Rupp distributor, or contact the Gorman-Rupp Company for selection of an Automatic Air Release Valve to fit your application.



Except in certain specific applications (to prevent flooding during service of an automatic air release valve in a below-ground lift station), if a manual shut-off valve is installed **anywhere** in a bypass line, it **must**

be a full-opening, **ball-type** valve to prevent plugging by solids.



**A manual shut-off valve should not be installed in any bypass line. A manual shut-off valve may inadvertently be left closed during operation. A pump which has lost prime may continue to operate without reaching prime, causing dangerous overheating and possible explosive rupture of the pump casing. Personnel could be severely injured.**

**Allow an over-heated pump to completely cool before servicing. Do not remove plates, covers, gauges, or fittings from an over-heated pump. Liquid within the pump can reach boiling temperatures, and vapor pressure within the pump can cause parts being disengaged to be ejected with great force. After the pump completely cools, drain the liquid from the pump by removing the casing drain plug. Use caution when removing the plug to prevent injury to personnel from hot liquid.**

## AUTOMATIC AIR RELEASE VALVE

When properly installed, a Gorman-Rupp Automatic Air Release Valve will permit air to escape through the bypass line and then close automatically when the pump is fully primed and pumping at full capacity.



**Some leakage (1 to 5 gallons [3.8 to 19 liters] per minute) will occur when the valve is fully closed. Be sure the bypass line is directed back to the wet well or tank to prevent hazardous spills.**

Consult the manual accompanying the Air Release Valve for additional information on valve installation and performance.

## Air Release Valve Installation

The Automatic Air Release Valve must be independently mounted in a horizontal position be-

tween the pump discharge port and the inlet side of the discharge check valve (see Figure 3). The inlet opening in the Air Release Valve is equipped with standard 1-inch NPT pipe threads.

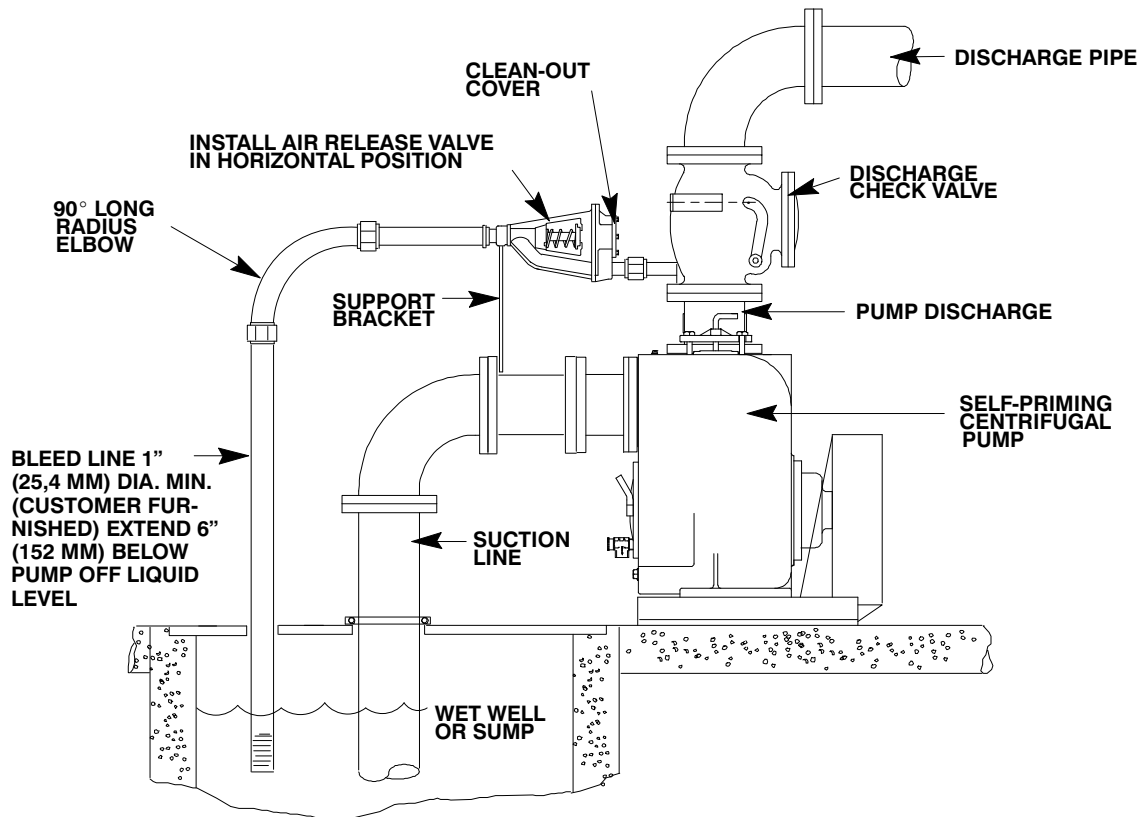

**Figure 3. Typical Automatic Air Release Valve Installation**

Connect the valve outlet to a bleed line which slopes back to the wet well or sump. The bleed line must be the same size as the outlet opening or larger, depending on which Air Release Valve is being used. If **pipng** is used for the bleed line, avoid the use of elbows whenever possible.

### NOTE

*For multiple pump installations, it is recommended that each Air Release Valve be fitted with an independent bleeder line directed back to the wet well. If multiple Air Release Valves are installed in a system, **do not** direct bleeder lines to a common mani-*

*fold pipe. Contact your Gorman-Rupp distributor or the Gorman-Rupp Company for information about installation of an Automatic Air Release Valve for your specific application.*

### ALIGNMENT

The alignment of the pump and the engine is critical for trouble-free mechanical operation. See Section E, **Securing Intermediate And Drive Assembly To Engine** for detailed information.

## OPERATION – SECTION C

Review all SAFETY information in Section A.

Follow the instructions on all tags, labels and decals attached to the pump.



This pump is designed to handle dirty water containing specified entrained solids. Do not attempt to pump volatile, corrosive, or flammable materials, or any liquids which may damage the pump or endanger personnel as a result of pump failure.



Never tamper with the governor to gain more power. The governor establishes safe operating limits that should not be exceeded. Refer to the performance curve on page E-1 for the maximum continuous operating speed for this pump.

### PRIMING

Install the pump and piping as described in **INSTALLATION**. Make sure that the piping connections are tight, and that the pump is securely mounted. Check that the pump is properly lubricated (see **LUBRICATION** in **MAINTENANCE AND REPAIR**).

This pump is self-priming, but the pump should never be operated unless there is liquid in the pump casing.



Never operate this pump unless there is liquid in the pump casing. The pump will not prime when dry. Extended operation of a dry pump will destroy the seal assembly.

Add liquid to the pump casing when:

1. The pump is being put into service for the first time.
2. The pump has not been used for a considerable length of time.
3. The liquid in the pump casing has evaporated.

Once the pump casing has been filled, the pump will prime as necessary.



After filling the pump casing, reinstall and tighten the fill plug. Do not attempt to operate the pump unless all connecting piping is securely installed. Otherwise, liquid in the pump forced out under pressure could cause injury to personnel.

To fill the pump, remove the pump casing fill cover or fill plug at the top of the casing and add clean liquid until the pump is filled. Replace the fill cover or fill plug before operating the pump.

### NOTE

*This pump is self-priming; however, it is **not** suited for unattended reprime applications. In the event of suction check valve failure and loss of prime, the pump casing **must** be refilled through the fill cover or fill plug.*

### STARTING

Consult the operations manual furnished with the engine.

### OPERATION

#### Lines With a Bypass

Close the discharge throttling valve (if so equipped) so that the pump will not have to prime against the weight of the liquid in the discharge line. Air from the suction line will be discharged through the bypass line back to the wet well during

the priming cycle. When the pump is fully primed and liquid is flowing steadily from the bypass line, open the discharge throttling valve. Liquid will then continue to circulate through the bypass line while the pump is in operation.

### Lines Without a Bypass

Open all valves in the discharge line and start the engine. Priming is indicated by a positive reading on the discharge pressure gauge or by a quieter operation. The pump may not prime immediately because the suction line must first fill with liquid. If the pump fails to prime within five minutes, stop it and check the suction line for leaks.

After the pump has been primed, partially close the discharge line throttling valve in order to fill the line slowly and guard against excessive shock pressure which could damage pipe ends, gaskets, sprinkler heads, and any other fixtures connected to the line. When the discharge line is completely filled, adjust the throttling valve to the required flow rate.

### Leakage

No leakage should be visible at pump mating surfaces, or at pump connections or fittings. Keep all line connections and fittings tight to maintain maximum pump efficiency.

### Liquid Temperature And Overheating

The **maximum** liquid temperature for this pump is 110° F (43° C). Do not apply it at a higher operating temperature.

Overheating can occur if operated with the valves in the suction or discharge lines closed. Operating against closed valves could bring the liquid to a boil, build pressure, and cause the pump to rupture or explode. If overheating occurs, stop the pump and allow it to cool before servicing it. Refill the pump casing with cool liquid.



**Allow an over-heated pump to completely cool before servicing. Do not re-**

**move plates, covers, gauges, or fittings from an over-heated pump. Liquid within the pump can reach boiling temperatures, and vapor pressure within the pump can cause parts being disengaged to be ejected with great force. After the pump cools, drain the liquid from the pump by removing the casing drain plug. Use caution when removing the plug to prevent injury to personnel from hot liquid.**

### Strainer Check

If a suction strainer has been shipped with the pump or installed by the user, check the strainer regularly, and clean it as necessary. The strainer should also be checked if pump flow rate begins to drop. If a vacuum suction gauge has been installed, monitor and record the readings regularly to detect strainer blockage.

**Never** introduce air or steam pressure into the pump casing or piping to remove a blockage. This could result in personal injury or damage to the equipment. If backflushing is absolutely necessary, liquid pressure **must** be limited to 50% of the maximum permissible operating pressure shown on the pump performance curve (see Section E, Page 1). If the pump is fitted with a Gorman-Rupp double grease lubricated seal, the maximum incoming pressure must be reduced to 10 p.s.i.

### Pump Vacuum Check

With the pump inoperative, install a vacuum gauge in the system, using pipe dope on the threads. Block the suction line and start the pump. At operating speed the pump should pull a vacuum of 20 inches (508,0 mm) or more of mercury. If it does not, check for air leaks in the seal, gasket, or discharge valve.

Open the suction line, and read the vacuum gauge with the pump primed and at operation speed. Shut off the pump. The vacuum gauge reading will immediately drop proportionate to static suction lift, and should then stabilize. If the vacuum reading falls off rapidly after stabilization, an air leak exists. Before checking for the source of the leak, check the point of installation of the vacuum gauge.



## STOPPING

Never halt the flow of liquid suddenly. If the liquid being pumped is stopped abruptly, damaging shock waves can be transmitted to the pump and piping system. Close all connecting valves slowly.

On engine driven pumps, reduce the throttle speed slowly and allow the engine to idle briefly before stopping.

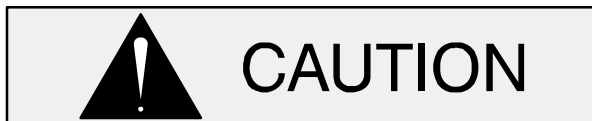

If the application involves a high discharge head, gradually close the discharge throttling valve before stopping the pump.

After stopping the pump, remove the engine ignition key to ensure that the pump will remain inoperative.

### Cold Weather Preservation

In below freezing conditions, drain the pump to prevent damage from freezing. Also, clean out any solids by flushing with a hose. Operate the pump for approximately one minute; this will remove any remaining liquid that could freeze the pump rotating parts. If the pump will be idle for more than a few hours, or if it has been pumping liquids containing a large amount of solids, drain the pump, and flush it thoroughly with clean water. To prevent

large solids from clogging the drain port and preventing the pump from completely draining, insert a rod or stiff wire in the drain port, and agitate the liquid during the draining process. Clean out any remaining solids by flushing with a hose.

## BEARING TEMPERATURE CHECK

Bearings normally run at higher than ambient temperatures because of heat generated by friction. Temperatures up to 160°F (71°C) are considered normal for bearings, and they can operate safely to at least 180°F (82°C).

Checking bearing temperatures by hand is inaccurate. Bearing temperatures can be measured accurately by placing a contact-type thermometer against the housing. Record this temperature for future reference.

A sudden increase in bearing temperature is a warning that the bearings are at the point of failing to operate properly. Make certain that the bearing lubricant is of the proper viscosity and at the correct level (see **LUBRICATION** in **MAINTENANCE AND REPAIR**). Bearing overheating can also be caused by shaft misalignment and/or excessive vibration.

When pumps are first started, the bearings may seem to run at temperatures above normal. Continued operation should bring the temperatures down to normal levels.

## TROUBLESHOOTING – SECTION D

Review all SAFETY information in Section A.



**Before attempting to open or service the pump:**

1. Familiarize yourself with this manual.
2. Switch off the engine ignition and disconnect the positive battery cable to ensure that the pump will remain inoperative.
3. Allow the pump to completely cool if overheated.
4. Check the temperature before opening any covers, plates, or plugs.
5. Close the suction and discharge valves.
6. Vent the pump slowly and cautiously.
7. Drain the pump.

TROUBLE	POSSIBLE CAUSE	PROBABLE REMEDY
PUMP FAILS TO PRIME	Not enough liquid in casing. Suction check valve contaminated or damaged. Air leak in suction line. Lining of suction hose collapsed. Leaking or worn seal or pump gasket. Suction lift or discharge head too high. Strainer clogged. Suction check valve or foot valve clogged or binding.	Add liquid to casing. See <b>PRIMING</b> . Clean or replace check valve. Correct leak. Replace suction hose. Check pump vacuum. Replace leaking or worn seal or gasket. Check piping installation and install bypass line if needed. See <b>INSTALLATION</b> . Check strainer and clean if necessary. Clean valve
PUMP STOPS OR FAILS TO DELIVER RATED FLOW OR PRESSURE	Air leak in suction line. Lining of suction hose collapsed. Leaking or worn seal or pump gasket. Strainer clogged.	Correct leak. Replace suction hose. Check pump vacuum. Replace leaking or worn seal or gasket. Check strainer and clean if necessary.

TROUBLE	POSSIBLE CAUSE	PROBABLE REMEDY
<p>PUMP STOPS OR FAILS TO DELIVER RATED FLOW OR PRESSURE (CONT'D)</p>	<p>Suction intake not submerged at proper level or sump too small.</p> <p>Impeller or other wearing parts worn or damaged.</p> <p>Impeller clogged.</p> <p>Pump speed too slow.</p> <p>Suction lift or discharge head too high.</p>	<p>Check installation and correct submergence as needed.</p> <p>Replace worn or damaged parts. Check that impeller is properly centered and rotates freely.</p> <p>Free impeller of debris.</p> <p>Check engine output; consult engine operation manual.</p> <p>Check piping installation and install bypass line if needed. See <b>INSTALLATION</b>.</p>
<p>PUMP REQUIRES TOO MUCH POWER</p>	<p>Pump speed too high.</p> <p>Discharge head too low.</p> <p>Liquid solution too thick.</p> <p>Bearing(s) frozen.</p>	<p>Check engine output.</p> <p>Adjust discharge valve.</p> <p>Dilute if possible.</p> <p>Disassemble pump and check bearing(s).</p>
<p>PUMP CLOGS FREQUENTLY</p>	<p>Liquid solution too thick.</p> <p>Discharge flow too slow.</p> <p>Suction check valve or foot valve clogged or binding.</p>	<p>Dilute if possible.</p> <p>Open discharge valve fully to increase flow rate, and run power source at maximum governed speed.</p> <p>Clean valve.</p>
<p>EXCESSIVE NOISE</p>	<p>Cavitation in pump.</p> <p>Pumping entrained air.</p> <p>Pump or drive not securely mounted.</p> <p>Impeller clogged or damaged.</p>	<p>Reduce suction lift and/or friction losses in suction line. Record vacuum and pressure gauge readings and consult local representative or factory.</p> <p>Locate and eliminate source of air bubble.</p> <p>Secure mounting hardware.</p> <p>Clean out debris; replace damaged parts.</p>
<p>BEARINGS RUN TOO HOT</p>	<p>Bearing temperature is high, but within limits.</p> <p>Low or incorrect lubricant.</p> <p>Suction and discharge lines not properly supported.</p> <p>Drive misaligned.</p>	<p>Check bearing temperature regularly to monitor any increase.</p> <p>Check for proper type and level of lubricant.</p> <p>Check piping installation for proper support.</p> <p>Align drive properly.</p>

### PREVENTIVE MAINTENANCE

Since pump applications are seldom identical, and pump wear is directly affected by such things as the abrasive qualities, pressure and temperature of the liquid being pumped, this section is intended only to provide general recommendations and practices for preventive maintenance. Regardless of the application however, following a routine preventive maintenance schedule will help assure trouble-free performance and long life from your Gorman-Rupp pump. For specific questions concerning your application, contact your Gorman-Rupp distributor or the Gorman-Rupp Company.

Record keeping is an essential component of a good preventive maintenance program. Changes in suction and discharge gauge readings (if so

equipped) between regularly scheduled inspections can indicate problems that can be corrected before system damage or catastrophic failure occurs. The appearance of wearing parts should also be documented at each inspection for comparison as well. Also, if records indicate that a certain part (such as the seal) fails at approximately the same duty cycle, the part can be checked and replaced before failure occurs, reducing unscheduled down time.

For new applications, a first inspection of wearing parts at 250 hours will give insight into the wear rate for your particular application. Subsequent inspections should be performed at the intervals shown on the chart below. Critical applications should be inspected more frequently.

<b>Preventive Maintenance Schedule</b>					
<b>Item</b>	<b>Service Interval*</b>				
	<b>Daily</b>	<b>Weekly</b>	<b>Monthly</b>	<b>Semi-Annually</b>	<b>Annually</b>
General Condition (Temperature, Unusual Noises or Vibrations, Cracks, Leaks, Loose Hardware, Etc.)	I				
Pump Performance (Gauges, Speed, Flow)	I				
Bearing Lubrication		I			R
Seal Lubrication (And Packing Adjustment, If So Equipped)		I			R
V-Belts (If So Equipped)			I		
Air Release Valve Plunger Rod (If So Equipped)			I	C	
Front Impeller Clearance (Wear Plate)				I	
Rear Impeller Clearance (Seal Plate)				I	
Check Valve					I
Pressure Relief Valve (If So Equipped)					C
Pump and Driver Alignment					I
Shaft Deflection					I
Bearings					I
Bearing Housing					I
Piping					I
Driver Lubrication – See Mfgr’s Literature					I

Legend:  
 I = Inspect, Clean, Adjust, Repair or Replace as Necessary  
 C = Clean  
 R = Replace

\* Service interval based on an intermittent duty cycle equal to approximately 4000 hours annually. Adjust schedule as required for lower or higher duty cycles or extreme operating conditions.

## PUMP MAINTENANCE AND REPAIR – SECTION E

MAINTENANCE AND REPAIR OF THE WEARING PARTS OF THE PUMP WILL MAINTAIN PEAK OPERATING PERFORMANCE.

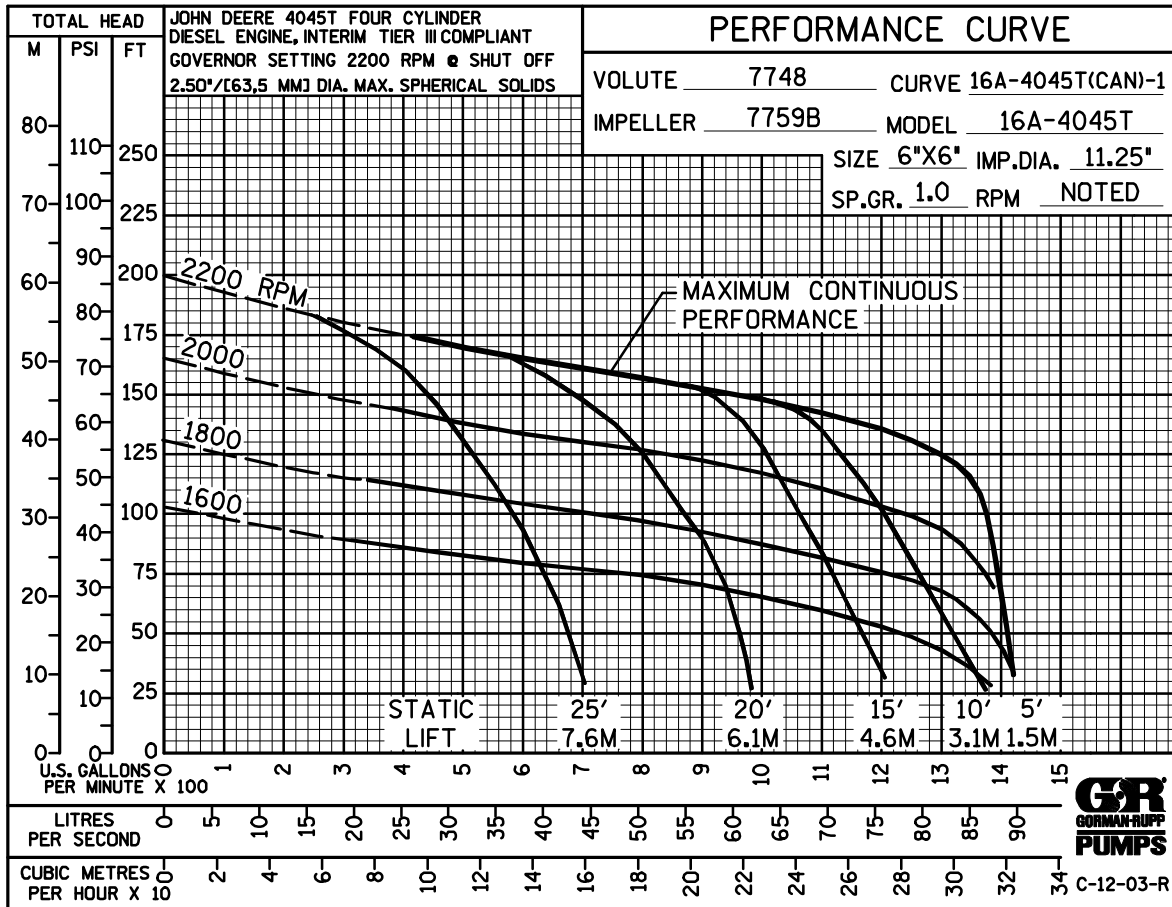

**\* STANDARD PERFORMANCE FOR PUMP MODEL 16A2-4045T**

\* Based on 70°F (21°C) clear water at sea level with minimum suction lift. Since pump installations are seldom identical, your performance may be different due to such factors as viscosity, specific gravity, elevation, temperature, and impeller trim.

Contact the Gorman-Rupp Company to verify performance or part numbers.

If your pump serial number is followed by an "N", your pump is **NOT** a standard production model.



Pump speed and operating condition points must be within the continuous performance range shown on the curve.

ILLUSTRATION

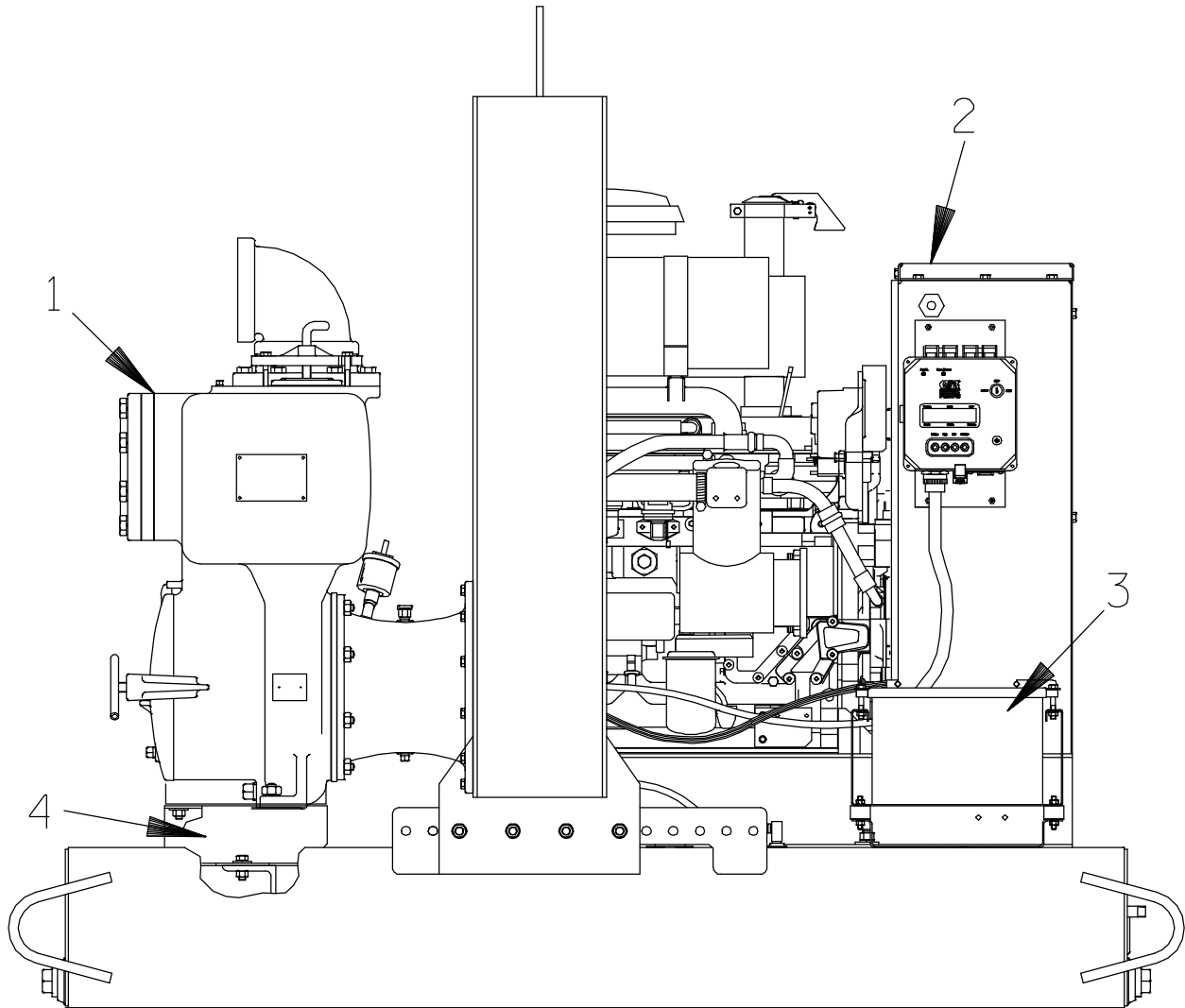

Figure 1. Pump Model 16A2-4045T

**PARTS LIST**  
**Pump Model 16A2-4045T**  
 (From S/N Up)

If your pump serial number is followed by an "N", your pump is **NOT** a standard production model. Contact the Gorman-Rupp Company to verify part numbers.

ITEM NO.	PART NAME	PART NUMBER	MAT'L CODE	QTY
1	PUMP END ASSY	16A2-(SAE 4/10)	---	1
2	J.D. 4045T POWER UNIT	46143-153	---	1
3	BATTERY	SEE OPTIONS	---	REF
4	PUMP MOUNTING KIT	48157-063	---	1
NOT SHOWN:				
	G-R DECAL	GR-06	---	1
	ENGINE STARTUP TAG	38816-269	---	1
OPTIONAL:				
	BATTERY	29331-527	---	1

ILLUSTRATION

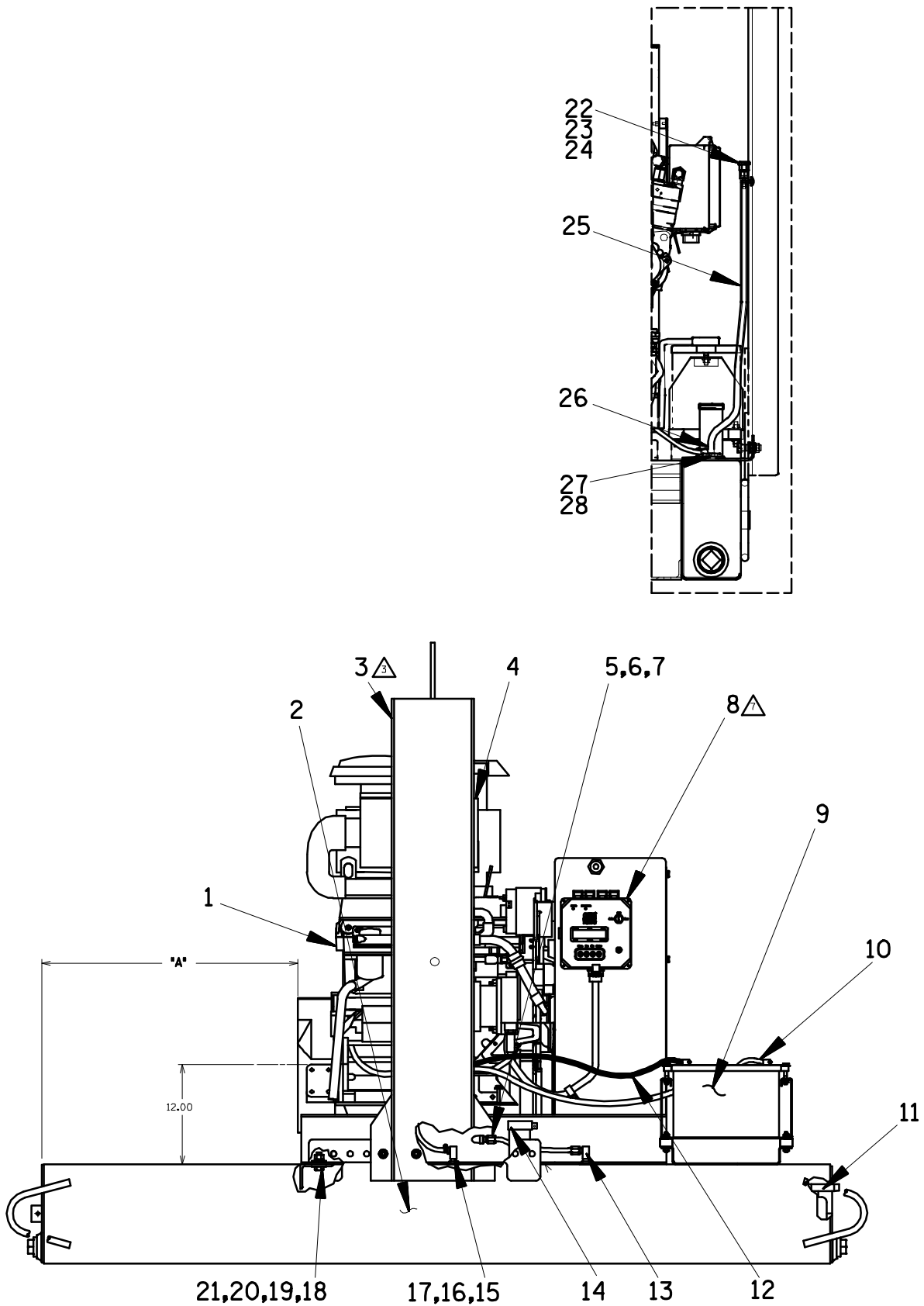

Figure 2. 46143-153 Power Unit Kit



**PARTS LIST**  
**46143-153 Power Unit Kit**

ITEM NO.	PART NAME	PART NUMBER	MAT'L CODE	QTY
1	JOHN DEERE ENGINE	29224-302	----	1
2	BASE/FUEL TANK	41553-029	24150	1
3	LIFTING BAIL KIT	48274-804	----	1
4	MUFFLER GUARD ASSEMBLY	42331-061	----	1
5	MALE ELBOW	26351-131	----	1
6	CONNECTOR	S1447	----	2
7	HOSE ASSEMBLY	46341-789	----	1
8	CONTROL PANEL	48122-552	----	1
9	BATTERY BOX KIT	42432-005	----	1
10	NEG BATTERY CABLE	47311-142	----	1
11	OIL DRAIN ASSEMBLY	46342-031	----	1
12	POSITIVE CABLE ASSEMBLY	47311-108	----	1
13	FUEL PICKUP/RETURN	29332-145	----	2
14	FUEL TANK CAP	29332-111	----	1
15	HOSE BARB FITTING	26523-386	----	2
16	HOSE	11308G	----	1
17	HOSE CLAMP	26518-641	----	2
18	HEX HD CAPSCREW	B1007	15991	4
19	HEX NUT	D10	15991	4
20	LOCKWASHER	J10	15991	4
21	FLAT WASHER	K10	15991	4
22	AIR VENT	S1703	----	1
23	HOSE BARB FITTING	26523-447	----	1
24	CABLE TIE	27111-218	----	1
25	HOSE	18513-302	----	1
26	HOSE BARB FITTING	26523-389	----	1
27	MECH FUEL GAUGE ASSY	29332-173	----	1
28	SOC HD MACH SCREW	BD#10-03S	15991	5

## NOT SHOWN:

ENGINE STARTUP TAG	38816-269	----	1
FUEL DECAL	38816-196	----	1

## OPTIONAL:

WHEEL KIT	GRP30-262	----	1
-----------	-----------	------	---

ILLUSTRATION

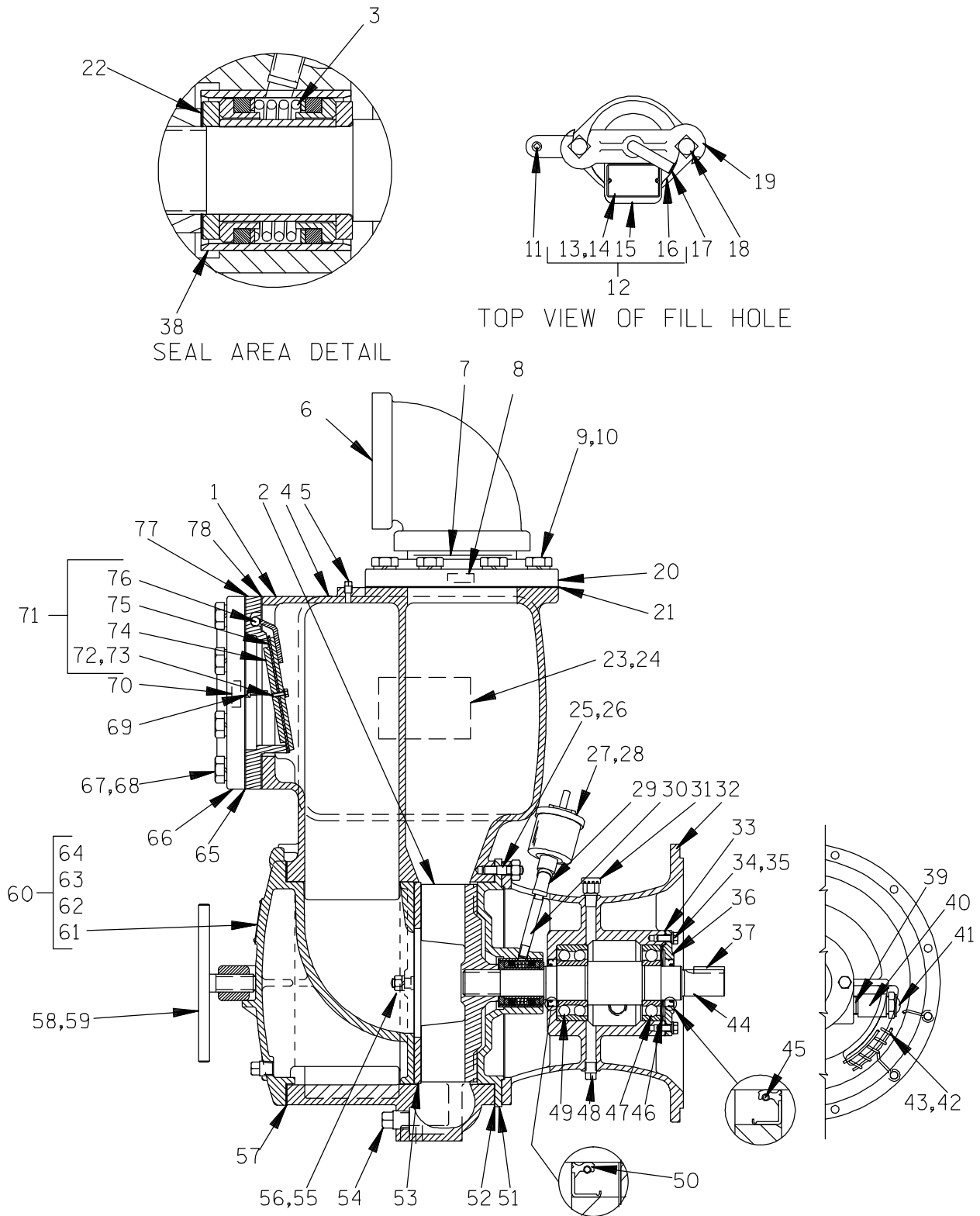

Figure 3. 16A2-(SAE4/10) Pump End Assy

**PARTS LIST**  
**16A2--(SAE4/10) Pump End Assy**

ITEM NO.	PART NAME	PART NUMBER	MAT'L CODE	QTY	ITEM NO.	PART NAME	PART NUMBER	MAT'L CODE	QTY
1	PUMP CASING	7748	10010	1	45 *	OIL SEAL	25258-622	----	1
2 *	IMPELLER	7759B	11000	1	46	WAVY WASHER	23963-327	----	1
3 *	SEAL ASSY	GS1500	----	1	47 *	BALL BEARING	S1077	----	1
4	PRIMING STICKER	6588AH	----	1	48	INTERM DRAIN PLUG	P06	15079	1
5	PIPE PLUG	P04	15079	1	49 *	BALL BEARING	23421-461	----	1
6	DISCHARGE ELBOW	R96	11990	1	50 *	OIL SEAL	25258-622	----	1
7	DISCHARGE NIPPLE	T96	15079	1	51	SEAL PLATE ASSY	11895A	10010	1
8	DISCHARGE STICKER	6588BJ	----	1	52 *	CASING GASKET SET	34G	18000	1
9	HEX HD CAPSCREW	B1208	15991	8	53 *	WEAR PLATE ASSY	2545	15990	1
10	LOCKWASHER	J12	15991	8	54	CASING DRAIN PLUG	P16	10009	1
11	PIPE PLUG	P04	15079	1	55	HEX NUT	D08	15991	2
12	FILL CVR PLATE ASSY	42111-344	----	1	56	LOCKWASHER	J08	15991	2
13	-WARNING PLATE	38816-097	13990	1	57 *	BACK COVER GASKET	7668G	20000	1
14	-DRIVE SCREW	BM#04-03	17000	2	58	CLAMP BAR SCREW	2536	24000	1
15	-COVER PLATE	NOT AVAILABLE		1	59	CLAMP BAR	2547	11010	1
16 *	-FILL COVER GASKET	50G	19210	1	60	BACK CVR PLATE ASSY	42111-932	----	1
17	CLAMP BAR SCREW	31912-009	15000	1	61	-WARNING PLATE	2613EV	13990	1
18	MACHINE BOLT	A1014	15991	2	62	-DRIVE SCREW	BM#04-03	15990	4
19	CLAMP BAR	38111-004	11010	1	63	-BACK COVER PLATE	NOT AVAILABLE		1
20	DISCHARGE FLANGE	1758	10010	1	64	-DRAIN PLUG	P08	15079	1
21 *	DISCH FLANGE GASKET	1679G	18000	1	65 *	SUCT FLANGE GASKET	1679G	18000	1
22 *	IMP ADJ SHIM SET	5091	17090	REF	66	SUCTION FLANGE	1758	10010	1
23	NAME PLATE	38818-023	13990	1	67	HEX HD CAPSCREW	B1212	15991	8
24	DRIVE SCREW	BM#04-03	17000	4	68	LOCKWASHER	J12	15991	8
25	STUD	C0809	15991	8	69	RD HD CAPSCREW	X0404	17090	2
26	HEX NUT	D08	15991	8	70	SUCTION STICKER	6588AG	----	1
27	GREASE CUP	S1509	----	1	71	SUCT CHK VLV ASSY	7265	----	1
28	GRS CUP INSTR STKR	6588BD	----	1	72	-HEX HD CAPSCREW	B0403	17000	2
29	PIPE ELBOW	AG04	11999	1	73	-LOCKWASHER	J04	17090	2
30	HEAVY PIPE NIPPLE	THA0416	15079	1	74	-VALVE WEIGHT	7263	15990	1
31	AIR VENT	S1703	----	1	75 *	-CHECK VLV GASKET	7264	19070	1
32	INTERMEDIATE	38263-614	10010	1	76	-VALVE WEIGHT	7262	24000	1
33 *	BEARING CAP GASKET	5413G	18000	1	77	CHECK VALVE SEAT	7261	10010	1
34	HEX HD CAPSCREW	B0604	15991	4	78 *	CHK VLV SEAT GASKET	7261G	18000	1
35	LOCKWASHER	J06	15991	4					
36	BEARING CAP	4185A	10010	1					
37 *	SHAFT KEY	N0607	15990	1					
38 *	SEAL LINER	7408	14010	REF	NOT SHOWN:				
39	PIPE NIPPLE	T12	15079	1		STRAINER	7823	24000	1
40	PIPE COUPLING	AE12	15079	1		DRIVE ASSY	44162-119	----	1
41	SIGHT GAUGE	S1471	----	1		INSTRUCTION TAG	38817-085	----	1
42	INTERMEDIATE GUARD	42381-031	24152	1		LUBE DECAL	38816-079	----	1
43	INTERMEDIATE GUARD	42381-032	24152	1		G-R DECAL	GR-03	----	1
44 *	IMPELLER SHAFT	38514-807	16040	1		INSTRUCTION DECAL	2613DK	----	1
						WARNING DECAL	2613FE	----	1

\* INDICATES PARTS RECOMMENDED FOR STOCK

ILLUSTRATION

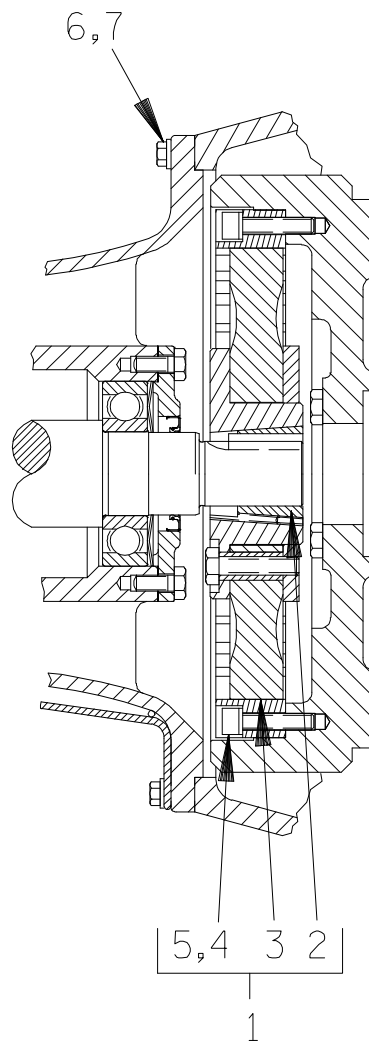











Figure 4. 44162-119 Drive Assembly  
PARTS LIST

ITEM NO.	PART NAME	PART NUMBER	MAT'L CODE	QTY
1	COUPLING KIT	48112-001	---	1
2	-BUSHING	24131-345	---	1
3	-COUPLING ASSEMBLY	44165-011	---	1
4	 -LOCKWASHER	J06	15991	8
4	 -LOCKWASHER	21171-536	---	8
5	 -SOCKET HD CAPSCREW	BD0606-1/2	15991	8
5	 -SOCKET HD CAPSCREW	22644-220	---	8
6	 HEX HD CAPSCREW	B0605	15991	12
6	 HEX HD CAPSCREW	22645-164	---	12
7	 LOCKWASHER	J06	15991	12
7	 LOCKWASHER	21171-511	---	12
	 USE FOR SAE APPLICATIONS			
	 USE FOR METRIC APPLICATIONS			

## PUMP AND SEAL DISASSEMBLY AND REASSEMBLY

Review all **SAFETY** information in Section A.

Follow the instructions on all tags, label and decals attached to the pump.

This pump requires little service due to its rugged, minimum-maintenance design. However, if it becomes necessary to inspect or replace the wearing parts, follow these instructions which are keyed to the illustrations (see Figures 1 through 4) and the accompanying parts lists.

This manual will alert personnel to known procedures which require special attention, to those which could damage equipment, and to those which could be dangerous to personnel. However, this manual cannot possibly anticipate and provide detailed precautions for every situation that might occur during maintenance of the unit. Therefore, it is the responsibility of the owner/maintenance personnel to ensure that **only** safe, established maintenance procedures are used, and that any procedures not addressed in this manual are performed **only** after establishing that neither personal safety nor pump integrity are compromised by such practices.

Most service functions, such as wear plate, impeller, and seal replacement, may be performed by draining the pump and removing the back cover assembly. However, the following instructions assume complete disassembly is required.

Before attempting to service the pump, switch off the engine ignition and remove the key to ensure that it will remain inoperative. Close all valves in the suction and discharge lines.

For engine disassembly and repair, consult the literature supplied with the engine, or contact your local John Deere engine representative.



Before attempting to open or service the pump:

1. Familiarize yourself with this manual.
2. Switch off the engine ignition and disconnect the positive battery cable to ensure that the pump will remain inoperative.
3. Allow the pump to completely cool if overheated.
4. Check the temperature before opening any covers, plates, or plugs.
5. Close the suction and discharge valves.
6. Vent the pump slowly and cautiously.
7. Drain the pump.



Use lifting and moving equipment in good repair and with adequate capacity to prevent injuries to personnel or damage to equipment. The bail is intended for use in lifting the pump assembly only. Suction and discharge hoses and piping must be removed from the pump before lifting.

### Back Cover Removal

(Figure 3)

Before attempting to service the pump, remove the pump casing drain plug (54) and drain the pump. Clean and reinstall the drain plug. The wear plate (53) and check valve (71) are easily accessible and may be serviced by removing the back cover assembly (60).

Remove the cover clamp screw (58) and clamp bar (59) securing the back cover. Pull the back cover and assembled wear plate from the pump casing (1). Inspect the back cover gasket (57) and replace it if damaged or worn.

Inspect the wear plate and replace it if badly scored or worn. To remove the wear plate, disengage the hardware (55 and 56).

### Suction Check Valve Removal

#### (Figure 3)

The check valve assembly (71) may be serviced by removing the suction flange (4). To remove the flange, disconnect the suction piping. Disengage the hardware (67 and 68) and separate the suction flange from the check valve seat (65). Remove the machine screws (69), and pull the seat and assembled check valve from the suction port. Pull the check valve out of the seat.

Inspect the check valve components for wear or damage. If replacement is required, disengage the hardware (72 and 73) and separate the valve weights (74 and 76) and gasket (75).

Replace the flange gaskets (77 and 78) as required.

### Pump Casing Removal

#### (Figure 3)

To service the impeller or seal assembly, disconnect the discharge piping. Remove the hardware securing the casing (1) to the base.

Remove the nuts (26) securing the pump casing (1) to the seal plate (51) and intermediate (32). Install a standard 5/8-11 UNC-2B lifting eye in the tapped hole in the top of the pump casing. **Be sure** to screw the eye into the casing until fully engaged. Use a hoist and sling of suitable capacity to separate the casing from the seal plate and intermediate.



**Do not attempt to lift the complete pump unit using the lifting eye. It is designed to facilitate removal or installation of individual components only. Additional weight may result in damage to the pump or failure of the eye bolt.**

Remove any leveling shims used under the casing mounting feet. Tie and tag the shims for ease of reassembly.

### Impeller Removal

#### (Figure 3)

Turn the cross arm on the automatic lubricating grease cup (27) clockwise until it rests against the cover (see Figure 6). This will prevent the grease from escaping when the impeller is removed.

To remove the impeller (2), tap the vanes in counterclockwise direction (when facing the impeller) with a block of wood or soft-faced mallet. **Be careful** not to damage the impeller. When the impeller breaks loose, unscrew it from the shaft. Use caution when removing the impeller; tension on the shaft seal spring will be released as the impeller is unscrewed. Inspect the impeller and replace if cracked or badly worn.

Slide the impeller adjusting shims (22) off the impeller shaft (44). Tie and tag the shims or measure and record their thickness for ease of reassembly.

### Seal Removal and Disassembly

#### (Figure 3)

To remove the seal assembly (3), remove the grease cup and piping (27, 28, 29 and 30). Slide the seal plate and seal parts off the shaft as a single unit. **Be careful** not to drop or damage any seal parts.

Carefully remove the stationary and rotating seal elements, packing rings, seal spring, and shaft sleeve from the seal plate.

#### NOTE

*The seal assembly may be removed without completely disassembling the pump by removing the impeller through the back cover opening and using a pair of stiff wires with hooked ends to pull the seal parts out of the seal plate.*

Inspect the seal liner (38) for wear or grooves which could cause leakage or damage to the seal packing rings. The seal liner is a press fit in the seal plate, and does not normally require replacement. If replacement is necessary, see **Seal Installation**.

If no further disassembly is required, refer to **Seal Reassembly And Installation**.

### Separating Intermediate And Drive Assembly From Engine

#### (Figure 4)

If it is necessary to separate the intermediate and drive assemblies from the engine, support the intermediate using a hoist and sling, and remove the hardware (6 and 7) securing the intermediate to the engine bellhousing. Remove the intermediate guards (42 and 43, Figure 3) and separate the assemblies by pulling the intermediate straight away from the engine.

As the assemblies separate, the flexible portion of the coupling assembly (3) will remain on the shaft. To remove the coupling from the shaft, unscrew the two allen head setscrews from the bushing (2). Screw one of the setscrews into the puller hole on the circumference of the bushing. As the coupling and bushing separate, remove the bushing, and slide the coupling off the shaft. Remove the shaft key (37, Figure 3).

It is not necessary to remove the outer ring of the coupling from the engine flywheel unless the coupling must be replaced. To remove the ring, disengage the hardware (4 and 5) securing it to the flywheel.

### Shaft and Bearing Removal and Disassembly

#### (Figure 3)

When the pump is properly operated and maintained, the bearing housing should not require disassembly. Disassemble the shaft and bearings **only** when there is evidence of wear or damage.



Shaft and bearing disassembly in the field is not recommended. These operations should be performed only in a properly-equipped shop by qualified personnel.

Remove the intermediate drain plug (48) and drain the lubricant. Clean and reinstall the drain plug.

Disengage the hardware (34 and 35) and remove the bearing cap (36), gasket (33), outboard oil seal (45), and wavy washer (46). Press the oil seal from the bearing cap.

Place a block of wood against the impeller end of the shaft (44), and tap the shaft and assembled bearings from the intermediate. Press the inboard oil seal (50) from the intermediate.

After removing the shaft and bearings, clean and inspect the bearings **in place** as follows.



To prevent damage during removal from the shaft, it is recommended that bearings be cleaned and inspected **in place**. It is **strongly** recommended that the bearings be replaced **any** time the shaft and bearings are removed.

Clean the intermediate, shaft and all component parts (except the bearings) with a soft cloth soaked in cleaning solvent. Inspect the parts for wear or damage and replace as necessary.



**Most cleaning solvents are toxic and flammable. Use them only in a well ventilated area free from excessive heat, sparks, and flame. Read and follow all precautions printed on solvent containers.**

Clean the bearings thoroughly in **fresh** cleaning solvent. Dry the bearings with filtered compressed air and coat with light oil.



Bearings must be kept free of all dirt and foreign material. Failure to do so will greatly shorten bearing life. **Do not** spin dry bearings. This may scratch the balls or races and cause premature bearing failure.

Rotate the bearings by hand to check for roughness or binding and inspect the bearing balls. If ro-

tation is rough or the bearing balls are discolored, replace the bearings.

The bearing tolerances provide a tight press fit onto the shaft and a snug slip fit into the bearing housing. Replace the bearings, shaft, or intermediate if the proper bearing fit is not achieved.

If bearing replacement is required, use a bearing puller to remove the inboard and outboard bearings (47 and 49) from the shaft.

### Shaft and Bearing Reassembly and Installation

#### (Figure 3)

Inspect the shaft for distortion, nicks or scratches, or for thread damage on the impeller end. Dress small nicks and burrs with a fine file or emery cloth. Replace the shaft if defective.

Position the inboard oil seal (50) in the intermediate housing bore with the lip positioned as shown in Figure 3. Press the oil seal into the housing until the face is **just flush** with the machined surface on the housing.

Clean and inspect the bearings as indicated in **Shaft And Bearing Removal And Disassembly**.



To prevent damage during removal from

the shaft, it is recommended that bearings be cleaned and inspected **in place**. It is **strongly** recommended that the bearings be replaced **any** time the shaft and bearings are removed.

The bearings may be heated to ease installation. An induction heater, hot oil bath, electric oven, or hot plate may be used to heat the bearings. Bearings should **never** be heated with a direct flame or directly on a hot plate.

#### NOTE

*If a hot oil bath is used to heat the bearings, both the oil and the container must be **absolutely clean**. If the oil has been previously used, it must be **thoroughly filtered**.*

Heat the bearings to a uniform temperature **no higher than 250°F (120°C)**, and slide the bearings onto the shaft, one at a time, until they are fully seated. This should be done quickly, in one continuous motion, to prevent the bearings from cooling and sticking on the shaft.

#### NOTE

*Position the inboard bearing (49) on the shaft as indicated in Figure 5.*

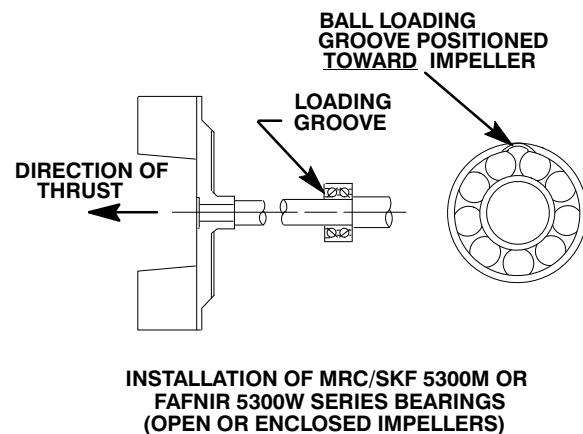
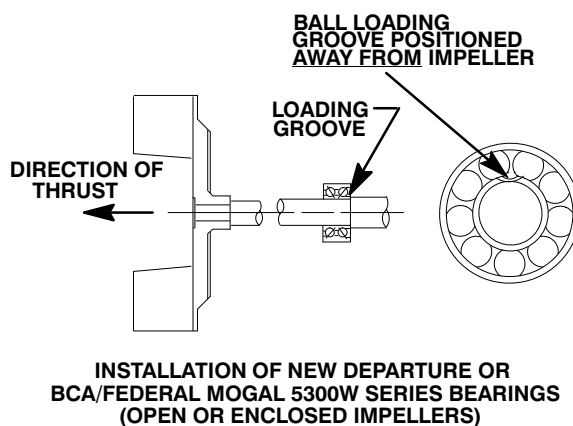

**Figure 5. Inboard Bearing Positioning**

After the bearings have been installed and allowed to cool, check to ensure that they have not moved away from the shaft shoulders in shrinking. If

movement has occurred, use a suitable sized sleeve and a press to reposition the bearings against the shaft shoulders.



If heating the bearings is not practical, use a suitable sized sleeve, and an arbor (or hydraulic) press to install the bearings on the shaft.

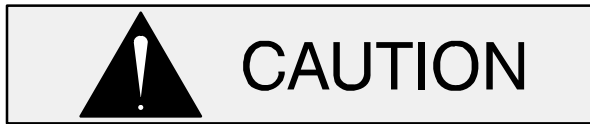

When installing the bearings onto the shaft, **never** press or hit against the outer race, balls, or ball cage. Press **only** on the inner race.

Slide the shaft and assembled bearings into the intermediate bore until the inboard bearing is fully seated against the bore shoulder. **Be careful** not to damage the lip of the oil seal (50) on the shaft threads.

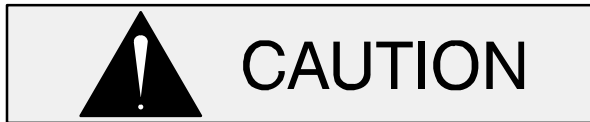

When installing the shaft and bearings into the bearing bore, push against the outer race. **Never** hit the balls or ball cage.

Apply a light coating of oil to the lip of the outboard oil seal (45), and press it into the bearing cap (36) with the lip positioned as shown in Figure 3. The face of the oil seal should be **just flush** with the outer face of the bearing cap.

Install the wavy washer (46) and bearing cap gasket (33), and secure the bearing cap to the intermediate with the hardware (34 and 35). **Be careful** not to damage the lip of the oil seal (45) on the shaft keyway.

Lubricate the bearings as indicated in **LUBRICATION** at the end of this section.

### Securing Intermediate And Drive Assembly To Engine

#### (Figure 4)

Install the shaft key (37, Figure 3) in the shaft keyway. Position the flexible portion of the coupling assembly (3) on the shaft as shown in Figure 4.

#### NOTE

*The flexible portion of the coupling must be properly positioned on the shaft. The heads of the caps-*

*crews in the center of the coupling **must be positioned toward the pump end of the shaft.***

Align the keyway in the bushing (2) with the shaft key, and slide it onto the shaft until it is **just flush** with the end of the shaft. Rotate the flexible portion of the coupling until the tapped holes for the two setscrews align with those in the bushing, and install the setscrews.

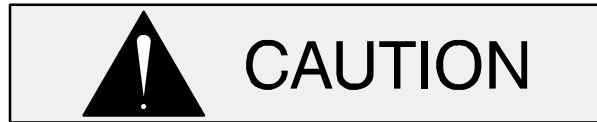

Make certain that the flexible portion of the coupling is mounted as shown in Figure 4. **This is critical.** If the coupling is not properly positioned on the shaft, the coupling parts may not fully engage, or a pre-load condition can cause premature bearing failure.

The end of the shaft must be **just flush** with the face of the bushing. This will allow the two portions of the coupling to fully engage when the intermediate is secured to the engine bellhousing, without pre-loading the bearings.

With the flexible portion of the coupling and the bushing properly positioned on the shaft, tighten the two setscrews in an alternating sequence until the bushing and coupling are fully secured. Torque the setscrews to 14.6 ft. lbs. (175 in. lbs. or 2 m. kg.).

If the complete coupling assembly is being replaced, apply 'Loctite Retaining Compound No. 242' or equivalent to the threads of the hardware (4 and 5), and secure the outer ring of the coupling to the engine flywheel by torquing the hardware to 45 ft. lbs. (540 in. lbs. or 6,2 m. kg.).

Using a suitable lifting device, position the assembled coupling, intermediate, shaft and bearings so the flexible portion of the coupling seats inside the outer ring attached to the engine flywheel.

#### NOTE

*To ease installation, **lightly** lubricate the rubber portion of the coupling with a **non-petroleum based lubricant** such as vegetable oil or glycerin, or a silicon-based lubricant such as "WD40" or equivalent.*

**Do not** use petroleum-based lubricants, or any other substance which may soften or otherwise damage the rubber.

---

Install the intermediate guards (42 and 43, Figure 3) and secure the intermediate to the engine bell-housing with the previously removed hardware (6 and 7).

### Seal Reassembly and Installation

(Figures 3 and 6)

Clean the seal cavity and shaft with a cloth soaked in fresh cleaning solvent.



**Most cleaning solvents are toxic and flammable. Use them only in a well-ventilated area free from excessive heat, sparks, and flame. Read and follow all precautions printed on solvent containers.**

The seal is not normally reused because wear patterns on the finished faces cannot be realigned during reassembly. This could result in premature failure. If necessary to reuse an old seal in an emergency, **carefully** wash all metallic parts in **fresh** cleaning solvent and allow to dry thoroughly.

Handle the seal parts with extreme care to prevent damage. Be careful not to contaminate precision finished faces; even fingerprints on the faces can shorten seal life. If necessary, clean the faces with a non-oil based solvent and a clean, lint-free tissue. Wipe **lightly** in a concentric pattern to avoid scratching the faces.

Inspect the seal components for wear, scoring, grooves, and other damage that might cause leakage. If any components are worn, replace the complete seal; **never mix old and new seal parts.**

If a replacement seal is being used, remove it from the container and inspect the precision finished faces to ensure that they are free of any foreign matter.

To ease installation of the seal, lubricate the packing rings and seal liner with water or a very **small** amount of oil, and apply a drop of light lubricating oil on the finished faces. Assemble the seal as follows, (see Figure 6).

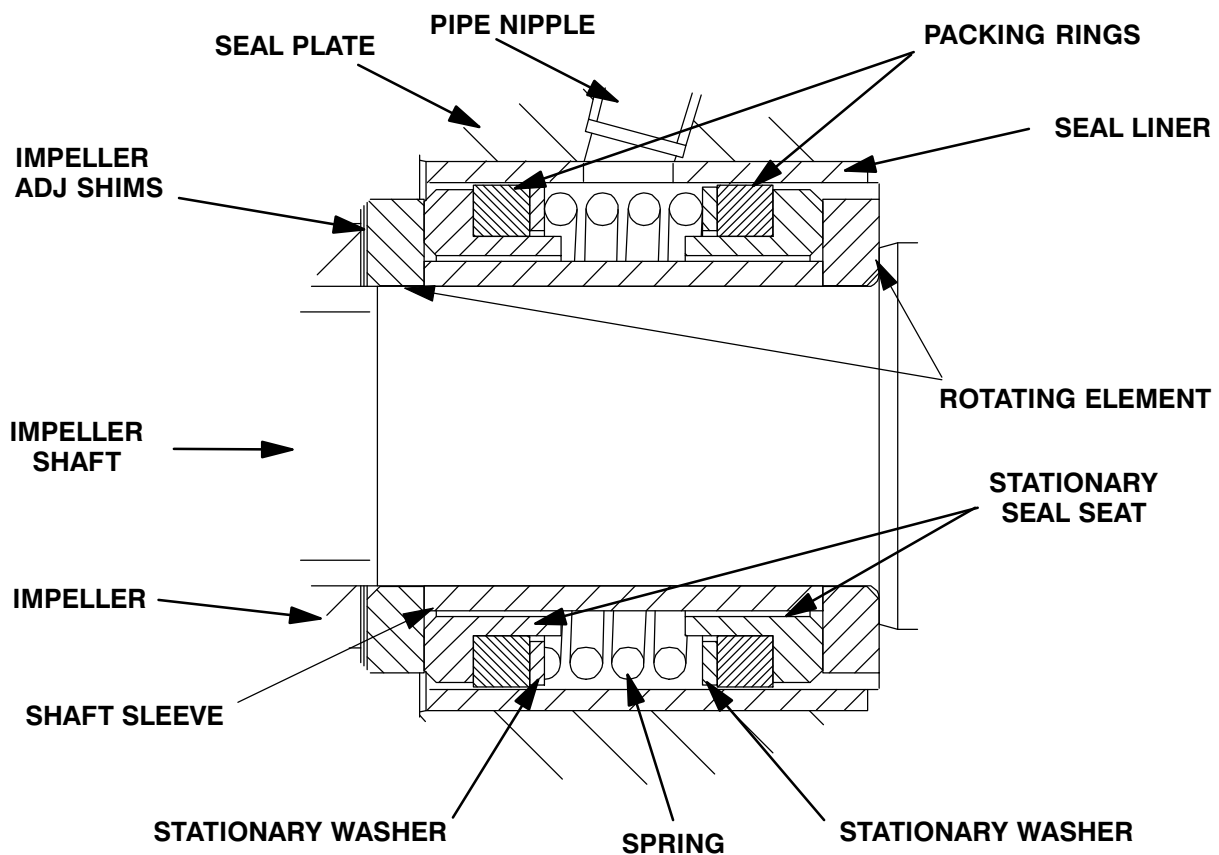

Figure 6. GS1500 Seal Assembly



This seal is not designed for operation at temperatures above 110°F (43°C). Do not use at higher operating temperatures.

Inspect the seal plate, seal liner, and the impeller shaft for burrs or sharp corners, and remove any that exist. Replace the seal liner (38) if wear or grooves exist which could cause leakage or damage to the seal packing rings. To replace the seal liner, position the seal plate (51) on the bed of an arbor (or hydraulic) press and use a new sleeve to force the old one out. After the new liner is properly installed, a 1/4 inch (6,4 mm) diameter hole must be drilled through it to permit the flow of lubricant to the seal assembly. **Be careful** to center the drill in the threaded grease pipe hole and not damage the threads. Deburr the hole from the inside of the seal liner after drilling.

Slide the seal plate onto the shaft until fully seated against the intermediate. Align the threaded seal lubricant hole with the intermediate opening, and temporarily secure the seal plate to the intermediate with two capscrews and nuts (1/2 UNC X 1-1/2 inch long, not supplied).

Install the inboard rotating element with the chamfered side facing the shaft shoulder.

Subassemble the stationary seal seats, packing rings, stationary washers, and spring onto the shaft sleeve. Apply a drop of light oil on the precision finished faces of the stationary seats; **never use grease**. Slide the entire subassembly into the lubricated seal liner until it bottoms against the inboard rotating element.

Install the outboard rotating element with the chamfered side facing the impeller.

Reinstall the automatic grease cup and piping (27, 28, 29 and 30).

Lubricate the seal as indicated in **LUBRICATION**, after the impeller has been installed.

## Impeller Installation And Adjustment

### (Figure 3)

Inspect the impeller, and replace it if cracked or badly worn.



The shaft and impeller threads **must** be completely clean before reinstalling the impeller. Even the slightest amount of dirt on the threads can cause the impeller to seize to the shaft, making future removal difficult or impossible without damage to the impeller or shaft.

Install the same thickness of impeller adjusting shims (22) as previously removed, and screw the impeller onto the shaft until tight.

### NOTE

*At the slightest sign of binding, **immediately** back the impeller off, and check the threads for dirt. **Do not** try to force the impeller onto the shaft.*

A clearance of .020 to .040 inch (0,51 to 1,02 mm) between the impeller and the seal plate is necessary for maximum pump efficiency. Measure this clearance, and add or remove impeller adjusting shims as required.

Remove the two capscrews temporarily holding the seal plate, and install the same thickness of casing gaskets (52) as previously removed. Secure the seal plate and pump casing to the intermediate with the nuts (26). **Do not** fully tighten the nuts until the impeller face clearance has been set.

A clearance of .010 to .020 inch (0,25 to 0,51 mm) between the impeller and the wear plate is also recommended for maximum pump efficiency. This clearance must be set after installing the back cover, by adding or removing gaskets in the pump casing gasket set until the impeller scrapes against the wear plate when the shaft is turned. After the impeller scrapes, add approximately .010 inch (0,25 mm) of gaskets.

### NOTE

*An alternate method of adjusting this clearance is to reach through the discharge port with a feeler gauge and measure the gap. Add or subtract pump casing gaskets accordingly.*

If a lifting eye was used to move the pump casing, **be sure** to remove the lifting eye from the pump casing.



**Do not attempt to lift the complete pump unit using the lifting eye. It is designed to facilitate removal or installation of individual components only. Additional weight may result in damage to the pump or failure of the eye bolt.**

### Suction Check Valve Installation

#### (Figure 3)

Inspect the check valve components, and replace the parts as required. Subassemble the check valve gasket (49) and weights (48 and 50). Position the assembled check valve in the mounting slot in the seat.

### NOTE

*Apply 'Permatex Aviation No. 3 Form-A-Gasket' or equivalent compound to the suction flange and check valve seat mating surfaces before reassembly.*

Replace the seat gasket (78) and secure the check valve and seat to the pump casing with the round head machine screws (69).

Replace the suction flange gasket (65) and secure the suction flange to the check valve seat and pump casing with the hardware (67 and 68).

### Back Cover Installation

#### (Figure 3)

If the wear plate (53) was removed for replacement, carefully center it on the back cover and secure it with the hardware (55 and 56). The wear plate **must** be concentric to prevent binding when the back cover is installed.

Clean any scale or debris from the contacting surfaces in the pump casing that might interfere or prevent a good seal with the back cover. Replace the back cover gasket (57) and slide the back cover assembly into the pump casing. Be sure the wear plate does not bind against the impeller.

### NOTE

*To ease future disassembly, apply a film of grease or 'Never-Seez' on the back cover shoulder, or any surface which contacts the pump casing. This action will reduce rust and scale build-up.*

Secure the back cover assembly by tightening the cover clamp screw (58) against the clamp bar (59). **Do not** over-tighten the clamp screw; it should be just tight enough to ensure a good seal at the back cover shoulder.

### Final Pump Assembly

Install any leveling shims used under the pump casing mounting feet and secure the casing to the base with the previously removed hardware. **Be sure** the pump is secured to the base and engine.

Install the suction and discharge lines and open all valves. Make certain that all piping connections are tight, properly supported and secure.

**Be sure** the pump end and engine have been properly lubricated, see **LUBRICATION**.

### (Figure 3)

Remove the fill cover assembly (12). Fill the pump casing with clean liquid. Reinstall the fill cover plate and gasket (16), and tighten the cover.

Refer to **OPERATION**, Section C, and start the pump.

## LUBRICATION

### Seal Assembly

### (Figure 7)

Fill the grease cup (27) through the grease fitting with No. 2 lithium base grease until grease escapes from the relief hole. Turn the grease cup arm counterclockwise until it is at the top of the stem; this will release the spring to apply grease to the seal (see Figure 7).

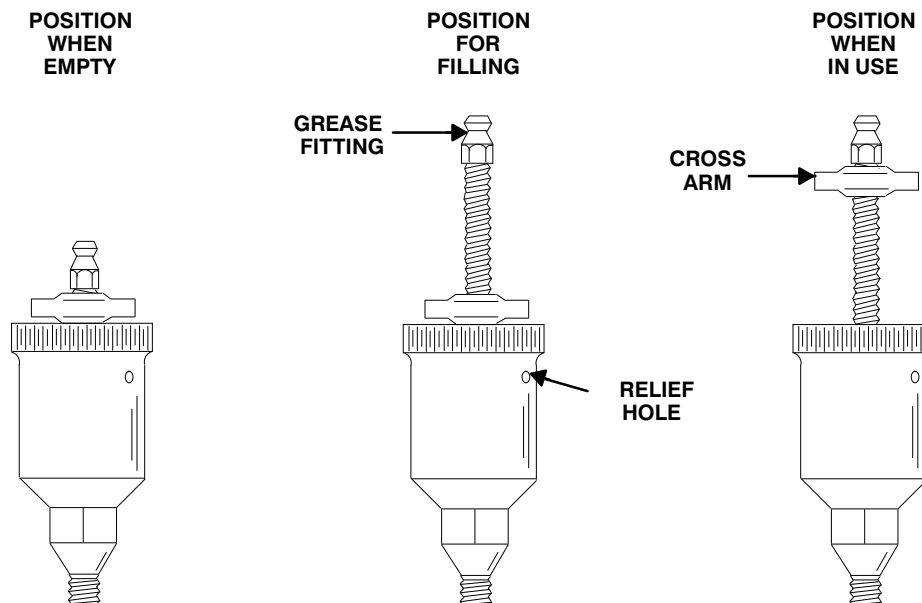

Figure 7. Automatic Lubricating Grease Cup

## Bearings

### (Figure 3)

The intermediate was fully lubricated when shipped from the factory. Check the oil level regularly through the sight gauge (41) and maintain it at the middle of the gauge. When lubrication is required, add SAE No. 30 non-detergent oil through the hole for the oil hole cover (31). **Do not** over-lubricate. Over-lubrication can cause the bearings to over-heat, resulting in premature bearing failure.

### NOTE

*The white reflector in the sight gauge must be positioned horizontally to provide proper drainage.*

Under normal conditions, drain the intermediate once each year and refill with approximately 7–1/2 ounces (22 ml) of clean oil. Change the oil more frequently if the pump is operated continuously or in-

stalled in an environment with rapid temperature change.



Monitor the condition of the bearing lubricant regularly for evidence of rust or moisture condensation. This is especially important in areas where variable hot and cold temperatures are common.

For cold weather operation, consult the factory or a lubricant supplier for the recommended grade of oil.

### Engine

Consult the literature supplied with the power source, or contact your local John Deere engine representative.

**For Warranty Information, Please Visit  
[www.grpumps.com/warranty](http://www.grpumps.com/warranty)  
or call:  
U.S.: 419-755-1280  
Canada: 519-631-2870  
International: +1-419-755-1352**

**GORMAN-RUPP PUMPS**