

# MODEL T10A-SCP



## PUMP SPECIFICATIONS

**Size:** 250 mm x 250 mm DIN 2527 (PN16) Flanged.

**Casing:** Gray Iron 30. Maximum Operating Pressure 6,83 Bar.\*

**Semi-Open Type, Two Vane Impeller:** Ductile Iron 65-45-12. Handles 76,2 mm Diameter Spherical Solids.

**Impeller Shaft:** Stainless Steel 17-4 PH.

**Shaft Sleeve:** Alloy Steel 4130.

**Seal:** Cartridge Type, Mechanical, Oil-Lubricated, Double Floating, Self-Aligning. Tungsten Titanium Carbide or Silicon Carbide Rotating and Stationary Faces\*\*. Stainless Steel 316 Stationary Seat. Fluorocarbon Elastomers (DuPont Viton® or Equivalent). Stainless Steel 18-8 Cage and Spring. Maximum Temperature of Liquid Pumped, 71°C.\*

**Replaceable Front Wear Plate:** Ductile Iron 80-55-06.

**Replaceable Rear Wear Plate:** Carbon Steel 1026.

**Removable Clean-out Cover Plate:** Gray Iron 30; 4 kg.

**Flap Valve:** Neoprene w/Steel Reinforcing.

**Seal Plate:** Gray Iron 30.

**Bearing Housing:** Gray Iron 30.

**Radial and Thrust Bearings:** Open Double Row Ball.

**Bearing and Seal Cavity Lubrication:** SAE 30 Non-Detergent Oil.

**Suction Flange:** Gray Iron 30.

**Suction Head:** Gray Iron 30.

**Gaskets:** Buna-N, PTFE, Cork, and Rubber.

**O-Rings:** Buna-N.

**Hardware:** Standard Plated Steel. Brass Pressure Relief Valve. Bearing and Seal Cavity Oil Level Sight Gauges.

**Models available in different materials:**

T10A3S-B/FM, T10A60S-B/FM, T10A61S-B/FM, T10A71S-B/FM and T10A65S-B/FM\*\*\*.

## MODEL T10A-SCP

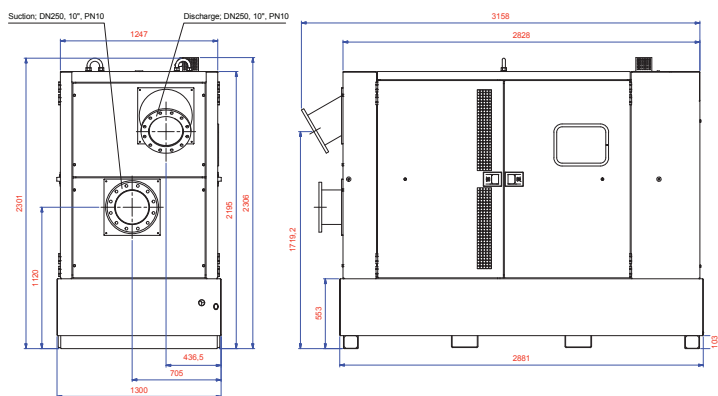

\* Consult Gorman-Rupp Europe for applications exceeding maximum pressure and/or temperature indicated.

\*\* See Pump Specification data sheet for the specific seal face material of construction.

\*\*\* Refer to the Gorman-Rupp specification sheet for details on the available pumps.

## PERFORMANCE CURVE

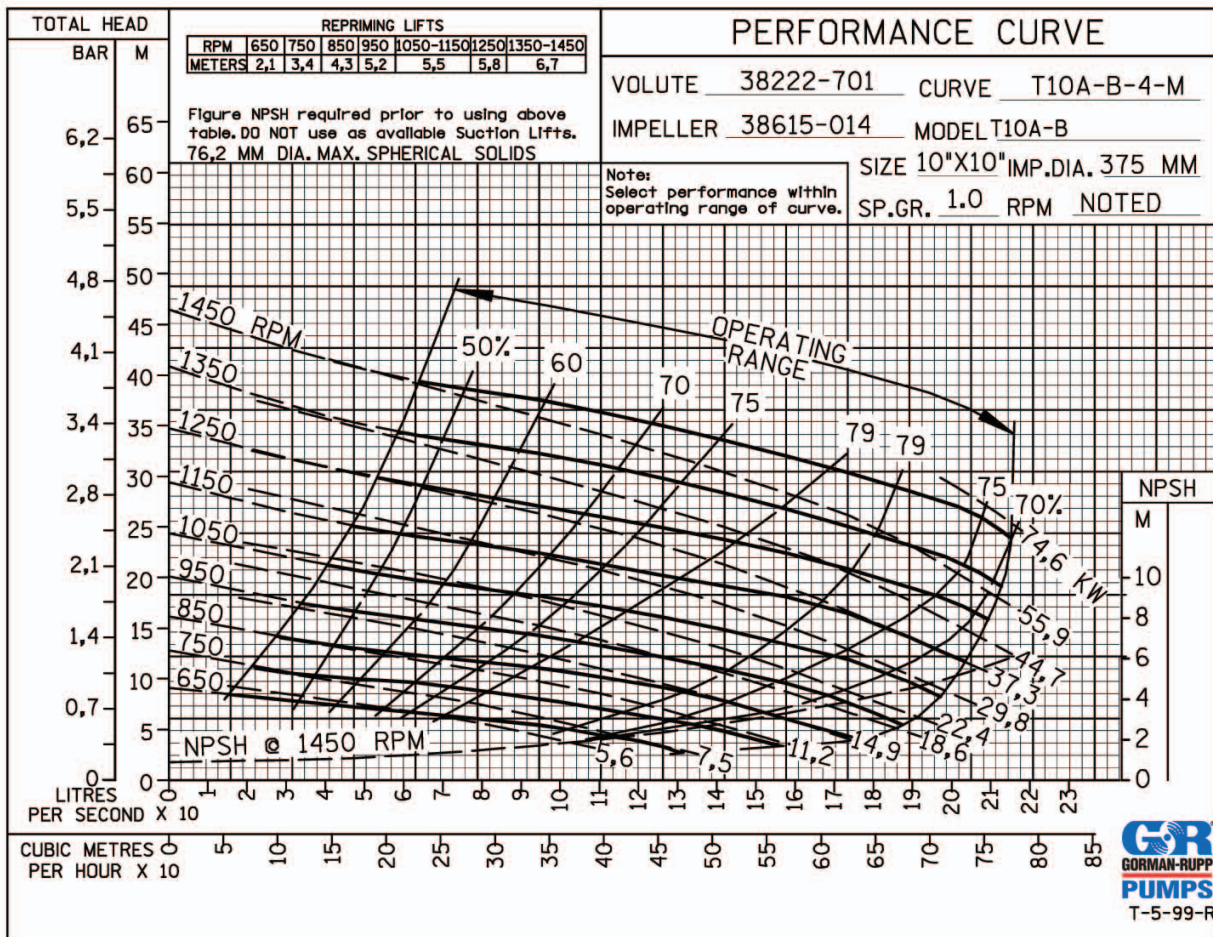

## ENGINE FEATURES

Pump will be driven by a reliable and durable 4 cylinder, four stroke, direct, radiator cooled diesel engine from a well-known engine manufacturer. The engine is specifically designed and chosen for a specific performance which is in line with requirements of the specific Gorman-Rupp pump. This to maximise the output and engine lifetime whilst minimising fuel consumption. Maximum and minimum rpm are set in the engine controls again fine tuned to the engine-pump combination. Consult Gorman-Rupp about applicable engines.

### FEATURES AND EQUIPMENT

- Heavy duty air cleaner
- Inlet and exhaust manifolds
- Fuel lift pump
- Injection pump(s)
- Fuel filter/agglomerator
- Gear-driven positive displacement type lubricating oil pump
- Spin-on lubricating oil filter
- Low oil pressure switch
- Thermostatically-controlled system with circulation pump and belt-driven pusher fan
- Mounted radiator with full guarding
- High engine temperature switch
- Low coolant level switch (not on all models)
- 12V Starter motor
- 12V Alternator
- 12V Stop solenoid
- Operators' handbook

A worldwide network comprising teams of specialists, strategically planned parts stores and all necessary technical facilities ensure comprehensive, competent and reliable service to all customers.

Engine and pump will be mounted in a high quality and robust soundproof canopy.

### Standard Equipment

Single Point Lift. Lockable Access Doors. Manual/ Auto start Engine Control Panel with Display for: Battery voltage, Engine speed, Hours counter and Alarms for low Oil Pressure and high Coolant Temperature. Float Switch (Liquid Level Controller) including Drains. Throttle Control

### Features

- Fully integrated residential exhaust silencer
- Silent exhaust rain cap
- High capacity fully banded fuel tank (min. 24 Hr capacity)
- Oil-water separator
- Steel wire braided fuel lines
- Mechanical fuel gauge
- Large fuel filler cap
- Large access doors
- Key locking stainless steel paddle latches

### Key benefits

- Manufactured from galvanized steel
- Advanced powder coating paint finish to withstand tough site conditions
- Single piece main roof
- Central lifting facility (removeable & replaceable)
- Base frame extends beyond enclosure protecting against handling damage
- Minimal external fixings exposed to environment
- Compact design minimizes transportation costs
- Watertight bodywork ensures protection against ingress of dust and water
- 110% banded (fuel and engine fluids)
- Stackable allowing for easier storage

### Options

- "Deluxe" control panel which monitors an extensive number of engine parameters and will display warnings, shutdown and engine status information on the backlit LCD screen, illuminated LEDs, remote PC and via SMS text alerts (with external modem).
- Hot dip galvanized base
- Spark arrestor
- Solar charger
- Galvanized Suction and discharge
- 3 Way Fuel Valve

### Soundproof Enclosure:

(rated to 67 dba at 7m), Zinc Plated/Powder Coated Corrosion Resistant Enclosure, Exhaust Silencer with Rain Cap, 24 Hour Fuel tank, Spill Containment Base w/Integral Drains and Fork Lift Pockets, Locking Doors, Anti Vibration Mounts.

- Retainers to secure the access doors in the open position
- Spill containment and base with integral drains and forklift pockets
- Anti vibration mounts fitted between base and sub-frame
- Starting battery with leads and terminals
- Single point lifting facility
- "Basic" control panel providing advanced engine monitoring and protection features

- Flame proof oil resistant sound insulation, providing superb noise level retention
- Large lockable doors provide comfortable access for maintenance and prevent unauthorized access to control panel, fuel fill and battery
- Door with Plexiglas window, allowing easy observation of control system
- Fully integrated exhaust system
- Prepared for easy fitting of accessories like spark arrestor, solar panel, air release valve or non-return valve
- Standard DIN suction and discharge flanges
- Document holder for wiring diagrams and manuals

- Air Release Valve
- Anti-Snore Limit Switch
- Discharge Check Valve
- Self-Cleaning Wear Plate
- G-R Hard Iron or Stainless Steel Impeller and Wear Plate
- Pump Temperature shutdown kit
- 240 V Casing Heater
- Battery Isolator