

**Gorman-Rupp Africa (Pty) Limited
Pumpton (Pty) Limited**



**“PRO-FLO”
Basket Strainers**

Designed to meet the stringent requirements of the petro-chemical industry, ‘Pro-Flo’ basket strainers have been engineered to protect valuable plant and equipment in a multitude of applications.

Basket strainers offer the advantage of TOP entry access, facilitating cleaning without mess.

The low profile design enables the ‘Pro-Flo’ to be used where space is limited, for example on pump suction lines.

The standard range is manufactured from ductile iron (SABS 936, Grade SG42).

Each unit is pressure tested to 2400 kPa (certified).

Size range: 50mm - 200mm diameter.

The standard range is flanged to ANSI 150 RF specification.

The strainers are fitted with stainless steel baskets. The large screening area results in low pressure loss.

Basket perforations: 3.2mm Hole x 5.25m.
Staggered pitch x 0.9mm thickness.

Bolted lids ensure that plant standards are complied with.

Optional features include threaded connections for differential pressure instrumentation and de-aerator heads.

Features

- High quality ductile iron casting
- Robust stainless steel basket with large screen area
- Low pressure loss
- Each unit pressure tested to 2400kPa
- Compact low profile design
- Top access
- No mess

• Technical Data •

BASKET STRAINER PRESSURE LOSS CHART

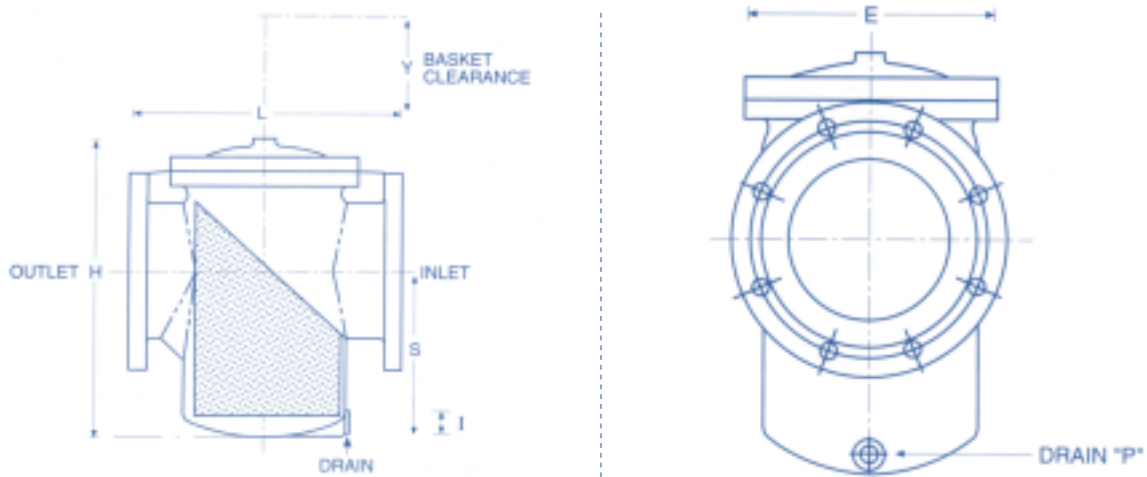
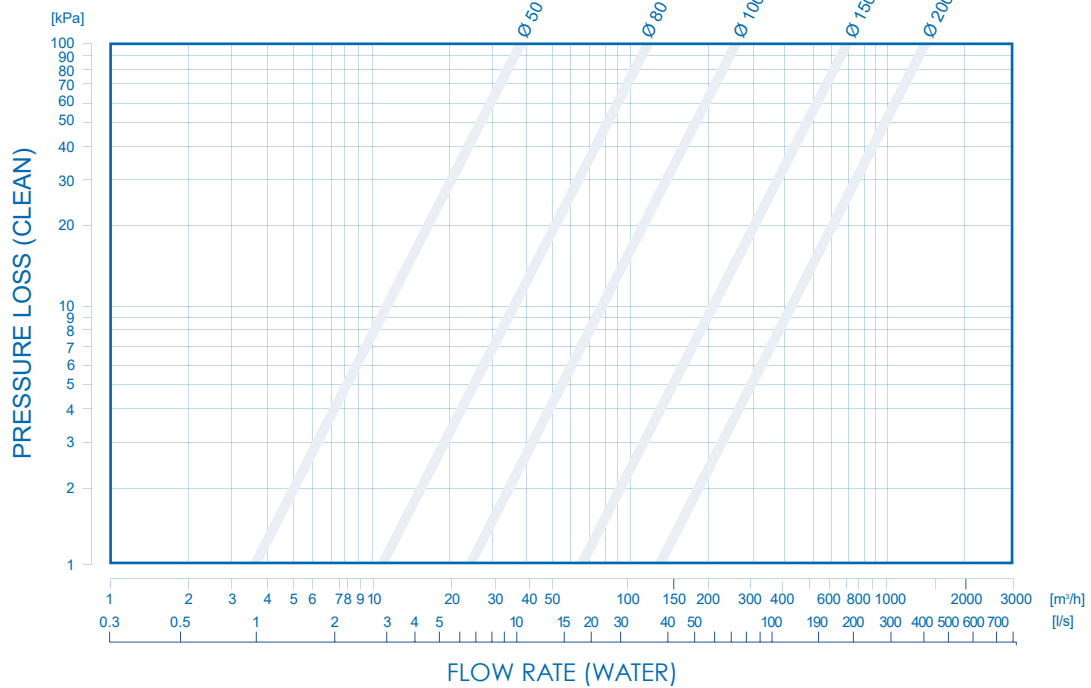

Dimension Data

DIM - (mm)	50 dia	80 dia	100 dia	150 dia	200 dia
H	215	250	300	353	465
L	206	251	292	378	472
S	136	152	183	210	291
E	133	156	190	240	304
I	18	18	18	25	25
P	1/2" NPT	1/2" NPT	1/2" NPT	3/4" NPT	3/4" NPT
Y	226	223	315	371	488
Mass kg	10	19	32	55	120

Above details are subject to change.

• Johannesburg • PO Box 25086 • East Rand 1462 • Phone: +27(0)11 397 3536 •