

# GORMAN-RUPP



A Gorman-Rupp Company

2" AMT

3" AMT



AMT 338B-96

AMT 337B-96

DIAPHRAGM PUMPS

[www.grpumps.eu](http://www.grpumps.eu)



*The Pump People*

# AMT 338B-96 DIAPHRAGM PUMP



## TECHNICAL SPECIFICATIONS

The AMT line of diaphragm pumps features a 2-stage, heavy duty forged gear driven transmission. AMT diaphragm pumps are designed to pump water, mud, slurry, sewage and thick liquids that have the ability to flow.

**2" AMT**



### Electric battery motor for quiet running cordless power!

The AMT diaphragm pumps are supplied with a 2.0kW 3-phase brushless DC electric motor. Thanks to the detachable lithium-ion battery, this pump can be used anywhere with a quiet drive and no exhaust emissions.

**POWER-** 2.0 kW 3-phase DC

**TARE WEIGHT-** 79 kg

**CONSTRUCTION-** Sand Cast Aluminum for low weight, portability and durability

### Self-priming capabilities

Built-in check valve assures self-priming to 6,1 meters after initial prime. Heavy duty forged gear driven transmission is designed to operate the pump at 60 strokes per minute. Each unit includes a 2"NPT steel suction strainer, two NPT nipples and a wheel kit for portability. Suction and discharge port sizes cannot be reduced.

Features:

- Thermoplastic Santoprene diaphragm
- Solids handling: max. 31,7 mm
- Modular component design permits easy maintenance and cleanout



#### PUMP

The AMT 338 (2") diaphragm pump



#### ELECTRIC MOTOR

HONDA GXe 2.0kW 3-phase brushless DC electric motor



#### BATTERY

Detachable 72 V lithium-ion battery, easy to charge via a standard 230V socket



#### PERFORMANCE

Max. 11,3 m<sup>3</sup>/h flow or 7,6 mwc head

Max battery autonomy at full load: 2 hours\*



#### DIMENSIONS

2" x 2"

L: 106,8 cm W: 46,8 cm H: 68,6 cm

\*The maximum autonomy given is to be considered as an indication. Actual performance is dependant on many external factors such as (but not limited to-) temperature, system resistance and the mechanical state of the unit.



The battery and charger are not in the standard supply in AMT 337B-96 / 338B-96 models and need to be ordered separately.



# AMT 337B-96 DIAPHRAGM PUMP



## TECHNICAL SPECIFICATIONS

The AMT line of diaphragm pumps features a 2-stage, heavy duty forged gear driven transmission. AMT diaphragm pumps are designed to pump water, mud, slurry, sewage and thick liquids that have the ability to flow.

**3" AMT**



**Electric battery motor for quiet running cordless power!**

The AMT diaphragm pumps are supplied with a 2.0kW 3-phase brushless DC electric motor. Thanks to the detachable lithium-ion battery, this pump can be used anywhere with a quiet drive and no exhaust emissions.

**POWER-** 2.0 kW 3-phase DC

**TARE WEIGHT-** 79 kg

**CONSTRUCTION-** Sand Cast Aluminum for low weight, portability and durability

### Self-priming capabilities

Built-in check valve assures self-priming to 6,1 meters after initial prime. Heavy duty forged gear driven transmission is designed to operate the pump at 60 strokes per minute. Each unit includes a 3" NPT steel suction strainer, two NPT nipples and a wheel kit for portability.

Suction and discharge port sizes cannot be reduced.

Features:

- Thermoplastic Santoprene diaphragm
- Solids handling: max. 41 mm
- Modular component design permits easy maintenance and cleanout



#### PUMP

The AMT 337 (3") diaphragm pump



#### ELECTRIC MOTOR

HONDA GXe 2.0kW 3-phase brushless DC electric motor



#### BATTERY

Detachable 72 V lithium-ion battery, easy to charge via standard 230V socket



#### PERFORMANCE

Max. 20 m<sup>3</sup>/h  
Max battery autonomy at full load: 1,5 hours \*\*



#### DIMENSIONS

3" x 3"  
L: 106,8 cm W: 46,8 cm H: 68,6 cm

\*\*The maximum autonomy given is to be considered as an indication. Actual performance is dependant on many external factors such as (but not limited to-) temperature, system resistance and the mechanical state of the unit.

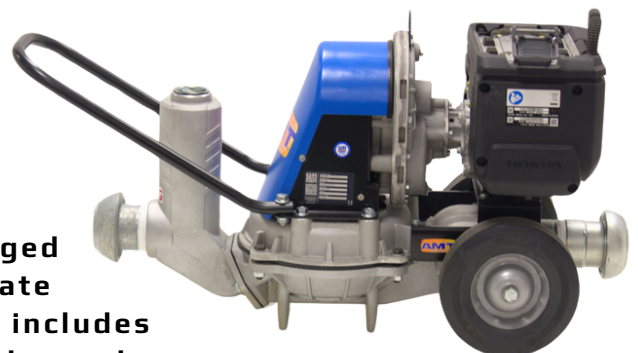

The battery and charger are not in the standard supply in AMT 337B-96 / 338B-96 models and need to be ordered separately.



# AMT 338B-96 / 337B-96 DIAPHRAGM PUMPS



## KEY FEATURES

**The AMT Battery powered membrane pumps offer flexibility and high performance in any application.**

This simple to use pump is driven by a powerful DC electric motor, giving high performance and low sound levels. The unit is powered by a high-quality lithium-ion battery, so you can work from anywhere without having to hassle about with cables, extension cords or anything.

**The Motor : Zero-Emission Electric Power For Construction Machinery**

High-efficiency, high-power 3 phase brushless DC motor for maximum performance and reliability

This advanced electrified power unit accommodates the use in environments that are considered difficult for engine-powered machines, such as indoor work environments and construction work near residential areas where lower noise is an important factor.

No routine maintenance eliminates servicing or costly downtime due to repairs.

The high-performance motor was designed to closely meet the performance output of a conventional petrol engine, making it an ideal battery-powered option.

**The battery**

The use of high-quality lithium-ion battery cells providing optimal performance and fast recharging.

**Fast Charging**

The optional air-cooled fast charger allows you to recharge the battery fast and reliable. It operates on any single phase 230V AC power supply.

**Easy to operate**

The AMT battery powered membrane pumps are very easy to operate. Just turn on the main power, start the motor and control the speed with a simple lever. That's it!

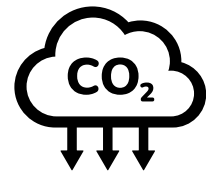

# AMT 338B-96 / 337B-96 DIAPHRAGM PUMPS



## SPECIFICATIONS

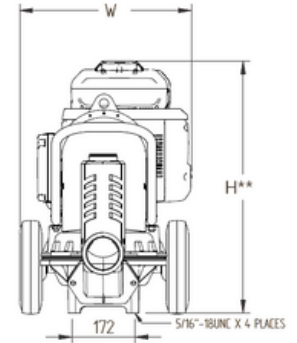
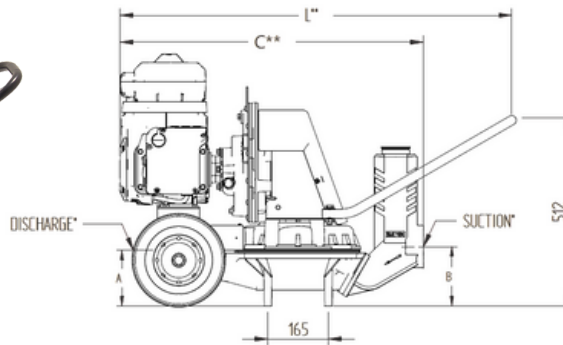
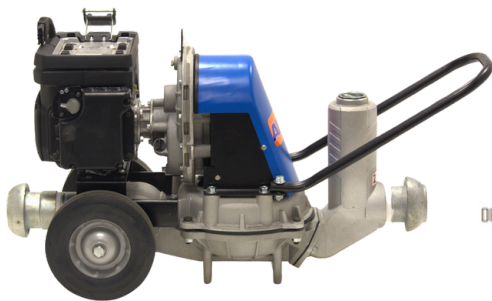

## Dimensions

## Pump Curves

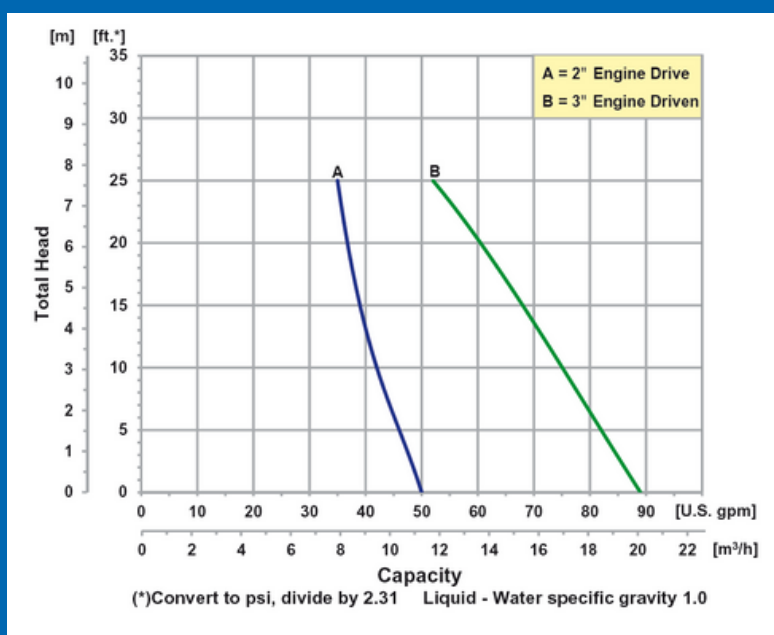

Model	338B-96	337B-96
Nominal size suction x discharge	2"	3"
A (mm)	152	152
B (mm)	162	162
C (mm)	827	827
L (mm)	1068	1068
W (mm)	468	468
H (mm)	686	686

## ACCESSORIES

The AMT diaphragm pumps can be supplied with various accessories such as:

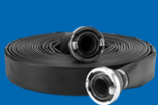

**PRESSURE HOSE**  
Flat roll-up pressure hose. Fitted with storz 81 couplings on both sides.  
Length = 10 meters



**PRESSURE HOSE**  
Flat roll-up pressure hose. Fitted with perrot couplings on both sides (M+F)  
Length = 10 meters



**SUCTION HOSE**  
PVC spiral reinforced Suction hose with basket.  
Length = 5 meters



**SUCTION HOSE**  
PVC spiral reinforced Suction hose without basket.  
Length = 5 meters



**BATTERY**  
The lithium-ion battery for optimum performance and fast charging.



**CHARGER**  
The air-cooled fast charger allows you to quickly charge the battery with any single-phase 230V AC power supply.

\*Contact Gorman-Rupp Europe or your local distributor for more information.

\*\*The battery and charger are not in the standard supply in AMT 337B-96 / 338B-96 models and need to be ordered separately.

\*\*\*Product information is subject to change; consult factory for details. All images are for illustrative purposes only. Actual product may vary from printed representation.



**GORMAN-RUPP**

**PUMPS**

*The Pump People®*



A Gorman-Rupp Company

[www.amtpumps.nl](http://www.amtpumps.nl)

WHERE BLUE  MEETS GREEN

**Gorman-Rupp Europe B.V.**

Zandweistraat 19  
4181 CG Waardenburg  
The Netherlands  
+31 (0)85 7730080  
[GREverkoop@gormanrupp.com](mailto:GREverkoop@gormanrupp.com)

**Gorman-Rupp Belgium**

Rue des Mëtiers  
B-5020 Suarlee (Namur)  
Belgium  
+32 (0)81 409409  
[infoBE@gormanrupp.com](mailto:infoBE@gormanrupp.com)



EUROPE



[www.grpumps.eu](http://www.grpumps.eu)

Product information is subject to change; consult factory for details.  
All images are for illustrative purposes only. Actual product may vary  
from printed representation. © The Gorman-Rupp Europe Company.  
All rights reserved. Printed in the NL.

EU\_REV112024