

MODEL V6A-EDP



PUMP SPECIFICATIONS

Size: 100 mm x 100 mm DIN 2527 (PN16) Flanged.

Casing: Gray Iron 30.

Maximum Operating Pressure 6,55 Bar.*

Semi-Open Type, Two Vane Impeller: Ductile Iron 65-45-12. Handles 76,2 mm Diameter Spherical Solids.

Impeller Shaft: Alloy Steel 4150.

Replaceable Wear Plate: Carbon Steel 1015.

Removable Adjustable Cover Plate: Gray Iron 30; 17 kg.

Seal Plate: Gray Iron 30.

Seal: Cartridge Type, Mechanical, Oil-Lubricated, Double Floating, Self-Aligning Silicon Carbide Rotating and Stationary Faces. Stainless Steel 316 Stationary Seat. Fluorocarbon Elastomers (DuPont VitonR or Equivalent). Stainless Steel 18-8 Cage and Spring. Maximum Temperature of Liquid Pumped 71°C.*

Flap Valve: Neoprene w/Steel Reinforcement.

Shaft Sleeve: Alloy Steel 4130.

Intermediate: Gray Iron 30.

Radial Bearing: Open Single Ball.

Thrust Bearing: Open Double Ball.

Bearing and Seal Cavity Lubrication: SAE 30 Non-Detergent Oil.

Flanges: Gray Iron 30.

Gaskets: Buna-N, Compressed Synthetic Fibers, PTFE, Vegetable Fiber, Cork and Red Rubber.

O-Rings: Buna-N.

Hardware: Standard Plated Steel. Brass Pressure Relief Valve. Bearing and Seal Cavity Oil Level Sight Gauges.

Flange kit: 8" x 6" Metric suct/discharge spoolkit 48213-117

* Consult Factory for Applications Exceeding Maximum Pressure and/or Temperature Indicated.

MODEL V6A-EDP

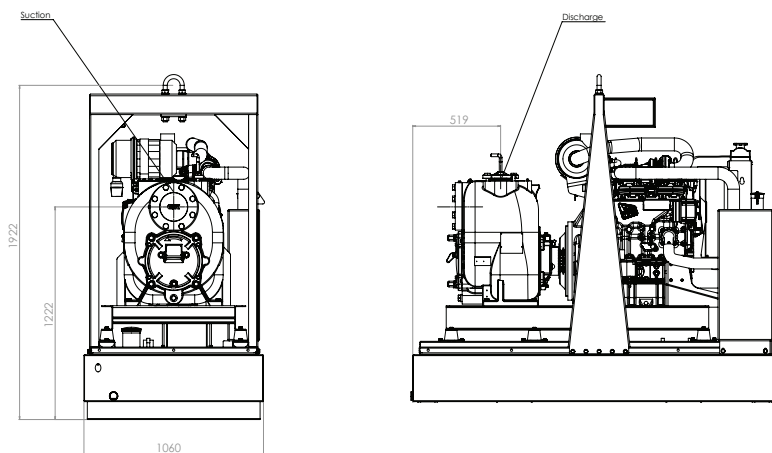

Weight: 1607 kgs

PERFORMANCE CURVE

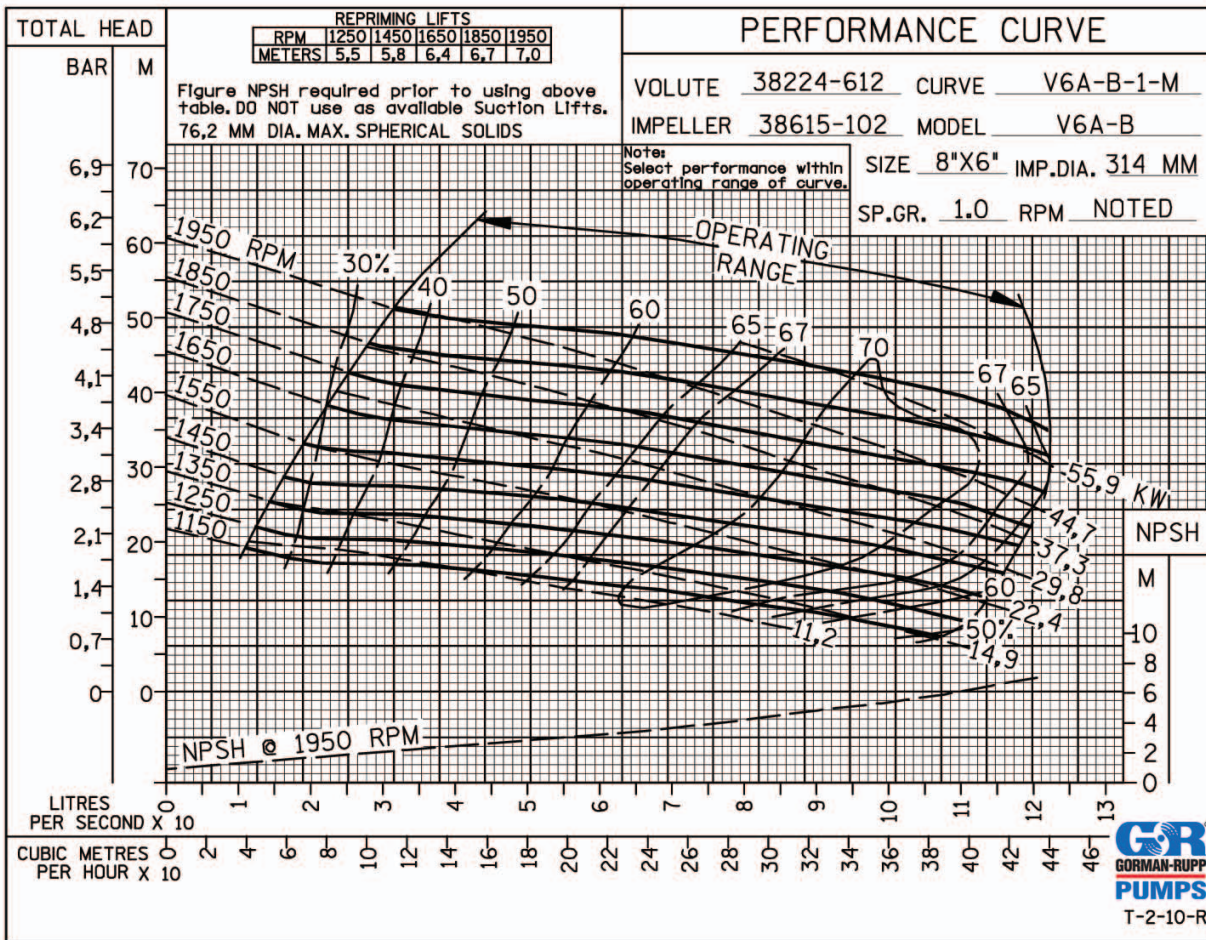

ENGINE FEATURES

Pump will be driven by a reliable and durable 4 cylinder, four stroke, direct, radiator cooled diesel engine from a well-known engine manufacturer. The engine is designed and chosen for a performance which is in line with requirements of the specific Gorman-Rupp pump. This to maximise the output and engine lifetime whilst minimising fuel consumption. Maximum and minimum rpm are set in the engine controls again fine tuned to the engine-pump combination. Consult Gorman-Rupp about applicable engines.

FEATURES AND EQUIPMENT

- Heavy duty air cleaner
- Inlet and exhaust manifolds
- Fuel lift pump
- Injection pump(s)
- Fuel filter/agglomerator
- Gear-driven positive displacement type lubricating oil pump
- Spin-on lubricating oil filter
- Low oil pressure switch
- Thermostatically-controlled system with circulation pump and belt-driven pusher fan
- Mounted radiator with full guarding
- High engine temperature switch
- Low coolant level switch (not on all models)
- 12V Starter motor
- 12V Alternator
- 12V Stop solenoid
- Operators' handbook

A worldwide network comprising teams of specialists, strategically planned parts stores and all necessary technical facilities ensure comprehensive, competent and reliable service to all customers.

Standard Equipment

Single Point Lift. Manual/Auto start Engine Control Panel with Display for: Battery voltage, Engine speed, Hours counter and Alarms for low Oil Pressure and high Coolant Temperature. Float Switch (Liquid Level Controller). Throttle Control.

Features

- Frame mounted exhaust silencer
- High capacity fully bunded fuel tank (min. 24 Hr capacity)
- Oil-water separator
- Steel wire braided fuel lines
- Mechanical fuel gauge
- Large fuel filler cap
- Forklift pockets
- Anti vibration mounts fitted between base and sub-frame
- Starting battery with leads and terminals
- Single point lifting facility
- "Basic" control panel providing advanced engine monitoring and protection features

Key benefits

- Manufactured from galvanized steel
- Advanced powder coating paint finish to withstand arduous site conditions
- Central lifting facility
- Compact design minimizes transportation costs
- 110% bunded (fuel and engine fluids)
- Fully integrated exhaust system