

MODEL PA4E-EDP

PRIMING ASSISTED

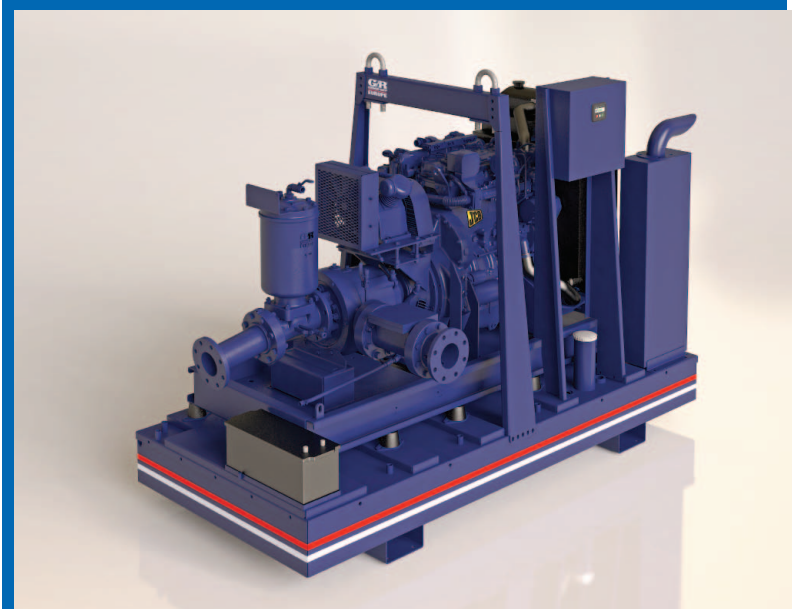

PUMP SPECIFICATIONS

- Size:** 100 mm x 100 mm DIN 2527 (PN16) Flanged.
- Casing:** Gray Iron 30. Maximum Operating Pressure 5,45 Bar.*
- Semi-Open Type, Two Vane Impeller:** G-R Hard Iron. Handles 76,2 mm Diameter Spherical Solids.
- Impeller Shaft:** Stainless Steel 17-4 PH.
- Externally Adjustable, Replaceable Wear Plate:** G-R Hard Iron.
- Intermediate Bracket:** Ductile Iron.
- Seal Plate:** G-R Hard Iron.
- Seal:** Cartridge Type, Mechanical, Oil-Lubricated, Double Floating, Self-Aligning. Silicon Carbide Rotating and Stationary Faces. Stainless Steel 316 Stationary Seat. Fluorocarbon Elastomers (DuPont Viton® or Equivalent). Stainless Steel 18-8 Cage and Spring. Maximum Temperature of Liquid Pumped 71°C.*
- Shaft Sleeve:** Alloy Steel 4130.
- Priming Chamber:** Gray Iron 30 Housing w/ Stainless Steel Float and Linkage.
- Discharge Check Valve:** Ductile Iron Housing w/ Buna-N Flapper.
- Radial Bearing:** Open Single Row Ball.
- Thrust Bearing:** Open Double Row Ball.
- Bearing and Seal Cavity Lubrication:** SAE 30 Non-Detergent Oil.
- Flanges:** Gray Iron 30.
- Gaskets:** Buna-N, Rubber, Cork, and Vegetable Fiber.
- O-Rings:** Buna-N.
- Hardware:** Standard Plated Steel. Bearing and Seal Cavity Oil Level Sight Gauges.
- Priming system:** Venturi

MODEL PA4E-EDP

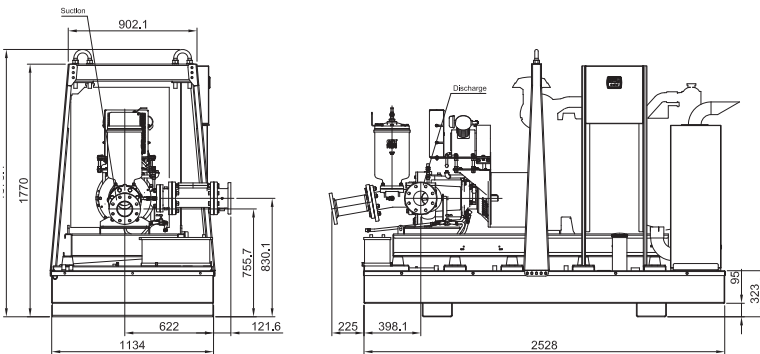

* Consult Factory for Applications Exceeding Maximum Pressure and/or Temperature Indicated.

Specifications and illustrations are subject to change without notice / © Copyright by Gorman-Rupp Europe 2015.

PERFORMANCE CURVE

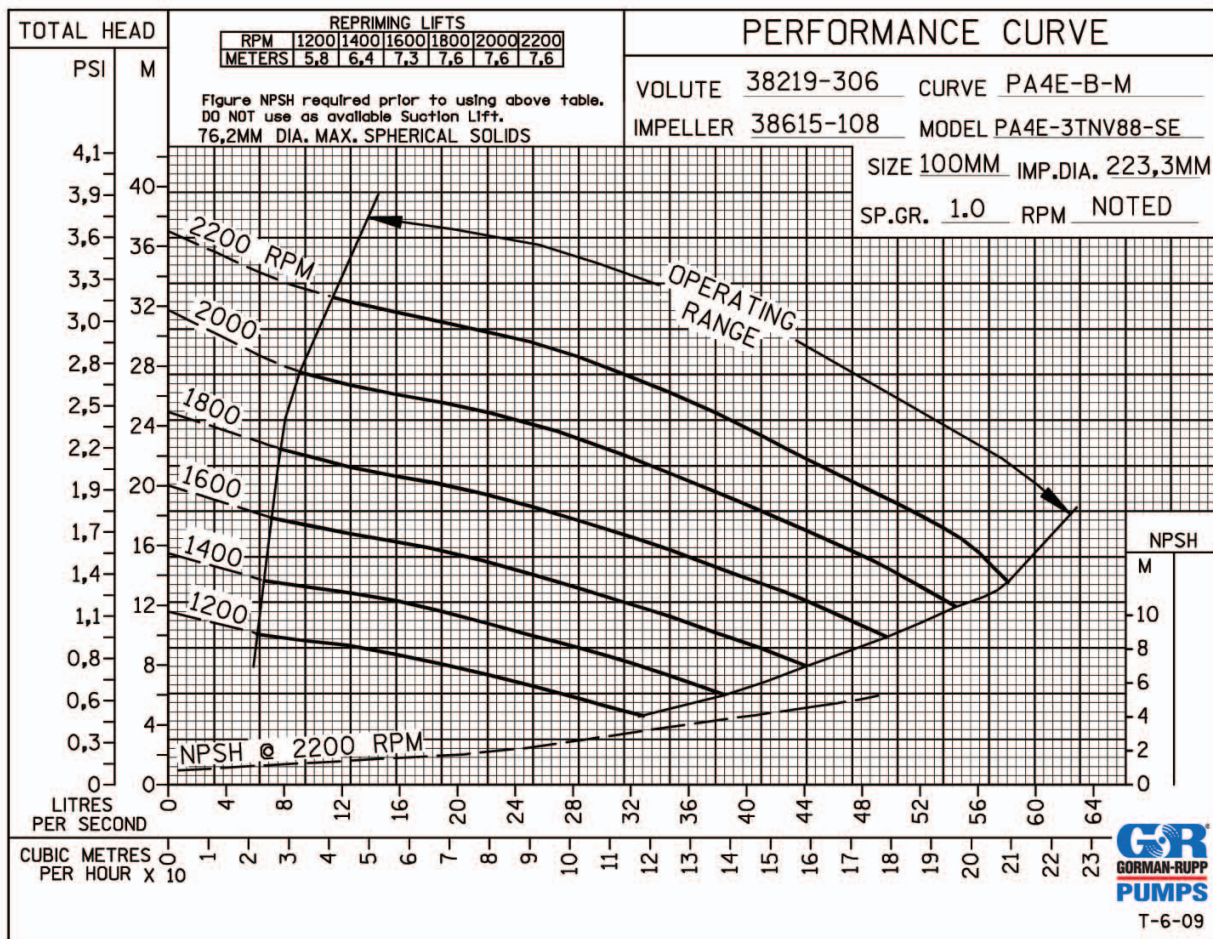

ENGINE FEATURES

Pump will be driven by a reliable and durable 4 cylinder, four stroke, direct, radiator cooled diesel engine from a well-known engine manufacturer. The engine is designed and chosen for a performance which is in line with requirements of the specific Gorman-Rupp pump. This to maximise the output and engine lifetime whilst minimising fuel consumption. Maximum and minimum rpm are set in the engine controls again fine tuned to the engine-pump combination. Consult Gorman-Rupp about applicable engines.

FEATURES AND EQUIPMENT

- Heavy duty air cleaner
- Inlet and exhaust manifolds
- Fuel lift pump
- Injection pump(s)
- Fuel filter/agglomerator
- Gear-driven positive displacement type lubricating oil pump
- Spin-on lubricating oil filter
- Low oil pressure switch
- Thermostatically-controlled system with circulation pump and belt-driven pusher fan
- Mounted radiator with full guarding
- High engine temperature switch
- Low coolant level switch (not on all models)
- 12V Starter motor
- 12V Alternator
- 12V Stop solenoid
- Operators' handbook

A worldwide network comprising teams of specialists, strategically planned parts stores and all necessary technical facilities ensure comprehensive, competent and reliable service to all customers.

Standard Equipment

Single Point Lift. Manual/Auto start Engine Control Panel with Display for: Battery voltage, Engine speed, Hours counter and Alarms for low Oil Pressure and high Coolant Temperature. Float Switch (Liquid Level Controller). Throttle Control.

Features

- Fully integrated residential exhaust silencer
- High capacity fully banded fuel tank (min. 24 Hr capacity)
- Oil-water separator
- Steel wire braided fuel lines
- Mechanical fuel gauge
- Large fuel filler cap
- Spill containment and base with integral drains and forklift pockets
- Anti vibration mounts fitted between base and sub-frame
- Starting battery with leads and terminals
- Single point lifting facility
- "Basic" control panel providing advanced engine monitoring and protection features

Key benefits

- Manufactured from galvanized steel
- Central lifting facility
- Base frame extends beyond enclosure protecting against handling damage
- Minimal external fixings exposed to environment
- Compact design minimizes transportation costs
- 110% banded (fuel and engine fluids)
- Fully integrated exhaust system
- Prepared for easy fitting of accessories like spark arrestor, air release valve or non-return valve
- Standard DIN suction and discharge flanges
- Document holder for wiring diagrams and manuals

Options

- "Deluxe" control panel which monitors an extensive number of engine parameters and will display warnings, shutdown and engine status information on the backlit LCD screen, illuminated LEDs, remote PC and via SMS text alerts (with external modem).
- Hot dip galvanized base
- Spark arrestor
- Solar charger
- Galvanized Suction and discharge
- 3 Way Fuel Valve
- Anti-Snore Limit Switch
- Discharge Check Valve
- G-R Hard Iron or Stainless Steel Impeller and Wear Plate
- Pump Temperature shutdown kit
- Battery Isolator