

SUCTION:
8.00 NOMINAL WITH 8 HOLES
TAPPED .750-10 UNC-2B X 1.00 DEEP
EQUALLY SPACED ON A
11.75/[298,4] DIA BC

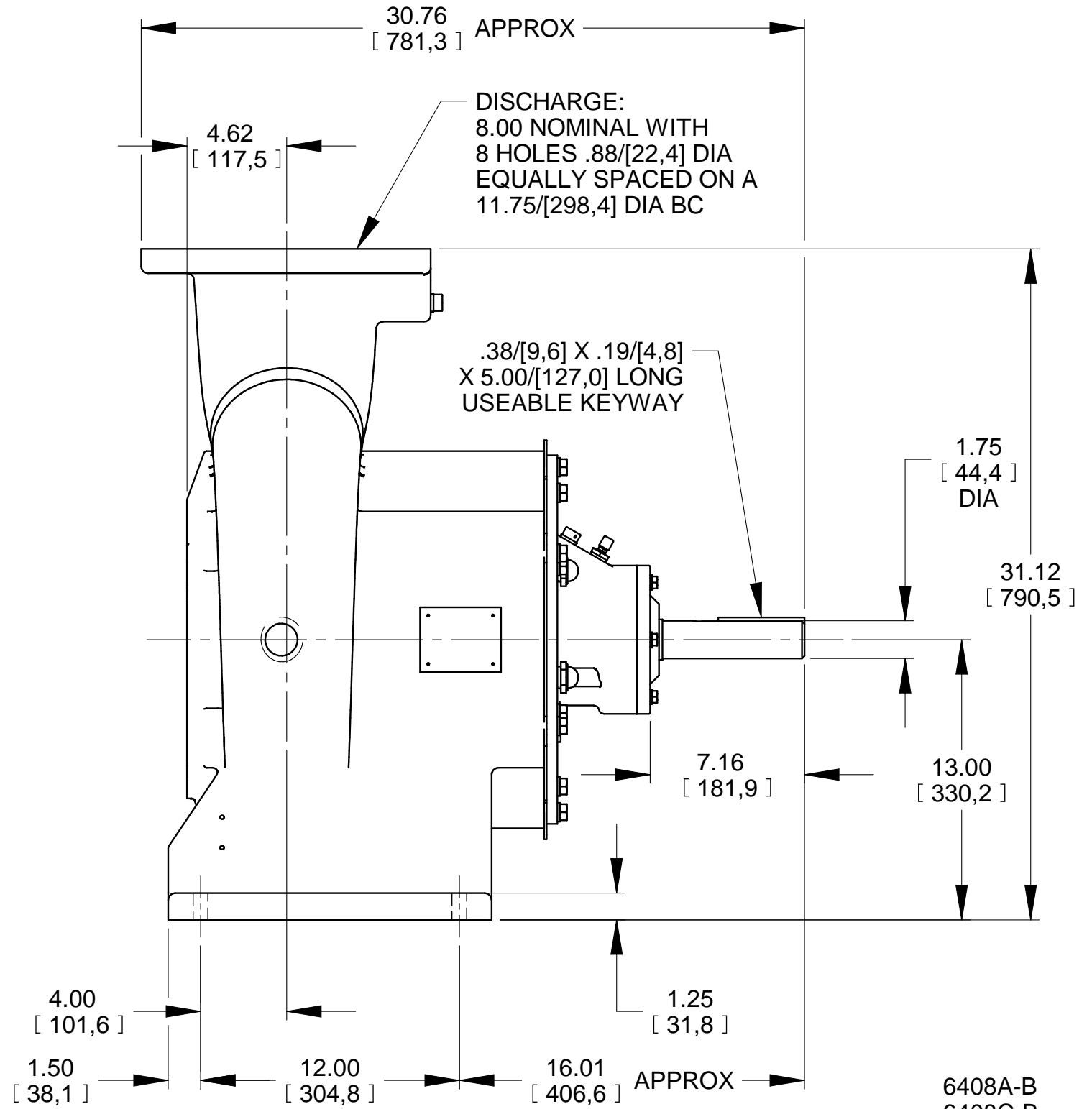
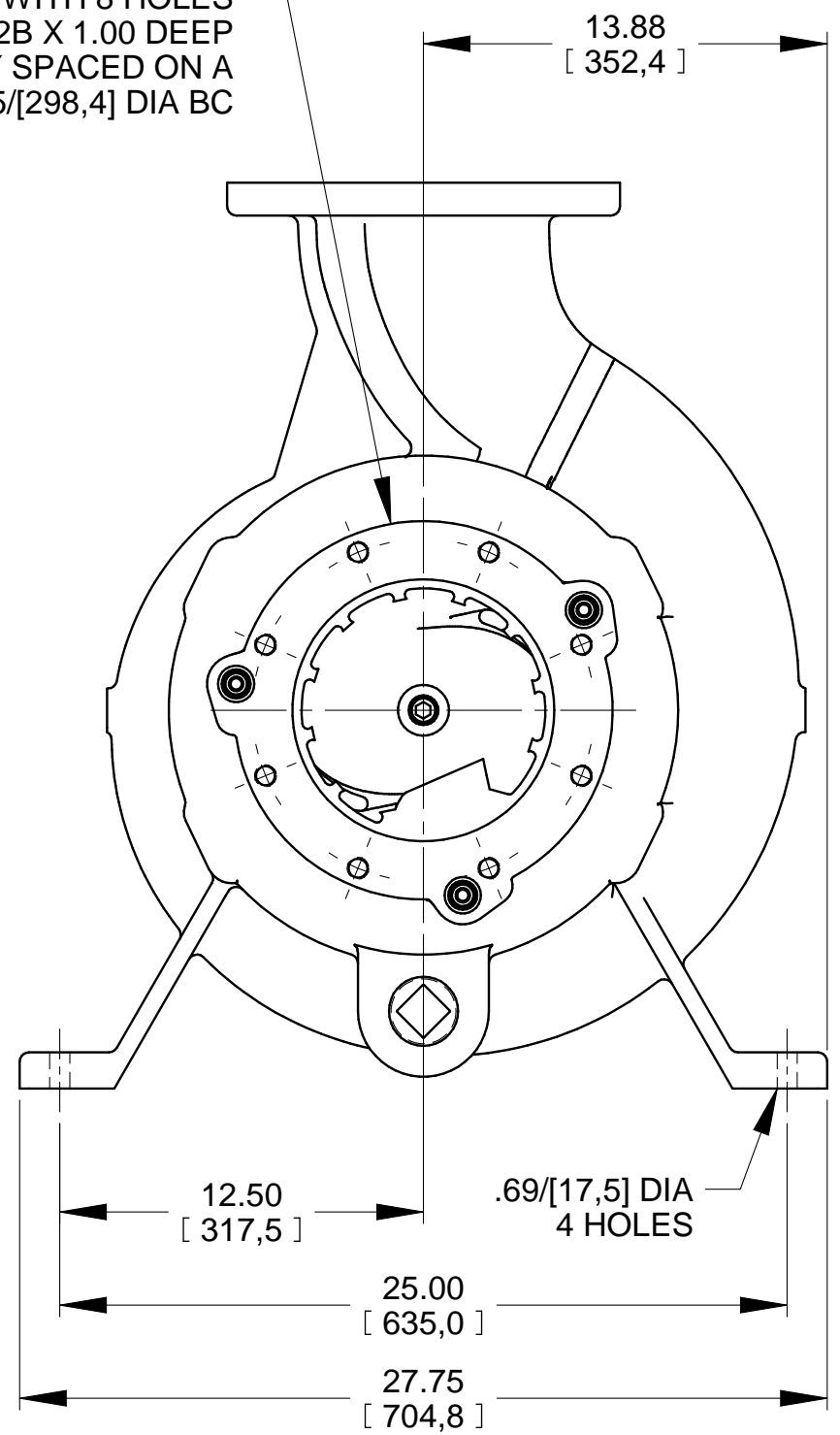

6408A-B
6408C-B
6408D-B
6408E-B

DIMENSIONS:
INCHES
[MILLIMETERS]

24-001

	THE GORMAN-RUPP CO. MANSFIELD, OHIO ST. THOMAS, ONTARIO		DRAWN BY JDM	SCALE 5/32	MODEL NOTED
	DATE 9-15-23	REVISED 3-8-24	OUTLINE NUMBER 19912		