

SUCTION:  
3.00 NOMINAL WITH 4 HOLES  
TAPPED .625-11 UNC-2B X .69 DEEP  
EQUALLY SPACED ON A  
6.00/[152,4] DIA BC

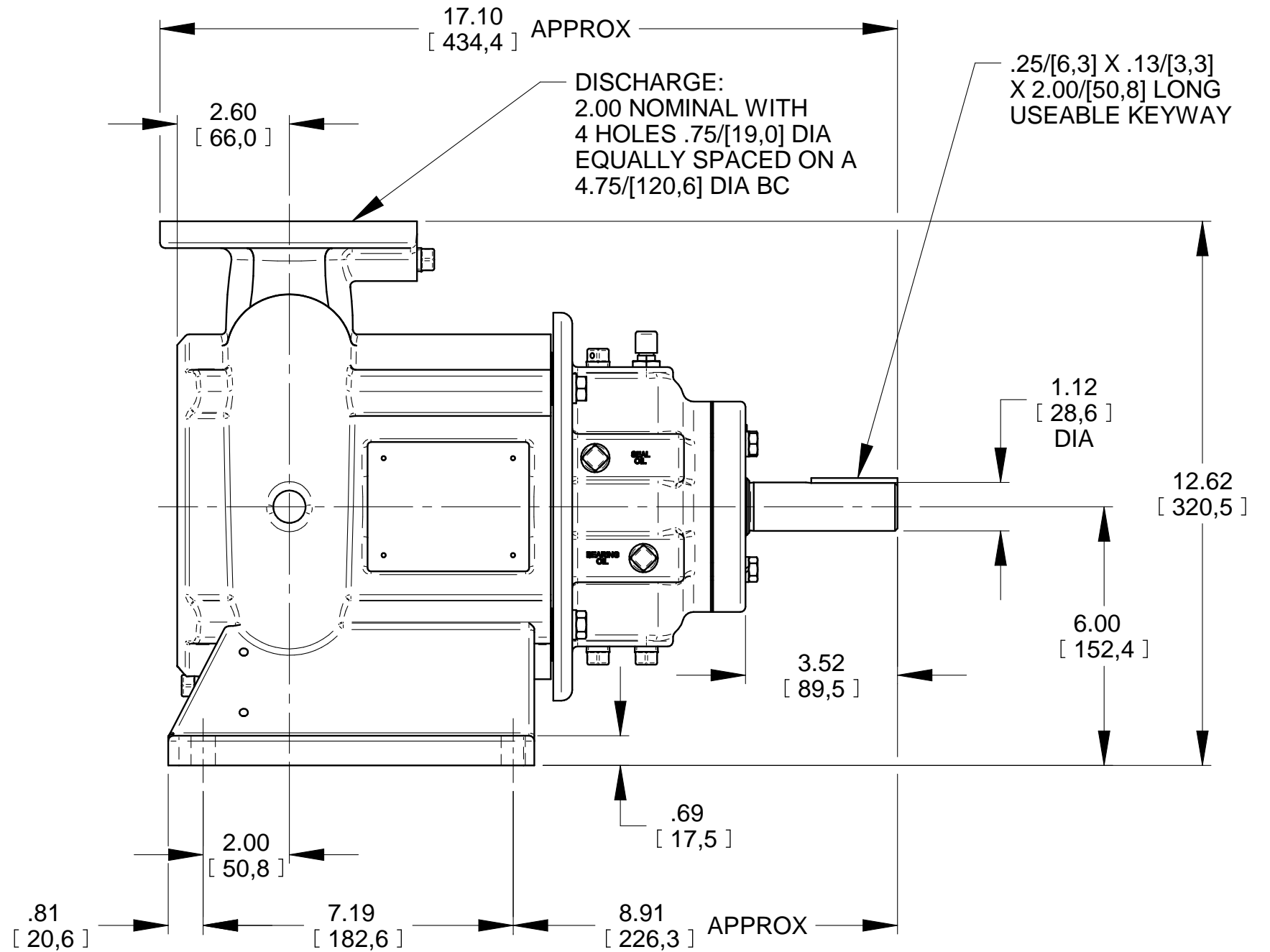
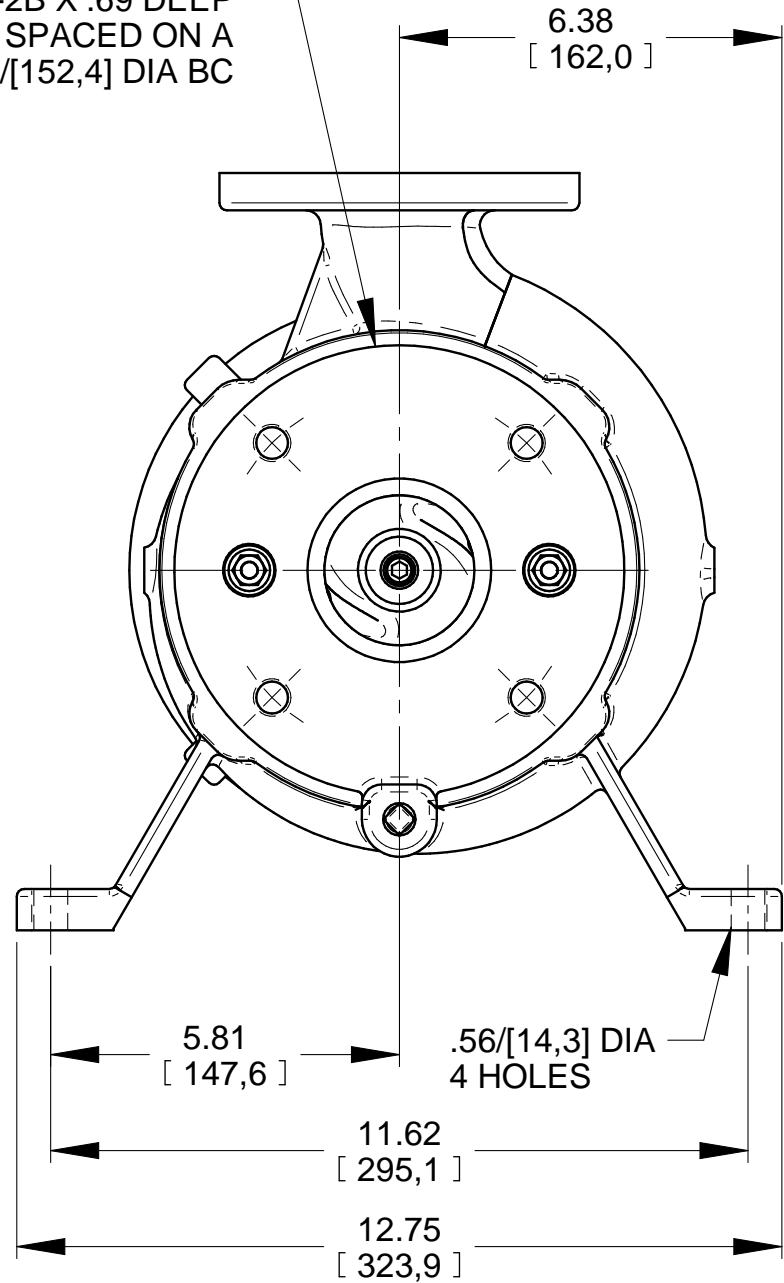

6402C-B  
6402D-B  
6402E-B

DIMENSIONS:  
INCHES  
[MILLIMETERS]

24-001



**THE GORMAN-RUPP CO.**  
MANSFIELD, OHIO ST. THOMAS, ONTARIO

DRAWN BY JDM	SCALE 5/16	MODEL NOTED
DATE 3-17-23	REVISED 2-22-24	OUTLINE NUMBER 19882