

DISCHARGE:
6.00 NOMINAL WITH (8) HOLES
.88/[22,4] DIA EQUALLY SPACED
ON A 9.50/[241,3] DIA BC

SUCTION:
6.00 NOMINAL WITH (8) HOLES
.88/[22,4] DIA EQUALLY SPACED
ON A 9.50/[241,3] DIA B C

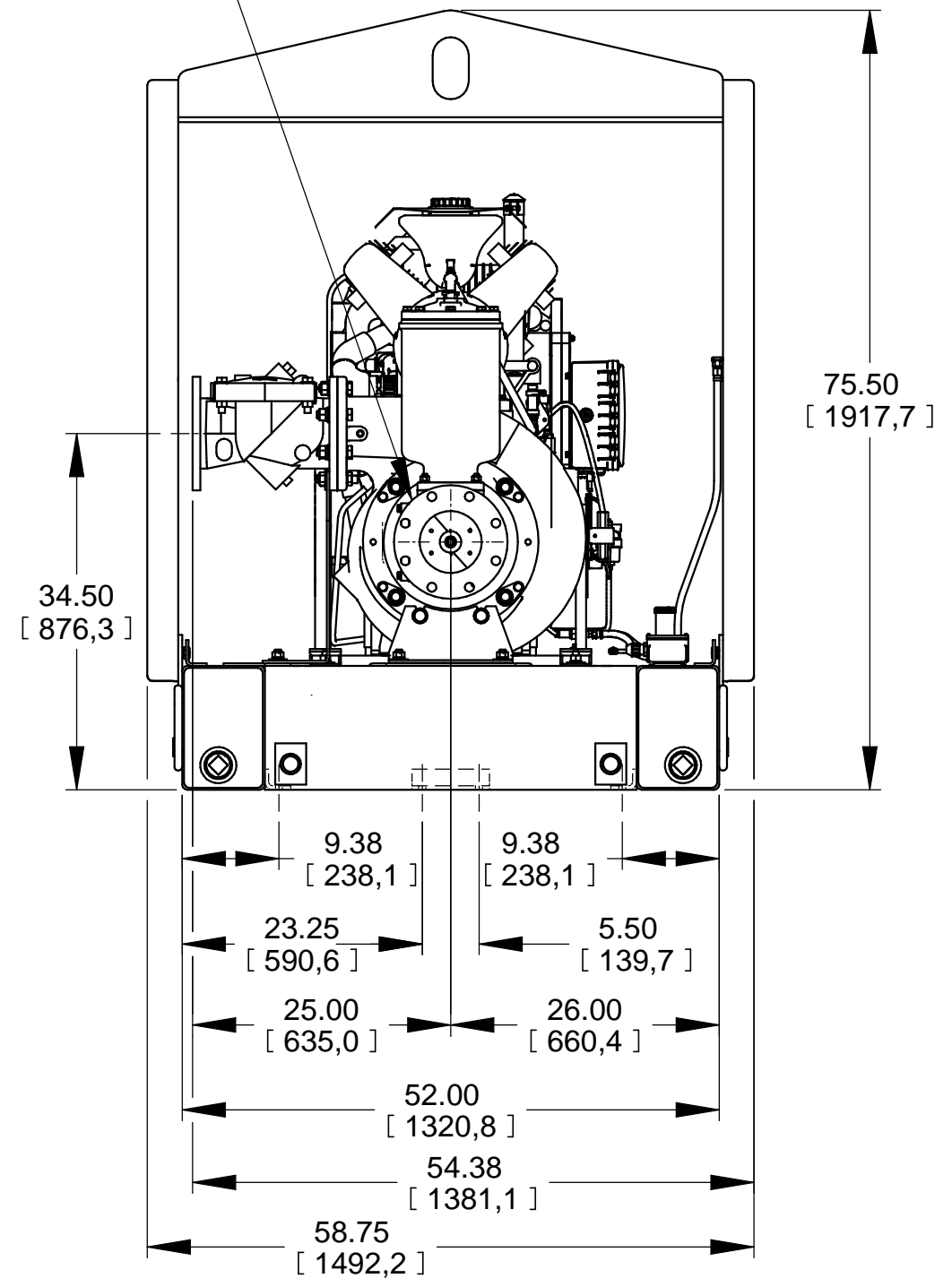
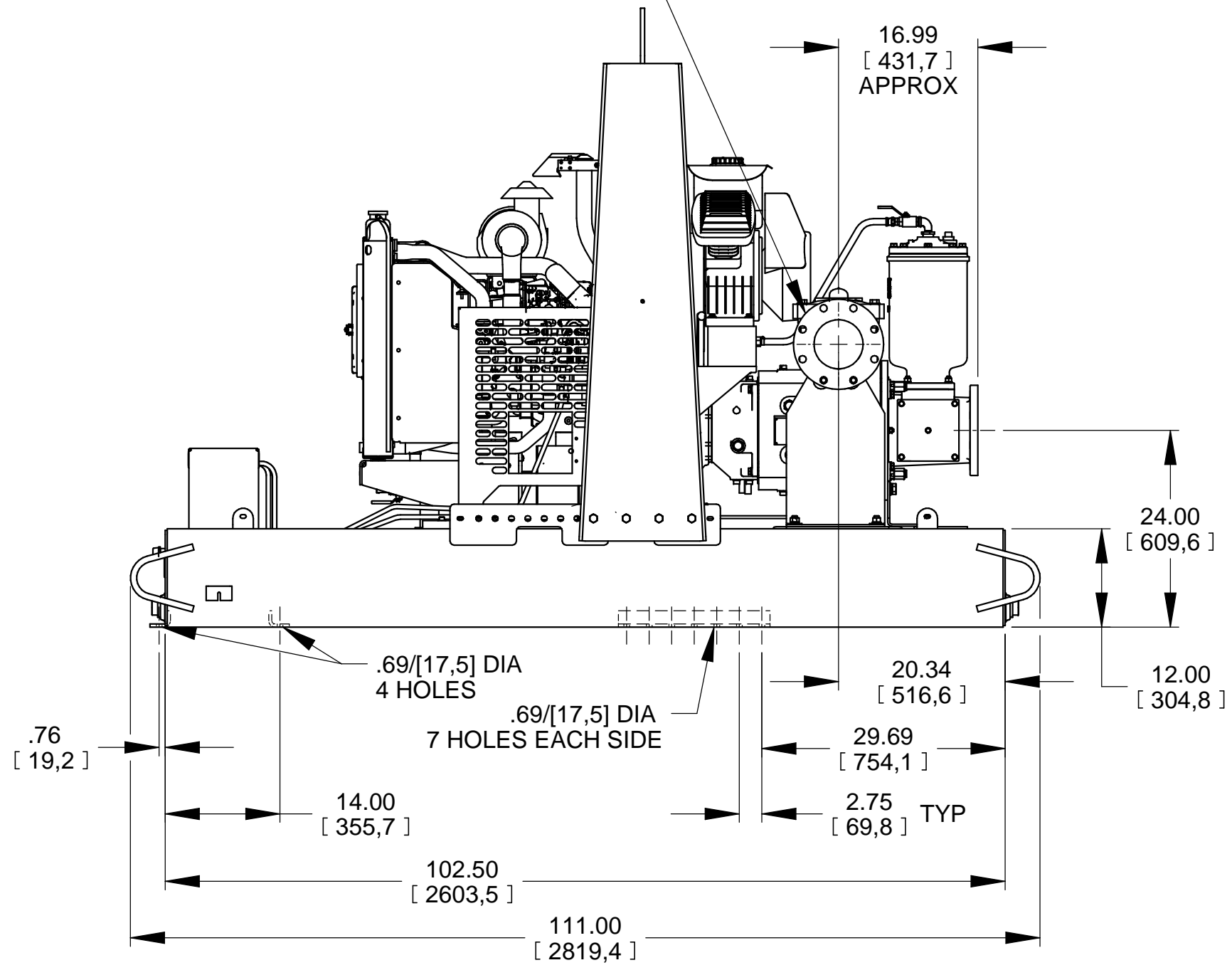

DIMENSIONS:
INCHES
[MILLIMETERS]

POWERED BY: CATERPILLAR C2.2TA FT4 DIESEL ENGINE

	THE GORMAN-RUPP CO. MANSFIELD, OHIO ST. THOMAS, ONTARIO		DRAWN BY REP	SCALE 1/16	MODEL PA6DC-C2.2TA FT4
	DATE 02/21/2020	REVISED -----	OUTLINE NUMBER 19650		