

DISCHARGE:
10.00" NOMINAL WITH
12 HOLES 1.00/[25,4] DIA
ON A 14.25/[362,0] DIA B.C.

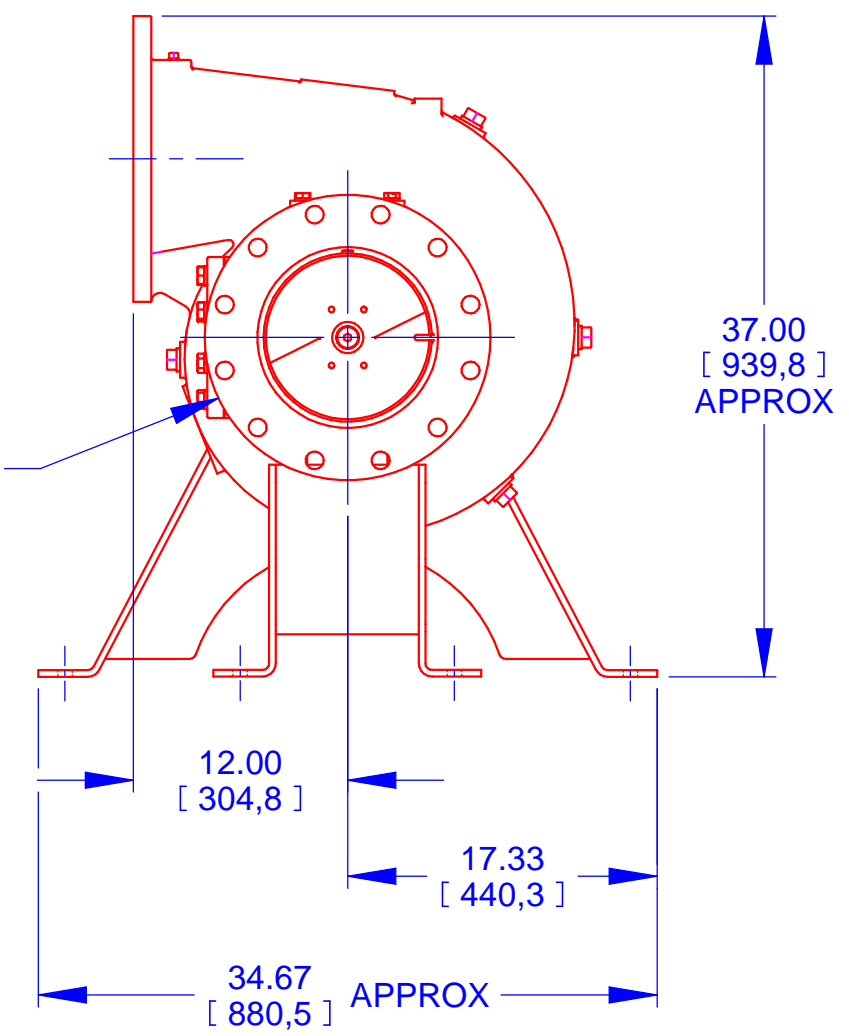

SUCTION:
10.00" NOMINAL WITH
12 HOLES 1.00/[25,4] DIA
ON A 14.25/[362,0] DIA B.C.

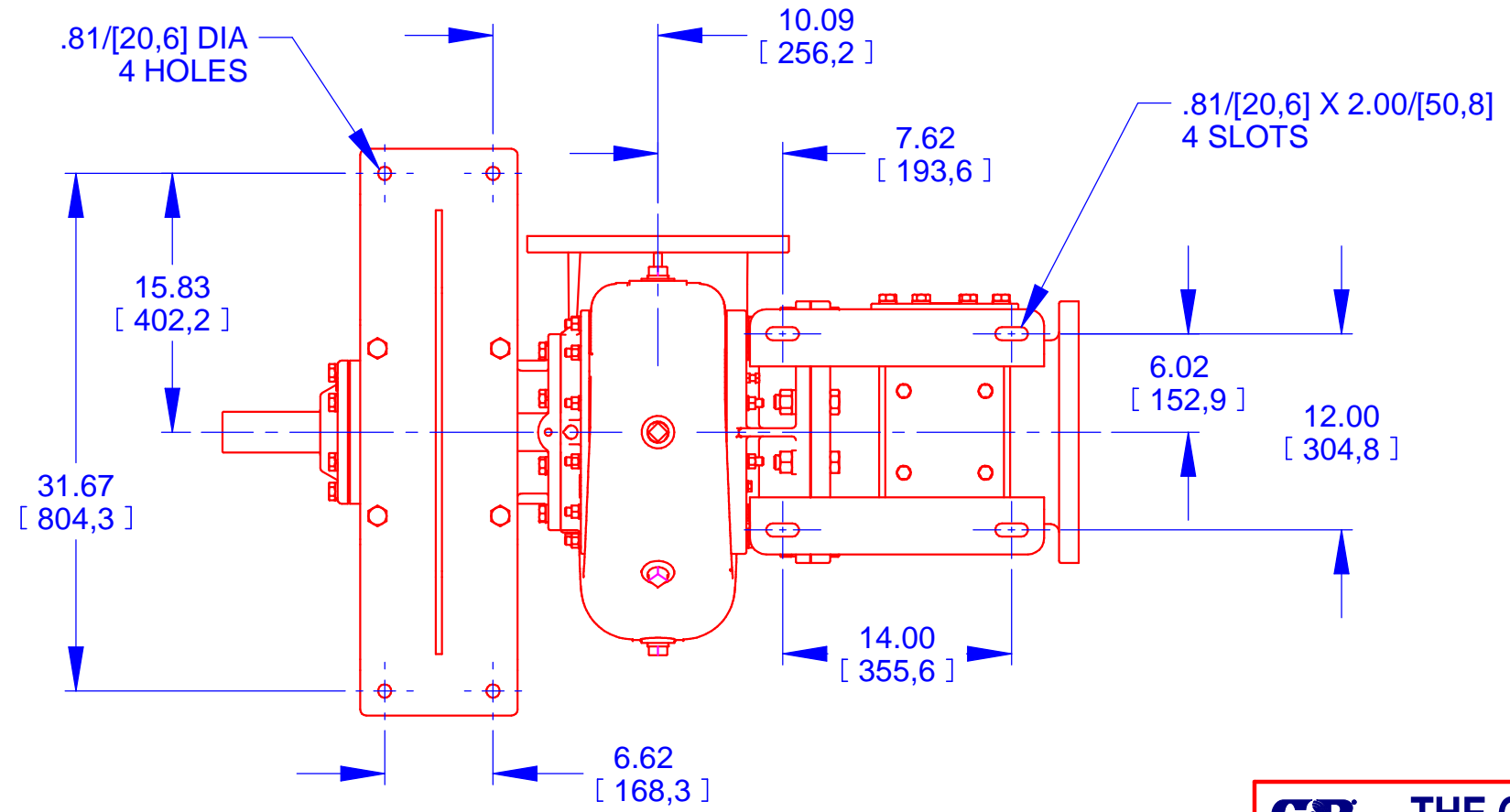

DIMENSIONS:
INCHES
[MILLIMETERS]

	THE GORMAN-RUPP CO. MANSFIELD, OHIO ST. THOMAS, ONTARIO		DRAWN BY JPJ	SCALE 3/32	MODEL 6510C-B
	DATE 3-7-16	REVISED	OUTLINE NUMBER 19249		