

SUCTION:
10.00 NOMINAL WITH
12 HOLES 1.00/[25,4] DIA
EQUALLY SPACED ON A
14.25/[362,0] DIA B. C.

DISCHARGE:
8.00 NOMINAL WITH
8 HOLES .88/[22,4] DIA
EQUALLY SPACED ON A
11.75/[298,5] DIA B. C.

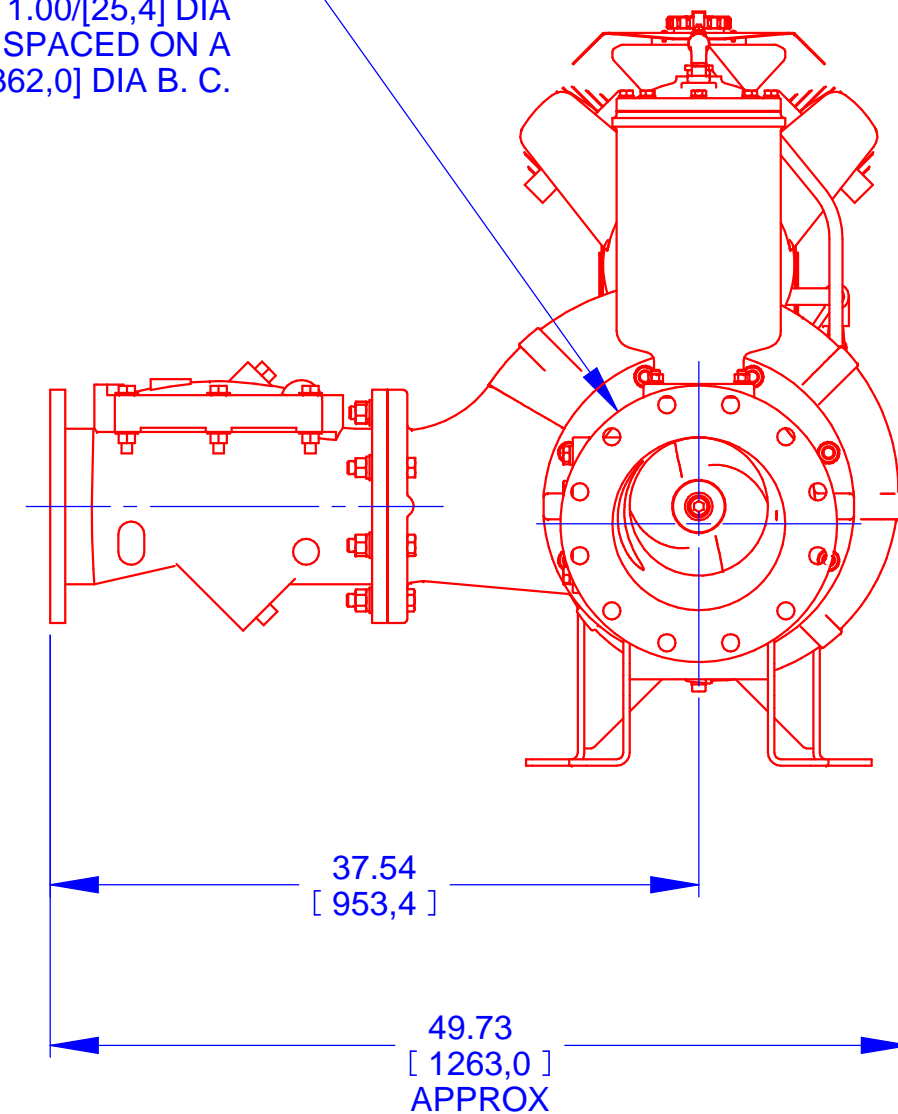

DIMENSIONS:
INCHES
[MILLIMETERS]

MOUNTING HOLE LOCATION



THE GORMAN-RUPP CO.
MANSFIELD, OHIO ST. THOMAS, ONTARIO

DRAWN BY
JPJ
DATE
2-17-16

SCALE
3/32
REVISED

MODEL
PAH8CC-B
OUTLINE NUMBER
19237