

SUCTION:
8.00 NOMINAL WITH
8 HOLES .88/[22,4] DIA
EQUALLY SPACED ON A
11.75/[298,4] DIA BC

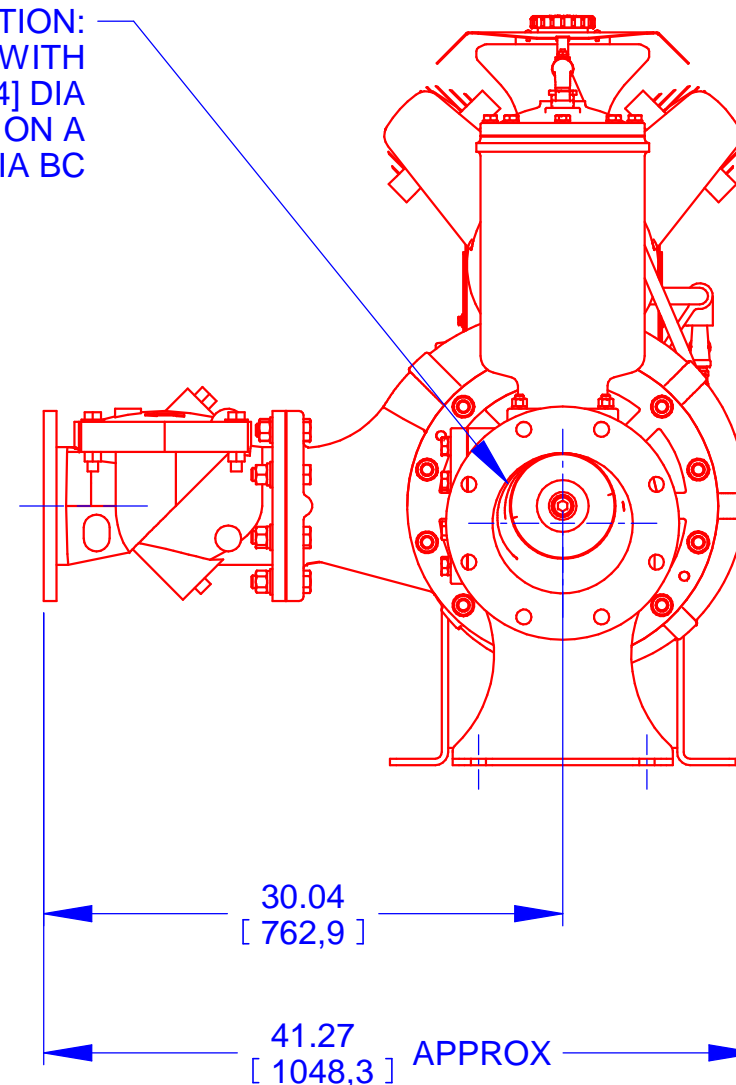

DIMENSIONS:
INCHES
[MILLIMETERS]



THE GORMAN-RUPP CO.
MANSFIELD, OHIO ST. THOMAS, ONTARIO

DRAWN BY
REP
DATE
02/04/16

SCALE
3/32
REVISED

MODEL
PAH6CC-B
OUTLINE NUMBER
19234