

SUCTION:  
3.00 NOMINAL WITH 4 HOLES  
TAPPED .625-11 UNC-2B  
EQUALLY SPACED ON A  
6.00/[152,4] DIA B.C.

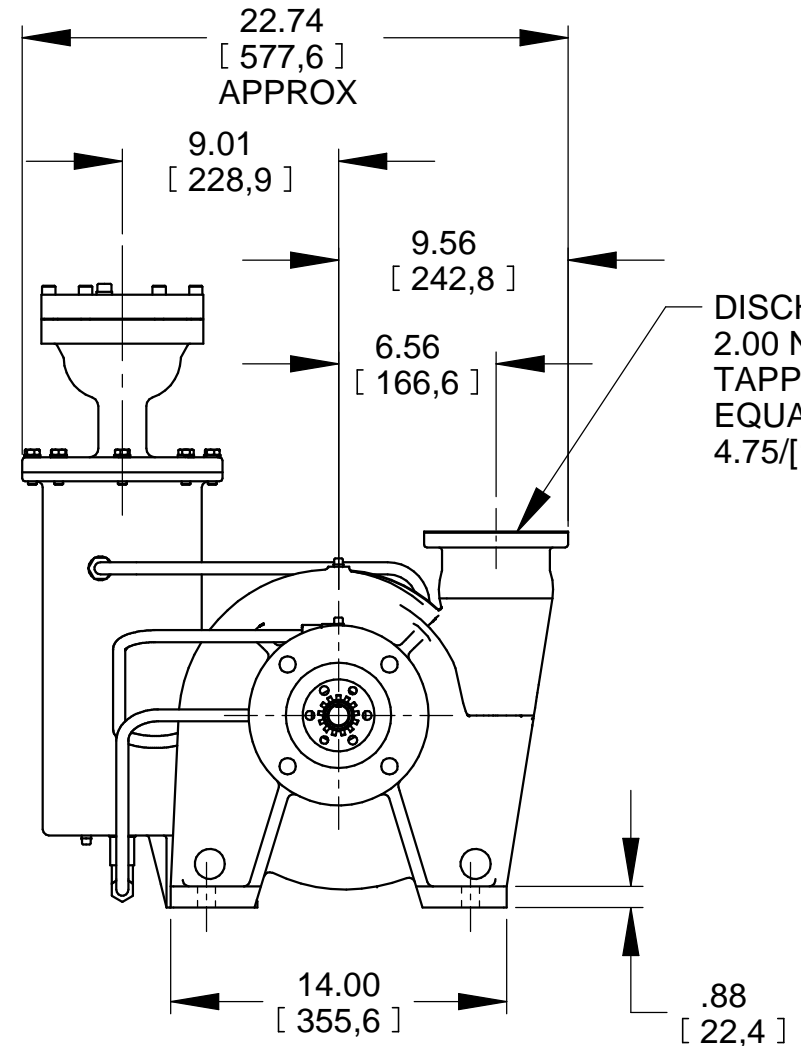

DISCHARGE:  
2.00 NOMINAL WITH 4 HOLES  
TAPPED .625-11 UNC-2B  
EQUALLY SPACED ON A  
4.75/[120,7] DIA B.C.

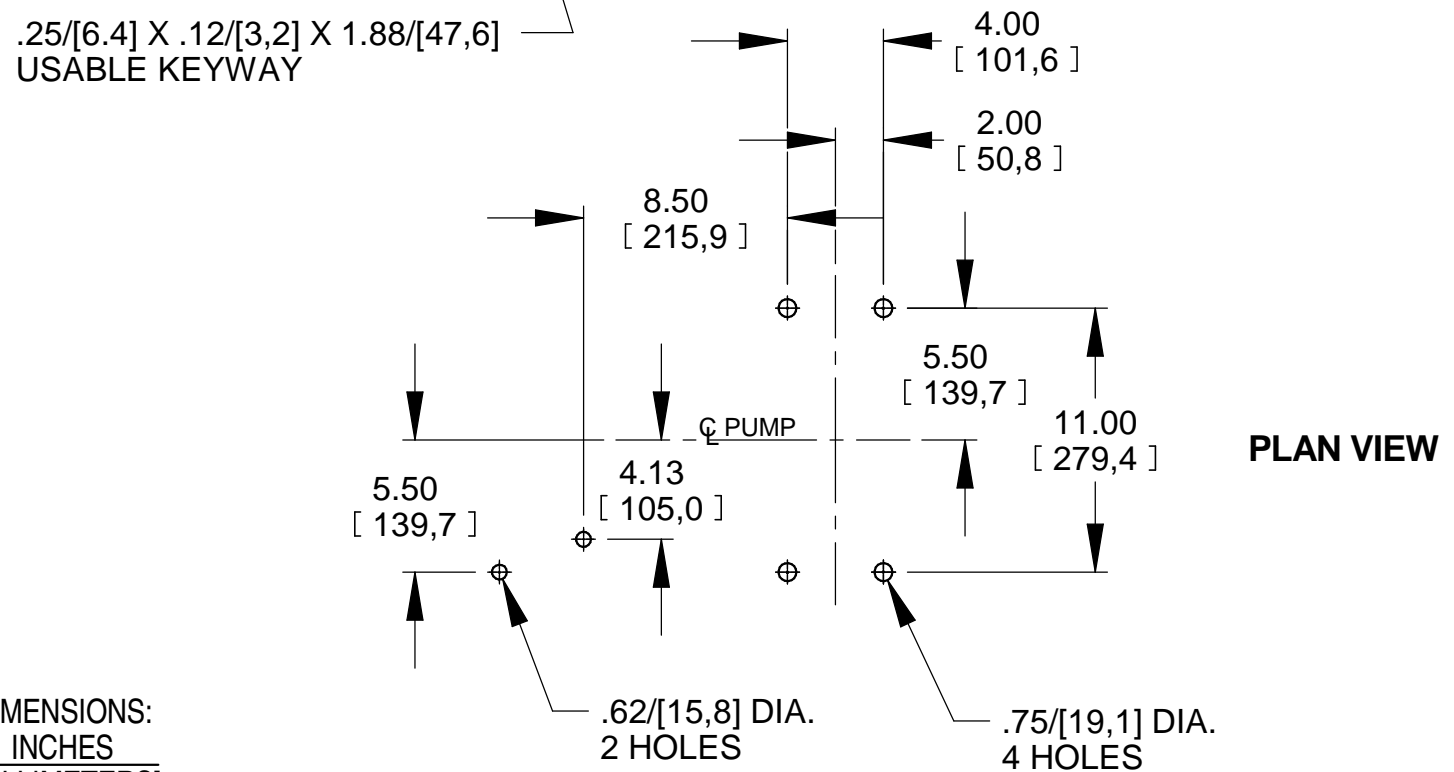

DIMENSIONS:  
INCHES  
[MILLIMETERS]

	<b>THE GORMAN-RUPP CO.</b> MANSFIELD, OHIO ST. THOMAS, ONTARIO		DRAWN BY TAG	SCALE 1/8	MODEL RS2A-BAR
	DATE 10-27-15	REVISED	OUTLINE NUMBER 19197		