

B

19185

SHEET  
1 OF 1

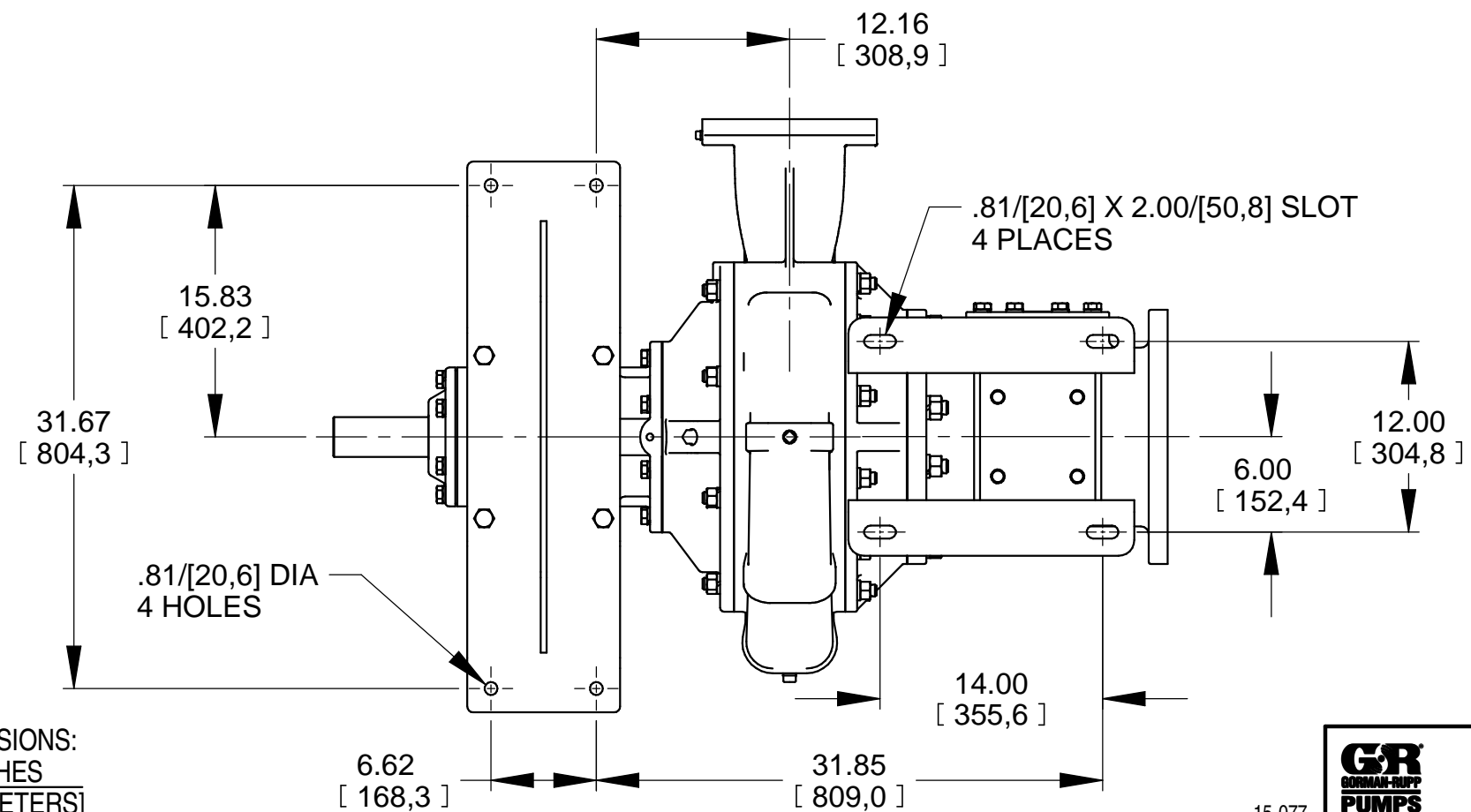
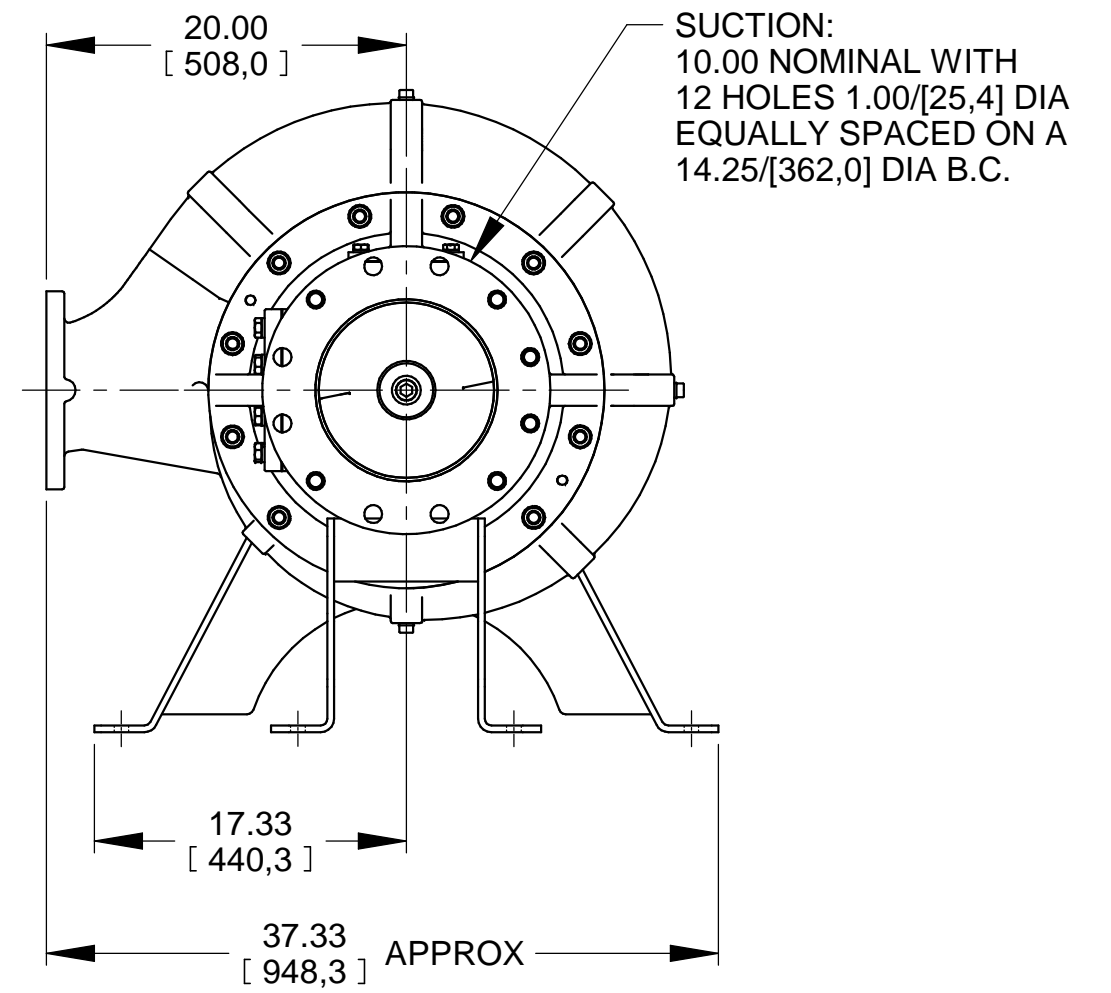
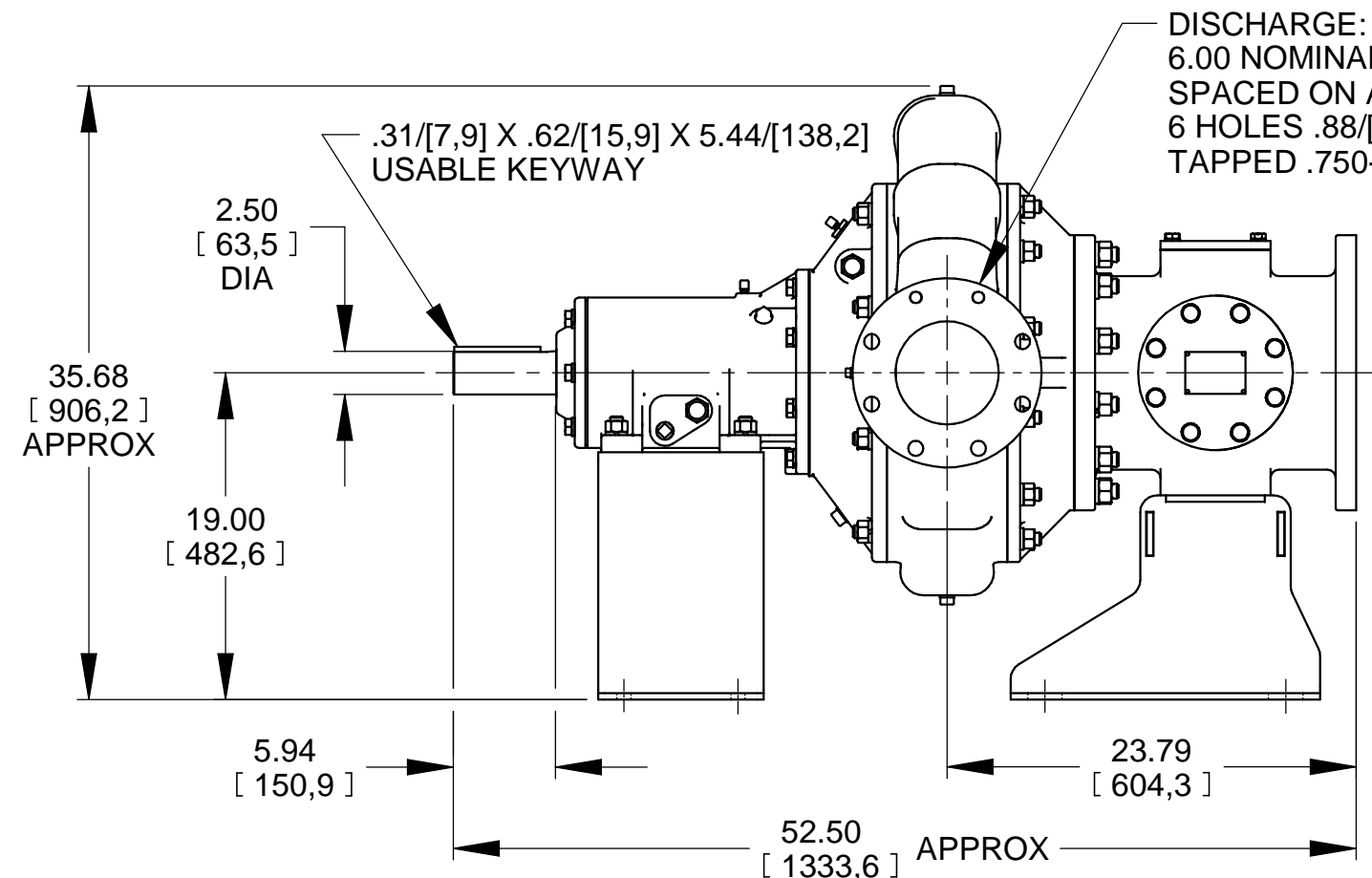

DIMENSIONS:  
INCHES  
[MILLIMETERS]



**THE GORMAN-RUPP CO.**  
MANSFIELD, OHIO ST. THOMAS, ONTARIO

DRAWN BY ALE	SCALE 3/32	MODEL 6506A-B
DATE 10-15-15	REVISED 1-4-16	OUTLINE NUMBER 19185

15-077