

18568

B 19171

SHEET  
1 OF 1

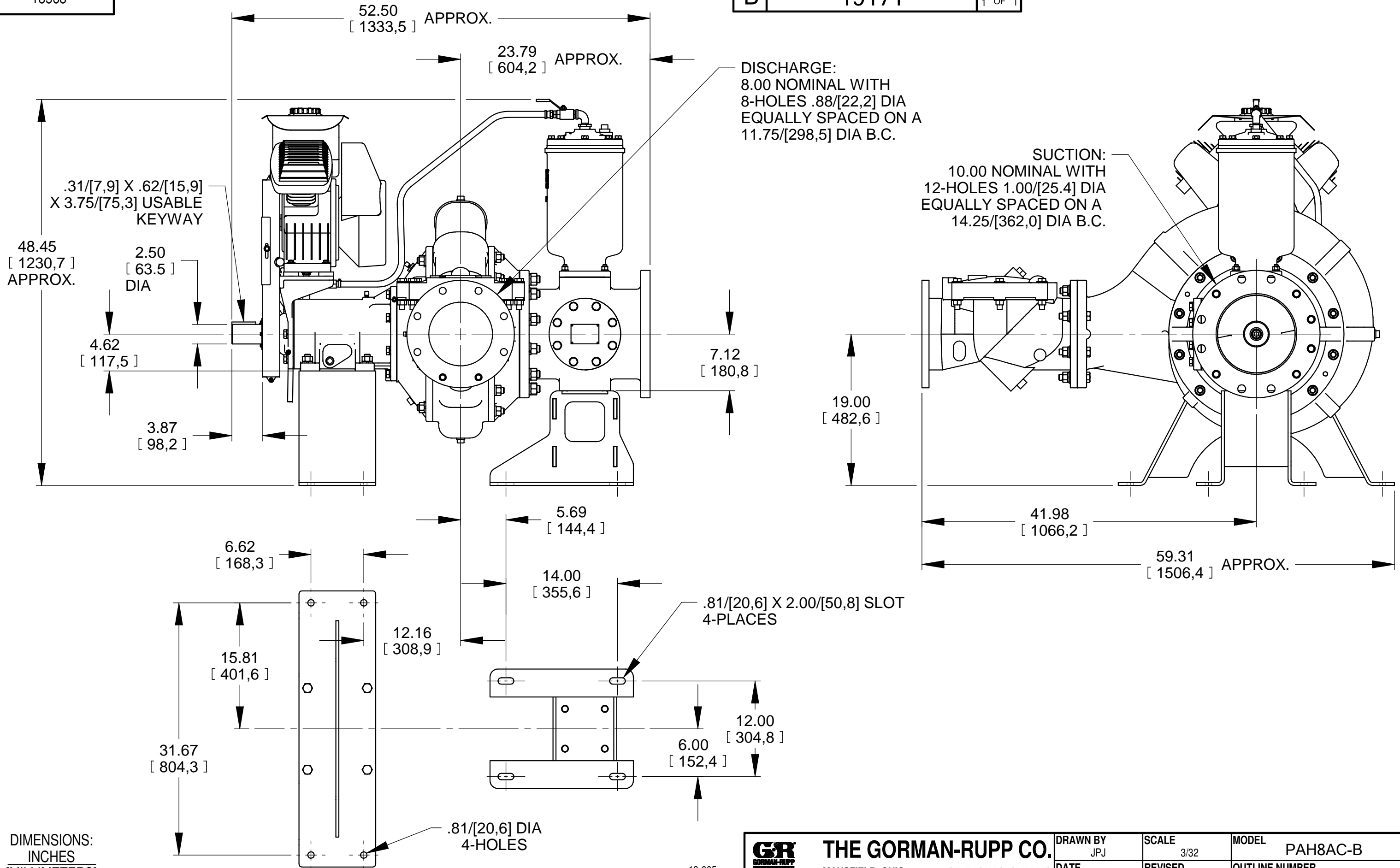

DIMENSIONS:  
INCHES  
[MILLIMETERS]

18-005



**THE GORMAN-RUPP CO.**  
MANSFIELD, OHIO ST. THOMAS, ONTARIO

DRAWN BY JPJ	SCALE 3/32	MODEL PAH8AC-B
DATE 8-25-15	REVISED 7-16-18	OUTLINE NUMBER 19171