

18555

B 19170

SHEET 1 OF 1

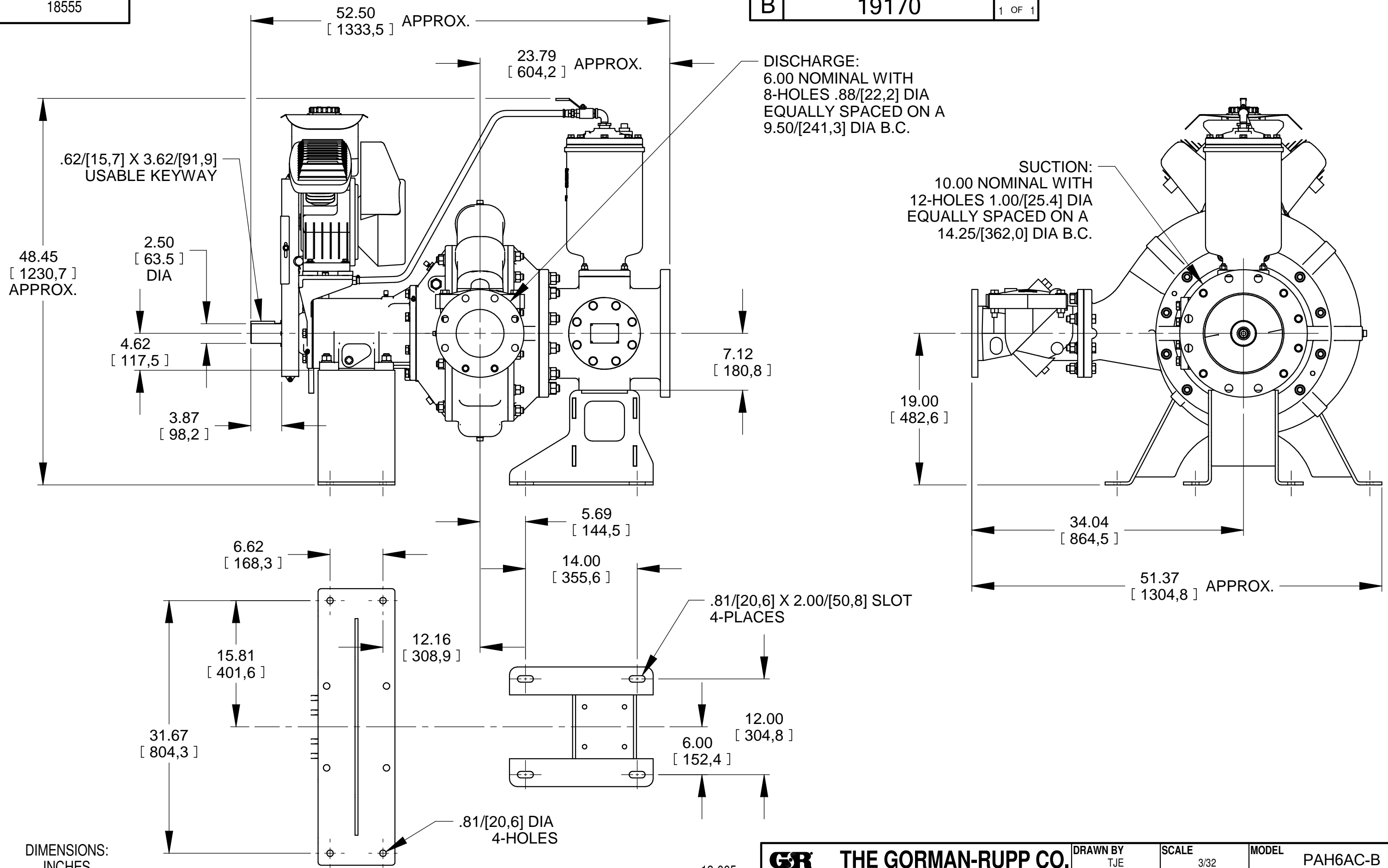

DIMENSIONS:
INCHES
[MILLIMETERS]

18-005

GR GORMAN-RUPP PUMPS	THE GORMAN-RUPP CO.		DRAWN BY	SCALE	MODEL
	MANSFIELD, OHIO	ST. THOMAS, ONTARIO	TJE	3/32	PAH6AC-B
			DATE	REVISED	OUTLINE NUMBER
			8/25/15	8/2/2018	19170