

DISCHARGE:  
4.00 NOMINAL WITH  
8 HOLES .75/[19,0] DIA  
EQUALLY SPACED ON A  
7.50/[190,5] DIA B C

SUCTION:  
6.00 NOMINAL WITH  
8 HOLES .88/[22,4] DIA  
EQUALLY SPACED ON A  
9.50/[241,3] DIA B C

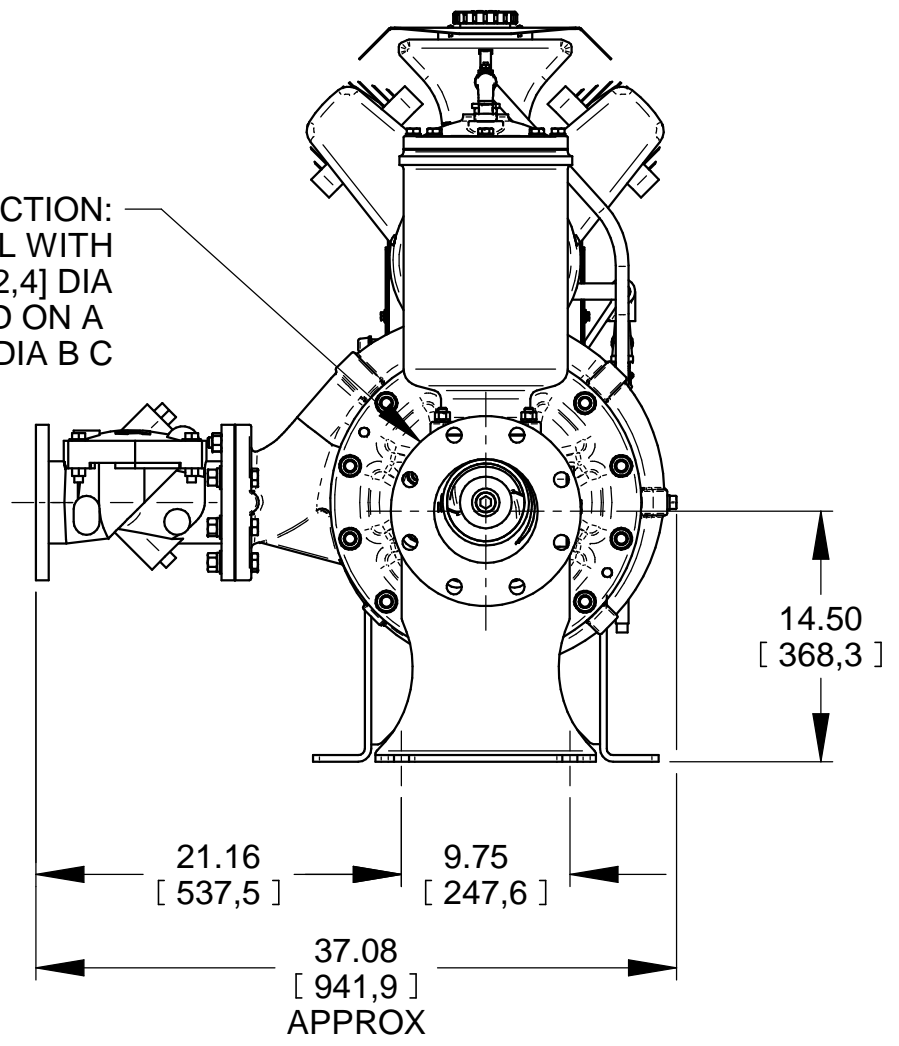

DIMENSIONS:  
INCHES  
[MILLIMETERS]

	<b>THE GORMAN-RUPP CO.</b> MANSFIELD, OHIO ST. THOMAS, ONTARIO		DRAWN BY REP	SCALE 3/32	MODEL PAH4EC-B
	DATE 01/28/2015	REVISED	OUTLINE NUMBER 19088		