

SUCTION:  
10.00 NOMINAL WITH  
12 HOLES 1.00/[25,4] DIA  
EQUALLY SPACED ON A  
14.25/[362,0] DIA. B.C.

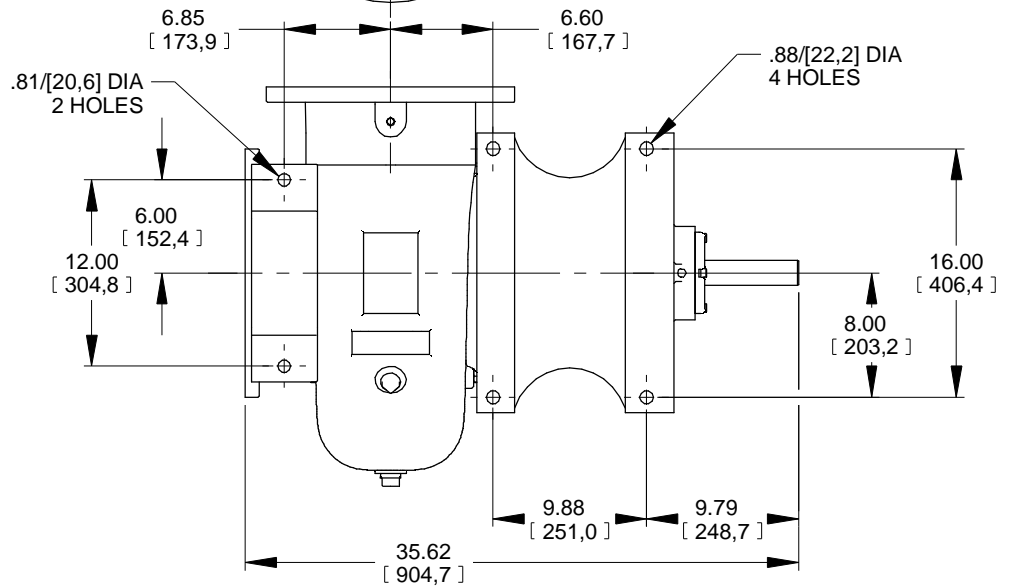
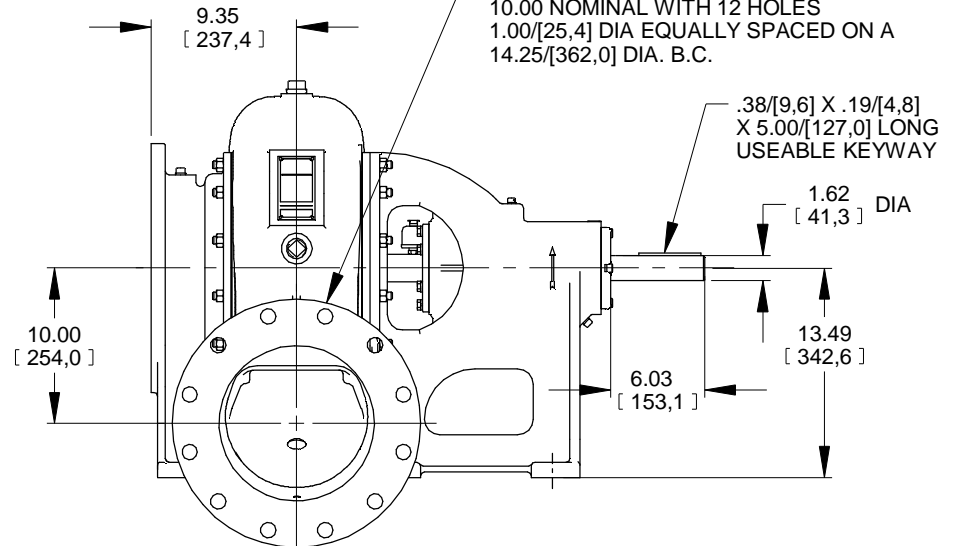

DIMENSIONS:  
INCHES  
[MILLIMETERS]

a	<b>THE GORMAN-RUPP CO.</b>		DRAWN BY	SCALE	MODEL
	MANSFIELD, OHIO	ST. THOMAS, ONTARIO	SAR	1/8	610M-B
			DATE	REVISED	OUTLINE NUMBER
			12-8-14		19070