

DISCHARGE:  
10.00 NOMINAL WITH  
(12) 1.00/[25.4,0] DIA HOLES  
EQUALLY SPACED ON A  
14.25/[362,0] DIA BC

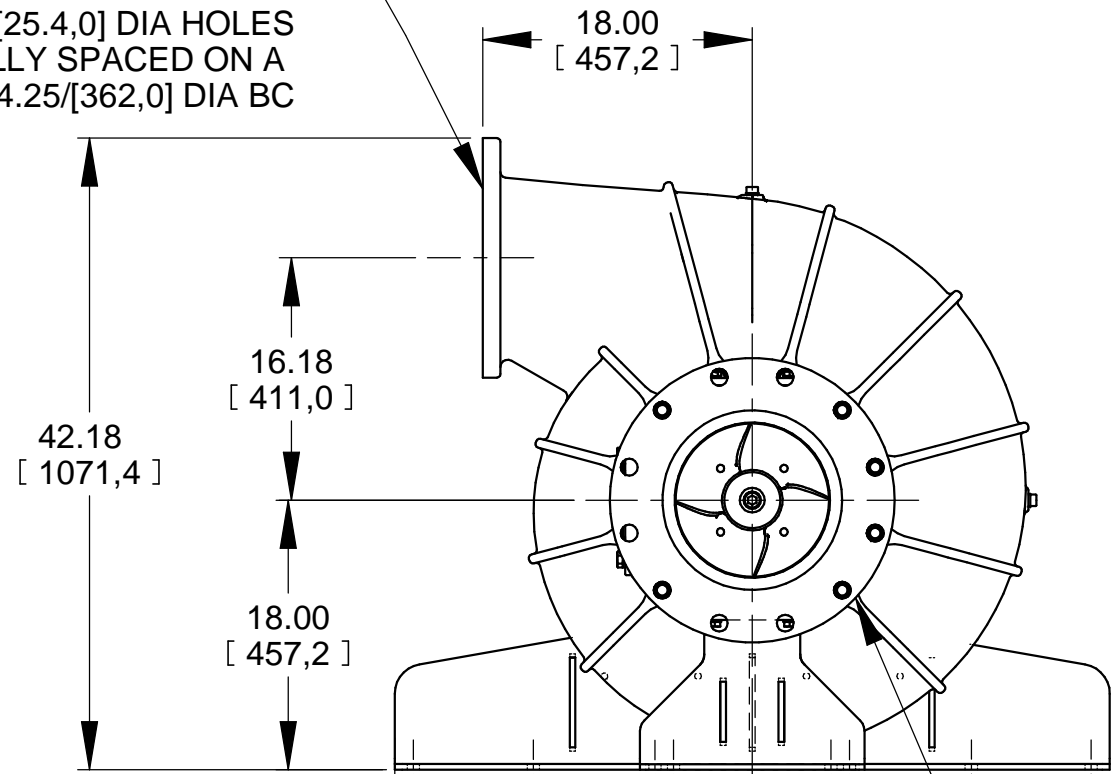

SUCTION :  
12.00 NOMINAL WITH  
(12) 1.00/[25.4] DIA HOLES  
EQUALLY SPACED ON A  
17.00/[431,8] DIA BC

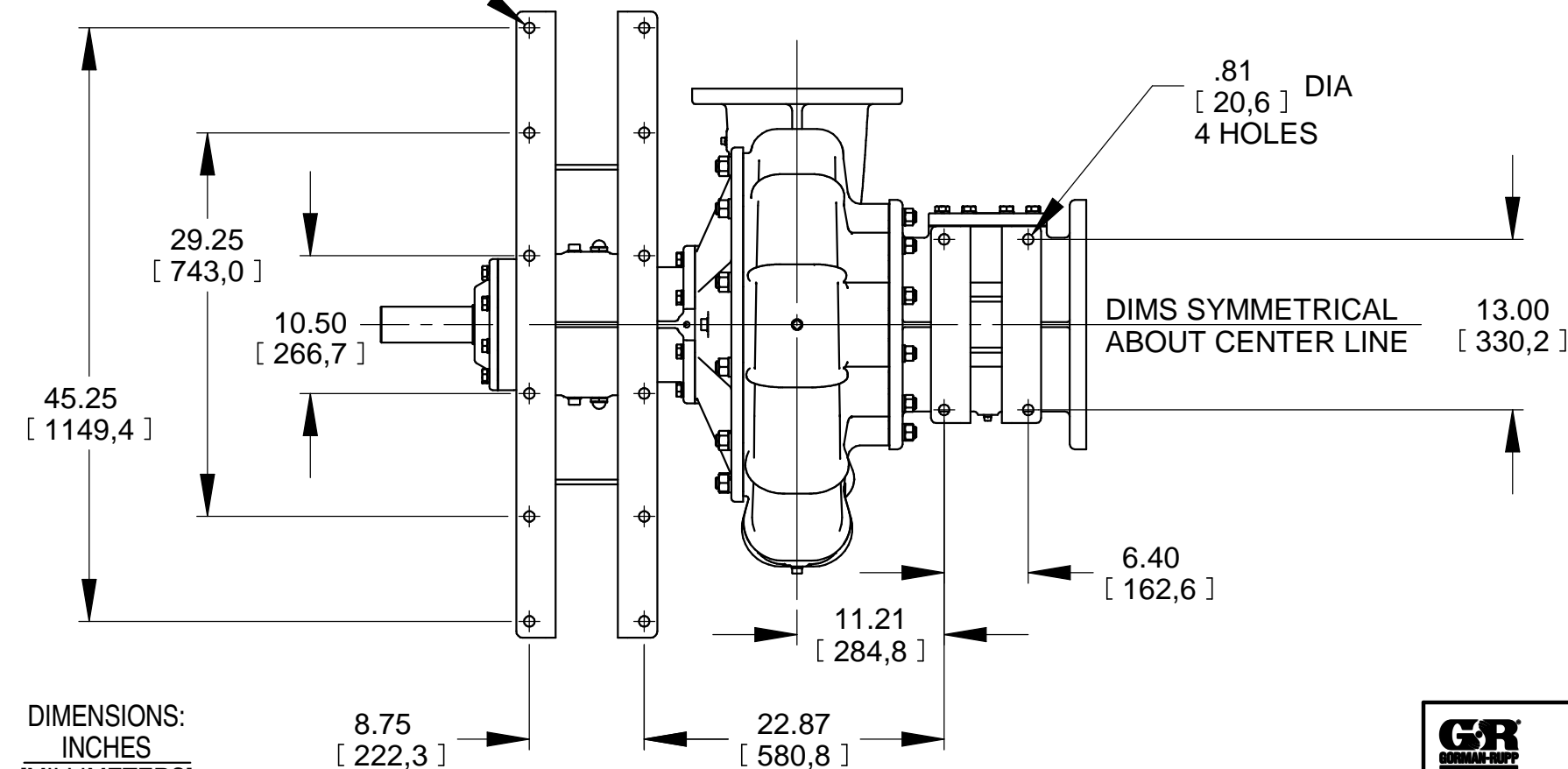

DIMENSIONS:  
INCHES  
[MILLIMETERS]

	<b>THE GORMAN-RUPP CO.</b> MANSFIELD, OHIO ST. THOMAS, ONTARIO		DRAWN BY REP	SCALE 5/64	MODEL 6510A-B
	DATE 11/11/2014	REVISED 4-6-16	OUTLINE NUMBER 19039		