

DISCHARGE:
16.00 NOMINAL WITH
(16) 1.12/[28,6] DIA HOLES
EQUALLY SPACED ON A
21.25/[539,8] DIA B.C.

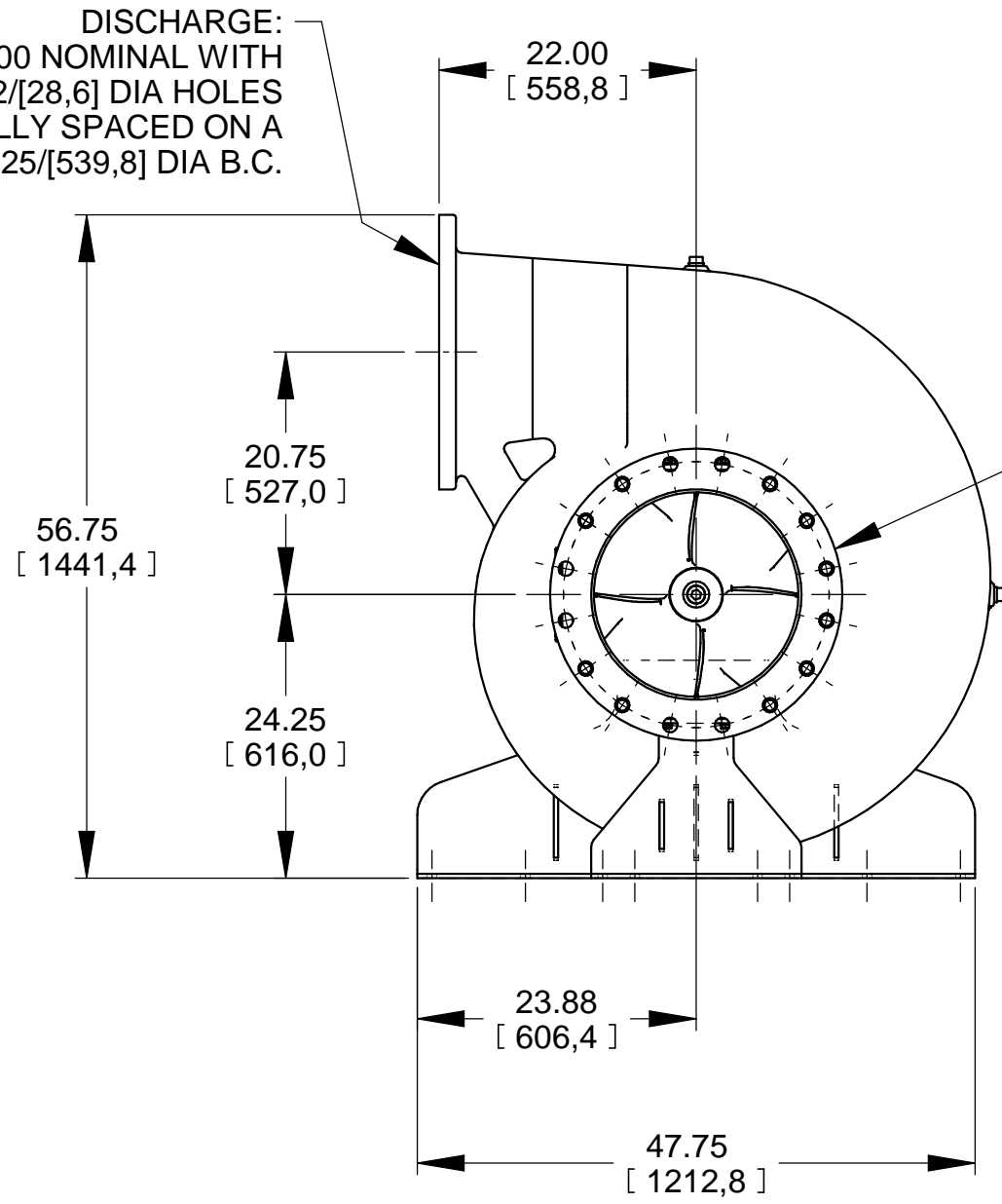

SUCTION:
18.00 NOMINAL WITH
(16) 1.25/[31,8] DIA HOLES
EQUALLY SPACED ON A
22.75/[577,8] DIA B.C.

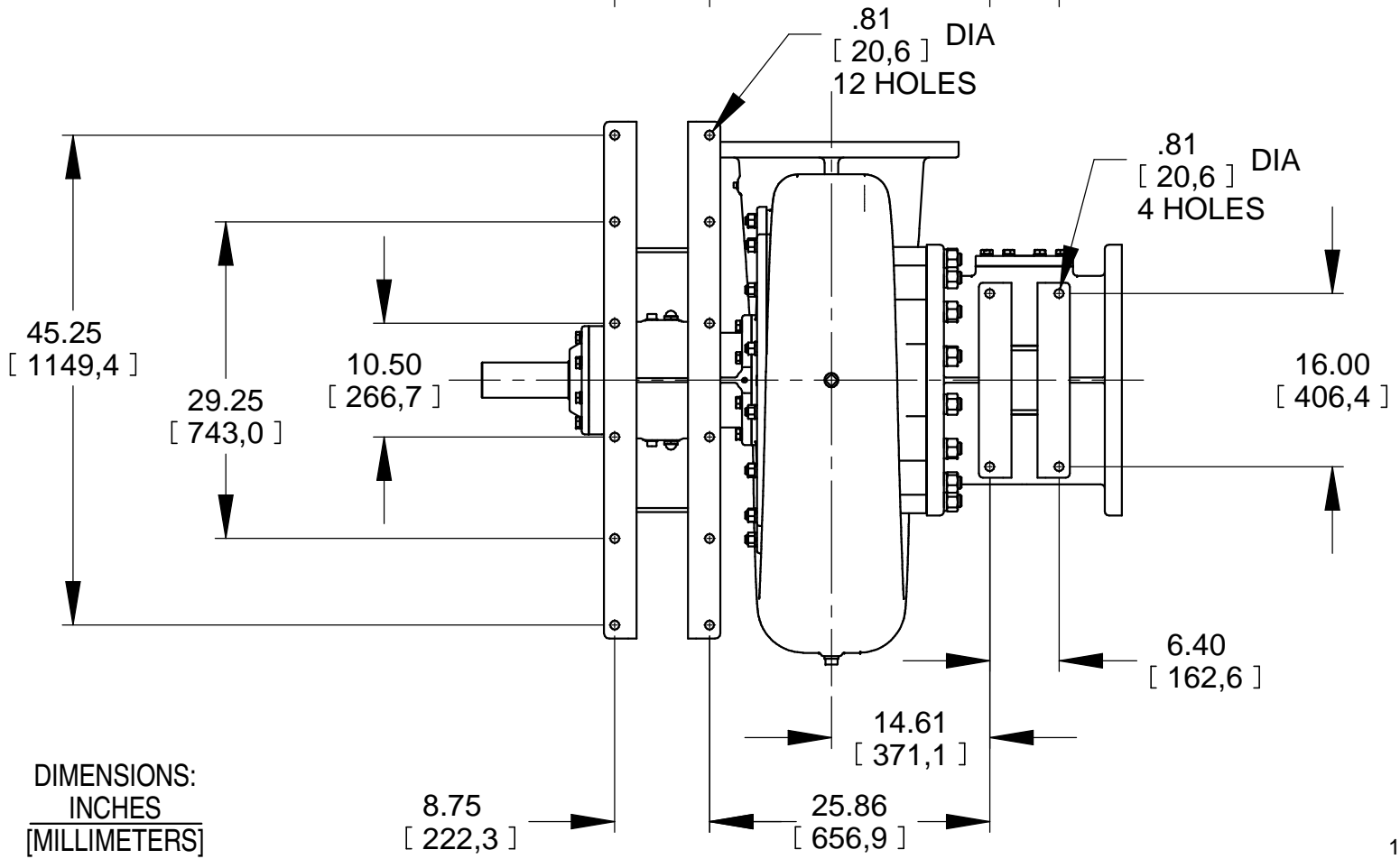

DIMENSIONS:
INCHES
[MILLIMETERS]

	THE GORMAN-RUPP CO. MANSFIELD, OHIO ST. THOMAS, ONTARIO		DRAWN BY REP	SCALE 1:16	MODEL 6516A-B
	DATE 11/11/14	REVISED 04/07/16	OUTLINE NUMBER 19038		

16-027