

DISCHARGE:
4.00 NOMINAL WITH 8-HOLES EQUALLY
SPACED ON A 7.50/[190,5] DIA B. C. WITH
6-HOLES .75/[19,0] DIA THRU, TOP TWO HOLES
TAPPED .625-11 UNC-2B THRU

SUCTION:
6.00 NOMINAL WITH
8-HOLES .88/[22,2] DIA
EQUALLY SPACED ON A
9.50/[241,3] DIA B. C.

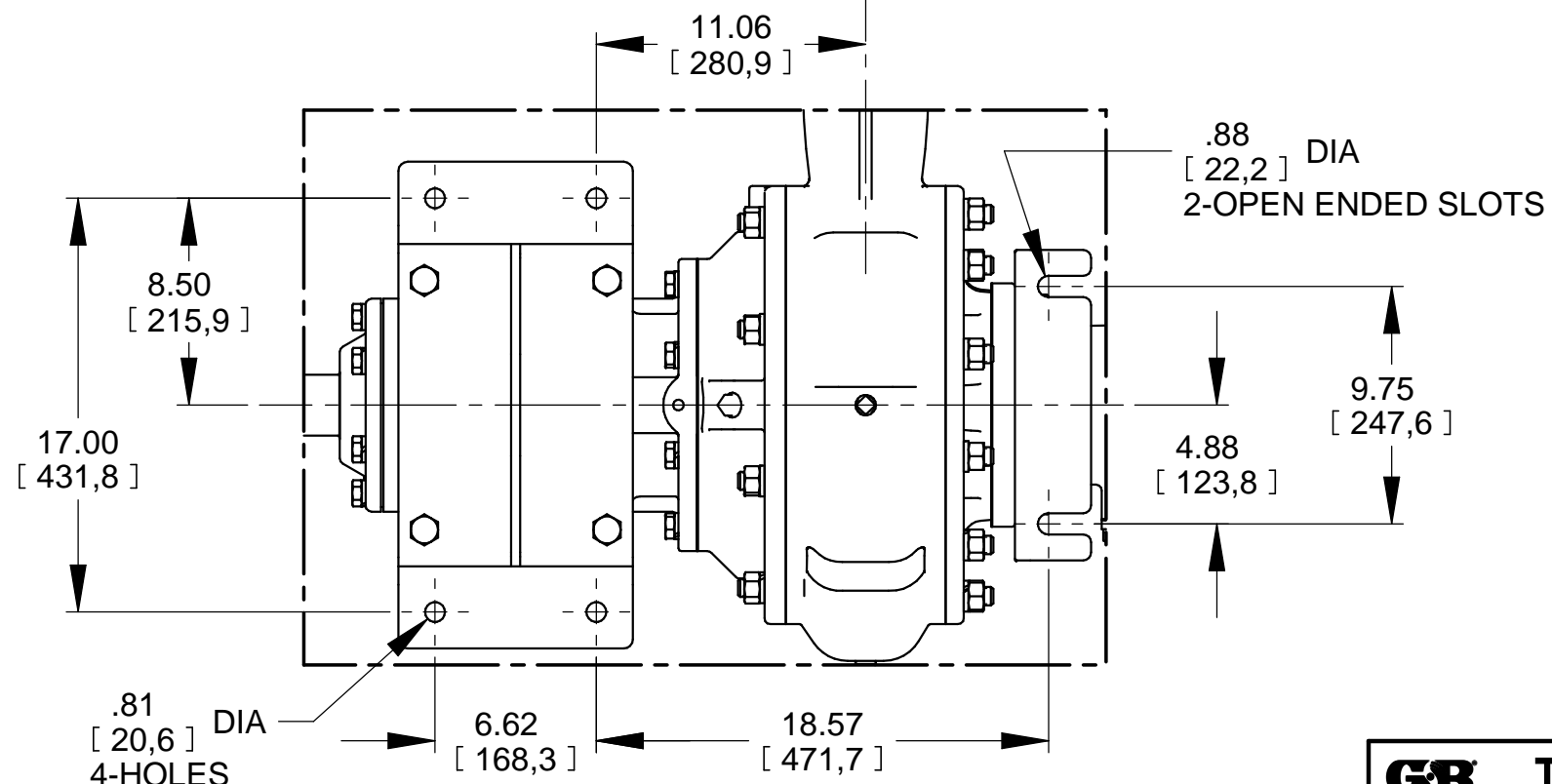

DIMENSIONS:
INCHES
[MILLIMETERS]

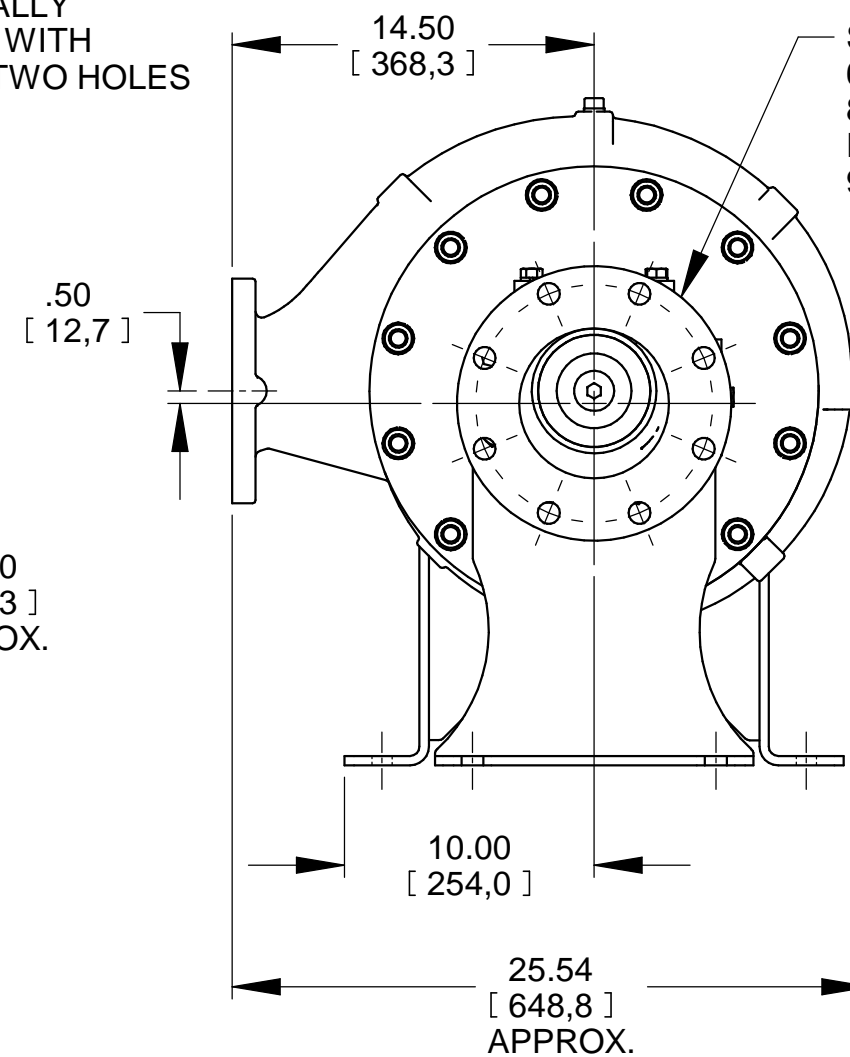
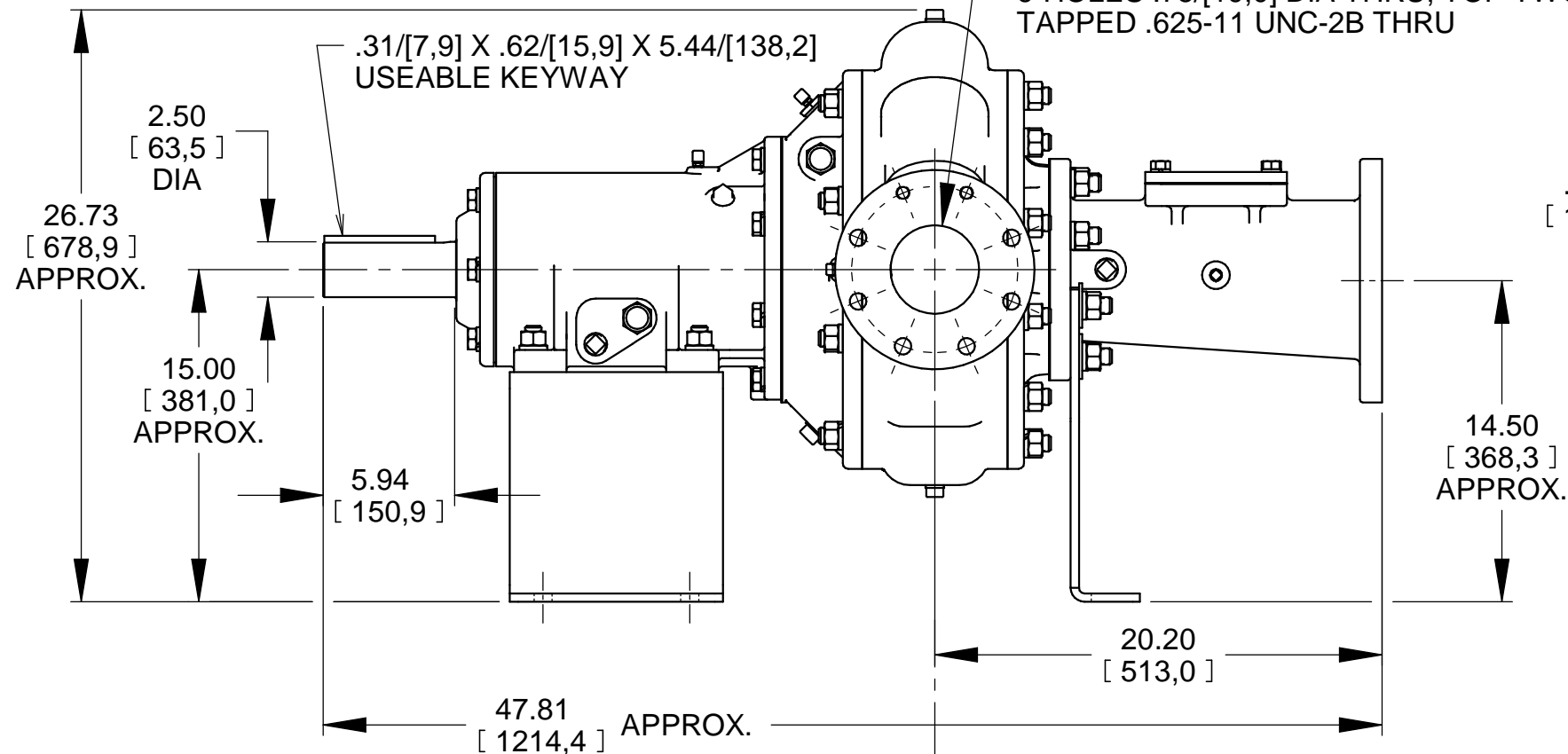

THE GORMAN-RUPP CO.
MANSFIELD, OHIO ST. THOMAS, ONTARIO

DRAWN BY
JPJ
DATE
9-24-14

SCALE
1/8
REVISED
6-9-15

MODEL
6504E-B
OUTLINE NUMBER
19014