

DISCHARGE:  
16.00 NOMINAL WITH (16) 1.12/[28,6] DIA HOLES  
EQUALLY SPACED ON A 21.25/[539,8] DIA BC

SUCTION:  
18.00 NOMINAL WITH (16) 1.25/[31,8] DIA HOLES  
EQUALLY SPACED ON A 22.75/[577,8] DIA BC

.75/[19,1] X .37/[9,4] X 7.37/[187,2] LG  
USEABLE KEYWAY

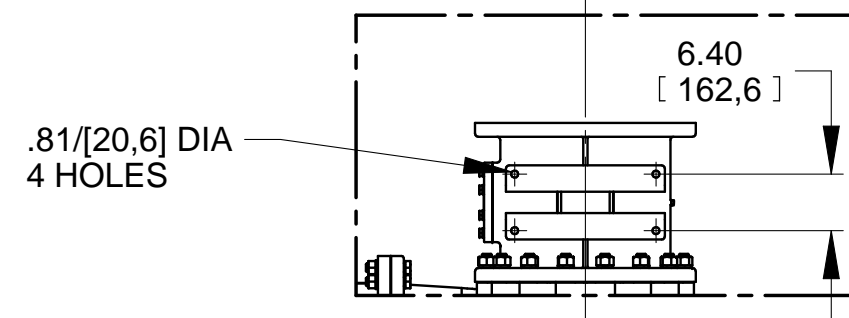
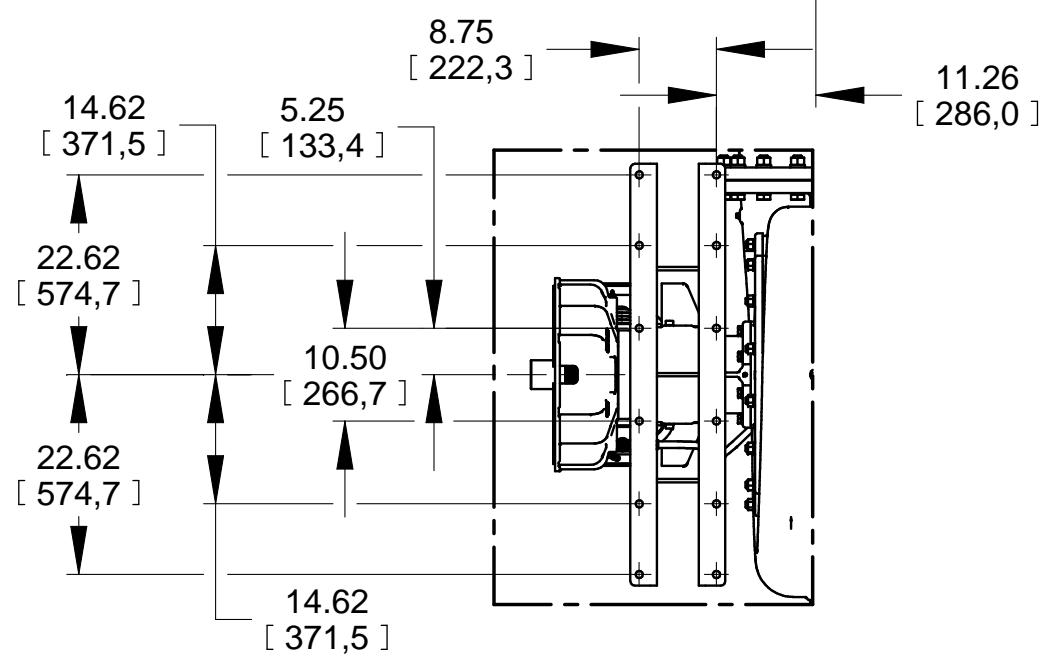
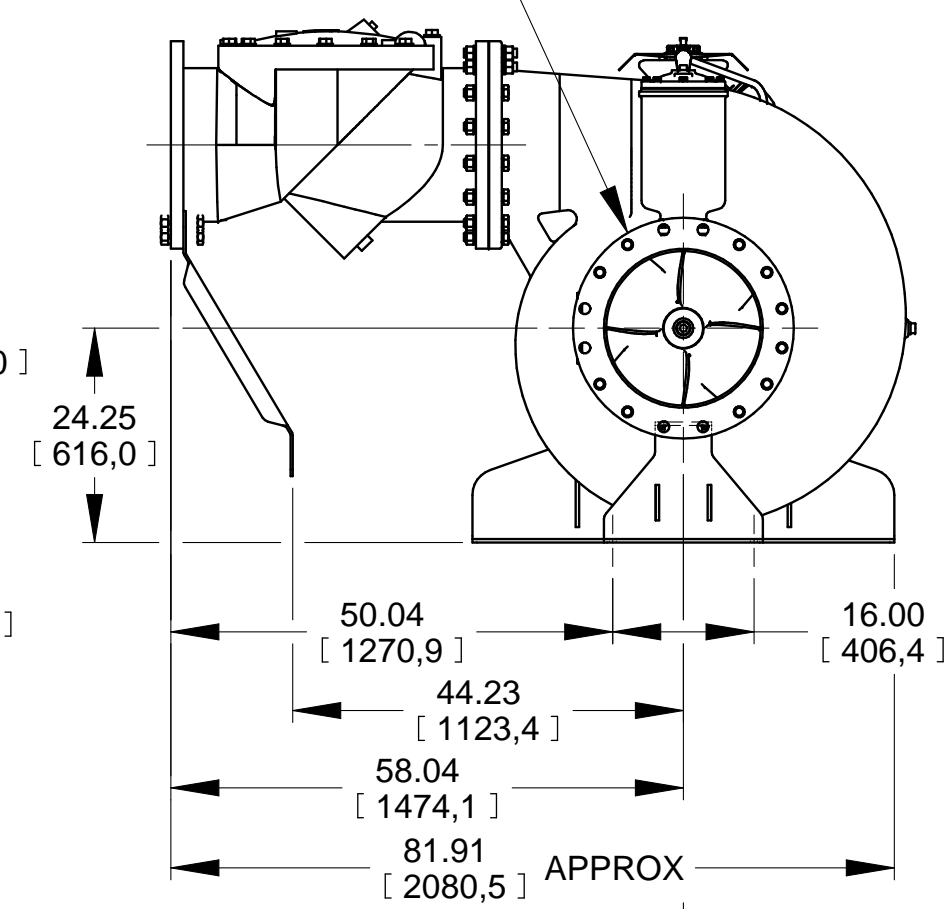
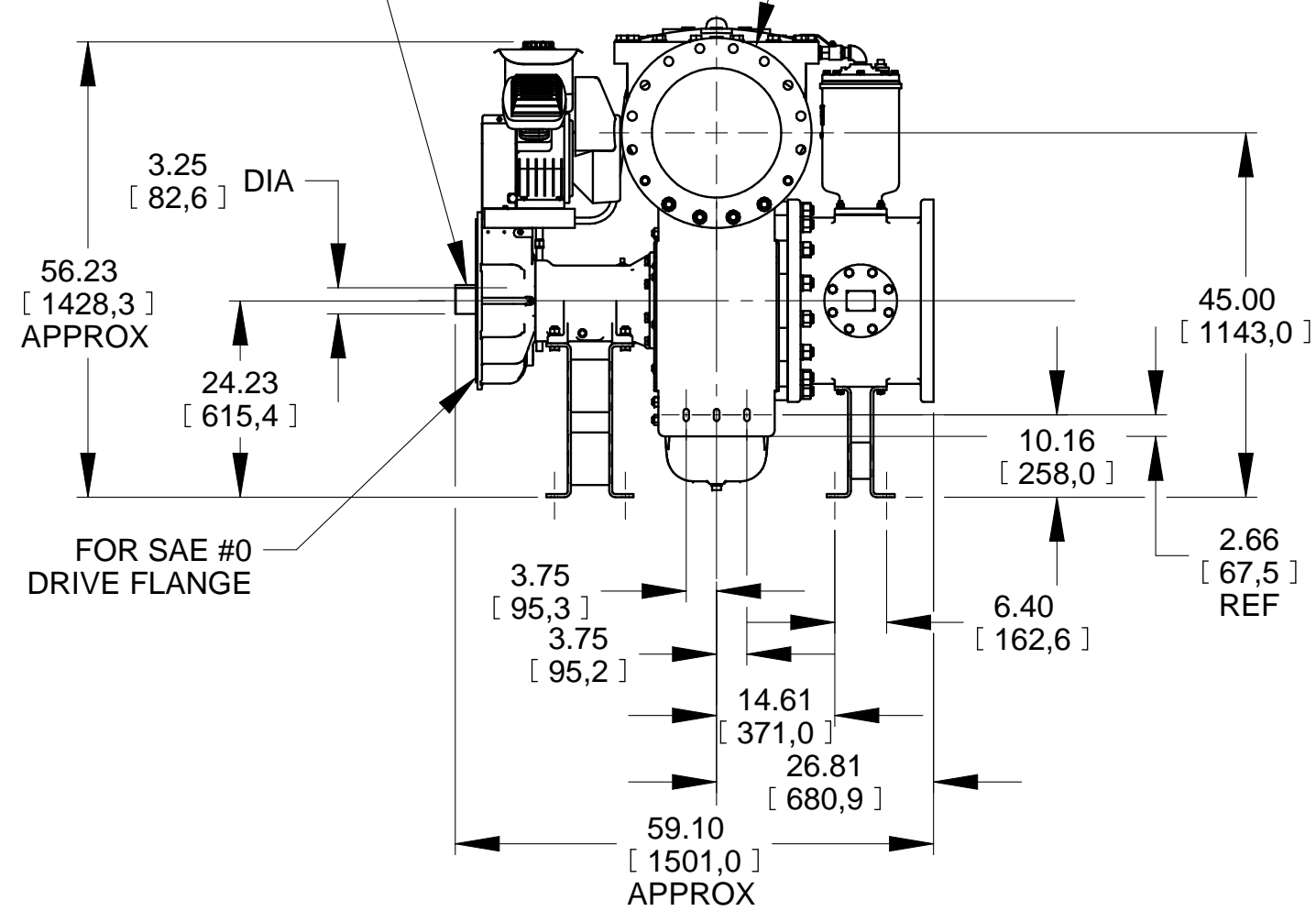

DIMENSIONS:  
INCHES  
[MILLIMETERS]

23-018

	<b>THE GORMAN-RUPP CO.</b> MANSFIELD, OHIO ST. THOMAS, ONTARIO		DRAWN BY MLB	SCALE 3/64	MODEL PAH16A60C-B
	DATE 03-21-14	REVISED 7-14-23	OUTLINE NUMBER 18939		