

\* 18.00/[457.2] RECOMMENDED FOR REMOVAL OF BACK COVER PLATE

10.50/[266.7] REQUIRED FOR REMOVAL OF BACK COVER PLATE

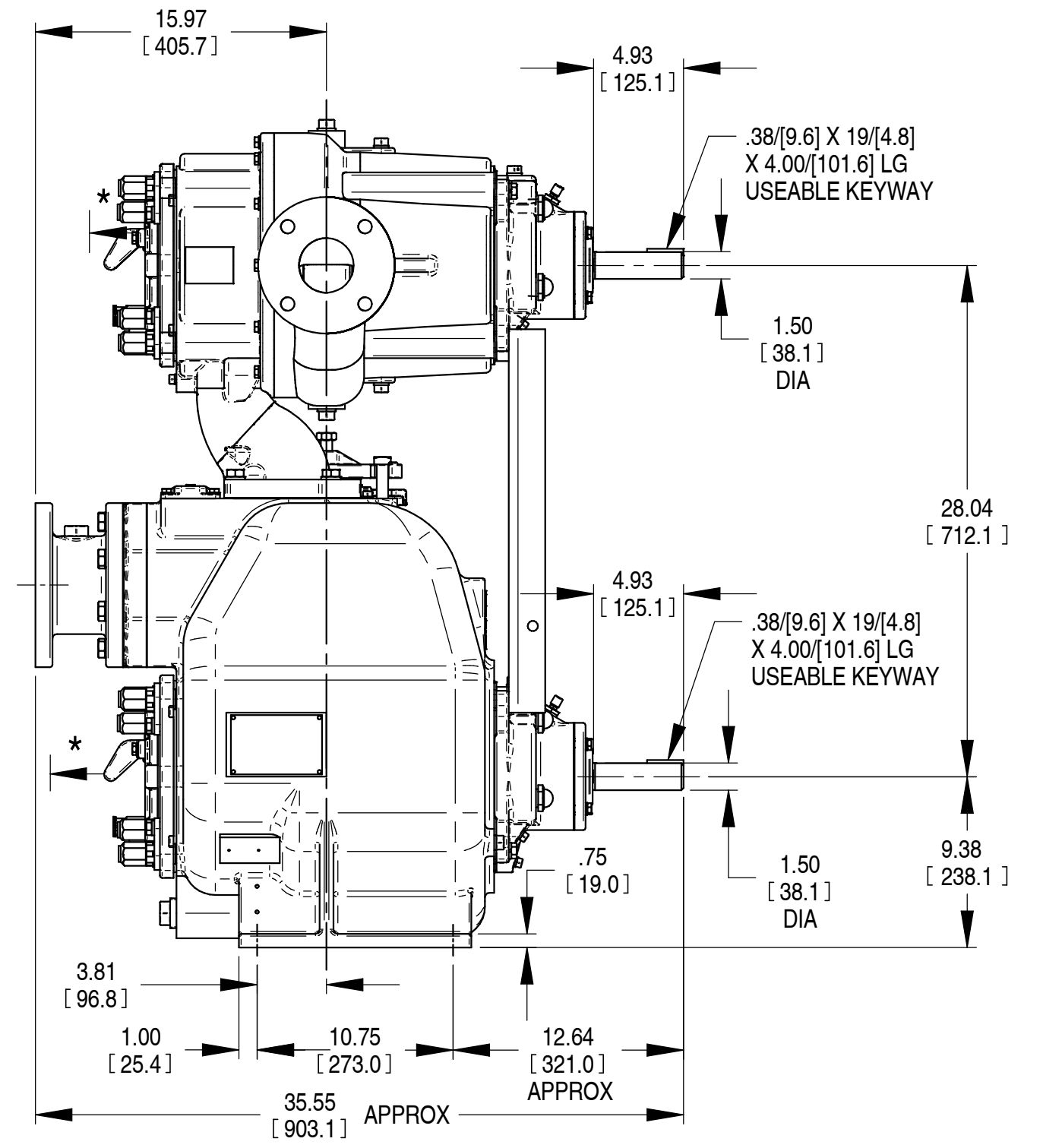
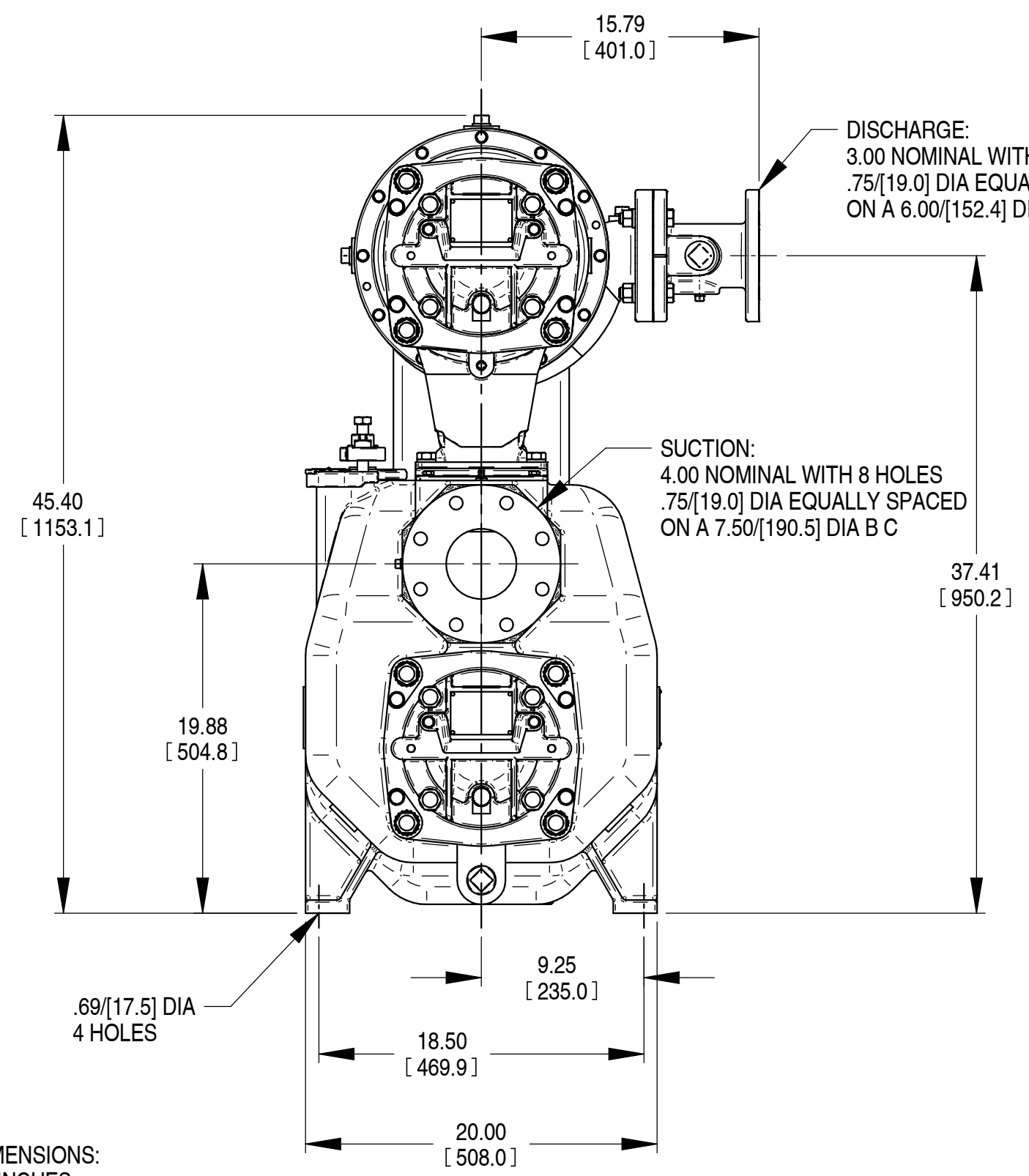

SHOWN WITH OPTIONAL 4" X 3" STAGED SUCTION/DISCHARGE SPOOL FLANGE KIT

DIMENSIONS:  
INCHES  
[MILLIMETERS]

20-008

	<b>THE GORMAN-RUPP CO.</b> MANSFIELD, OHIO ST. THOMAS, ONTARIO		DRAWN BY REP	SCALE 1/8	MODEL VS3A-B / VS3B-B
	DATE 07/19/06	REVISED 7/7/2020	OUTLINE NUMBER <b>18069</b>		