

* 18.00/[457.2] RECOMMENDED FOR REMOVAL OF BACK COVER PLATE

10.50/[266.7] REQUIRED FOR REMOVAL OF BACK COVER PLATE

B 18068

SHEET
1 OF 1

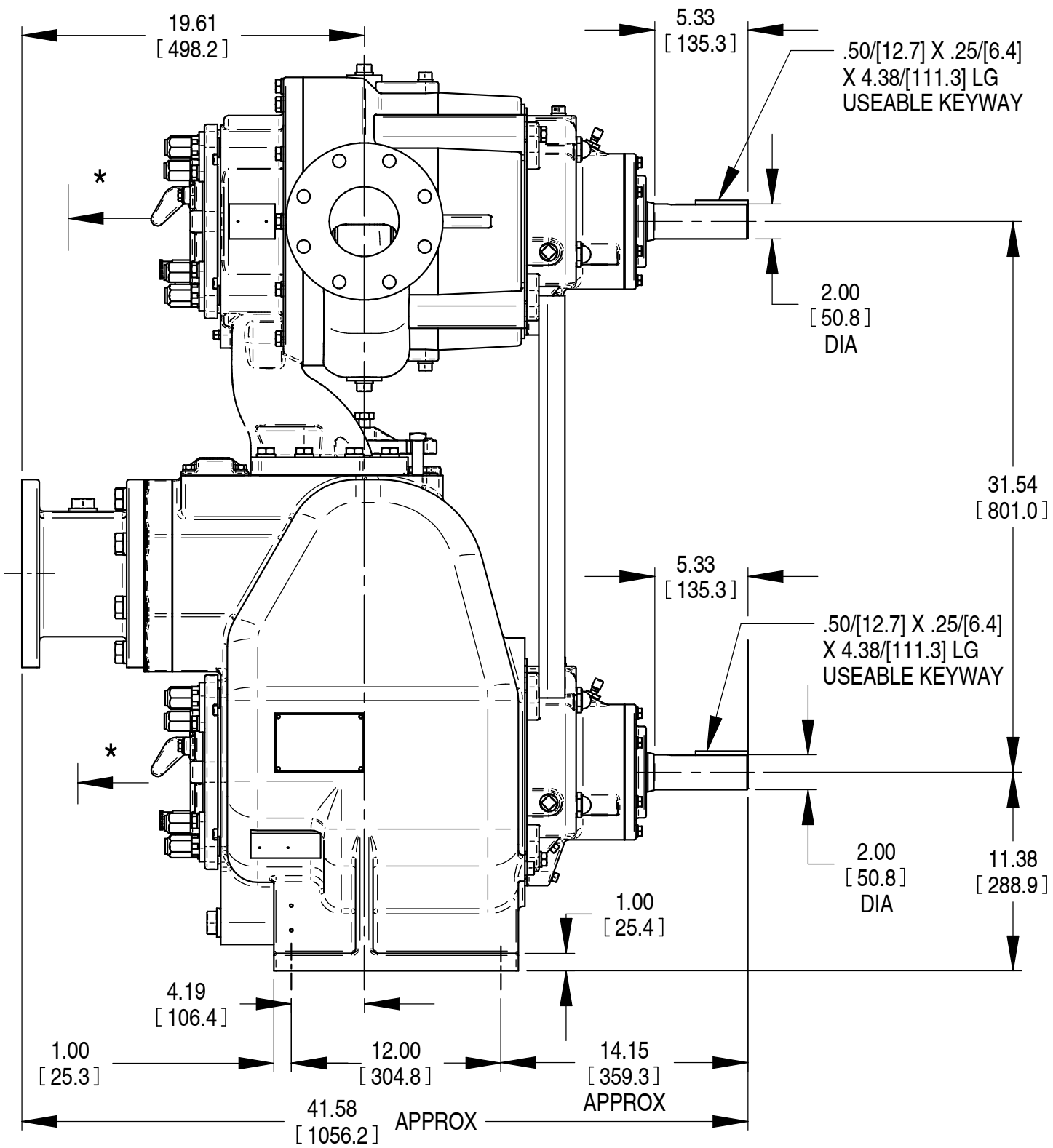
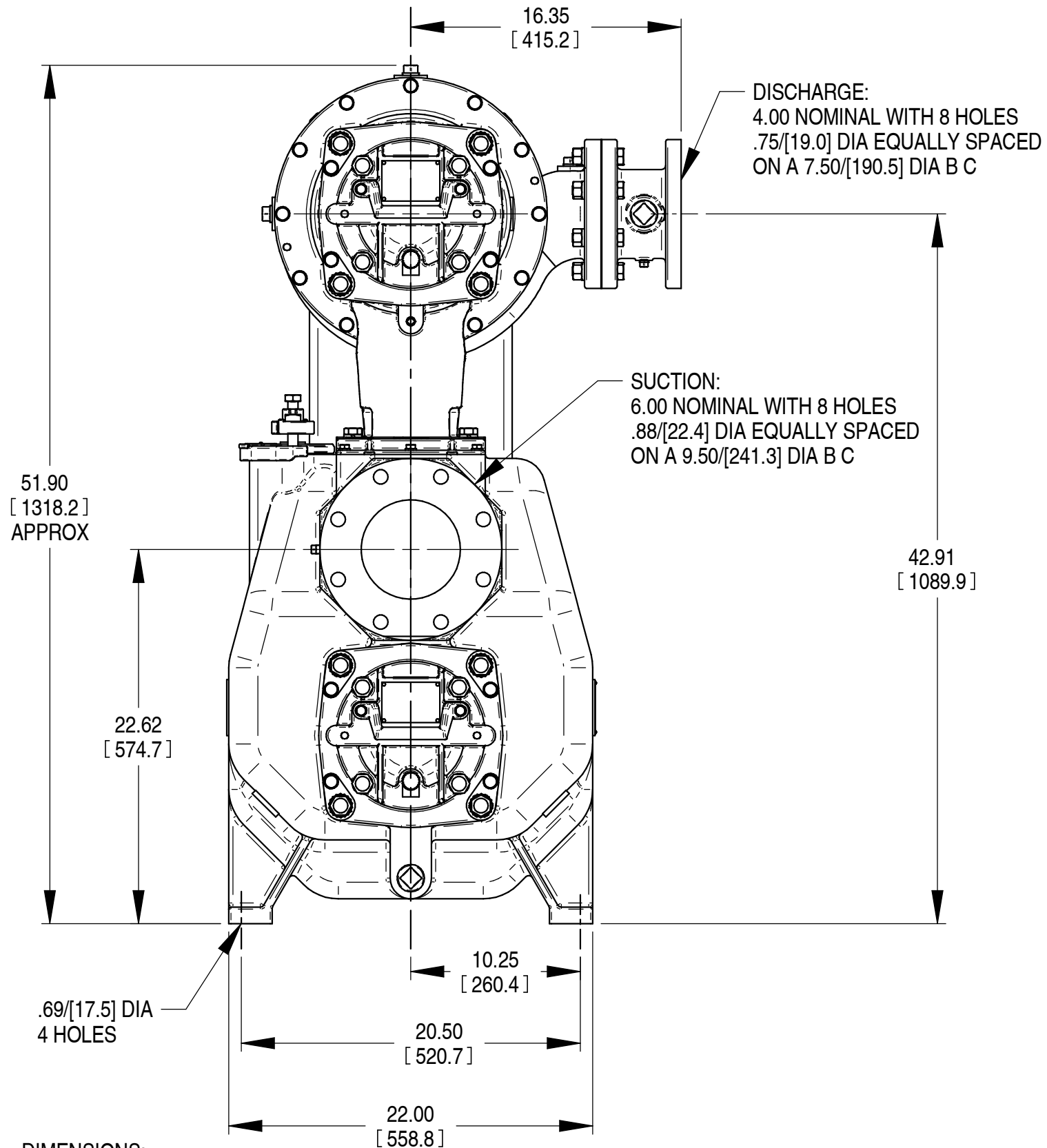

SHOWN WITH OPTIONAL 6" X 4" STAGED SUCTION/DISCHARGE SPOOLFLANGE KIT

DIMENSIONS:
INCHES
[MILLIMETERS]

20-008



THE GORMAN-RUPP CO.
MANSFIELD, OHIO ST. THOMAS, ONTARIO

DRAWN BY
REP
DATE
07/18/06

SCALE
1/8
REVISED
8/20/2020

MODEL
VS4A-B
OUTLINE NUMBER
18068