

* 24.00/[609,6] RECOMMENDED FOR REMOVAL OF BACK COVER PLATE
 14.00/[355,6] REQUIRED FOR REMOVAL OF BACK COVER PLATE

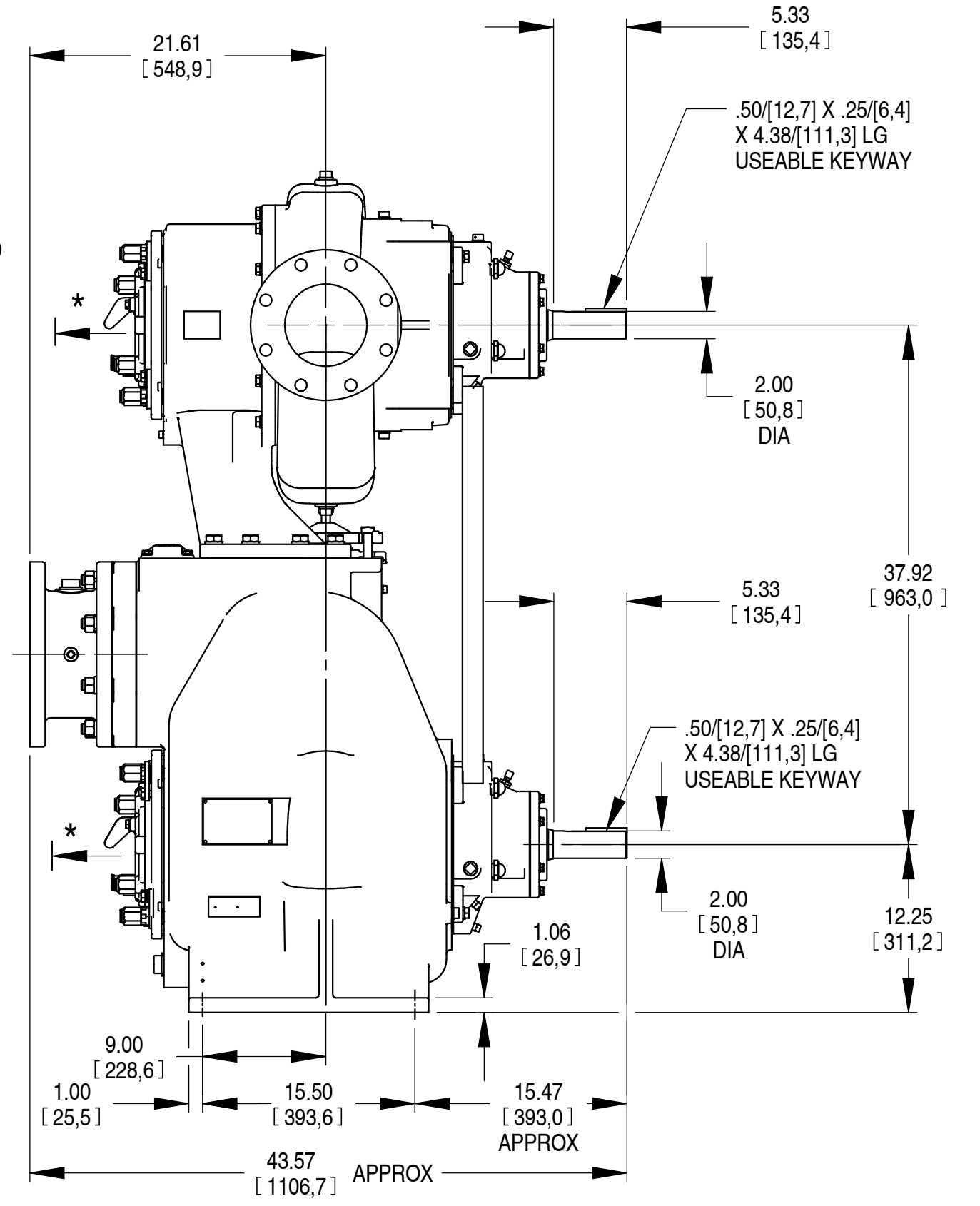
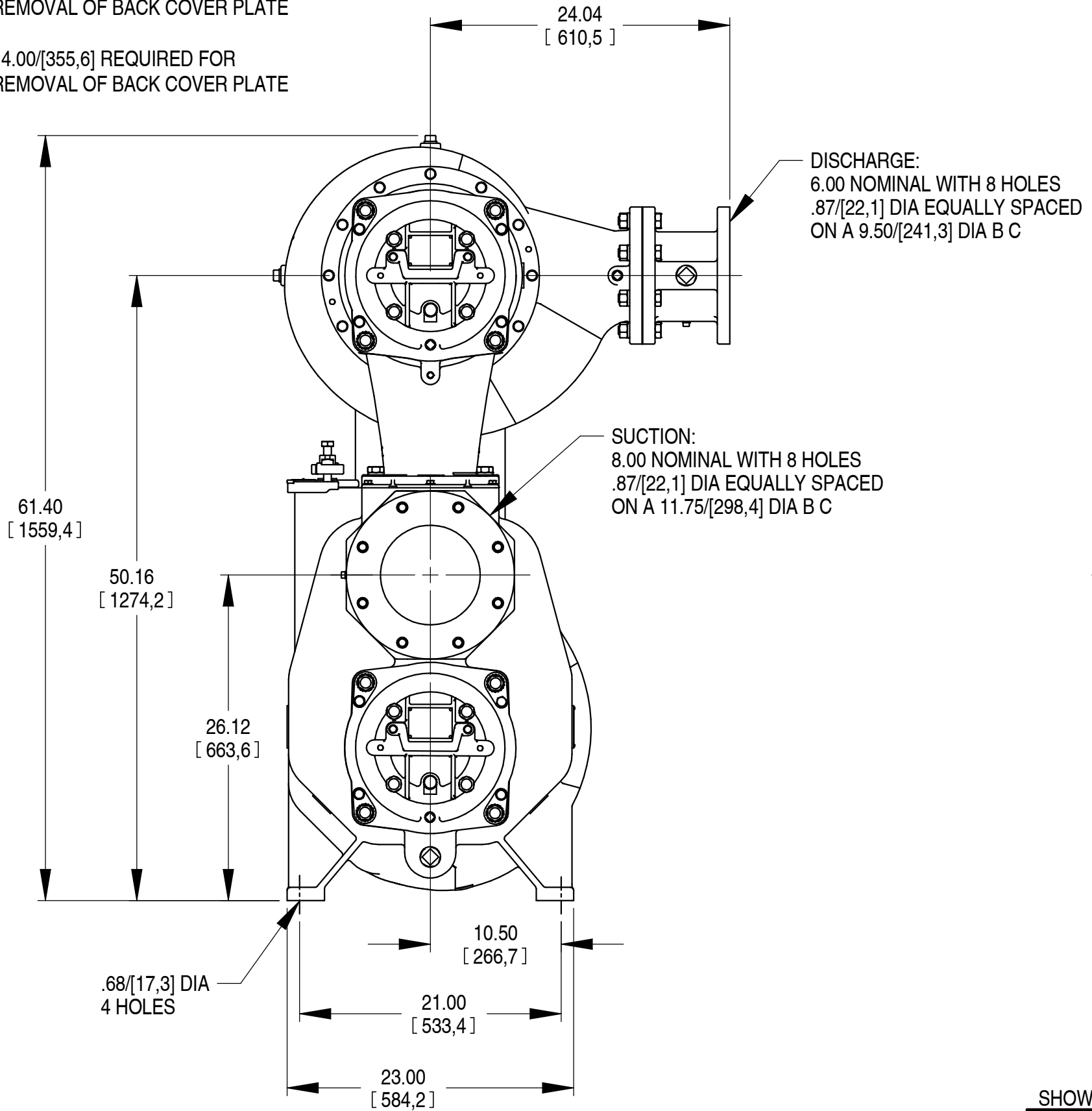

DIMENSIONS:
 INCHES
 [MILLIMETERS]

SHOWN WITH OPTIONAL 8" X 6" STAGED SUCTION/DISCHARGE SPOOL FLANGE KIT

	THE GORMAN-RUPP CO. MANSFIELD, OHIO ST. THOMAS, ONTARIO		DRAWN BY REP	SCALE 1:10	MODEL VS6A-B
	DATE 07/17/06	REVISED 10/24/18	OUTLINE NUMBER 18067		