

*18.00/[457.2] RECOMMENDED FOR
REMOVAL OF BACK COVER PLATE

10.50/[266.7] REQUIRED FOR
REMOVAL OF BACK COVER PLATE

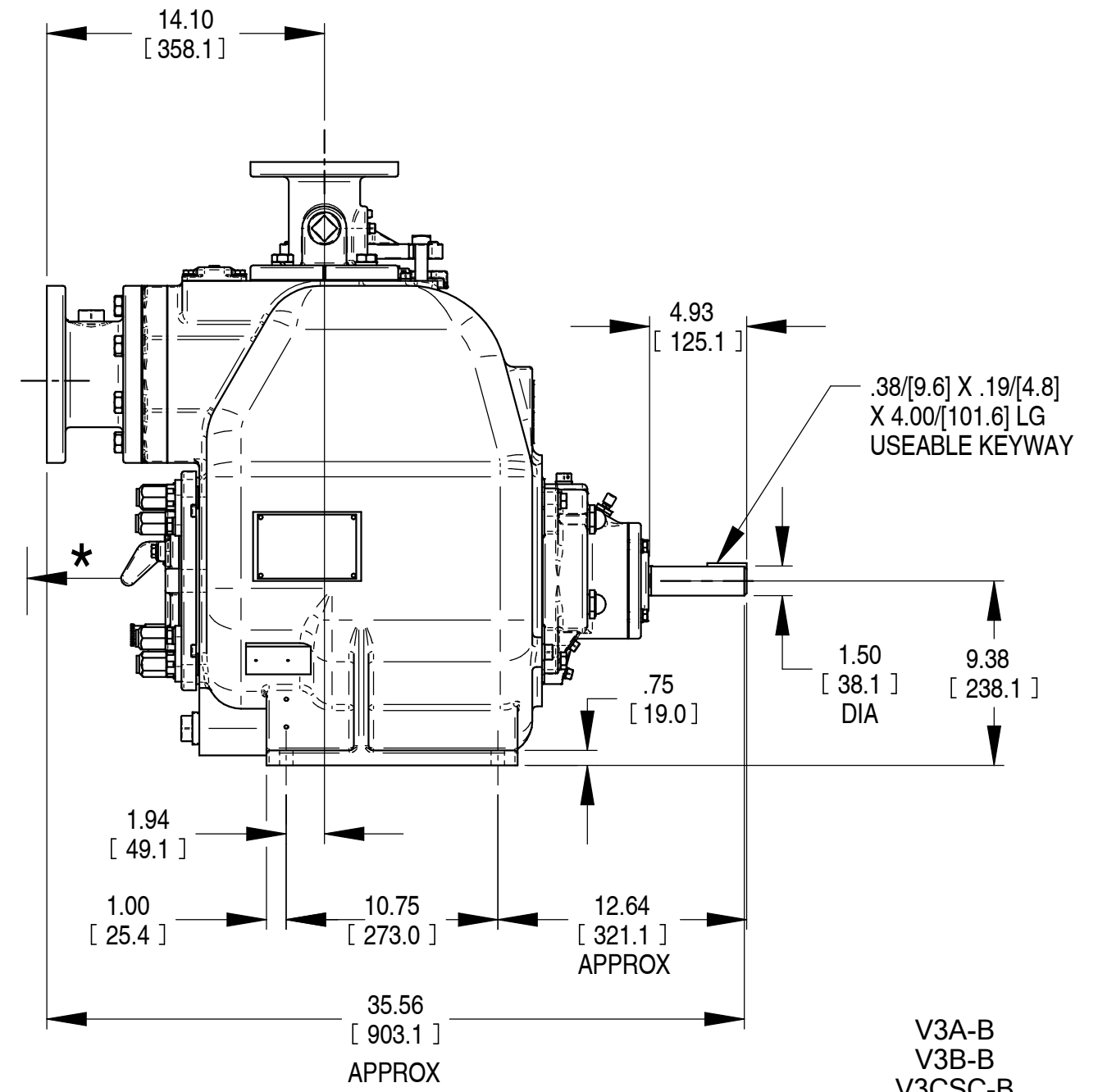
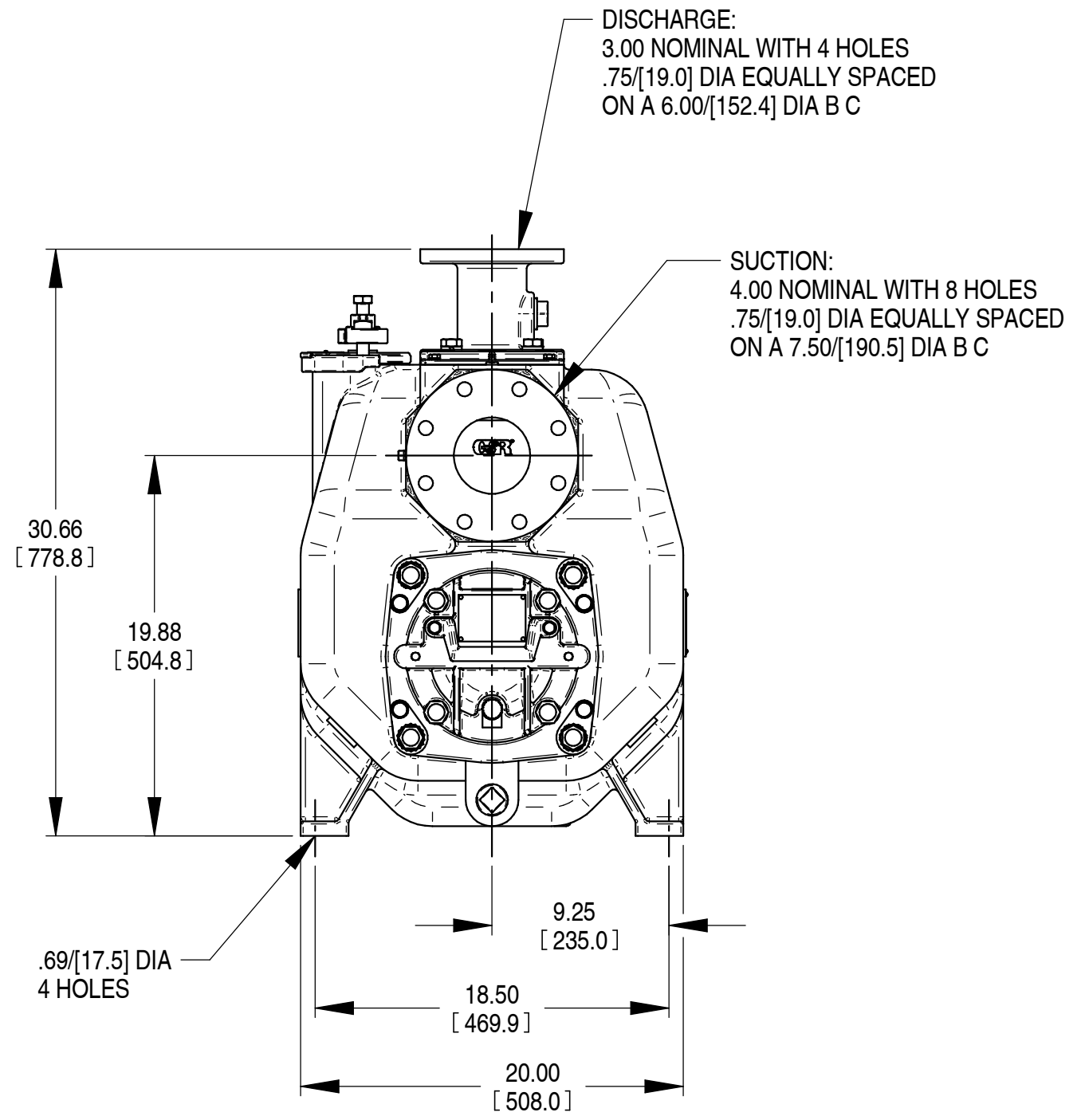

V3A-B
V3B-B
V3CSC-B
V3DSC-B

SHOWN WITH OPTIONAL 4" X 3" SUCTION / DISCHARGE SPOOL KIT

DIMENSIONS:
INCHES
[MILLIMETERS]

20-008

	THE GORMAN-RUPP CO. MANSFIELD, OHIO ST. THOMAS, ONTARIO		DRAWN BY REP	SCALE 1/8	MODEL NOTED
	DATE 4/7/06	REVISED 5/26/2020	OUTLINE NUMBER 18037		