

* 24.00/[609,6] RECOMMENDED FOR
REMOVAL OF BACK COVER PLATE

14.00/[355,6] REQUIRED FOR
REMOVAL OF BACK COVER PLATE

DISCHARGE:
6.00 NOMINAL WITH 8 HOLES
.87/[22,1] DIA EQUALLY SPACED
ON A 9.50/[241,3] DIA B C

SUCTION:
8.00 NOMINAL WITH 8 HOLES
.87/[22,1] DIA EQUALLY SPACED
ON A 11.75/[298,4] DIA B C

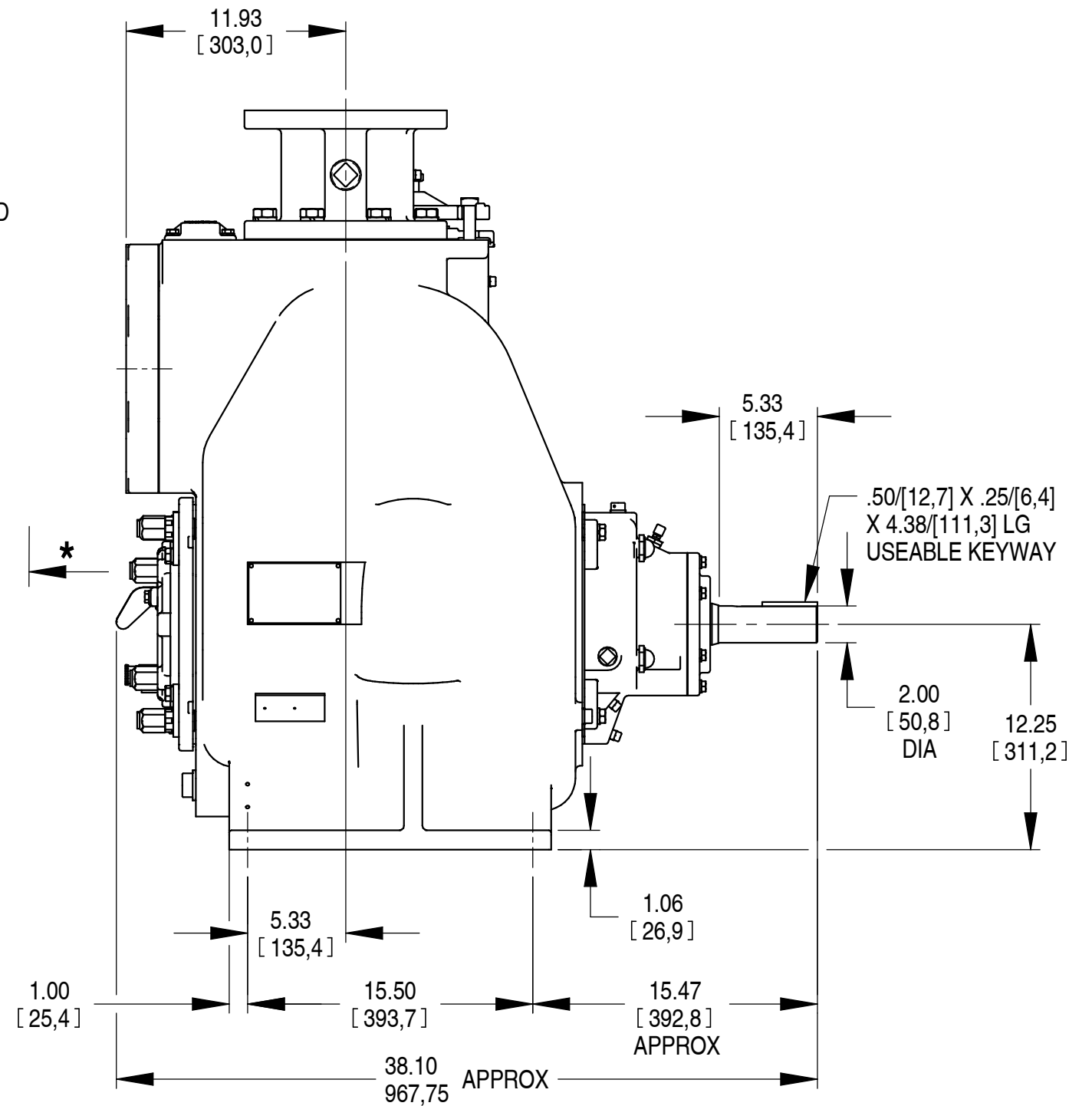
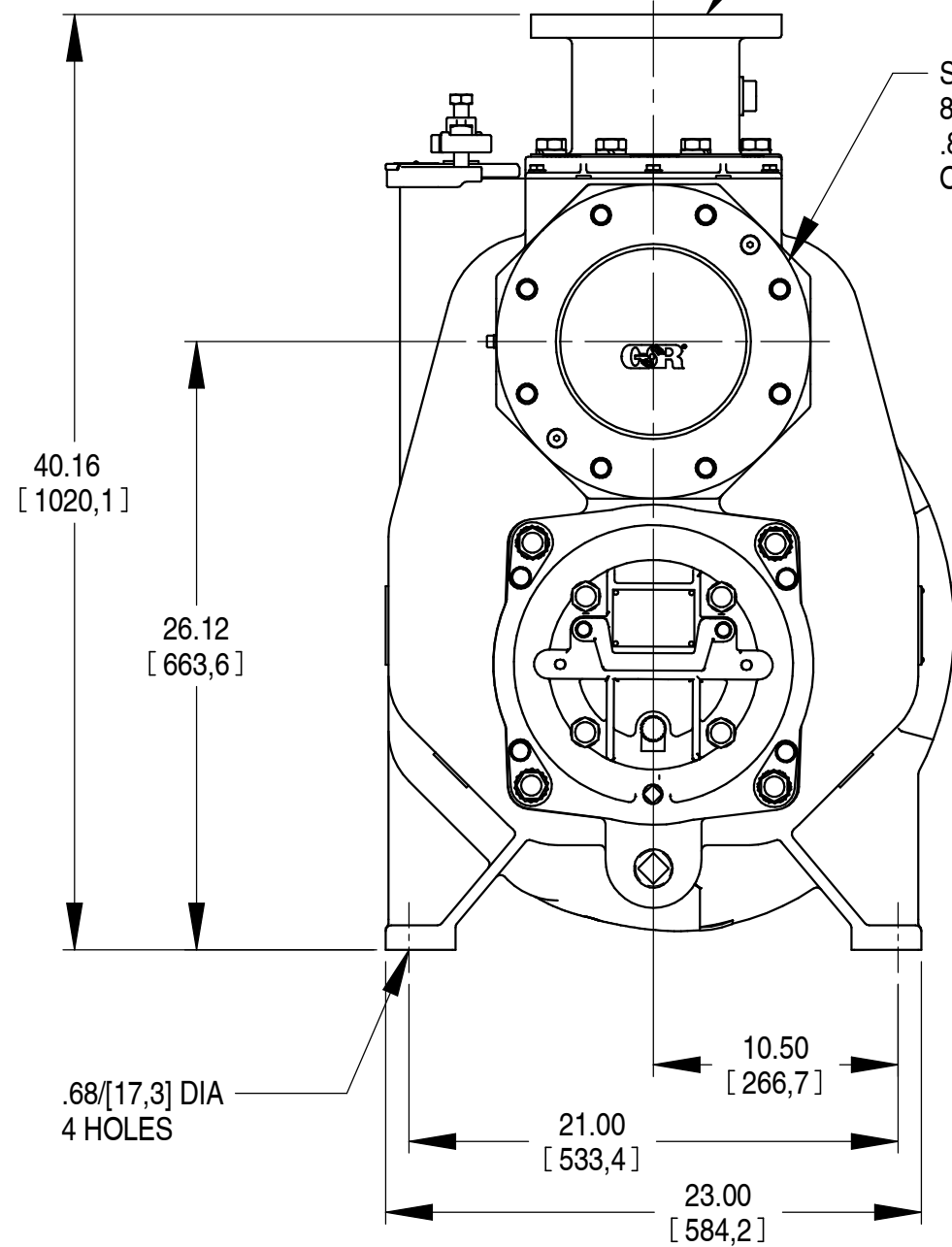

NOTE:
SHOWN WITH OPTIONAL DISCHARGE SPOOL FLANGE

DIMENSIONS:
INCHES
[MILLIMETERS]

18-049



THE GORMAN-RUPP CO.
MANSFIELD, OHIO ST. THOMAS, ONTARIO

DRAWN BY
DFB
DATE
5/19/2005

SCALE
3/32
REVISED
10-24-18

MODEL
V6A-B / V6CSC-B
OUTLINE NUMBER
17870