

* 18.00/[457.2] RECOMMENDED FOR REMOVAL OF BACK COVER PLATE
10.50/[266.7] REQUIRED FOR REMOVAL OF BACK COVER PLATE

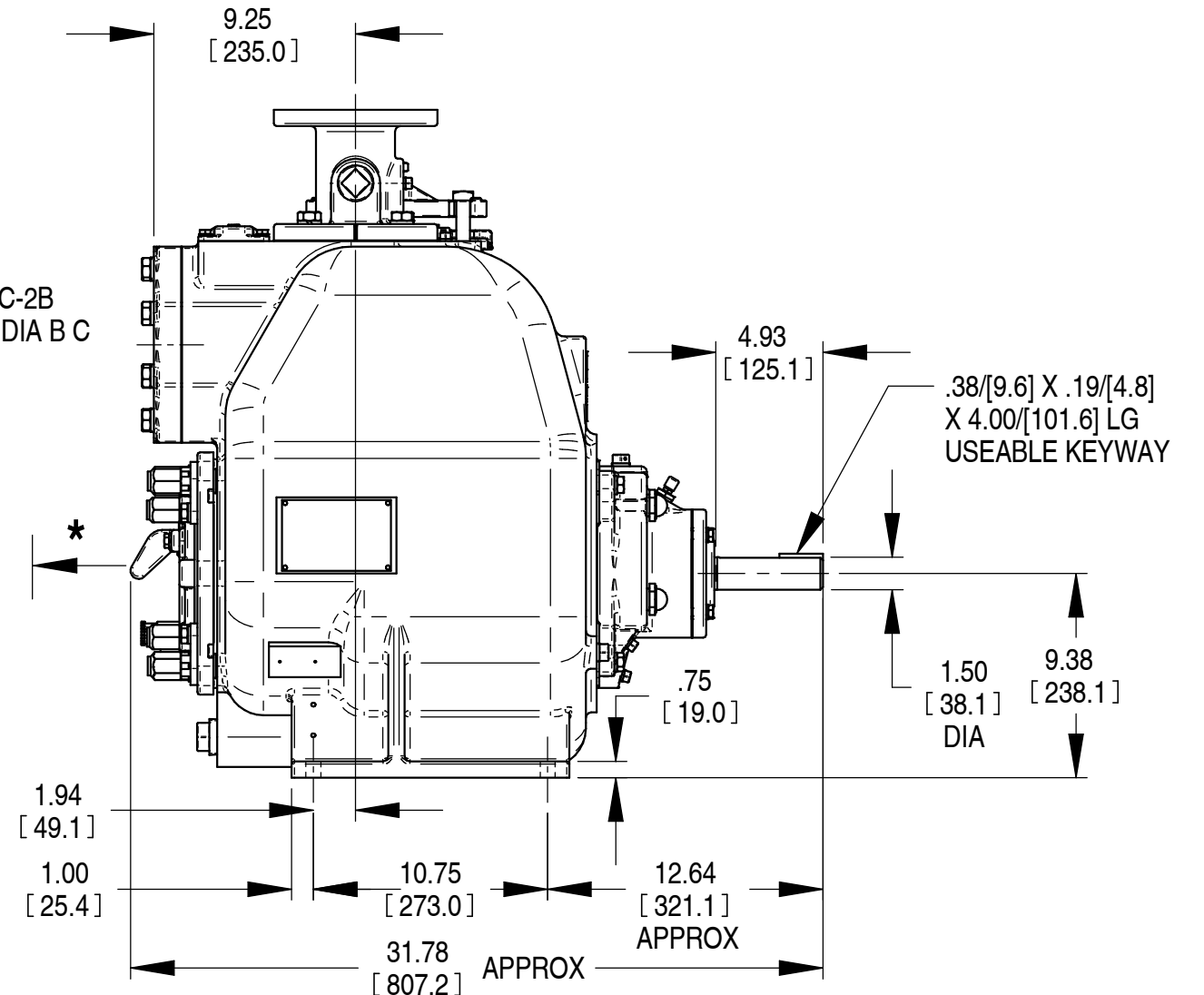
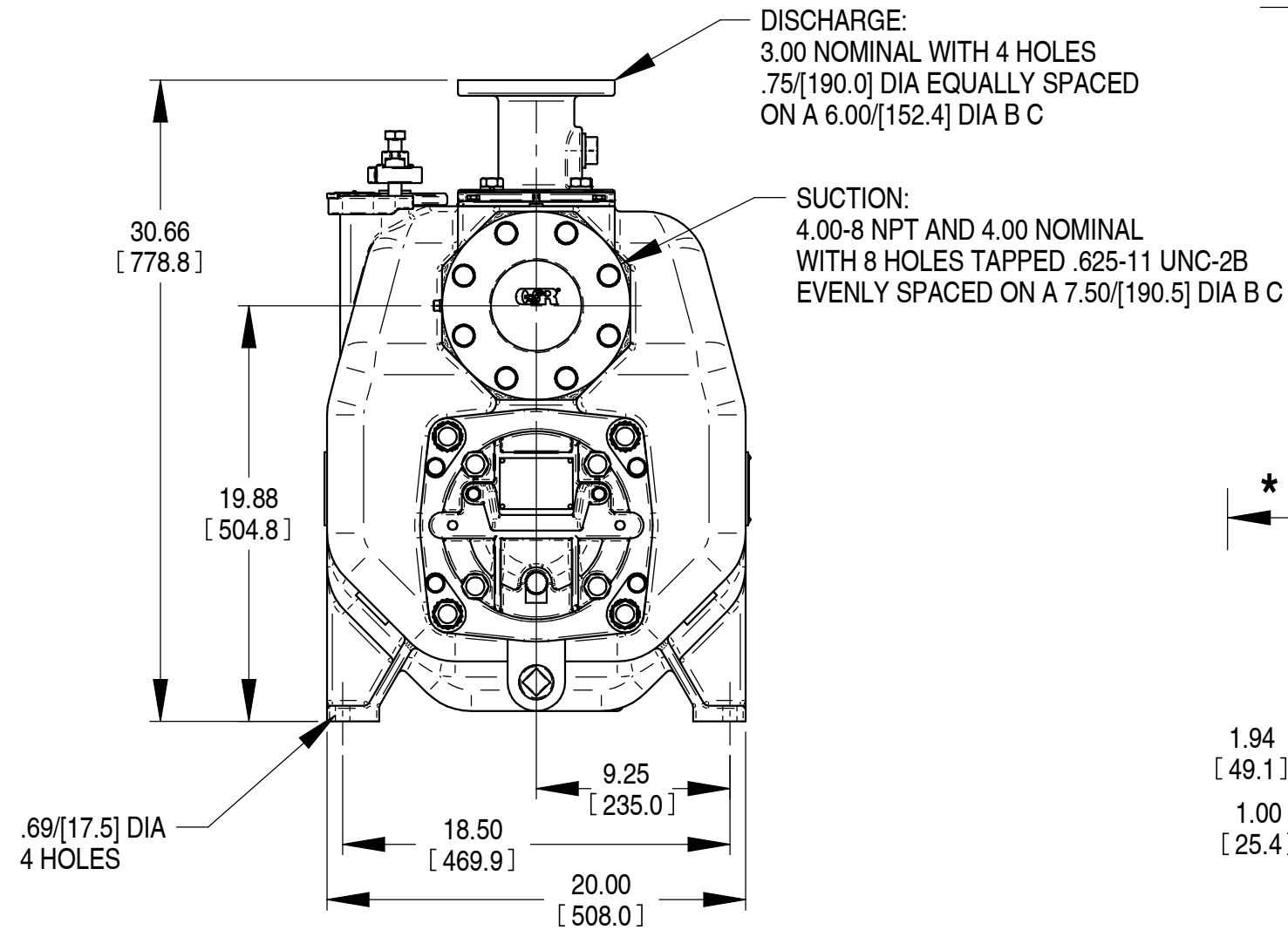

V3A-B
V3B-B
V3CSC-B
V3DSC-B

NOTE:
SHOWN WITH OPTIONAL DISCHARGE SPOOL FLANGE

DIMENSIONS:
INCHES
[MILLIMETERS]

20-008



THE GORMAN-RUPP CO.
MANSFIELD, OHIO ST. THOMAS, ONTARIO

DRAWN BY DFB	SCALE 3/16	MODEL NOTED
DATE 5/23/05	REVISED 7/13/2020	OUTLINE NUMBER 17858